

# TX Series "63"

*Triples Plunger Pump, 3/4" Hollow Shaft*

## FEATURES

- Flanged for direct couple to gasoline engines (SAE J609)
- Set screw for key way
- Oversized bearings
- Longer life low and high pressure seals
- Forged brass manifold with an exclusive lifetime warranty



## SPECIFICATIONS

Pump Model	TX1505G6	TX1506G6	TX1508G6
Maximum Volume	2.0 GPM	2.6 GPM	3.0 GPM
Maximum Discharge Pressure	3000 PSI		
Horsepower	6.2 GBHP	8.0 GBHP	9.2 GBHP
Maximum Pump Speed	3400 RPM		
Maximum Inlet Pressure	125 PSI		
Minimum Inlet Pressure	Flooded		
Plunger Bore	.591 in. / 15 mm		
Plunger Stroke	.197 in. / 5 mm	.256 in. / 6.5 mm	.315 in. / 8 mm
Oil Capacity	14.0 oz.		
Maximum Fluid Temperature	165° F		
Inlet Port Thread	1/2-14 BSPP-F		
Discharge Port Thread	3/8-19 BSPP-F		
Shaft Diameter	3/4 in. / 19 mm		
Weight	18 lbs.		
Dimensions	8.4" x 8.4" x 4.8"		

## DIMENSIONAL DRAWING

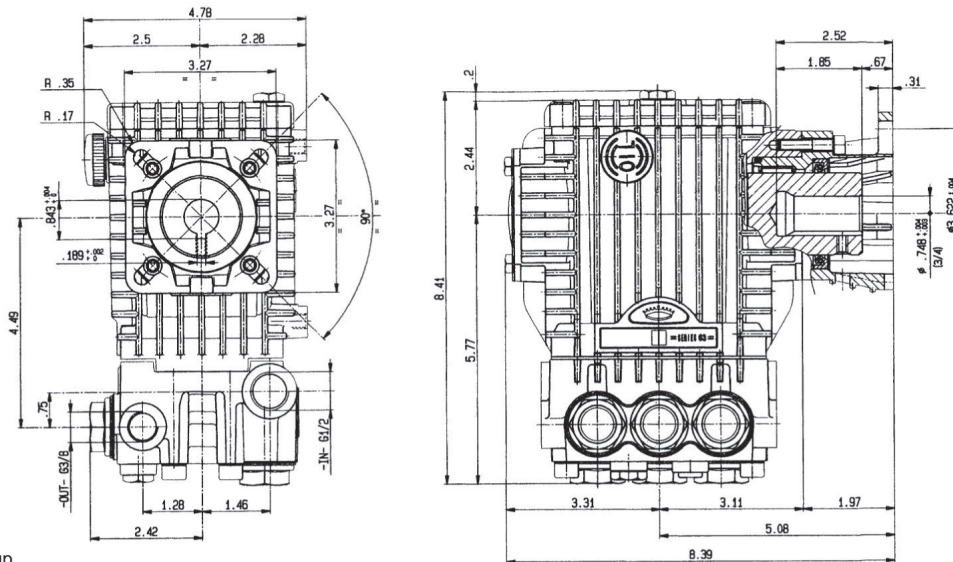

 General Pump is a member of the Interpump Group



# TX Series "63" - 3/4" Hollow

**GENERAL PUMP** *A member of the Interpump Group*

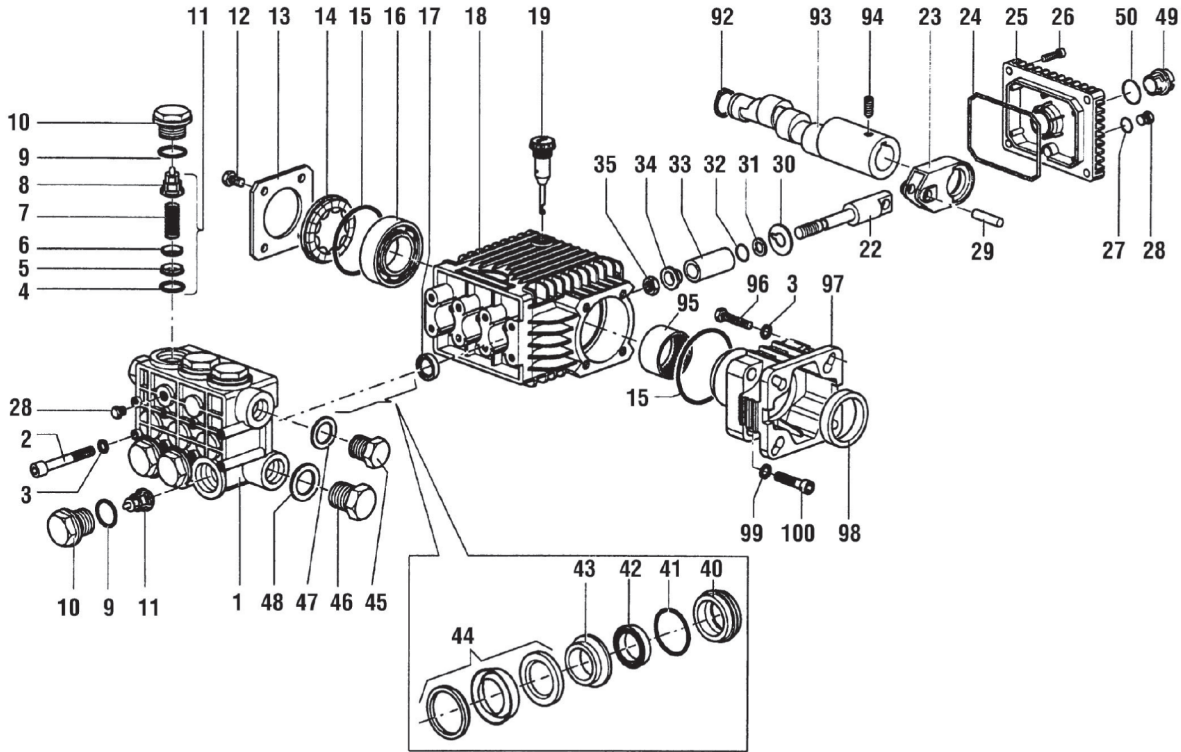

## PARTS LIST

ITEM	PART NO.	DESCRIPTION	KIT NO.	QTY.	ITEM	PART NO.	DESCRIPTION	KIT NO.	QTY.	ITEM	PART NO.	DESCRIPTION	KIT NO.	QTY.
1.	63120041	Manifold, 15 mm		1	22.	63050066	Plunger Guide		3	45.	98210000	Plug, 3/8" G		1
2.	99319200	Screw, M8 x 65		8	23.	63030022	Connecting Rod		3	46.	98217600	Plug, 1/2" G		1
3.	96701400	Lockwasher, M8.4		8	24.	90392000	O-ring, Cover		1	47.	96738000	Washer, M17.5		1
4.	90384100	O-ring	123	6	25.	63160022	Rear Crankcase Cover		1	48.	96751400	Washer, M21.5		1
5.	36200366	Valve Seat	123	6	26.	99183700	Screw, M6 x 14		4	49.	63210051	Oil Level Indicator		1
6.	36200176	Valve Plate	123	6	27.	701013	O-ring		1	50.	90405100	O-ring		1
7.	94737600	Spring	123	6	28.	98204100	Plug, 1/4" G		2	92.	90063500	Retaining Ring		1
8.	36202551	Valve Cage	123	6	29.	97733500	Connecting Rod Pin		3	93.	63026265	Crankshaft, 5 mm		1
9.	90384700	O-ring	124	6	30.	96707500	Flinger Washer		3		63026465	Crankshaft, 6.5 mm		1
10.	98222600	Valve Cap	124	6	31.	660024	Anti-extrusion Ring		3		63026665	Crankshaft, 8 mm		1
11.	36711501	Valve Assembly	123	6	32.	701009	O-ring		3	94.	99179000	Screw, M6 x 6		1
12.	99180700	Screw, M6 x 10		8	33.	52040009	Ceramic Plunger, 15mm		3	95.	91856800	Roller Bearing		1
13.	50150074	Bearing Cover		1	34.	44211570	Bushing		3	96.	99273000	Screw, 5/16" x 3/4"		4
14.	44211801	Oil Level Indicator		1	35.	92221600	Nut, M8		3	97.	10061722	Flange		1
15.	90409700	O-ring		2	40.	63080070	Seal Retn'r, 15mm	162,166	3	98.	90168700	Oil Seal		1
16.	91832900	Ball Bearing		1	41.	90360800	O-ring	166,167	3	99.	96693800	Washer		4
17.	90159500	Oil Seal	159	3	42.	90260800	Seal, LP,15mm	160,166	3	100.	99191200	Screw, M6 x 30		4
18.	63010022	Crankcase		1	43.	63216070	Int. Ring,15mm	164,166	3					
19.	98210300	Oil Dip Stick		1	44.	90261200	Packing Assy,15mm	160,166	3					

## REPAIR KITS

KIT NO.	123	124	159	160	162	164	166
ITEM NO's INCLUDED IN KIT	4, 5, 6, 7, 8 (11)	9, 10	17	42, 44	40	43	40, 41, 42, 43, 44
NUMBER OF ASSEMBLIES IN KIT	6	6	3	3	3	3	1
NUMBER OF CYLINDERS KIT WILL SERVICE	3	3	3	3	3	3	1

## TORQUE SPECS\*

2	14.7	20
10	95.9	130
12	7.3	10
26	7.3	10
28	14.7	20
35	11.0	15
45	29.4	40
46	29.4	40
59	14.7	20
64	7.3	10

\* Decrease torque by 20% if threads are lubricated

**GENERAL PUMP** 1174 Northland Drive • Mendota Heights, MN 55120  
 Phone: 651.686.2199 • Fax: 800.535.1745 • e-mail: sales@gpcompanies.com • www.generalpump.com

300476 Rev. C  
04-11

