

Owner's Manual

- *Installation*
- *Use*
- *Maintenance*



INDEX

1.	INTRODUCTION	Page 3
2.	SYMBOL DESCRIPTIONS	Page 3
3.	SAFETY	Page 3
	3.1 General warnings for safe operation	Page 3
	3.2 High pressure unit safety requirements	Page 3
	3.3 Safety of operation	Page 4
	3.4 General procedures for high pressure lance/gun operation	Page 4
	3.5 Safety of maintenance	Page 4
4.	PUMP IDENTIFICATION	Page 5
5.	TECHNICAL FEATURES	Page 5
6.	DIMENSIONS AND WEIGHT	Page 5
7.	GENERAL INFORMATION ABOUT SPECIFIC PUMP USE	Page 6
	7.1 Water temperature	Page 6
	7.2 Maximum flow and pressure ratings	Page 6
	7.3 Lowest operating RPM	Page 6
8.	CONNECTION AND PLUGS	Page 6
9.	PUMP INSTALLATION	Page 7
	9.1 Positioning	Page 7
	9.2 Direction of rotation	Page 7
	9.3 Water connections	Page 7
	9.4 Suction line	Page 7
	9.5 Filtration	Page 8
	9.6 Delivery time	Page 8
10.	START UP AND RUNNING PROCEDURES	Page 8
	10.1 Before start up	Page 8
	10.2 Starting up	Page 8
	10.3 Water cooling system	Page 9
11.	MAINTENANCE INSTRUCTIONS	Page 9
	11.1 Crank mechanism maintenance	Page 9
	11.2 Fluid end maintenance	Page 10
	11.3 Pumping unit maintenance	Page 11
12.	SCREW CALIBRATION	Page 14
13.	MAINTENANCE TOOLS	Page 14
14.	PUMP STOPPED FOR LONG TIME	Page 14
15.	PRECAUTIONS AGAINST FREEZING	Page 14
16.	EXPLODED VIEWS AND PARTS	Page 15
17.	TROUBLE SHOOTING	Page 17

1. INTRODUCTION

SH high pressure water plunger pumps have been designed for long life industrial duties and provided they are correctly installed and maintained will give long trouble-free operation. Read and understand this manual before using your pump; it contains the necessary information for the correct installation, use and maintenance as well as some practical suggestion for trouble shooting.

Upon receipt of your pump, inspect for overall good condition and that no items are missing. Any missing item or damage should be reported before installing and starting the pump.

2. SYMBOL DESCRIPTIONS

**Warning**

Potential Danger

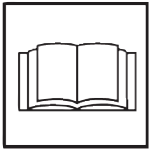

Read carefully and understand the manual before operating the pump

**Danger**

High Voltage

**Danger**

Wear protective mask

**Danger**

Wear goggles

**Danger**

Wear protective gloves

**Danger**

Wear protective boots

3. SAFETY

3.1 General warnings for safe operation

The misuse of a high pressure water unit and the non-observance of the pump installation and maintenance instructions may cause serious damages and/or injuries to people or properties or both.

Any Manufacturer/Operator requested to assemble/use a high pressure water unit should be competent to do so, should have the necessary knowledge on every high pressure component installed in the unit and on the precautions to be taken in order to guarantee the largest safety margins during operation. No precaution, so far as is reasonably practical, should be left out in the interest of safety, both from the Manufacturer and the Operator.

3.2 High pressure unit safety requirements

1. A safety valve should be installed in any delivery line and should be sized to discharge or by-pass the entire pump flow rate
2. High pressure unit components, with particular regard for those units working outside, should be adequately protected against rain, frost and heat.
3. Electric components and wiring should be provided with an adequate degree of protection, able to protect them against spray coming from any direction. They should also be suitable for working in a wet environment.
4. High pressure hoses and any other accessory under pressure should be sized in accordance with the maximum unit working pressure and must always work within the safety margins indicated by the nose/ accessory Manufacturer.
5. High pressure hose ends should be fastened to a steady object in order to prevent them from dangerous sweeping around, should they burst or come off their end fittings.
6. Proper safety guards should be provided to adequately cover transmission joints, pulleys, belts or auxiliary drives.



3.3 Safety of operation

The access into the area when a high pressure unit is working should be strictly prohibited to unauthorized personnel. The area should be suitably enclosed and its perimeter, so far as is reasonably practical, cordoned off and proper warning notices displayed in prominent positions.

Personnel authorized to enter that area should have been previously trained to do so and informed of the risks arising from failures, misuse and any foreseeable circumstance which may occur during operation. Before starting the pump unit and bringing it up to pressure the Operator is requested to carry out the following checks:

1. Make sure that a correct water supply to the pump is provided.
2. Make sure that water inlet filters are properly clean.
3. Electrical components and wiring, with special emphasis on connections, junction boxes, switches and supply cables should be free from external damage (i.e. exposed and broken wires) and adequately protected against water.
4. High pressure hose should not show apparent external wear and the fittings at both ends should be free from signs of erosion or corrosion.
5. Make sure that all fluids (lubricating oil for pump and engine, cooling water, hydraulic fluids) are at proper levels and in good condition.
6. Make sure the safety guards are in good condition.

The work should stop immediately and the pressure must be released in the event that leakage becomes apparent or if any person becomes aware of a change in condition or any hazard existing or being introduced. Any failure must be promptly reported and then checked personnel.



3.4 General procedures for high pressure gun/lance operation

1. The Operator should take reasonable care for the safety of himself and of other persons who may be affected by his acts or omission at work. His actions should always be governed by his good sense and responsibility.
2. The Operator should wear suitable waterproof protective clothing, having regard to the type of work being undertaken. The clothing set should include adequate hand protection, suitable boots able to ensure proper grip on wet floors, helmet provided with full face shield, waterproof garment providing full cover to the Operator, including his arms.
As most water jets produce noise levels in excess of

90 dB(A) suitable ear protection is advised.

NOTE: it must be emphasized that whereas protective clothing provides adequate protection against spray and flying particles, it does not constitute complete protection against the direct impact of the water jet. Additional protections in the form of suitable metal shields or barriers may be necessary for certain jetting operation.

3. In most jetting operations it is an accepted practice to employ a team of Operators consisting of two members at least, in order to provide mutual assistance in case of need and to rotate their duties in case of long and heavy work. While the first Operator holds the gun, the second Operator attends the pump unit, keeping close watch on the first Operator for signs of difficulty or fatigue, and watching the surrounding area for intrusion by other persons or unsafe situations. If required, he will shut off the pressure unit until it is safe to continue.
4. The area in which the work is to proceed should be clear of loose items and debris to prevent tripping and slipping hazards.
5. The water jet should be directed only and always against the workpiece even during preliminary operating tests prior to starting work.
6. Where applicable, proper side shields should be suitable placed to safeguard personnel and equipment against contact with grit or particles removed by the water jet.
7. On no account must the Operator be distracted during operation until the jet has been stopped. Personnel having reason to enter the water jetting area should wait until the jet is stopped and his presence known.
8. Each team member must always be aware of the actions and intentions of other team members in order to prevent any dangerous misunderstanding occurring during jetting operation.
9. The pump unit should not be started and brought up to pressure unless each team member is in his designated position, the nozzle directed to the workpiece and the lance or gun securely held.

3.5 Safety of maintenance

Apart from the working pressure regulation no attempt should be made to adjust any nut, hose, fitting, etc., while that part of the system is under pressure. The pump should be stopped and any pressure in the line released prior to making any adjustments.

1. The high pressure water unit should be maintained in accordance with the Manufacturer's instructions.
2. The unit should be maintained only by competent personnel
3. Service and maintenance should be carried out with proper tools in order to prevent any damage on high pressure connections and fittings.
4. Use of other than original spare parts is strictly forbidden.

7. GENERAL INFORMATION ABOUT PUMP USE



The SH pump has been designed to pump fresh filtered water at room temperature.

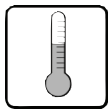

7.1 Water temperature

The max water temperature is 30°C (86°F)

7.2 Max flow and pressure ratings

The performance data indicated in the catalog and on the rating plate refer to the maximum performance of the pump. The use of the pump below the rated performances does not allow the drop in power absorbed to be balanced by altering the pressure or volume of the pump above its maximum value.

7.3 Lowest operating RPM

The lowest operating speed **of the crankshaft** for all SH pumps (all versions) is 350 RPM.

8. CONNECTIONS AND PLUGS

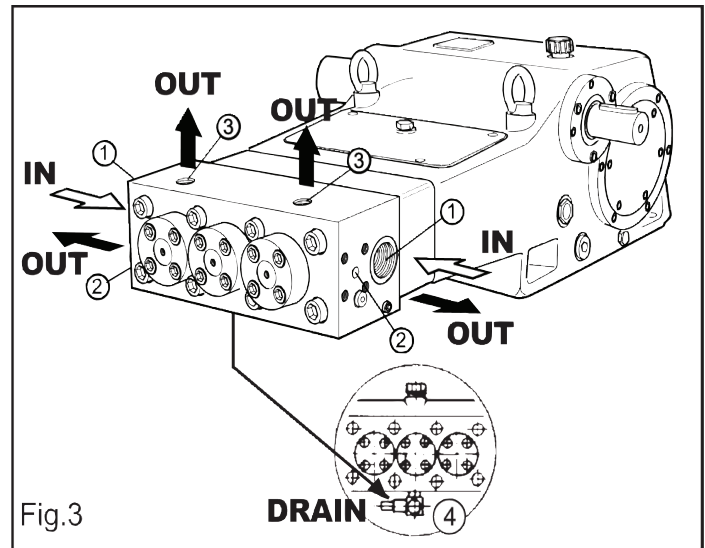

Fig.3

SH pumps are provided with (Fig. 3):

- 1 - 2 inlet ports IN G 1-1/2"
Suction line connection to either inlet port is acceptable, the port not being used should be sealed with the correct plug.
- 2 - 2 outlet ports OUT Ø 14mm"
- 3 - 2 outlet ports OUT Ø G 1/2" (designed for pressure gauge and safety valve only)
- 4 - 1 hole DRAIN provided with quick coupling for connection with Rilsan air hose Ø 10 mm; it collects the water drainage from the cooling system and should be connected back to the suction line BEFORE the feed pump.

The SH pump is supplied with 4 conical seals (Fig 4) made of stainless steel and designed to provide total sealing of the outlet connections. They must be used in either the outlet ports of the head or in the outlet ports of the optional outlet mounting flanges. **The conical seals should be replaced at any disassembling and not re-used.**

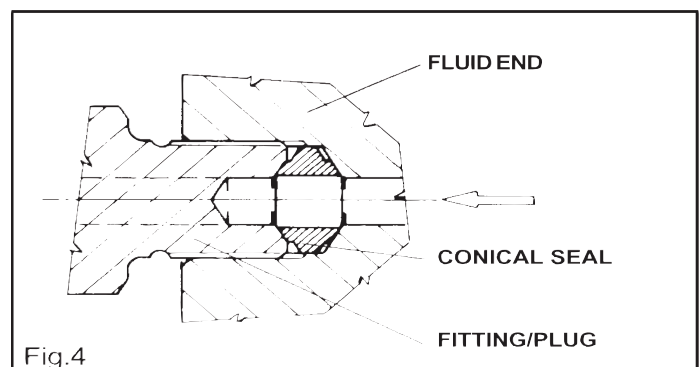

Fig.4

9. PUMP INSTALLATION

9.1 Positioning

The pump should be installed flat on a rigid base by means of the four Ø 19mm feet. The base should be rigid enough to avoid any misalignment or flexing of the pump/transmission coupling axis due to the torque involved during operation.

9.2 Direction of rotation

Fig. 5 shows the correct direction of rotation looking at the pump from the fluid end side. Two arrows stamped on the crankcase nearby the crankshaft provide the information as well.

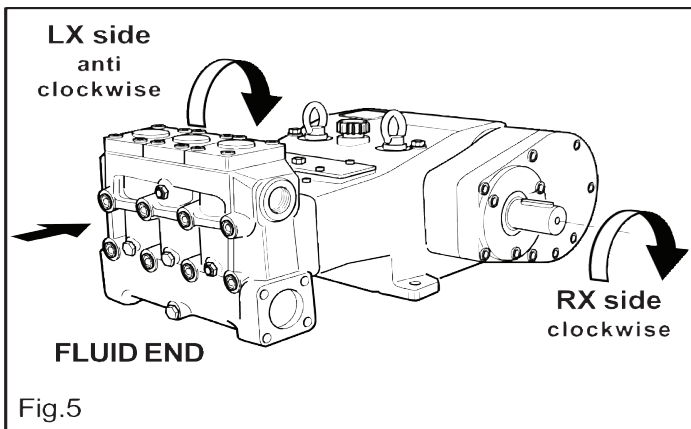

9.3 Water connections

In order to isolate the high pressure equipment from the pump vibrations it is suggested, where applicable, to use flexible hoses for both suction and delivery lines at least for the first length.

9.4 Suction Line

Sh pumps require an inlet pressure at the suction port of at least 73 PSI up to 100 PSI. The feeding pump should be of a centrifugal type, supply at least twice the rated SH pump flow rate at the above required pressures in any working condition at any pump speed. The feed pump should be operated independently from the plunger pump. The SH pump should be started only when the inlet pressure is at least 73 PSI. A pressure switch to control the correct inlet pressure should always be installed in the suction line after the filters.

9.4 Suction line

For the correct pump operation make sure that the suction line meets with the following requirements:

1. Internal diameter should be at least 1.5", in any point, possibly larger depending on the drop in pressure due to the length and shape of the line.
2. Should be as straight as possible minimizing changes in size and direction and positioned in such a way to allow air pockets and bubbles to escape.
3. Should be perfectly airtight.
4. Should be completely free from 90° elbows, diameter reductions, counter slopes, "T" connections and should not be connected to other pipelines.
5. Should be positioned in such a way to prevent the pipe emptying after the pump stops.
6. Do not use high pressure flexible hoses for the suction line.
7. Do not use high pressure hydraulic fittings like 90° elbows, high pressure adapters, high pressure 3 or 4 way nipples and so on.
8. Do not install any kind of detergent injector along the suction line.
9. Do not install standing valves, check valves or other kind of one-way valves.
10. Make sure that the feed tank capacity and the water minimum level do not give rise to turbulence at the tank outlet port, which, in turn, might create cavitation at the pump.
11. Do not connect the by-pass line from the valve directly to the pump suction line.
12. The water flow from the valve should be directed back in the tank. Make sure that the by-pass and tank feeding flows do not give rise to turbulence at the tank outlet port, which, in turn, might create cavitation at the pump. Proper baffle plates should be provided inside the tank.
13. Before connecting the suction line to the pump inlet port make sure the pipe is perfectly clean inside.

9.5 Filtration

SH pumps require 10 to 20 microns water filtration degree. For a correct filtration system three individual filter units should be provided and positioned as shown in Fig. 6.

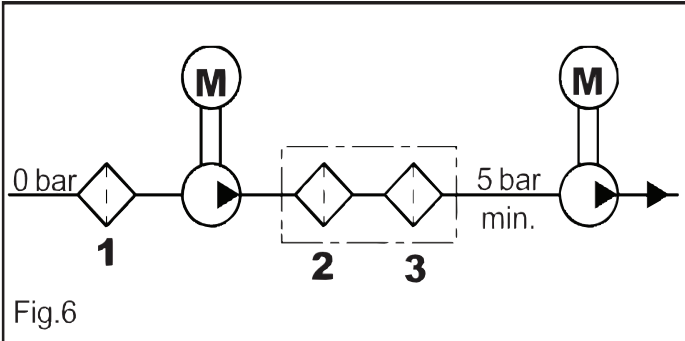

The filters should be installed as close as possible to the pump, allow easy inspection and have the following specifications:

- a. Capacity of each filter should be at least three times the rated pump flow rate.
- b. Filter port diameters should not be smaller than the pump inlet ports.
- c. Filtration degree of each filter should be as follows:
 - Filter 1: 250 microns
 - Filter 2: 70 - 100 microns
 - Filter 3: 10 - 20 microns

IMPORTANT NOTE: in order to properly safeguard the pump it is very important to plan cleaning of the filter **with a frequency depending on the water quality, filtration degree and number of hours of each application.**

9.6 Delivery line

For a correct delivery line comply with the following instructions:

1. The first length of delivery hose should be flexible in order to isolate the pump vibrations from the rest of the system.
2. Use only high pressure hoses and fittings able to guarantee the largest possible safety margins in any working conditions.
3. A suitable relief valve should be installed in the delivery line.
4. Use glycerine filled pressure gauges, as the most suitable for pulsating loads.
5. When designing the delivery line, take into proper account the unavoidable drop in pressure, due to its length and size.

10. START UP AND RUNNING PROCEDURES

10.1 Before start up

Before start up make sure that the following conditions have been complied with:

1. Suction line should be connected: **the pump must never run dry.**
2. Suction line must be perfectly air-tight.
3. Any ON-OFF valve in between the pump and water source should be open and make sure the water gets into the pump freely.
4. Set the pressure line in dump mode in order to let the air in the pump get out easily thus facilitating the pump priming.
5. Make sure all suction/delivery line connections are fully tightened.
6. Joint alignment, belt tightening and PTO shaft inclination tolerances should remain within the values indicated by the transmission Manufacturer.
7. Make sure the oil level is correct.

Note: in case the pump has not run for a long period of time check the suction and delivery valves for scaling (see paragraph 11.2).

10.2 Starting up

1. Pump and motor/engine should start offload, set the regulating valve to zero or set the pressure line in dump mode by means of proper dumping devices.
2. Make sure the pump starts only when the correct inlet pressure is provided.
3. When starting the pump up for the first time or after every wiring re-connection check for the proper direction of rotation.
4. Check that the rotating speed does not exceed the rated value.
5. Before putting the pump under pressure let it run for some time until the oil flows freely.
6. Before stopping the pump release the pressure from the system by operating the dump device or by releasing the regulating valve and reduce RPM to a minimum (diesel applications).

10.3 Water cooling system

During operation the cooling water is drained out of the pump through the port (4, Fig. 7) located underneath the pump head. The cooling water line should be connected to the inlet line **BEFORE** the feed pump as shown below.

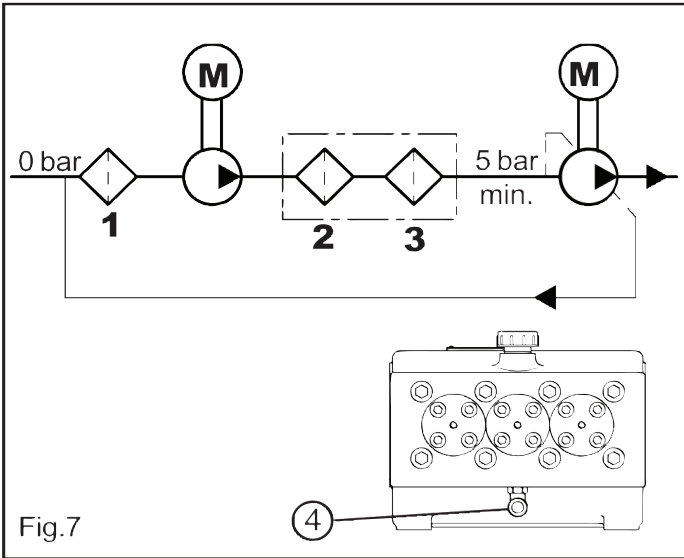

Fig.7

11. MAINTENANCE INSTRUCTIONS



11.1 Crank mechanism maintenance.

Check oil level through the oil level indicator (1, Fig. 8) at least on a weekly basis.

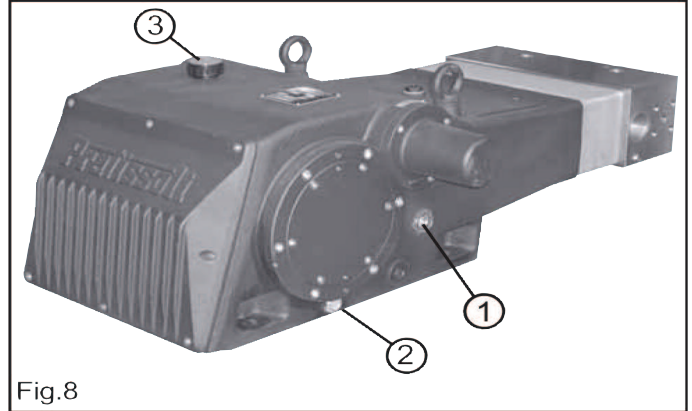

Fig.8

If necessary, top up from the oil plug 3, Fig. 8.

Check the oil when cold and change the oil when still hot (pump still at working temperature.).

In order to drain the oil from the pump remove the magnetic plug 2, Fig. 8.

At every oil change clean the magnetic plug 2, Fig. 8 and check the lower cover of Fig. 7 for grease sediments or deposits.

OIL CHANGES	Hours	Qty.	Oil Type
First Change	50	3.1 quarts	ISO 220
Subsequent Changes	500		

Oil should be changed at least once a year.

Recommended oils:

BRAND	TYPE
AGIP	ACER 220
ARAL	MOTANOL HP 220
AVIA	AVILUB RSL 220
BP	ENERGOL HL 220
CASTROL	ALPHA ZN 220
ESSO	NUTO 220
FINA	SOLNA 220
IP	HYDRUS 220
MOBIL	DTE OIL BB
SHELL	TELLUS C 220
TEXACO	REGOL OIL 220
TOTAL	CORTIS 220

11.2 Fluid end maintenance

The fluid end does not require periodical maintenance. Service operations are limited to valve inspection and/or replacement, when necessary.

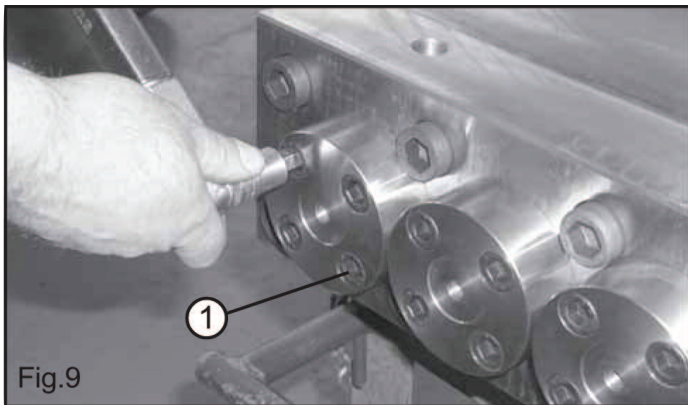

In order to have access to the delivery valves loosen the 12 valve cover screws (1, Fig. 9) and remove the covers.

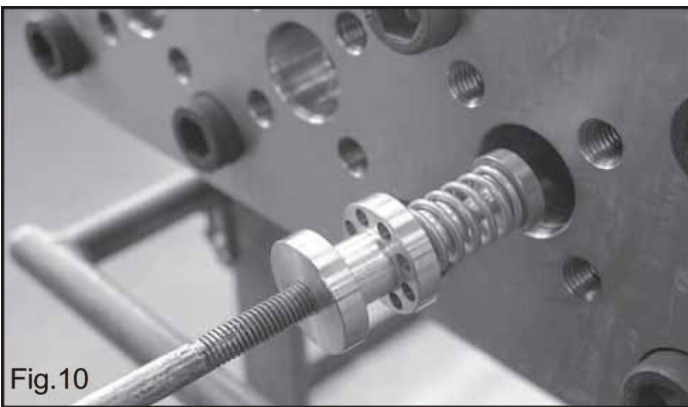

Once removed take out the delivery valve guide with the spring and valve poppet. AN M10 threaded bolt to be used as a simple extractor would help the operation (see Fig. 10).

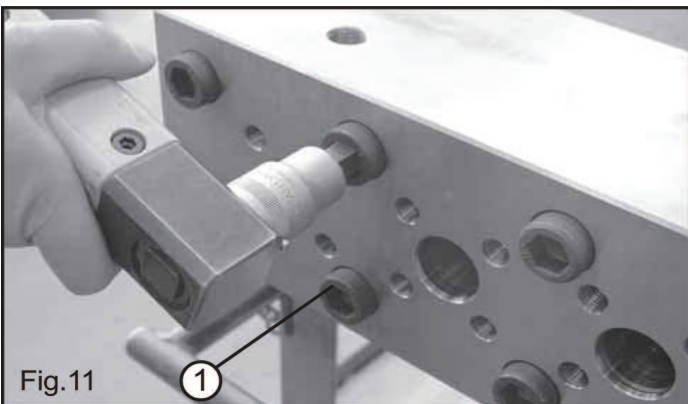

Loosen and remove the 8 head screws (1, Fig. 11).

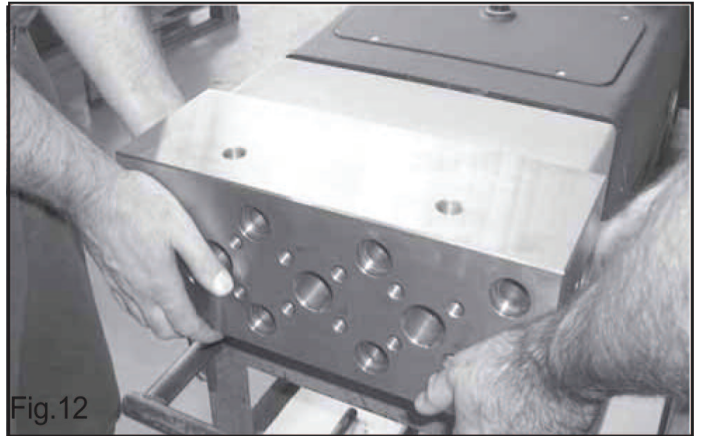

Remove the pump head. (Fig. 12)

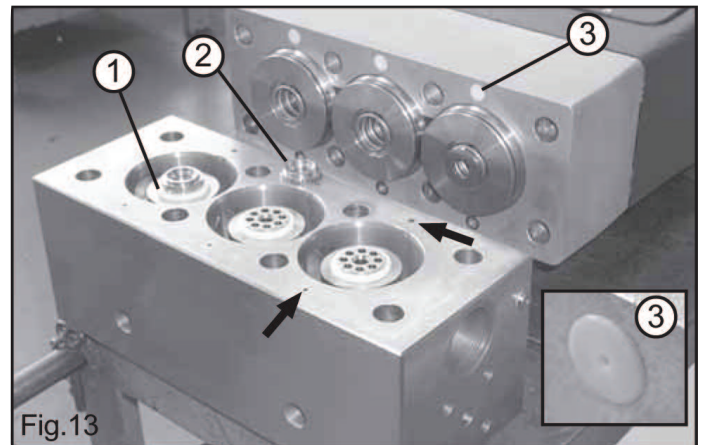

When removing the head from the pump pay attention to the valve seats (1, Fig 13) and the suction valve poppets (2, Fig. 13) which may fall off the head. Check the cooling system orifices of the head (see arrows) and the relevant white tips (3, Fig. 3) for deposits or sediments that may prevent cooling water from flowing through.



Remove the valve seats (1, Fig 14) from the head, check them for wear and replace if necessary.

BEFORE REPOSITIONING THE VALVE UNITS BACK IN PLACE CLEAN AND PERFECTLY DRY ALL VALVE HOUSINGS INSIDE THE HEAD.

VALVE RINGS (2, FIG. 14) AND ALL O-RINGS SHOULD BE REPLACED AT EVERY INSPECTION.



Reassemble valves and head back in place by following the disassembling steps in the opposite sequence and use a torque wrench at the following settings for valve cover screws and head screws:

- Valve cover screw: 144.6 ft. lbs.
- Head screws: 397.8 ft. lbs.

NOTE:

In order to facilitate reassembling operation use our tool 1, Fig. 15 (p/n F200030140 for SH20-24, p/n F200030130 for SH26-30) or equivalent, able to hold the valve seat and valve poppet in place when mounting the head on the pump (see arrow Fig. 16).

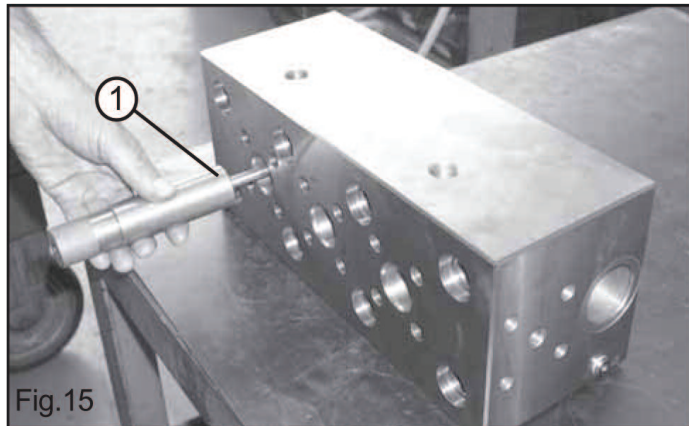

Fig.15

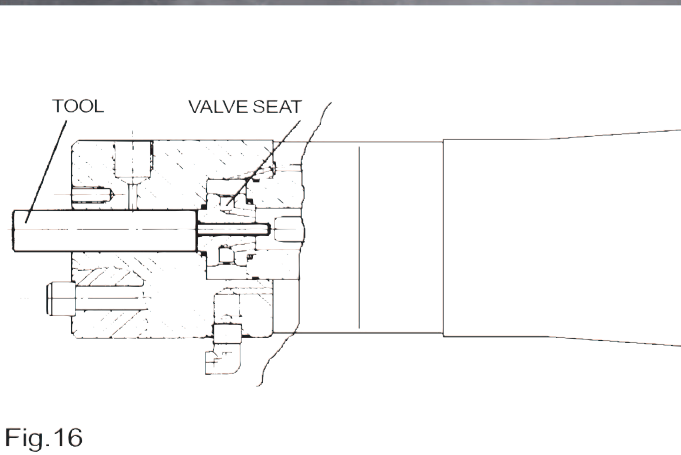
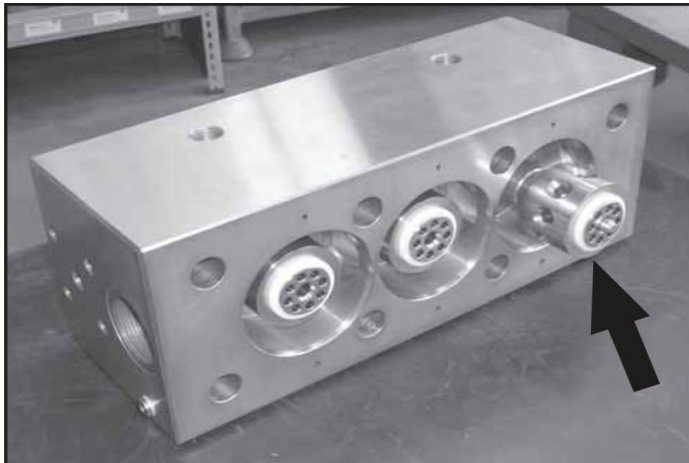

Fig.16

11.3 Pumping unit maintenance.

The only maintenance operation required for the pumping unit is the visual check of the amount of water drained out by the cooling system through the hole provided underneath the head (Fig. 7, page 9). It clearly shows the pressure packing state of wear. Pressure packings should be replaced when vibration and/or drop in the operating pressure start to occur during operation.

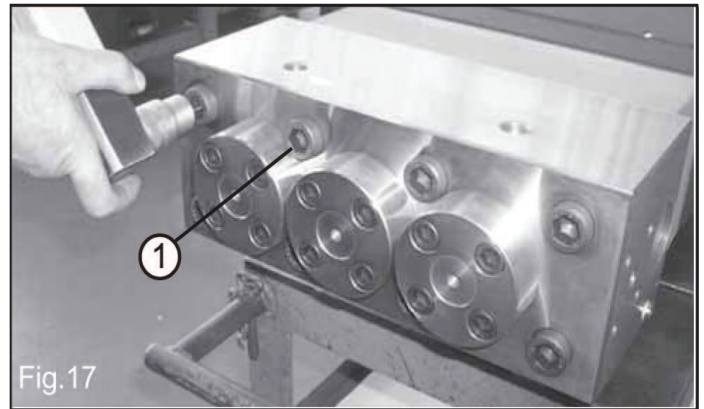

Fig.17

Remove the eight head screws (1, Fig. 17).

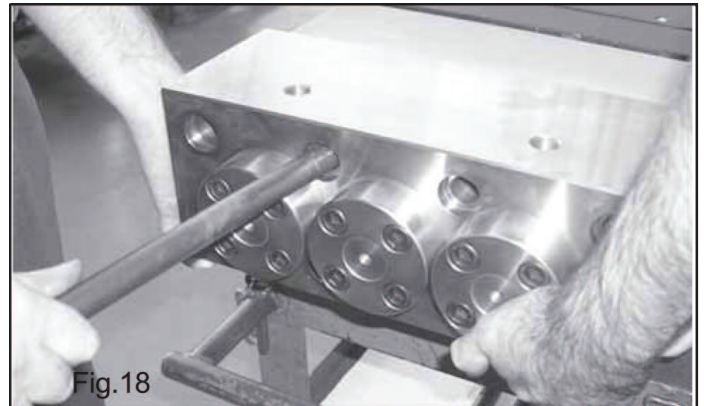

Fig.18

Remove the pump head (see chapter 11.2).

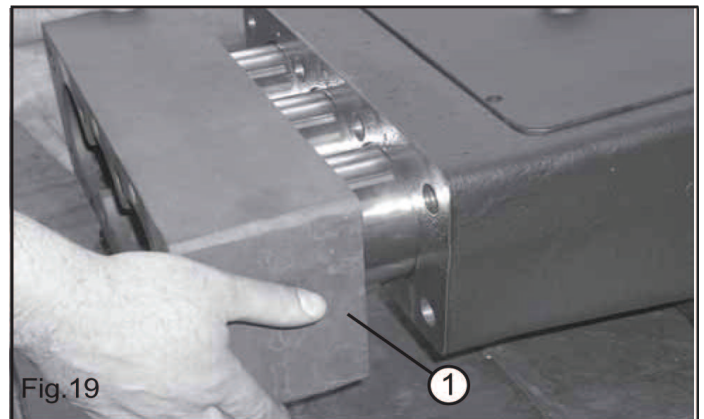
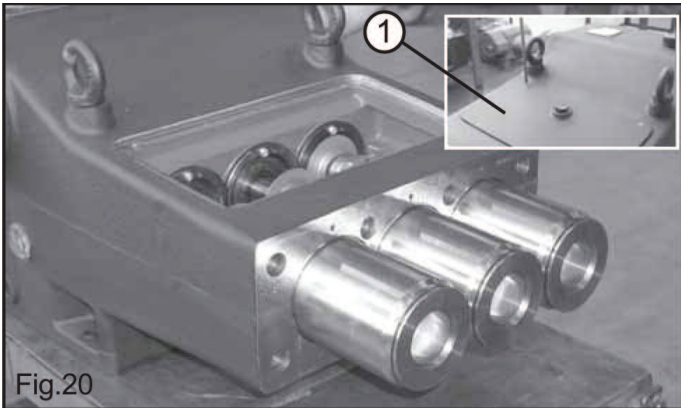
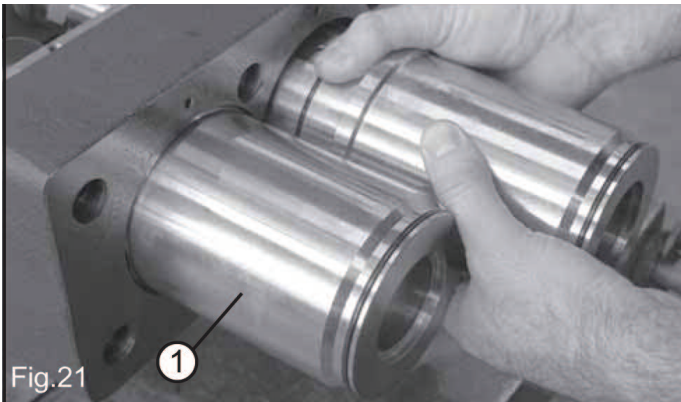

Fig.19

Take out the collector (1, Fig. 19).



Remove the upper cover (1, Fig. 20).



Once head and collector are removed the cylinders (1, Fig.21) are free to be taken out of the pump body. Tapping the cylinders all around with a plastic hammer helps to loosen them from possible scaling or deposit accumulated during operation.



Once the cylinders are removed, loosen the plungers and check them for wear (Fig 22). Replace if necessary.



Remove the seeger (1, Fig. 23).

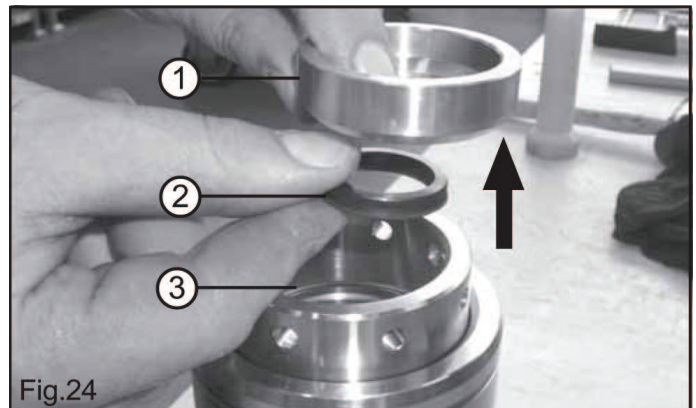

Remove the rear support 1, the rear seal 2 and the o-ring (3, Fig. 24).

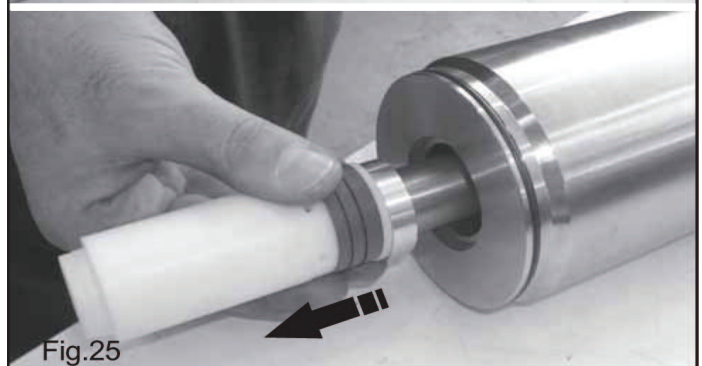

Insert a pin of adequate dimensions and smartly tap until the complete pressure packing set is out (Fig. 25). **Replace pressure packing set at every inspection.**

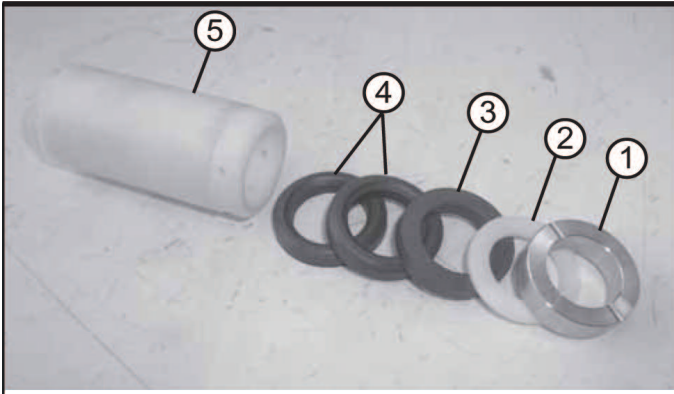

Fit each new component of the pressure packing set in the cylinder making sure of the correct order as shown in Fig 26:

1. Packing bushing
2. Packing ring
3. Back packing
4. Pressure Packings
5. Pressure packing retaining bushing



Each pressure packing set component should fit tight in the cylinders. A pin of adequate dimension (1, Fig. 27) helps in guiding each component straight and aligned all the way down the cylinder.

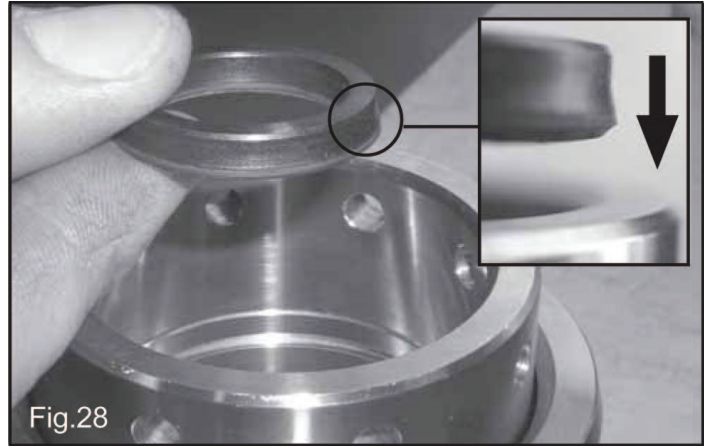

The new rear seal should be mounted with the larger diameter side first in, as shown in Fig. 28.



Reassemble the pump by following the disassembling steps in the opposite sequence and use a torque wrench for the screws listed below:

- Plunger screws: 72.3 ft. lbs.
- Head screws: 397.8 ft. lbs.
- Valve cover screws: 144.6 ft. lbs.

12. SCREW CALIBRATION



Screw calibration is to be carried out by means of a torque wrench only:

DESCRIPTION	Ft. Lbs.	N-m	Kgm.
Valve cover screws	144.6	196.1	20
Head Bolts	397.8	539.3	55
Plunger bolts	72.3	98	10
Connecting Rod Screws	54.2	73.5	7.5

13. MAINTENANCE TOOLS



The following tools are designed to facilitate mounting and dismounting operations of some pump components:

for disassembling:

-cylinder extractor F200000190

for assembling:

-head/valve seat tool SH20-24 F200030140

-head/valve seat tool SH26-30 F200030130

14. PUMP STOPPED FOR LONG TIME



Before starting the pump for the very first time after a long period from the date of shipment check for the correct oil level, check the valves as indicated in chapter 11 and then comply with the starting procedures indicated in chapter 10. When a long inactivity is scheduled drain the entire suction and delivery line and then run the pump dry **only for a few seconds** in order to drain out the water collected inside the fluid end.

15. PRECAUTIONS AGAINST FREEZING



In the risk of freezing the following precautions should be taken:

- After use drain the entire suction and delivery lines (filter included) by means of discharging devices, provided and positioned specifically for this purpose along the lowest point of the lines.
- Run the pump only for a few seconds in order to drain the water collected inside the fluid end.

Or when applicable

- Add a recommended amount of anti-freeze into the water tank and run the pump until the anti-freeze works all through the system.



If a pump is frozen or appears frozen ON NO ACCOUNT SHOULD THE PUMP BE OPERATED until the entire system has been thawed out.

16. EXPLODED VIEW AND PARTS LIST

SH

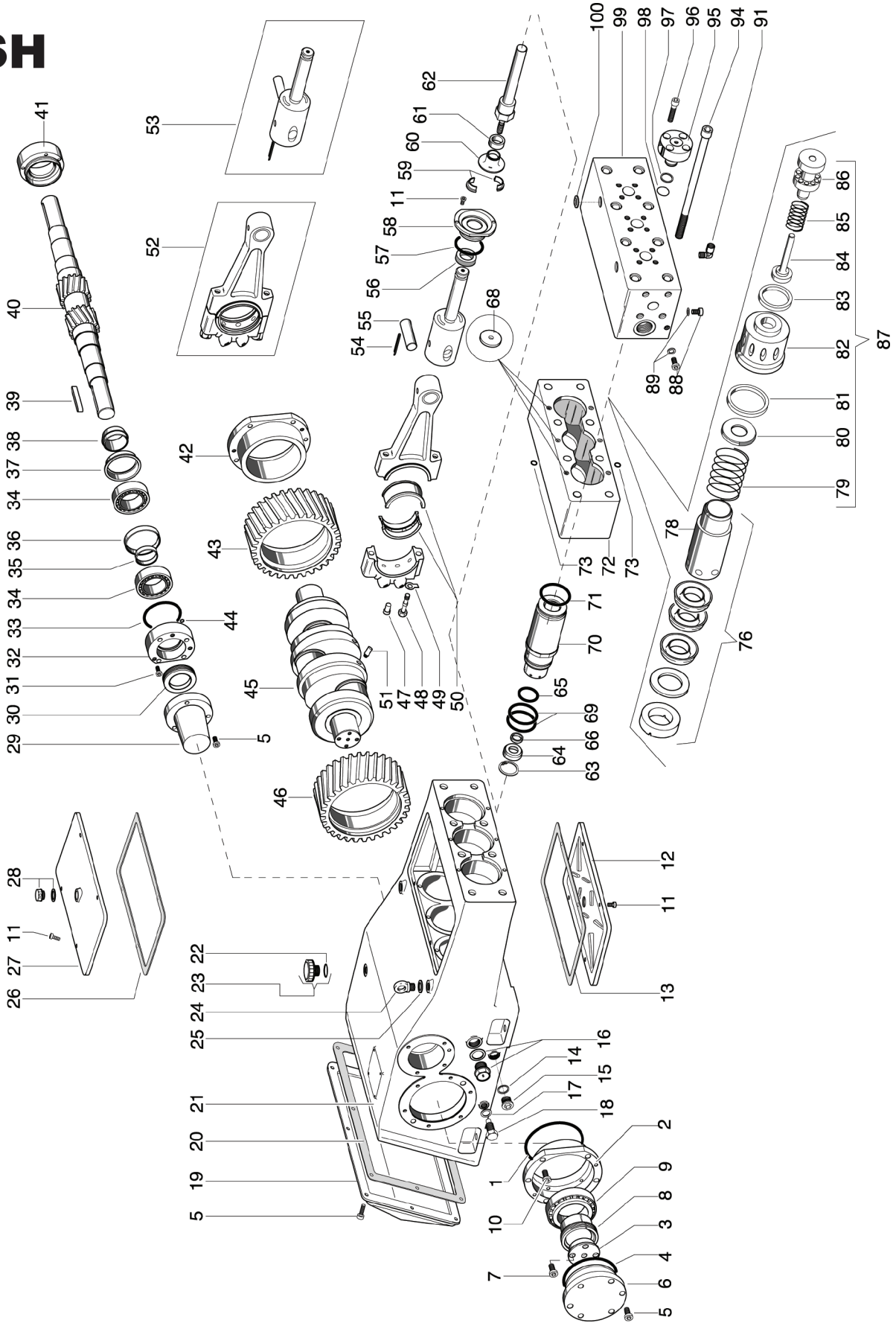

Item	Part #	Description	QTY.
1	F881010133	O-ring Ø 183.82 x 2.62	2
2	F010100070	Left bearing support	1
3	F030000010	Bearing bushing retainer flange	2
4	F881010132	O-ring Ø 152.07 x 2.62	2
5	F871121152	Screw M8 x 20	23
6	F063400280	Bearing cover	2
7	F871131102	Screw M12 x 25	8
8	F030000020	Bearing bushing	2
9	F8111101017	Bearing	2
10	F871125154	Screw M10 x 30	12
11	F871115152	Screw M6 x 14	14
12	F040400050	Lower cover	1
13	F080600030	Lower cover gasket	1
14	F872043008	Aluminum washer Ø 1"	2
15	F821203006	Plug G 1"	2
16	F801053012	Oil level indicator G 1"	2
17	F872043002	Aluminum washer G 1/2"	2
18	F801057002	Magnetic plug G 1/2"	2
19	F063400240	Back cover	1
20	F080600010	Back cover gasket	1
21	F060100160	Crankcase	1
22	F881010116	O-ring Ø 29.82 x 2.62	1
23	F801054027	Oil filling plug G 1"	1
24	F872026003	Eye bolt M16	2
25	F030000030	Eye bolt spacer	2
26	F080600020	Upper cover gasket	2-4
27	F040400030	Upper cover	1
28	F801056002	Venting plug G 1/2"	1
29	F040400070	Crankshaft end cap	1
30	F881080026	Oil seal Ø 55 x 75 x 10	2
31	F871121105	Screw M8 x 30	8
32	F063400300	Left bearing cover	1
33	F881010130	O-ring Ø 94.92 x 2.62	2
34	F811101019	Bearing	4
35	F031000020	Internal bearing spacer	2
36	F031000010	External bearing spacer	2
37	F061000000	Lubricating bushing	2
38	F031400000	Lubricating cone	2
39	F872097013	Pinion key	1
40	F052000020	Pinion 1500 RPM	1
	F052000050	Pinion 1750 RPM	1
41	F063400310	Right bearing cover	1
42	F010100080	Right bearing support	1
43	F052000000	Gear 1500 RPM	1
	F052000030	Gear 1750 RPM	1
44	F881010003	O-ring Ø 8.73 x 1.78	2
45	F050000060	Crankshaft	1
46	F052000010	Gear 1500 RPM (Z59 right toothing)	1
	F052000040	Gear 1750 RPM (Z61 right toothing)	1
47	F034000000	Connecting rod pin	3
48	F035000070	Connecting rod screw	6
49	F872067006	Locking washer Ø 12	6
50	F023300000	Brass bearing	3
51	F002000000	Crankshaft pin	2
52	F250000030	Connecting rod assembly	3
53	F250001110	Piston assembly	3
54	F872142015	Retainer pin Ø 5 x 36	3
55	F071000050	Wrist pin Ø 35	3
56	F881081001	Oil seal Ø 35 x 47 x 8.5 Spec.	3
57	F881010128	O-ring Ø 72.69 x 2.62	3
58	F063400420	Oil seal cover	3
59	F030000070	Wiper bushing	3
60	F041200010	Wiper	3
61	F031200440	Wiper spacer	3
62	F124200220	Plunger SH20	3
	F124200230	Plunger SH22	3
	F124200240	Plunger SH24	3
	F124200250	Plunger SH26	3

Item	Part #	Description	QTY.
62	F124200260	Plunger SH28	3
	F124200270	Plunger SH30	3
63	F872071530	Seeger Ø 52 SH20-22-24	3
	F872071533	Seeger Ø 58 SH26-28-30	3
64	F031300170	Scraper ring SH20	3
	F031300180	Scraper ring SH22	3
	F031300220	Scraper ring SH24	3
	F031300210	Scraper ring SH26	3
	F031300200	Scraper ring SH28	3
	F031300190	Scraper ring SH30	3
65	F881010122	O-ring Ø 47.30 x 2.62 SH20-22-24	3
	F881010140	O-ring Ø 52.07 x 2.62 SH26-28-30	3
66	F881030009	Seal ring SH20	3
	F881030010	Seal ring SH22	3
	F881030040	Seal ring SH24	3
	F881030041	Seal ring SH26	3
	F881030012	Seal ring SH28	3
	F881030013	Seal ring SH30	3
68	F083500020	Cooling system tip	3
69	F881010142	O-ring Ø 75.87 x 2.62	6
70	F162200050	Cylinder SH20	3
	F162200060	Cylinder SH22	3
	F162200070	Cylinder SH24	3
	F162200080	Cylinder SH26	3
	F162200090	Cylinder SH28	3
	F162200010	Cylinder SH30	3
71	F881010143	O-ring Ø 82.22 x 2.62	3
72	F064400020	Collector	1
73	F881010100	O-ring Ø 9.19 x 2.62	9
76	F205000050	Pressure packing kit SH20	3
	F205000060	Pressure packing kit SH22	3
	F205000070	Pressure packing kit SH24	3
	F205000080	Pressure packing kit SH26	3
	F205000090	Pressure packing kit SH28	3
	F205000100	Pressure packing kit SH30	3
78	F031500190	Pressure packing retaining bushing SH20	3
	F031500200	Pressure packing retaining bushing SH22	3
	F031500210	Pressure packing retaining bushing SH24	3
	F031500220	Pressure packing retaining bushing SH26	3
	F031500230	Pressure packing retaining bushing SH28	3
	F031500240	Pressure packing retaining bushing SH30	3
79	F090200180	Suction valve spring SH20-22-24	3
	F090200200	Suction valve spring SH26-28-30	3
80	F082200230	Suction valve poppet SH20-22-24	3
	F082200270	Suction valve poppet SH26-28-30	3
81	F080500170	Ring (Suction side) SH20-22-24	3
	F080500200	Ring (suction side) SH26-28-30	3
82	F081200570	Valve seat SH20-22-24	3
	F081200650	Valve seat SH26-28-30	3
83	F080500160	Valve seat ring (delivery side)	3
84	F082200220	Delivery valve poppet SH20-22-24	3
	F082200260	Delivery valve poppet SH26-28-30	3
85	F090200170	Delivery valve spring SH20-22-24	3
	F090200210	Delivery valve spring SH26-28-30	3
86	F021300390	Delivery valve guide	3
87	F208006710	Valve assembly SH20-22-24	3
	F208006720	Valve assembly SH 26-28-30	3
88	F821203100	Plug G 1/8"	4
89	F872042000	Aluminum washer Ø 10	4
91	F801203030	Quick coupling G 3/8"	1
94	F871151932	Screw M20 x 300 Spec.	8
95	F063200150	Valve cover	3
96	F871135953	Screw M14 x 45 Spec.	12
97	F010500050	Anti-extrusion ring	3
98	F881010207	O-ring Ø 17 x 3.53	3
99	F064200320	Manifold	1
100	680086	Conical seal G 1/2"	2

REPAIR KITS

Item	SH20	SH22	SH24	SH26	SH28	SH30
65-66-68-69-71-73-76-97-98	F1111	F1112	F1113	F1114	F1115	F1116
81-83-97-98	F1117					
1-4-13-17-20-22-26-28-30-33 44-49-54-56-57-65-66-68-69 71-73-76-81-83-89-97-98	F1119	F1120	F1121	F1122	F1123	F1124

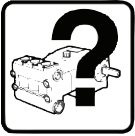

17. TROUBLE SHOOTING



THE PUMP DOES NOT PRODUCE ANY NOISE: the pump is not primed and is running dry!

- No water in the inlet line
- The valves are blocked
- The pressure line is closed and does not allow the air to get out the fluid end.

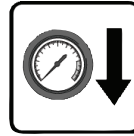

INSUFFICIENT PUMP PRESSURE:

- The nozzle is (or has become) too large.
- RPM are less than rated
- Excessive leakage from pressure packings
- Excessive amount of water by-passed by the pressure regulating valve or faulty valve operation.
- Worn out valves.



THE PUMP KNOCKS:

- Air suction.
- Insufficient feeding:
 - bends, elbows and fittings along the suction line throttle the amount of water which passed through.
 - too small inlet filter.
 - dirty inlet filter.
 - the feeding pump, where provided is not of the suitable type or provides insufficient pressure or volume.
- The pump is not primed due to insufficient feeding or the delivery line is closed during start up.
- The pump is not primed because some valves are stuck (i.e pump inactivity for long time).
- Jammed or worn out valves.
- Worn out pressure packings.
- The pressure regulating valve does not work properly.
- Clearance in the drive system.
- RPM are higher than rated.

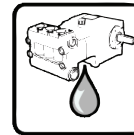

EXCESSIVE WATER LEAKAGE FROM THE PUMP:

- Pressure packing are excessively worn out (due to normal wear or excessive cavitation).
- Worn out plungers

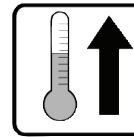

OVERHEATED PUMP:

- The direction of rotation is not correct.
- Pump is overloaded (pressure or RPM over the rated values).
- The oil level is too low or the oil is not of a suitable type or fully used
- Water in the oil
- Excessive belt tension or incorrect alignment of the joint (where provided).
- Excessive inclination of the pump during operation.



THE PUMP DOES NOT DELIVER THE RATED VOLUME:

- Insufficient feeding (due to the cause listed above).
- RPM are less than rated.
- Excessive amount of water by-passed by the pressure regulating valve.
- Worn out valves
- Excessive leakage from pressure packings

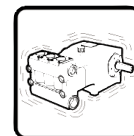

PIPE VIBRATIONS OR KNOCKING:

- Air suction.
- The pressure regulating valve does not work properly.
- The by-pass line is undersized.
- Jammed up valves.
- Drive transmission motion is irregular.

MAINTENANCE LOG

HOURS & DATE

OIL CHANGE							
GREASE							
PACKING REPLACEMENT							
PLUNGER REPLACEMENT							
VALVE REPLACEMENT							



GP Companies, Inc.
1174 Northland Drive
Mendota Heights, MN 55120
Phone: 651.686.2199 Fax: 800.535.1745
www.generalpump.com email: sales@gpcompanies.com

Ref 300032 Rev.C
08/07