

# Owner's Manual

- *Installation*
- *Use*
- *Maintenance*

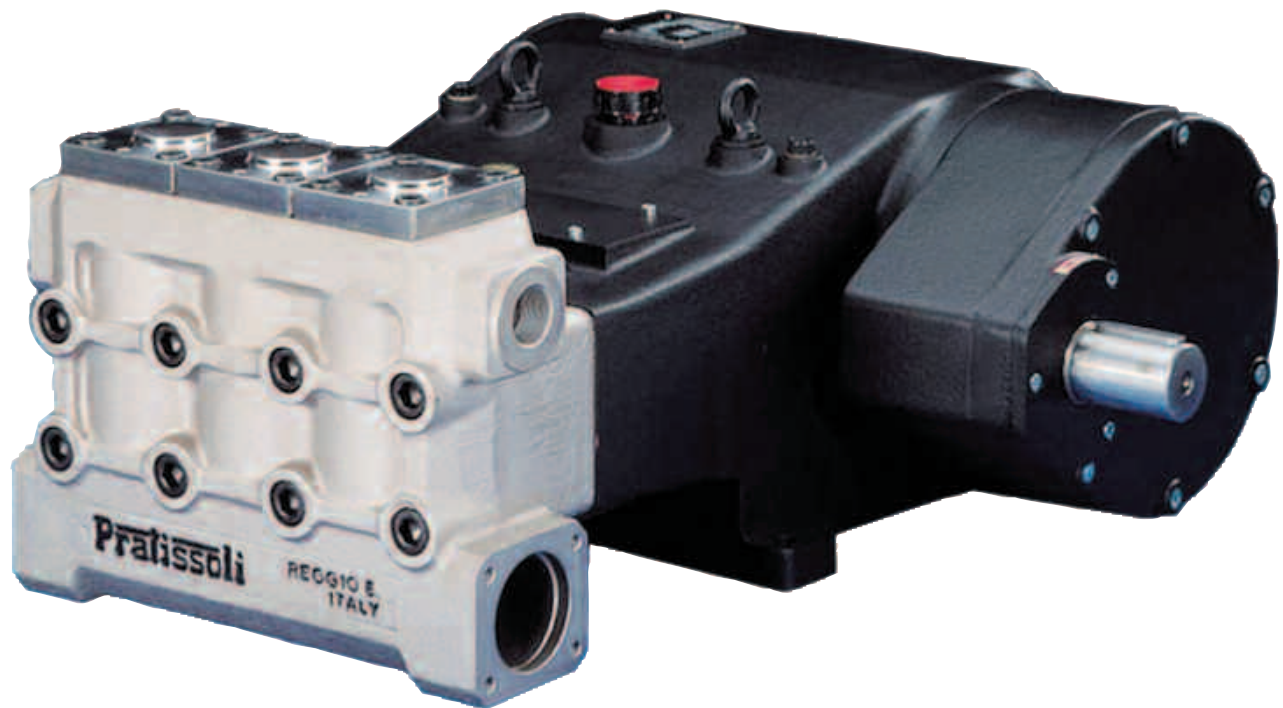

**INDEX**

<b>1.</b>	<b>INTRODUCTION</b>	Page 3
<b>2.</b>	<b>SYMBOL DESCRIPTIONS</b>	Page 3
<b>3.</b>	<b>SAFETY</b>	Page 3
	3.1 General warnings for safe operation	Page 3
	3.2 High pressure unit safety requirements	Page 3
	3.3 Safety of operation	Page 4
	3.4 General procedures for high pressure lance/gun operation	Page 4
	3.5 Safety of maintenance	Page 4
<b>4.</b>	<b>PUMP IDENTIFICATION</b>	Page 5
<b>5.</b>	<b>TECHNICAL FEATURES</b>	Page 5
<b>6.</b>	<b>DIMENSIONS AND WEIGHT</b>	Page 5
<b>7.</b>	<b>GENERAL INFORMATION ABOUT SPECIFIC PUMP USE</b>	Page 6
	7.1 Water temperature	Page 6
	7.2 Maximum flow and pressure ratings	Page 6
	7.3 Lowest operating RPM	Page 6
<b>8.</b>	<b>CONNECTION AND PLUGS</b>	Page 6
<b>9.</b>	<b>PUMP INSTALLATION</b>	Page 7
	9.1 Positioning	Page 7
	9.2 Direction of rotation	Page 7
	9.3 Water connections	Page 7
	9.4 Suction line	Page 7
	9.5 Filtration	Page 8
	9.6 Delivery time	Page 8
<b>10.</b>	<b>START UP AND RUNNING PROCEDURES</b>	Page 9
	10.1 Before start up	Page 9
	10.2 Starting up	Page 9
	10.3 Water leakage	Page 9
<b>11.</b>	<b>MAINTENANCE INSTRUCTIONS</b>	Page 10
	11.1 Crank mechanism maintenance	Page 10
	11.2 Fluid end maintenance	Page 10
	11.3 Pumping unit maintenance	Page 12
<b>12.</b>	<b>SCREW CALIBRATION</b>	Page 14
<b>13.</b>	<b>MAINTENANCE TOOLS</b>	Page 14
<b>14.</b>	<b>PUMP STOPPED FOR LONG TIME</b>	Page 14
<b>15.</b>	<b>PRECAUTIONS AGAINST FREEZING</b>	Page 14
<b>16.</b>	<b>EXPLODED VIEWS AND PARTS</b>	Page 15
<b>17.</b>	<b>TROUBLE SHOOTING</b>	Page 17

## 1. INTRODUCTION

MH high pressure water plunger pumps have been designed for long life industrial duties and provided they are correctly installed and maintained will give long trouble-free operation. Read and understand this manual before using your pump; it contains the necessary information for the correct installation, use and maintenance as well as some practical suggestion for trouble shooting.

Upon receipt of your pump, inspect for overall good condition and that no items are missing. Any missing item or damage should be reported before installing and starting the pump.

## 2. SYMBOL DESCRIPTIONS

**Warning**

Potential Danger

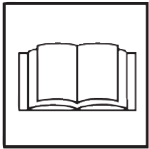

Read carefully and understand the manual before operating the pump

**Danger**

High Voltage

**Danger**

Wear protective mask

**Danger**

Wear goggles

**Danger**

Wear protective gloves

**Danger**

Wear protective boots

## 3. SAFETY

### 3.1 General warnings for safe operation

The misuse of a high pressure water unit and the non-observance of the pump installation and maintenance instructions may cause serious damages and/or injuries to people or properties or both.

Any Manufacturer/Operator requested to assemble/use a high pressure water unit should be competent to do so, should have the necessary knowledge on every high pressure component installed in the unit and on the precautions to be taken in order to guarantee the largest safety margins during operation. No precaution, so far as is reasonably practical, should be left out in the interest of safety, both from the Manufacturer and the Operator.

### 3.2 High pressure unit safety requirements

1. A safety valve should be installed in any delivery line and should be sized to discharge or by-pass the entire pump flow rate
2. High pressure unit components, with particular regard for those units working outside, should be adequately protected against rain, frost and heat.
3. Electric components and wiring should be provided with an adequate degree of protection, able to protect them against spray coming from any direction. They should also be suitable for working in a wet environment.
4. High pressure hoses and any other accessory under pressure should be sized in accordance with the maximum unit working pressure and must always work within the safety margins indicated by the nose/ accessory Manufacturer.
5. High pressure hose ends should be fastened to a steady object in order to prevent them from dangerous sweeping around, should they burst or come off their end fittings.
6. Proper safety guards should be provided to adequately cover transmission joints, pulleys, belts or auxiliary drives.



### 3.3 Safety of operation

The access into the area when a high pressure unit is working should be strictly prohibited to unauthorized personnel. The area should be suitably enclosed and its perimeter, so far as is reasonably practical, cordoned off and proper warning notices displayed in prominent positions.

Personnel authorized to enter that area should have been previously trained to do so and informed of the risks arising from failures, misuse and any foreseeable circumstance which may occur during operation. Before starting the pump unit and bringing it up to pressure the Operator is requested to carry out the following checks:

1. Make sure that a correct water supply to the pump is provided.
2. Make sure that water inlet filters are properly clean.
3. Electrical components and wiring, with special emphasis on connections, junction boxes, switches and supply cables should be free from external damage (i.e. exposed and broken wires) and adequately protected against water.
4. High pressure hose should not show apparent external wear and the fittings at both ends should be free from signs of erosion or corrosion.
5. Make sure that all fluids (lubricating oil for pump and engine, cooling water, hydraulic fluids) are at proper levels and in good condition.
6. Make sure the safety guards are in good condition.

The work should stop immediately and the pressure must be released in the event that leakage becomes apparent or if any person becomes aware of a change in condition or any hazard existing or being introduced. Any failure must be promptly reported and then checked personnel.



### 3.4 General procedures for high pressure gun/lance operation

1. The Operator should take reasonable care for the safety of himself and of other persons who may be affected by his acts or omission at work. His actions should always be governed by his good sense and responsibility.
2. The Operator should wear suitable waterproof protective clothing, having regard to the type of work being undertaken. The clothing set should include adequate hand protection, suitable boots able to ensure proper grip on wet floors, helmet provided with full face shield, waterproof garment providing full cover to the Operator, including his arms.  
As most water jets produce noise levels in excess of

90 dB(A) suitable ear protection is advised.

**NOTE:** *it must be emphasized that whereas protective clothing provides adequate protection against spray and flying particles, it does not constitute complete protection against the direct impact of the water jet. Additional protections in the form of suitable metal shields or barriers may be necessary for certain jetting operation.*

3. In most jetting operations it is an accepted practice to employ a team of Operators consisting of two members at least, in order to provide mutual assistance in case of need and to rotate their duties in case of long and heavy work. While the first Operator holds the gun, the second Operator attends the pump unit, keeping close watch on the first Operator for signs of difficulty or fatigue, and watching the surrounding area for intrusion by other persons or unsafe situations. If required, he will shut off the pressure unit until it is safe to continue.
4. The area in which the work is to proceed should be clear of loose items and debris to prevent tripping and slipping hazards.
5. The water jet should be directed only and always against the workpiece even during preliminary operating tests prior to starting work.
6. Where applicable, proper side shields should be suitable placed to safeguard personnel and equipment against contact with grit or particles removed by the water jet.
7. On no account must the Operator be distracted during operation until the jet has been stopped. Personnel having reason to enter the water jetting area should wait until the jet is stopped and his presence known.
8. Each team member must always be aware of the actions and intentions of other team members in order to prevent any dangerous misunderstanding occurring during jetting operation.
9. The pump unit should not be started and brought up to pressure unless each team member is in his designated position, the nozzle directed to the workpiece and the lance or gun securely held.

### 3.5 Safety of maintenance

Apart from the working pressure regulation no attempt should be made to adjust any nut, hose, fitting, etc., while that part of the system is under pressure. The pump should be stopped and any pressure in the line released prior to making any adjustments.

1. The high pressure water unit should be maintained in accordance with the Manufacturer's instructions.
2. The unit should be maintained only by competent personnel
3. Service and maintenance should be carried out with proper tools in order to prevent any damage on high pressure connections and fittings.
4. Use of other than original spar parts is strictly forbidden.

## 4. PUMP IDENTIFICATION

Each pump is fitted with a rating plate (see Fig. 1) containing the following information:

2. pump model and version
3. serial number
4. max RPM
5. max operating pressure (bar)
6. oil capacity (ltr) and oil specification
7. gear box ratio
8. max flow rate (l/min)

Pump model, pump version and serial number should be specified when ordering spare parts. Should the pump be modified (i.e by changing the original version) than any change should be mentioned on the rating plate for future reference.

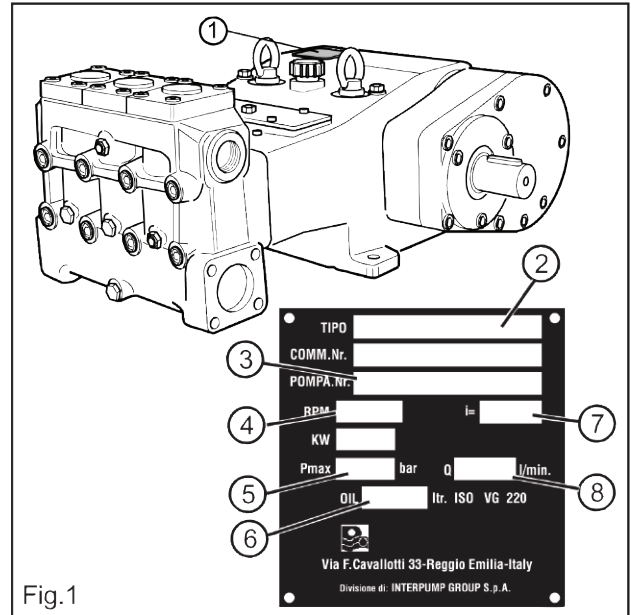

Fig.1

## 5. TECHNICAL FEATURES

Model	1800 RPM (R = 1:3.29)						1500 RPM (R = 1:2.65)					
	Flow Rate		Pressure		Power		Flow rate		Pressure		Power	
	GPM	l/min	PSI	bar	Hp	kW	GPM	l/min	PSI	bar	Hp	kW
<b>MH45</b>	49.4	187	4350	300	147	108	51.2	194	4350	300	152	112
<b>MH50</b>	61.0	231	3600	250	151	111	63.4	240	3500	240	151	111
<b>MH55</b>	74.0	280	2950	205	149	110	76.6	290	2900	200	152	112
<b>MH60</b>	88.0	333	2550	175	152	112	91.1	345	2400	165	149	110
<b>MH65</b>	103	391	2100	145	148	109	107	405	2050	140	148	109

## 6. DIMENSIONS AND WEIGHT

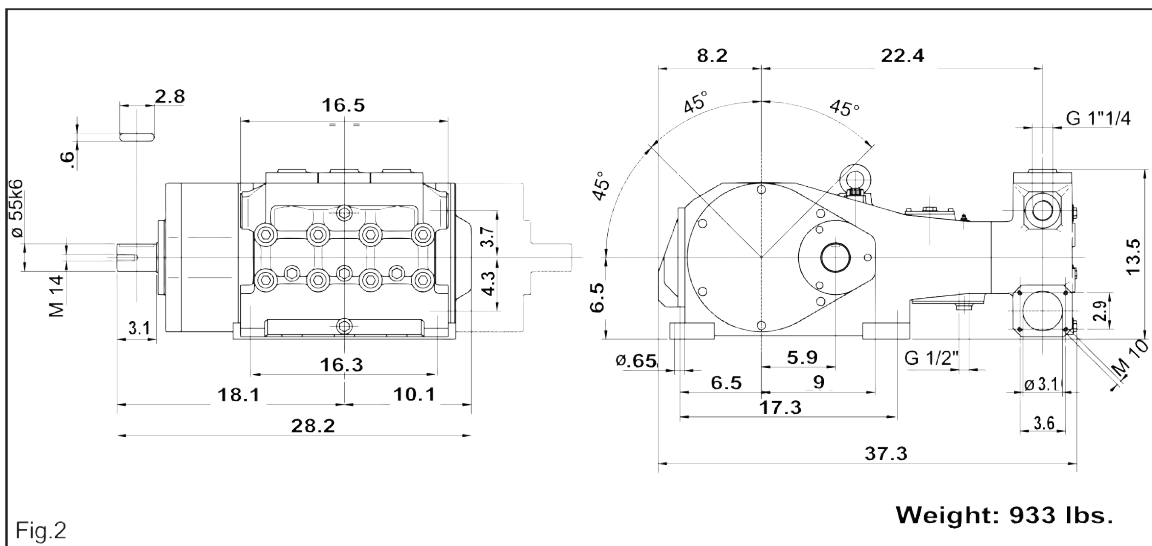

Fig.2

Weight: 933 lbs.



## 7. GENERAL INFORMATION ABOUT PUMP USE



The MH pump has been designed to pump fresh filtered water at room temperature.

### 7.1 Water temperature

Water temperature is critical for the pump life, the higher it is, the more likely it is to create cavitation, resulting in premature seal and valve failures.

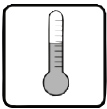

Below is the temperature chart and relevant limitations:

<104°F	Water is considered to be at room temperature.
from 104°F to 140°F	<p>feed the plunger pump with a centrifugal pump supplying at least twice the plunger pump volume at 30 to 45 PSI</p> <p>reduce pump rated RPM by 30% to 50%</p> <p>Make sure the crankshaft turns as indicated by the arrows located neat the drive shaft projection</p>
>140°F	standard pump not suitable, contact our Customer service Department

### 7.2 Max flow and pressure ratings

The performance data indicated in the catalog and on the rating plate refer to the maximum performance of the pump. The use of the pump below the rated performances does not allow the drop in power absorbed to be balanced by altering the pressure or volume of the pump above its maximum value.

### 7.3 Lowest operating RPM

The lowest operating speed of the crankshaft for all MH's (all versions is 350 RPM).

## 8. CONNECTIONS AND PLUGS

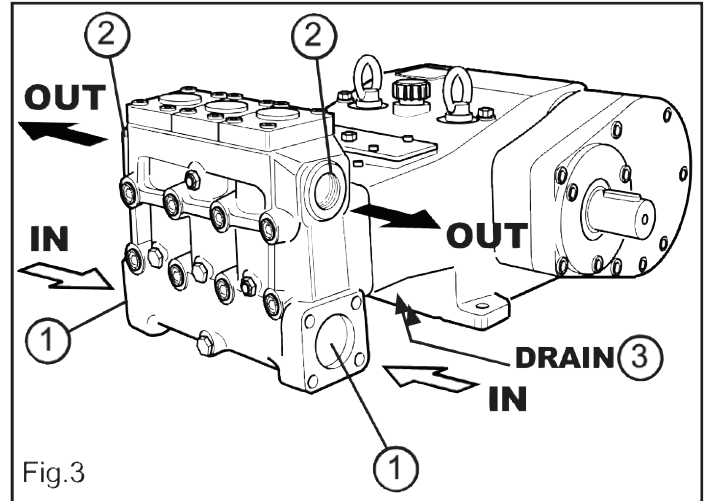

Fig.3

MH pumps are provided with (Fig. 3):

- 1 - 2 inlet ports IN Ø 3"-NPT  
Suction line connection to any of the two inlet ports is acceptable, the port not being used should be sealed with the correct plug.
- 2 - 2 outlet ports OUT 1-1/4" NPT
- 3 - 1 hole DRAIN provided underneath the crankcase and designed to drain out the water leakage of the pressure packings. **This hole must always be left open (see paragraph 10.3 Fig. 7-page 9).**

## 9. PUMP INSTALLATION

### 9.1 Positioning

The pump should be installed flat on a rigid base by means of the four feet  $\varnothing$  16.5 mm. The base should be rigid enough to avoid any misalignment or flexing of the pump/transmission coupling axis due to the torque involved during operation.

**On no account should the pump be installed in such a way its fluid end rests on the base where the pump is mounted. The fluid end should be left free and not subjected to any force (Fig. 4).**

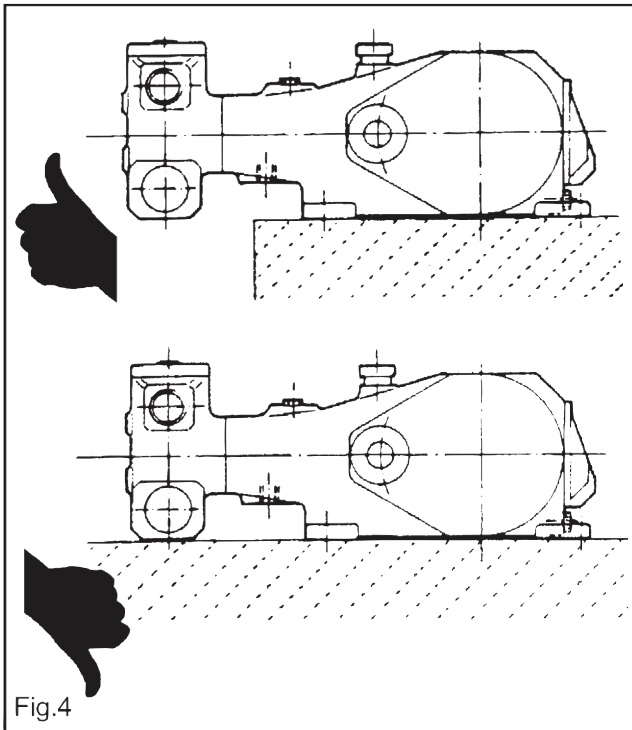

Fig.4

### 9.2 Direction of rotation

Fig 5 shows the correct direction of rotation looking at the pump from the fluid end side. Two arrows stamped on the crankcase nearby the crankcase provide the information as well.

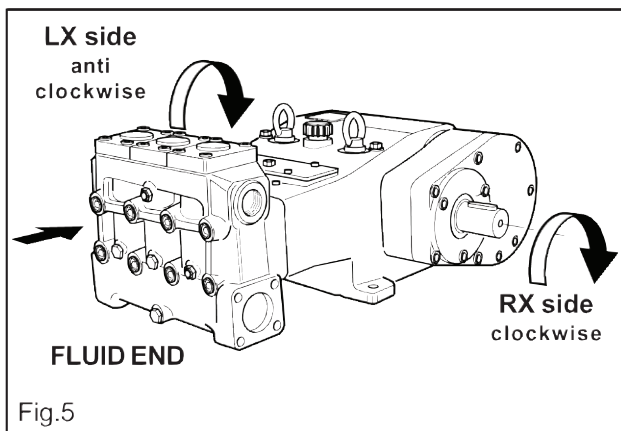

Fig.5

### 9.3 Water connections

In order to isolate the high pressure equipment from the pump vibrations it is suggested, where applicable, to use flexible hoses for both suction and delivery lines at least for the first length. The flexible suction hose must be rigid enough to prevent it from collapsing during the suction stroke, when a partial vacuum may occur.

### 9.4 Suction line

Plunger pumps are not self priming therefore a positive suction head should always be provided. Information for the correct suction line:

1. Internal diameter should be at least 3", in any point, possibly larger depending on the drop in pressure due to the length and shape of the line.
2. Should be as straight as possible minimizing changes in size and direction and positioned in such a way to allow air pockets and bubbles to escape.
3. Should be perfectly airtight.
4. Should be completely free from 90° elbows, diameter reductions, counter slopes, "T" connections and should not be connected to other pipelines.
5. Should be positioned in such a way to prevent the pipe emptying after the pump stops.
6. Do not use high pressure flexible hoses for the suction line.
7. Do not use high pressure hydraulic fittings like 90° elbows, high pressure adapters, high pressure 3 or 4 way nipples and so on.
8. Do not install any kind of detergent injector along the suction line.
9. Do not install standing valves, check valves or other kind of one-way valves.
10. Make sure that the feed tank capacity and the water minimum level do not give rise to turbulence at the tank outlet port, which, in turn, might create cavitation at the pump.
11. Do not connect the by-pass line from the valve directly to the pump suction line.
12. The water flow from the valve should be directed back in the tank. Make sure that the by-pass and tank feeding flows do not give rise to turbulence at the tank outlet port, which, in turn, might create cavitation at the pump. Proper baffle plates should be provided inside the tank.
13. Before connecting the suction line to the pump inlet port make sure the pipe is perfectly clean inside.

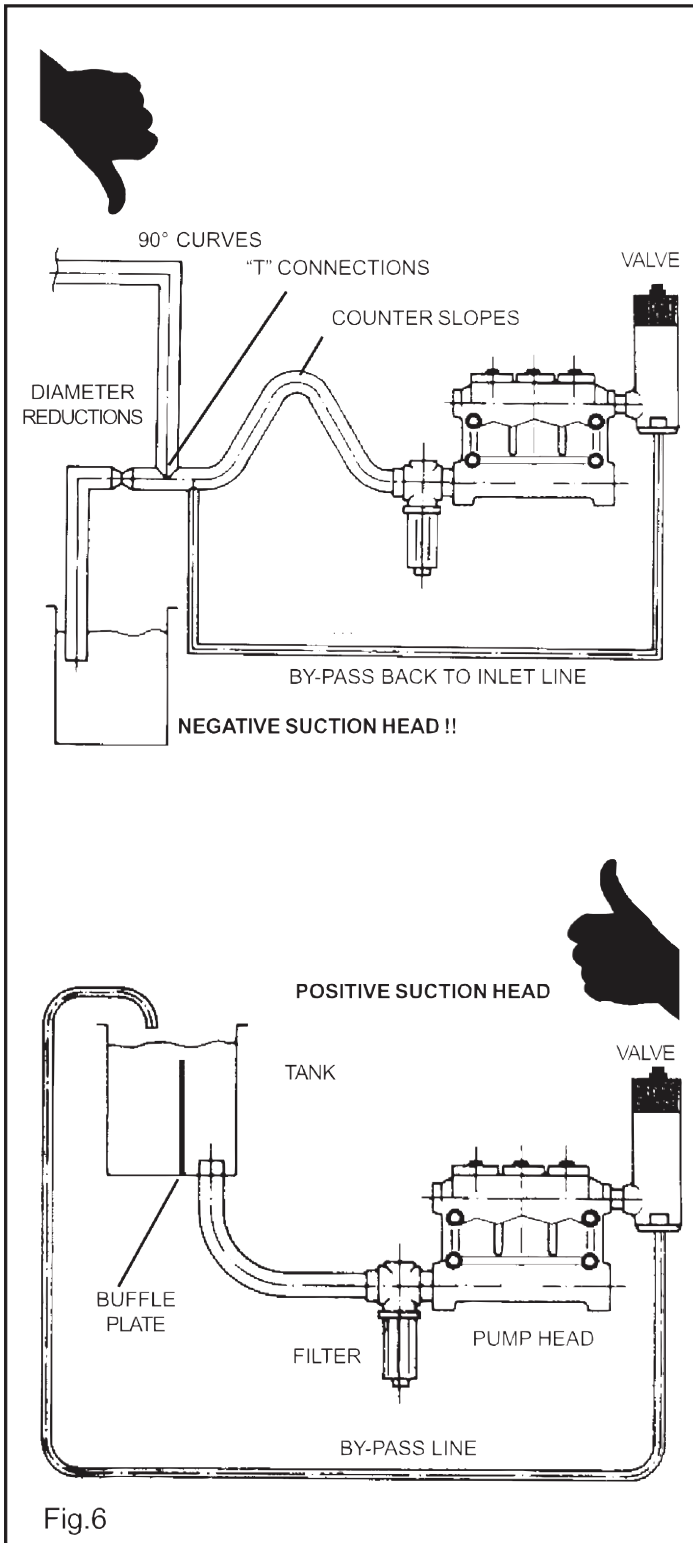

Fig.6

### 9.5 Filtration

All pumps require a suitable filter. The filter should be installed as close as possible to the pump, should allow easy inspection and have the following characteristics:

1. The filter capacity should be at least three times the rated pump volume.
2. Filter port diameters should not be smaller than the pump inlet ports.
3. Filtration degree in between 50 and 80 mesh (360 to 200 microns).

**IMPORTANT NOTE:** In order to properly safeguard the pump it is very important to plan cleaning of the filter with a frequency depending on the water quality, filtration degree and number of hours of each application.

### 9.6 Delivery line

For a correct delivery line comply with the following instructions:

1. The first length of delivery hose should be flexible in order to isolate the pump vibrations from the rest of the system.
2. Use only high pressure hoses and fittings able to guarantee the largest possible safety margins in any working conditions.
3. A suitable relief valve should be installed in the delivery line.
4. Use glycerine filled pressure gauges, as the most suitable for pulsating loads.
5. When designing the delivery line, take into proper account the unavoidable drop in pressure, due to its length and size.
6. If necessary, the effects of the pump pulsations can be reduced by installing a proper pulsation dampener in the pressure line.



## 10. START UP AND RUNNING PROCEDURES

### 10.1 Before start up

Before start up make sure that the following conditions have been complied with:

1. Suction line should be connected: **the pump must never run dry.**
2. Suction line must be perfectly air-tight.
3. Any ON-OFF valve in between the pump and water source should be open and make sure the water gets into the pump freely.
4. Set the pressure line in dump mode in order to let the air in the pump get out easily thus facilitating the pump priming.
5. Make sure all suction/delivery line connections are fully tightened.
6. Joint alignment, belt tightening and PTO shaft inclination tolerances should remain within the values indicated by the transmission Manufacturer.
7. Make sure the oil level is correct.

**Note:** in case the pump has not run for a long period of time check the suction and delivery valves for scaling (see paragraph 11.2).

### 10.2 Starting up

1. Pump and motor/engine should start offload, set the regulating valve to zero or set the pressure line in dump mode by means of proper dumping devices.
2. When starting the pump up for the first time or after every wiring re-connection check for the proper direction of rotation.
3. Check that the rotating speed does not exceed the rated value.
4. Before putting the pump under pressure let it run for some time until the oil flows freely.
5. Before stopping the pump release the pressure from the system by operating the dump device or by releasing the regulating valve and reduce RPM to a minimum (diesel applications).

**Note:** in case of feeding by a centrifugal pump, make sure that the plunger pump start only when the correct inlet pressure is provided.

### 10.3 Water leakage

During operation a small amount of water (a few drops a minute) is released from the pump fluid end; this leakage is designed to provide lubrication for the pressure packings. The leakage is drained out of the pump through a hole in the lower cover (Fig. 7). **This hole must always be kept open.**

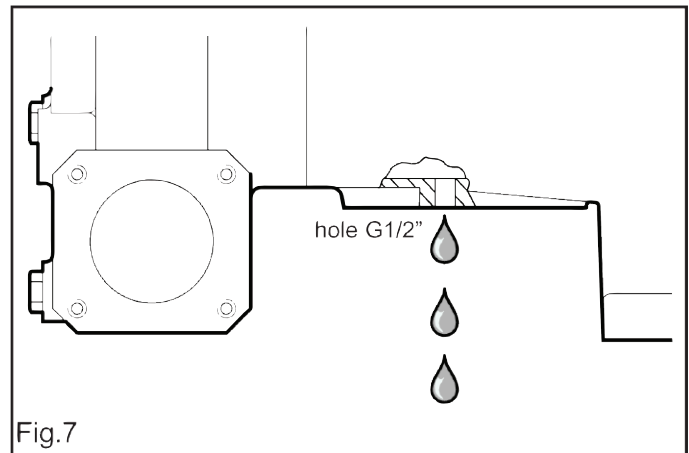

## 11. MAINTENANCE INSTRUCTIONS

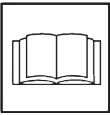

### 11.1 Crank mechanism maintenance.

Check oil level on a weekly basis by means of the two oil dipsticks (1, Fig. 8) provided with notches for min. and max. levels.

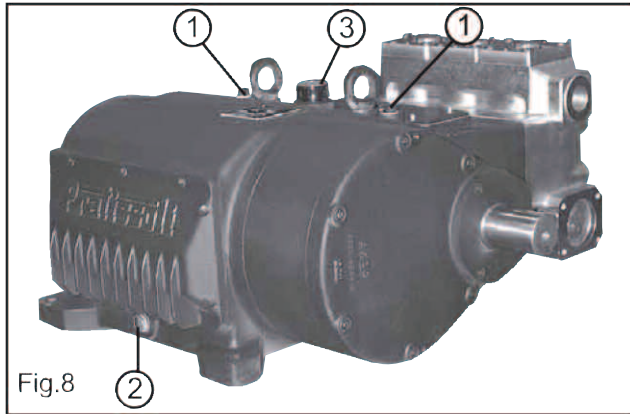

If necessary, top up from the oil plug 3, Fig. 8. Check the oil when cold and change the oil when still hot (pump still at working temperature.). In order to drain the oil from the pump remove the magnetic plug 2, Fig. 8. At every oil change clean the magnetic plug 2, Fig. 8 and check the lower cover of Fig. 7 for grease sediments or deposits.

OIL CHANGES	Hours	Qty.	Oil Type
First Change	50	14.8 quarts	ISO 220
Subsequent Changes	500		

**Oil should be changed at least once a year.**

Recommended oils:

BRAND	TYPE
AGIP	ACER 220
ARAL	MOTANOL HP 220
AVIA	AVILUB RSL 220
BP	ENERGOL HL 220
CASTROL	ALPHA ZN 220
ESSO	NUTO 220
FINA	SOLNA 220
IP	HYDRUS 220
MOBIL	DTE OIL BB
SHELL	TELLUS C 220
TEXACO	REGOL OIL 220
TOTAL	CORTIS 220

### 11.2 Fluid end maintenance

The fluid end does not require periodical maintenance. Service operations are limited to valve inspection and/or replacement, when necessary.

In order to remove the valves:

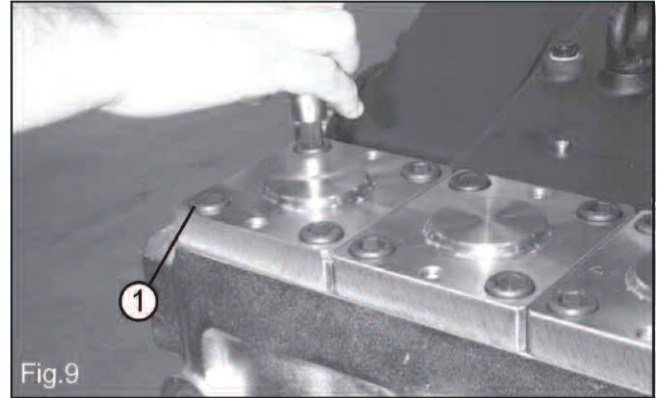

Loosen and remove the valve cover screws. 1, Fig. 9

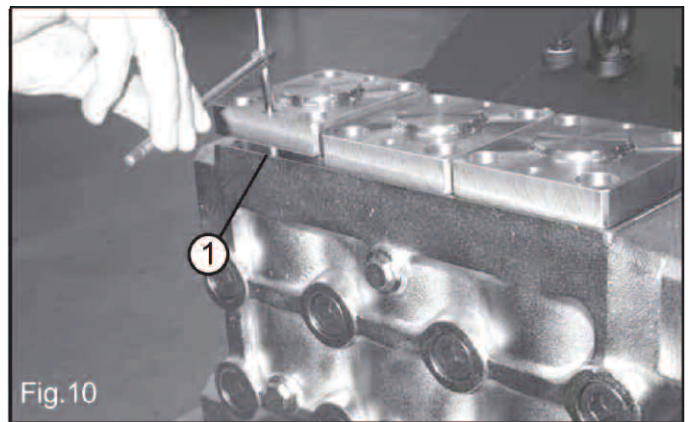

Tighten the two grub screws, 1, Fig. 10 of each valve cover until the complete valve unit moves upward enough to allow easy extraction.

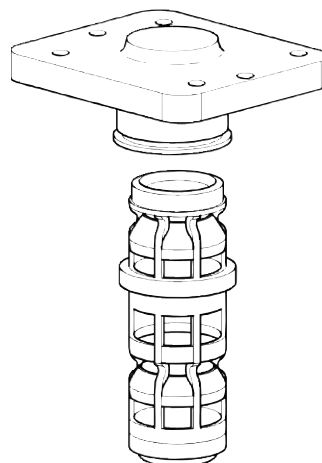

Valve components of each valve unit are screwed together in one single block and therefore they can be easily serviced, replaced and installed back in place. Separating the various components of the valve unit is carried out by means of simple tools as shown in Fig. 11, 12 and 13 on the next page.

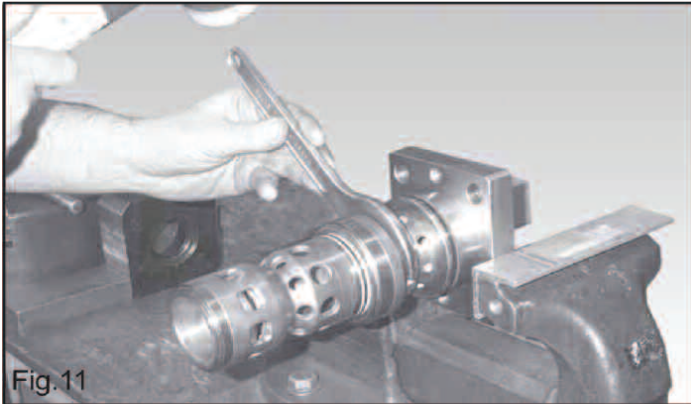

Fig.11

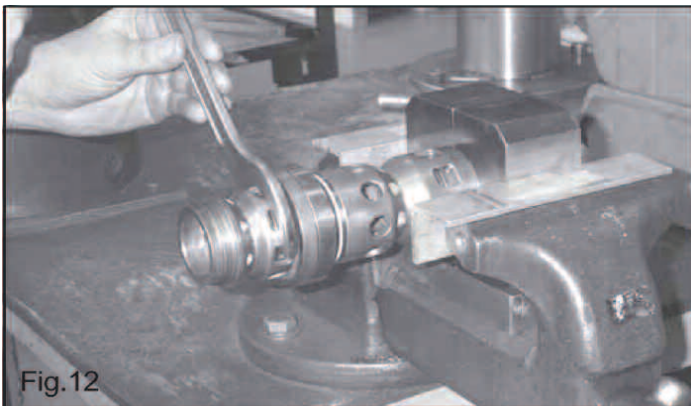

Fig.12

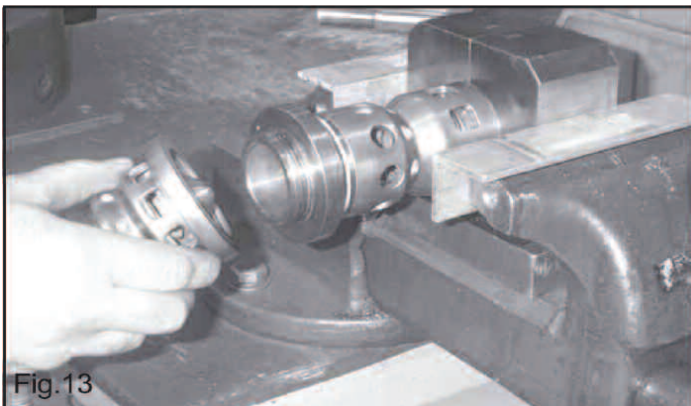

Fig.13

Check the valve components for wear and replace where necessary.

**Every time valves are inspected all o-rings of the valve units and valve covers should be replaced.**



Reassemble the valve units and fit them back in the fluid end. Valve cover screws should be tightened with a torque wrench set for 86.7 ft. lbs.



**IMPORTANT:**

**BEFORE REPOSITIONING THE VALVE UNITS CLEAN AND PERFECTLY DRY ALL VALVE HOUSINGS INSIDE THE FLUID END (SEE ARROWS).**

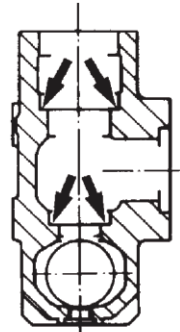

Fig.14

Should excessive scaling inside the fluid end hinder the valve extraction open one of the two lateral inlet ports, remove the three plugs 1, Fig. 15, insert our special tool p/n F200030090 (2, Fig. 15), or a corresponding one, and push the valve unit out as shown in Fig. 15.

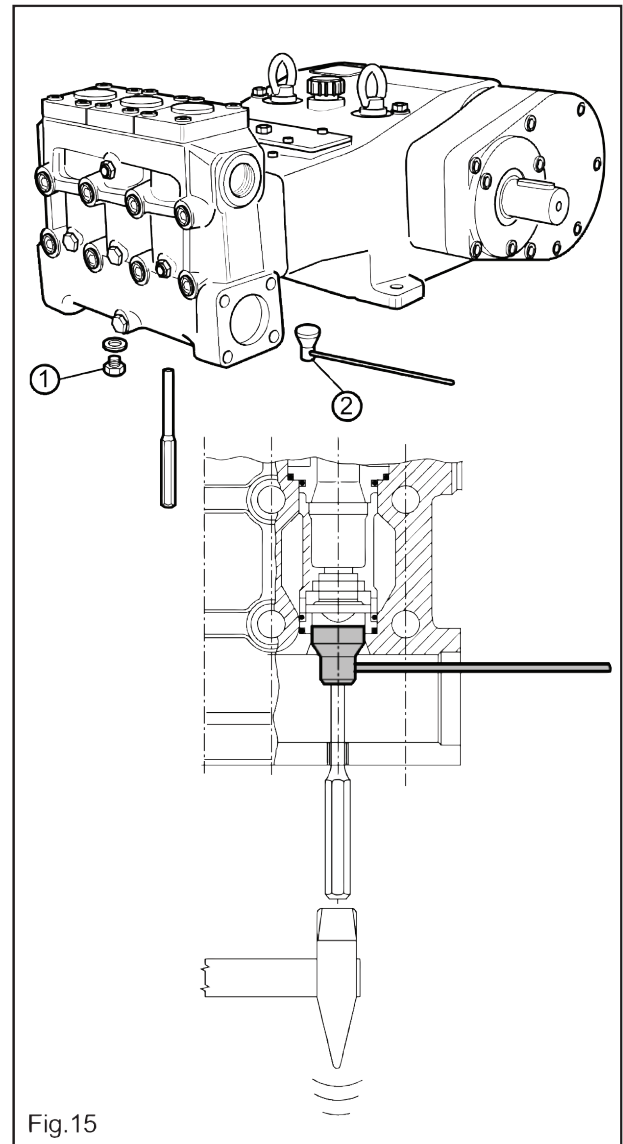
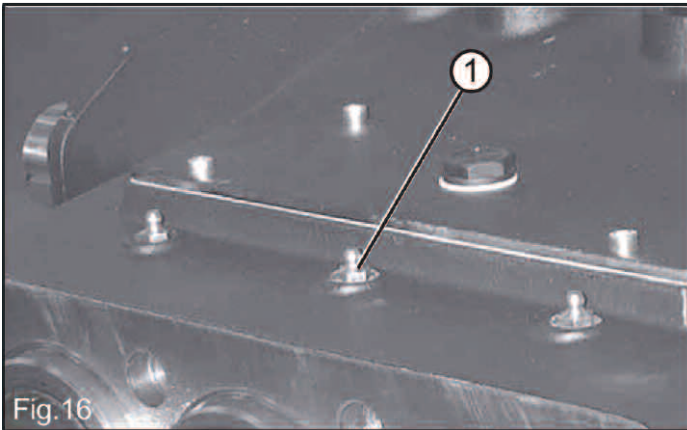

Fig.15



### 11.3 Pumping unit maintenance

The only maintenance operation required for the pumping unit is the pressure packings greasing through the proper greasers (1, Fig. 16).



**Greasing should be carried out at even intervals at least every 100 hours** by means of a hand pump. Stop greasing when the pump trigger becomes harder to operate: that means the grease chamber is full. Use top quality silicone grease (i.e. DANKELL OCILIS 250, penetration coefficient 290 or a corresponding one).

Periodically check the amount of water drained out by the pump through the hole provided in the lower cover (Fig. 7, page 9). It clearly shows the pressure packing state of wear; replace them if water dripping becomes continuous and not intermittent.

For inspecting the pumping unit remove the head by loosening the eight head screws (1, Fig 17).

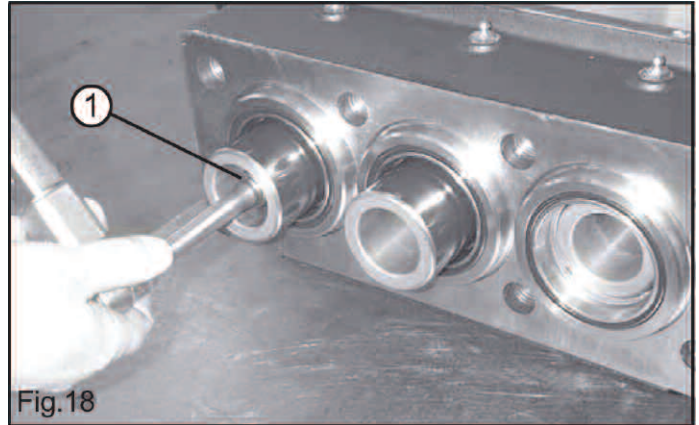
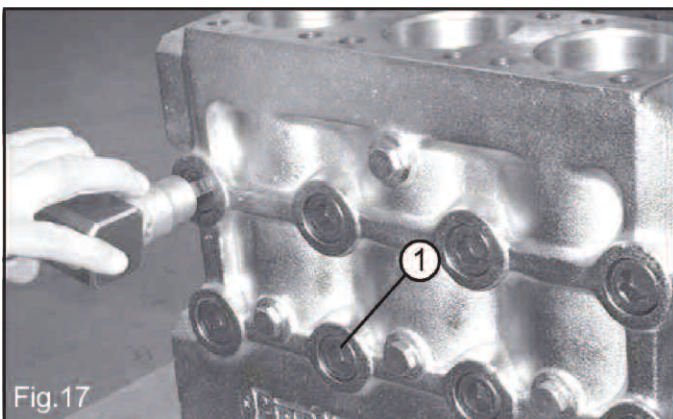

Loosen and remove the plunger screws (1, Fig. 18).

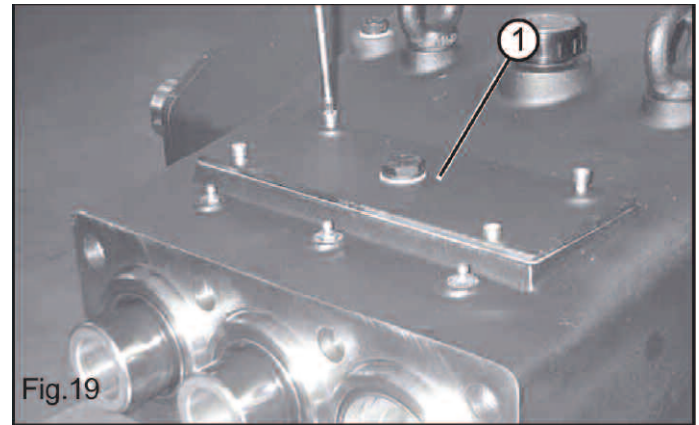

Remove the upper cover by loosening the four screws (1, Fig. 19).

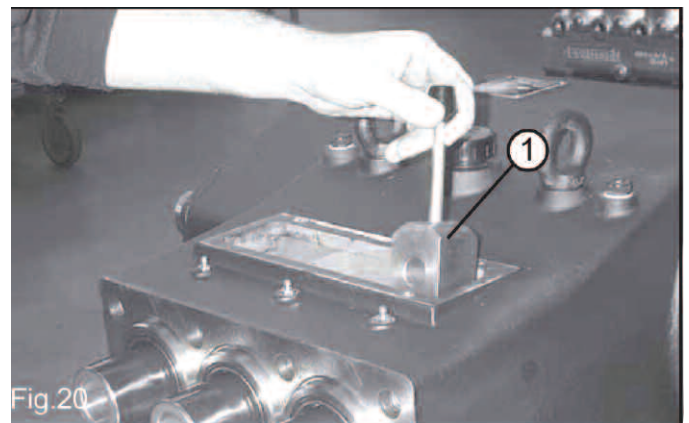

Push the plungers forward by rotating the crankshaft, then introduce our tool pn/ F200030060 (or equivalent) in between the piston guide and the packing support (1, Fig. 20).

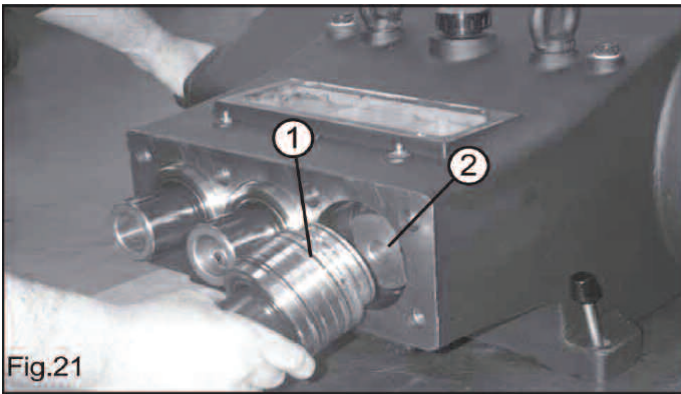

Fig.21

With the tool in place, rotate the crankshaft until the packing support is pushed out together with plungers and cylinders (Fig. 21). Repeat the operation for each pumping unit.

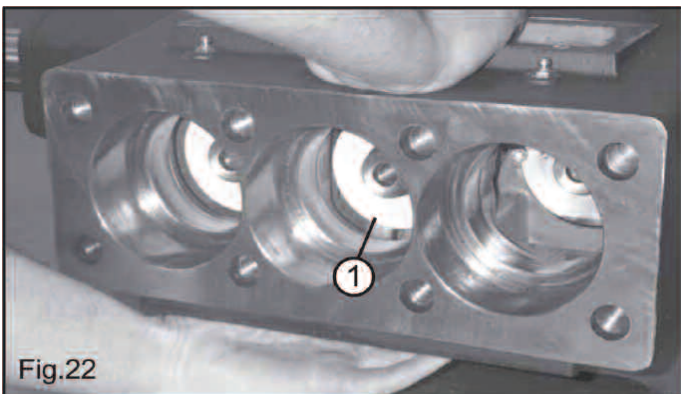

Fig.22

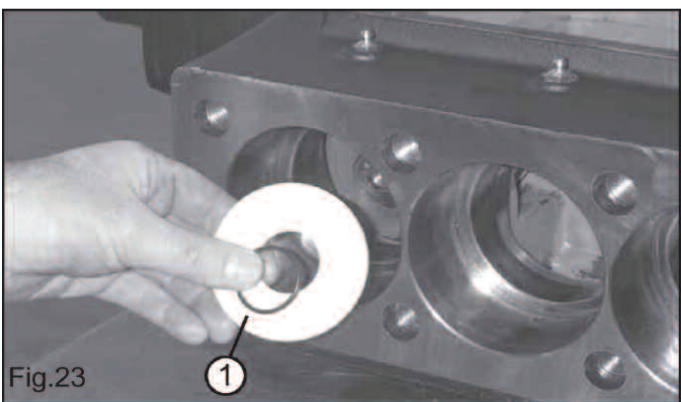

Fig.23

Remove the wipers from the piston guides (1, Fig. 22 and Fig. 23).



Fig.24

Separate the pumping unit components and check them for wear. Pressure packing replacement is carried out by hand without need of special tools (Fig. 24)

A little bit of grease helps when sliding the packings into the packing support. **Pressure packings and o-rings should always be replaced at every disassembling of the pumping unit.**

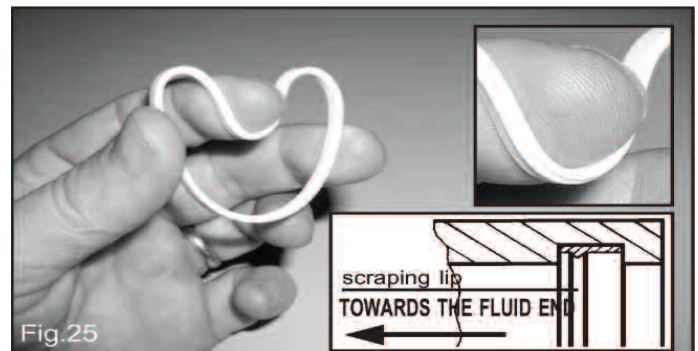

Fig.25

In order to fit the new scraper in place shape it manually as shown in Fig. 25.

**VERY IMPORTANT!** The scraper is provided with an internal lip which performs the correct scraping effect only if oriented toward the fluid end. See window inside Fig. 25. Put the pumping unit components together and fit them back in the pump crankcase. Tighten the plunger screws (1, Fig. 18) with a torque wrench set for 72.3 ft. lbs. Grease the pressure packings through the greasers (2, Fig. 23) by means of a hand pump. Stop greasing when the pump trigger becomes hard to operate: that means the grease chamber is full. Head back in place, head screws tightened at 260.3 ft. lbs.



## 12. SCREW CALIBRATION



Screw calibration is to be carried out by means of a torque wrench only:

DESCRIPTION	Ft. Lbs.	N-m	Kgm.
Valve cover screws	86.7	117.6	12
Head Bolts	260.3	353	36
Plunger bolts	72.3	98	10
Connecting Rod Screws	54.2	73.5	7.5

## 13. MAINTENANCE TOOLS



The following tools are designed to facilitate mounting and dismounting operations of some pump components:

for disassembling:

-packing support extractor F200030060

-main gear (gear box) F200030010

- valve extractor F200030090

## 14. PUMP STOPPED FOR LONG TIME



Before starting the pump for the very first time after a long period from the date of shipment check for the correct oil level, check the valves as indicated in chapter 11 and then comply with the starting procedures indicated in chapter 10. When a long inactivity is scheduled drain the entire suction and delivery line and then run the pump dry **only for a few seconds** in order to drain out the water collected inside the fluid end.

## 15. PRECAUTIONS AGAINST FREEZING



In the risk of freezing the following precautions should be taken:

- After use drain the entire suction and delivery lines (filter included) by means of discharging devices, provided and positioned specifically for this purpose along the lowest point of the lines.
- Run the pump only for a few seconds in order to drain the water collected inside the fluid end.

Or when applicable

- Add a recommended amount of anti-freeze into the water tank and run the pump until the anti-freeze works all through the system.



*If a pump is frozen or appears frozen ON NO ACCOUNT SHOULD THE PUMP BE OPERATED until the entire system has been thawed out.*

## 16. EXPLODED VIEW AND PARTS LIST

### MH

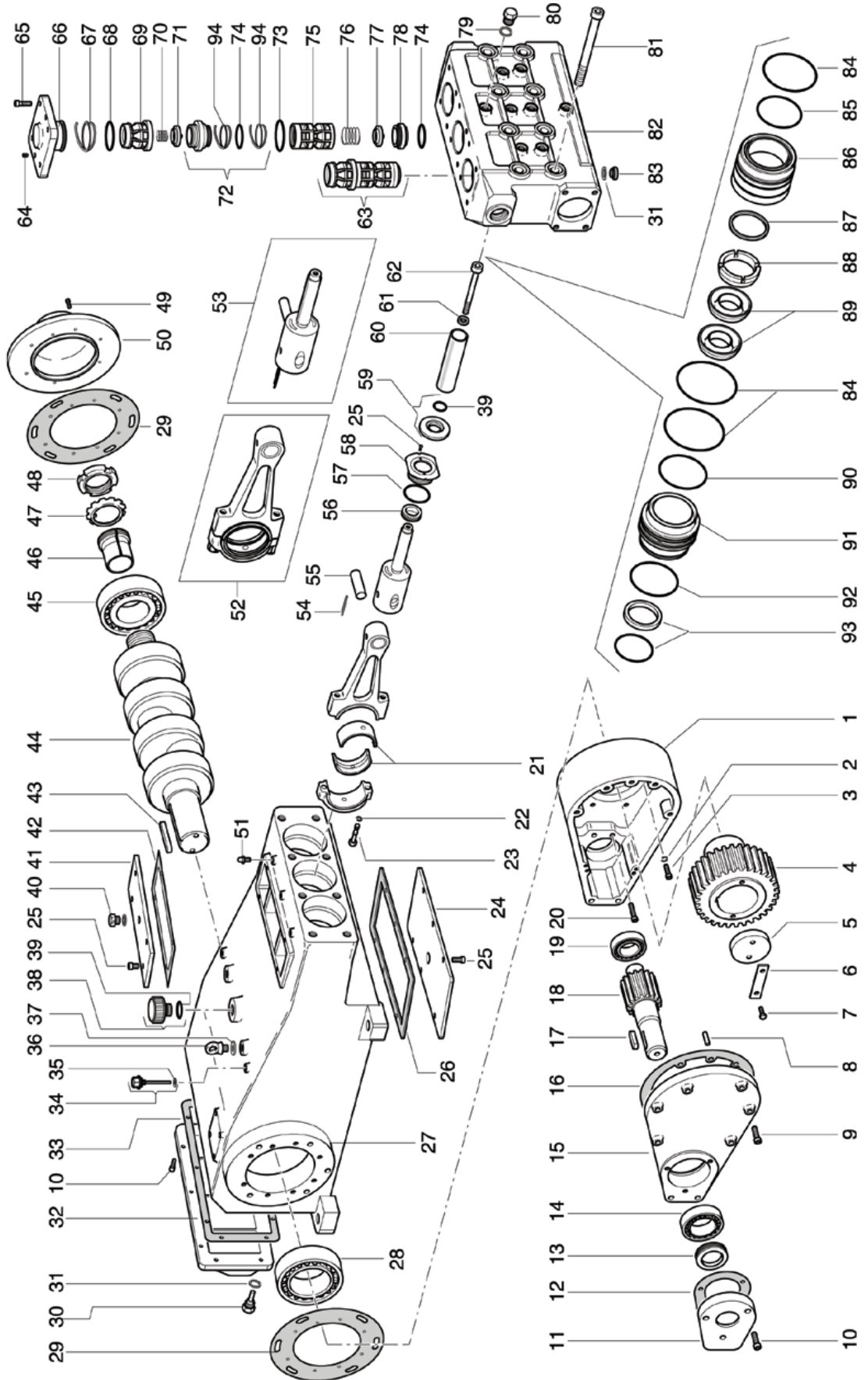

Item	Part #	Description	QTY.
1	F080100200	Gearbox body	1
2	F872047006	Lockwasher Ø12	8
3	F871131100	Screw M12 x 40	6
4	F052000060	Driven gear 1500 RPM (Z53)	1
	F052000080	Driven gear 1800 RPM (Z56)	1
5	F030000080	Retaining flange	1
6	F042000000	Flange screw retainer	1
7	F871024107	Screw M10 x 25	2
8	F872126004	Retaining pin Ø 12 x 40	3
9	F871125109	Screw M10 x 45	8
10	F871121151	Screw M8 x 16	13
11	F063100070	Pinion cover	1
12	F080600090	Gasket, pinion cover	1
13	F881080028	Seal, Ø 60x80x10	1
14	F811110012	Bearing	1
15	F063100050	Cover, gearbox	1
16	F080600080	Gasket, gearbox	1
17	F872098009	Key, pinion gear	1
	F872097013	Key, pinion gear Ø48	1
18	F052000070	Pinion 1500 RPM (Z20) MH	1
	F052000090	Pinion 1800 RPM (Z17) MH	1
	F052000190	Pinion 1500 RPM (Z20) Ø48	1
	F052000200	Pinion 1800 RPM (Z17) Ø48	1
19	F811110006	Bearing	1
20	F871131107	Screw, M12 x 50	2
21	F812000000	Bearing, connecting rod	3
22	F872046006	Lock washer Ø12	6
23	F035000070	Connecting rod bolt	6
24	F040000030	Lower cover	1
25	F871115152	Screw, M6 x 14	16
26	F080600070	Gasket, lower cover	1
27	F060100180	Crankcase	1
28	F811110021	Bearing	1
29	F080600050	Gasket, side	2
30	F801057002	Magnetic plug, G 1/2"	1
31	F872043002	Aluminum washer Ø1/2"	4
32	F063400500	Rear cover	1
33	F080600040	Gasket, rear cover	1
34	F001000000	Oil level dipstick	2
35	F872041501	Washer Ø3/8"	2
36	F872026003	Eye bolt M 16	2
37	F030000030	Washer, eyebolt	2 - 4
38	F801054027	Vented plug G 1"	1
39	F881010116	O-ring, Ø29.82 x 2.62	4
40	F801056002	Plug G 1/2"	1
41	F040000010	Top cover	1
42	F080600060	Gasket, top cover	1
43	F872101009	Key	1
44	F050000000	Crankshaft	1
45	F811111014	Bearing	1
46	F811920014	Bearing retainer bushing	1
47	F872069016	Washer MB16	1
48	F872020016	Nut KM16	1
49	F871131103	Screw M12 x 30	8
50	F063400460	Side cover	1
51	F801077003	Grease fitting M10 x 1	3
52	F250000040	Complete connecting rod	3
53	F250001080	Complete piston guide	3
54	F872142015	Retainer pin Ø 5 x 36	3
55	F071000050	Wrist pin Ø 35	3
56	F881081001	Oil seal Ø 35 x 47 x 8.5 Spec.	3
57	F881010128	O-ring Ø 72.69 x 2.62	3
58	F063400480	Oil seal cover	3
59	F205000010	Flinger washer	3
60	F024202600	Plunger MH45	3
	F024200270	Plunger MH50	3

**REPAIR KITS**

Item	MH45	MH50	MH55	MH60	MH65
61, 64, 85, 89, 90, 92, 93	F1190	F1191	F1192	F1193	F1194
31, 67, 68, 73, 94, 94	F1195				
2, 6, 12, 13, 16, 22, 26, 29, 31, 33, 35, 39, 42, 47, 51, 54, 56, 57, 61, 67, 68, 73, 74, 79, 84, 85, 89, 90, 92, 93, 94	F1196	F1197	F1198	F1199	F1200

Item	Part #	Description	QTY.
60	F024200280	Plunger MH55	3
	F024200290	Plunger MH60	3
	F024200330	Plunger MH65	3
61	F872040004	Washer Ø 14 Spec.	3
62	F871135518	Screw M14 x 140 inox MH45	3
	F871135510	Screw M14 x 80 inox MH50, 55, 60, 65	3
63	F208005230	Valve assembly	3
64	F871245356	Set screw M10 x 20	6
65	F871135102	Screw M14 x 40	12
66	F063002400	Valve cover	3
67	F881112003	Anti-extrusion ring	3
68	F881011252	O-ring Ø 70 x 4 Spec.	3
69	F021200280	Discharge valve guide	3
70	F090200050	Discharge valve spring	3
71	F082200060	Discharge valve poppet	3
72	F205000110	Discharge valve seat	3
73	F881011168	O-ring Ø 72 x 3 Spec.	3
74	F881011161	O-ring Ø 56 x 3 Spec.	6
75	F021200260	Inlet valve guide	3
76	F090200040	Inlet valve spring	3
77	F082200050	Inlet valve poppet	3
78	F081200060	Inlet valve seat	3
79	F872041300	Gasket washer Ø 1/4"	8
80	6801151	Plug NPT 1/4"	8
81	F871151172	Screw M20 x 200	8
82	F164000400	Manifold	1
83	F084000010	Plug 1/2" NPT	3
84	F881011054	O-ring Ø 96 x 2	9
85	F881011253	O-ring Ø 72 x 4 Spec.	3
86	F062200170	Cylinder MH45	3
	F062200180	Cylinder MH50	3
	F062200190	Cylinder MH55	3
	F062200200	Cylinder MH60	3
	F062200210	Cylinder MH65	3
87	F031300120	Spacer MH45	3
	F031300050	Spacer MH50	3
	F031300060	Spacer MH55	3
	F031300070	Spacer MH60	3
	F031300080	Spacer MH65	3
88	F031200110	Head ring MH45	3
	F031200210	Head ring MH50	3
	F031200220	Head ring MH55	3
	F031200230	Head ring MH60	3
	F031200250	Head ring MH65	3
89	F881020012	Packing MH45	6
	F881020014	Packing MH50	6
	F881020015	Packing MH55	6
	F881020016	Packing MH60	6
	F881020017	Packing MH65	6
90	F881011163	O-ring Ø 59.5 x 3 MH45	3
	F881011165	O-ring Ø 65 x 3 MH50	3
	F881011167	O-ring Ø 69.5 x 3 MH55	3
	F881011169	O-ring Ø 76 x 3 MH60	3
	F881011170	O-ring Ø 80 x 3 MH65	3
91	F022300290	Packing support MH45	3
	F022300300	Packing support MH50	3
	F022300310	Packing support MH55	3
	F022300320	Packing support MH60	3
	F022300330	Packing support MH65	3
92	F881011053	O-ring Ø 80 x 2	3
93	F881061017	Scraper MH45	3
	F881061018	Scraper MH50	3
	F881061019	Scraper MH55	3
	F881061021	Scraper MH60	3
	F881061023	Scraper MH65	3
94	F010500290	Anti-extrusion ring	6

Also included:

F1201	Inlet flange, closed
F1299	Inlet flange, open, 3" NPT
680096	Drain valve kit



## 17. TROUBLE SHOOTING



**THE PUMP DOES NOT PRODUCE ANY NOISE:** the pump is not primed and is running dry!

- No water in the inlet line
- The valves are blocked
- The pressure line is closed and does not allow the air to get out the fluid end.

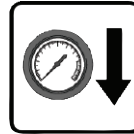

**INSUFFICIENT PUMP PRESSURE:**

- The nozzle is (or has become) too large.
- RPM are less than rated
- Excessive leakage from pressure packings
- Excessive amount of water by-passed by the pressure regulating valve or faulty valve operation.
- Worn out valves.



**THE PUMP KNOCKS:**

- Air suction.
- Insufficient feeding:
  - bends, elbows and fittings along the suction line throttle the amount of water which passed through.
  - too small inlet filter.
  - dirty inlet filter.
  - the feeding pump, where provided is not of the suitable type or provides insufficient pressure or volume.
- The pump is not primed due to insufficient feeding or the delivery line is closed during start up.
- The pump is not primed because some valves are stuck (i.e pump inactivity for long time).
- Jammed or worn out valves.
- Worn out pressure packings.
- The pressure regulating valve does not work properly.
- Clearance in the drive system.
- RPM are higher than rated.

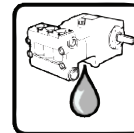

**EXCESSIVE WATER LEAKAGE FROM THE PUMP:**

- Pressure packing are excessively worn out (due to normal wear or excessive cavitation).
- Worn out plungers

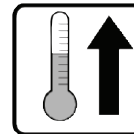

**OVERHEATED PUMP:**

- The direction of rotation is not correct.
- Pump is overloaded (pressure or RPM over the rated values).
- The oil level is too low or the oil is not of a suitable type or fully used
- Water in the oil
- Excessive belt tension or incorrect alignment of the joint (where provided).
- Excessive inclination of the pump during operation.



**THE PUMP DOES NOT DELIVER THE RATED VOLUME:**

- Insufficient feeding (due to the cause listed above).
- RPM are less than rated.
- Excessive amount of water by-passed by the pressure regulating valve.
- Worn out valves
- Excessive leakage from pressure packings

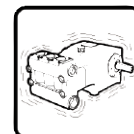

**PIPE VIBRATIONS OR KNOCKING:**

- Air suction.
- The pressure regulating valve does not work properly.
- The by-pass line is undersized.
- Jammed up valves.
- Drive transmission motion is irregular.

**MAINTENANCE LOG****HOURS & DATE**

<b>OIL CHANGE</b>							
<b>GREASE</b>							
<b>PACKING REPLACEMENT</b>							
<b>PLUNGER REPLACEMENT</b>							
<b>VALVE REPLACEMENT</b>							



GP Companies, Inc.  
 1174 Northland Drive  
 Mendota Heights, MN 55120  
 Phone: 651.686.2199 Fax: 800.535.1745  
 www.generalpump.com email: sales@gpcompanies.com

Ref 300019 Rev.C  
 08/07