

FEATURES

- Features patent-pending “high tech” packings:
 - dynamic low-pressure seal retainer
 - superior low-pressure seal
 - innovative intermediate ring
 - superior high-pressure seal
- Ceramic plungers
- Patent-pending inlet/outlet valve cage
- Nickel-plated inlet/outlet valve plugs
- Nickel-plated forged brass manifold with exclusive lifetime warranty
- Designed for touchless carwash systems and multiple gun systems
- Excellent for carpet cleaning and for use in industrial plant systems where hot water is required



Emperor
Pumps That Rule Any Environment

**SPECIFICATIONS**

| Pump Model | HTW3624S |
|---------------------------|--------------------------|
| Maximum Volume | 18.0 GPM |
| Maximum Pressure | 1200 PSI |
| Maximum RPM | 1000 RPM |
| Maximum Inlet Pressure | 125 PSI |
| Minimum Inlet Pressure | 9 ft. water (7.9 in. Hg) |
| Maximum Fluid Temperature | 185°F |
| Bore (in / mm) | 1.417 in. / 36 mm |
| Stroke (in / mm) | .945 in. / 24 mm |
| Oil Capacity | 50.7 oz. |
| Inlet Port Thread | 1"-11 BSP-F |
| Discharge Port Thread | 3/4"-14 BSP-F |
| Shaft Diameter | 1.378 in. / 35 mm |
| Weight | 57 lbs. |
| Dimensions - Nominal | 14" x 11.8" x 8.3" |

Instructions and Recommendations for the Installation of *HT Series Pumps*

The high-temperature pumps of the HT series have been designed for use in applications where the water must be pre-heated, such as in carwash, food and pharmaceutical industries.

Maximum temperature of the water through the pump is 185°F (85°C).

In order to obtain maximum performance in terms of duration of seals and valves, it is necessary to respect a few simple rules, as follows:

1) In order to avoid damage caused by cavitation, the pump must be pressure fed.

The higher the inlet pressure, the longer the life of the wet end of the pump.

When working at 185°F (85°C), the minimum feed pressure - measured directly in the inlet port of the pump when it is working - is 45 psi (3 bar).

The minimum feed pressure according to the different temperatures are:

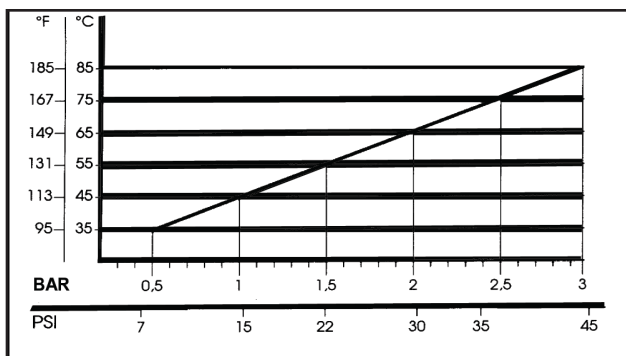

Naturally, if the application allows for feeding the pump with 45 psi (3 bar) even at low temperatures (for example: 115°F/45°C the life of the wet end of the pump will be even longer.

2) The plumbing which feeds the pump must be of a diameter at least equal to the inlet port.

Also, follow the suggestions below:

- a) Make the plumbing as short and straight as possible, preferably in an upward direction to facilitate the expulsion of eventual air bubbles naturally if compatible with the requirements of the system.
- b) It is always useful to put a filter at the inlet with capacity of 4 to 5 times the flow of

the pump, for example for a 4 gpm (15 l/min) pump, put a filter from 16 to 20 gpm (60-75 l/min). The mesh size suitable for this application is 0.016" (.4 mm).

- c) It is extremely important to put a pressure switch on the suction port of the pump, and in any case downstream from the filter, so that it can stop the pump should the feed pressure drop by 20% due to the filter clogging or failure of the feed pump, etc.

3) Change of oil

We recommend the **first oil change after the first 50 hours**, with the **pump stopped** and the **oil still warm**.

This change is not recommended because the oil has lost its properties, but rather to eliminate the impurities that have gotten into the oil during the running-in phase. If these impurities are not removed, but are allowed to remain in the oil, they *may cause premature wear* to the moving parts and the oil seals. **After this initial change, the oil can then be changed every three months or 300 hours of operation thereafter.**

Please note: If the pump works in conditions with high humidity and with sharp temperature changes, it is possible that condensation will appear inside the crankcase, which mixing with the oil can change its properties. This is easy to see because the oil changes to a white, milky color.

If the pump does not have excessive water leaking from the packings, and the oil becomes milky, the oil has to be changed more frequently. The percentage of water in the oil must not exceed 20%.

Use oil per the following chart:

| CHART OF COMPATIBLE OILS SAE15W40 | |
|-----------------------------------|------------------|
| GENERAL PUMP | SERIES 100 |
| BP | VISCO 2000 |
| CASTROL | CWX |
| MOBIL | SUPER |
| SHELL | HELIX SUPER |
| TOTAL | QUARTZ 4000-5000 |

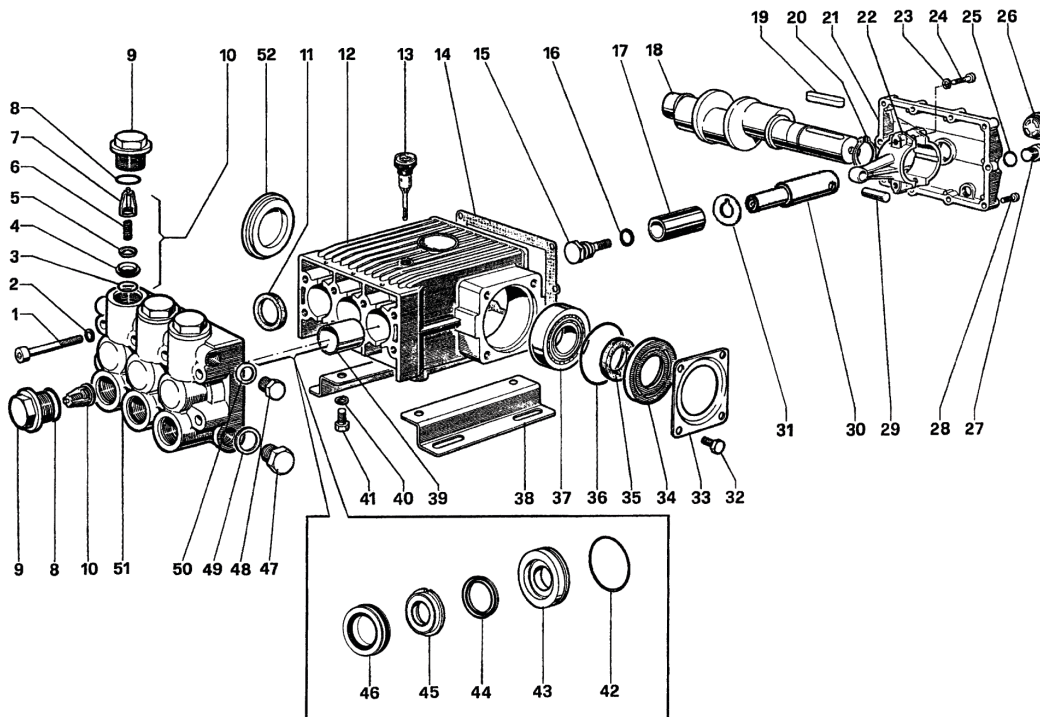

PARTS LIST

| ITEM | PART NO. | DESCRIPTION | QTY | ITEM | PART NO. | DESCRIPTION | QTY | ITEM | PART NO. | DESCRIPTION | QTY |
|------|----------|--------------------------|-----|------|----------|-----------------------|-----|------|----------|-------------------------------|-----|
| 1. | 99381000 | Head Bolt, M10 | 8 | 19. | 91496900 | Key | 1 | 37. | 91848200 | Bearing, Cylindrical Roller | 2 |
| 2. | 96710400 | Washer, M10 | 8 | 20. | 90069500 | Circlip | 1 | 38. | 47200074 | Pump Rail | 2 |
| 3. | 90405900 | O-ring | 6 | 21. | 69160022 | Crankcase Cover, Rear | 1 | 39. | 90916200 | Guide Bushing | 3 |
| 4. | 36201166 | Valve Seat | 6 | 22. | 69030401 | Connecting Rod | 3 | 40. | 96710600 | Washer, M10.2 | 4 |
| 5. | 36201076 | Valve Poppet | 6 | 23. | 96701400 | Lock Washer, M8.4 | 6 | 41. | 99364400 | Screw, M10 | 4 |
| 6. | 94745000 | Valve Spring | 6 | 24. | 99309900 | Screw, M8 | 6 | 42. | 90388500 | O-ring | 3 |
| 7. | 36200951 | Valve Guide | 6 | 25. | 90383300 | O-ring | 1 | 43. | 69080570 | Seal Retainer, 36mm | 3 |
| 8. | 90406500 | O-ring | 6 | 26. | 97596800 | Oil Level Indicator | 1 | 44. | 90240000 | L.P. Seal, 36mm | 3 |
| 9. | 98242100 | Valve Cap, Nickel-plated | 6 | 27. | 98210000 | Plug, 3/8" | 1 | 45. | 69217170 | Intermediate Ring, 36mm | 3 |
| 10. | 36706501 | Valve, Complete | 6 | 28. | 99186700 | Screw, M6 | 9 | 46. | 90241000 | H.P. Seal, 36mm | 3 |
| 11. | 90165600 | Plunger Rod Oil Seal | 3 | 29. | 97739800 | Wrist Pin | 3 | 47. | 98232600 | Plug, Nickel-plated, G1" | 1 |
| 12. | 69010022 | Crankcase | 1 | 30. | 69050022 | Plunger Guide | 3 | 48. | 98226900 | Plug, Nickel-plated, G3/4" | 1 |
| 13. | 98210600 | Dipstick, Vented | 1 | 31. | 96756500 | Flinger Washer | 3 | 49. | 96787000 | Washer | 1 |
| 14. | 69211984 | Gasket | 1 | 32. | 99363600 | Screw, M10 | 8 | 50. | 96770000 | Washer | 1 |
| 15. | 69219666 | Plunger Screw | 3 | 33. | 68150074 | Crankcase Cover | 2 | 51. | 69121941 | Manifold, Nickel-plated, 36mm | 1 |
| 16. | 90385900 | O-ring | 3 | 34. | 69211551 | Spacer | 1 | 52. | 69211651 | Spacer | 1 |
| 17. | 69040009 | Plunger, 36mm | 3 | 35. | 90167200 | Crankshaft Oil Seal | 1 | | | | |
| 18. | 69020535 | Crankshaft | 1 | 36. | 90413100 | O-ring | 2 | | | | |

REPAIR KITS

| KIT NO. | K32 | K37 | K43 | K212 | K213 |
|-------------------------------|-----|-----|--------------------|--------|--------------------|
| ITEM NO'S INCLUDED IN KIT | 35 | 11 | 3, 4, 5, 6, 7 (10) | 44, 46 | 42, 43, 44, 45, 46 |
| NUMBER OF ASSY'S IN KIT | 2 | 3 | 6 | 3 | 1 |
| NO. OF CYLINDERS KIT SERVICES | - | 3 | 3 | 3 | 1 |

TORQUE SPECS*

| Position | Ft.-Lbs. | Nm. |
|----------|----------|------|
| 1 | 29.5 | 40 |
| 9 | 111 | 150 |
| 15** | 29.4 | 21.7 |
| 24 | 14.7 | 10.8 |
| 26 | 13.2 | 9.7 |
| 27 | 29.4 | 21.7 |
| 28 | 7.3 | 5.4 |
| 32 | 29.4 | 21.7 |
| 41 | 29.4 | 21.7 |
| 47 | 73.7 | 54.4 |
| 48 | 51.5 | 38 |

*Decrease torque by 20% if threads are lubricated.

**Use Loctite 542

DIMENSIONS

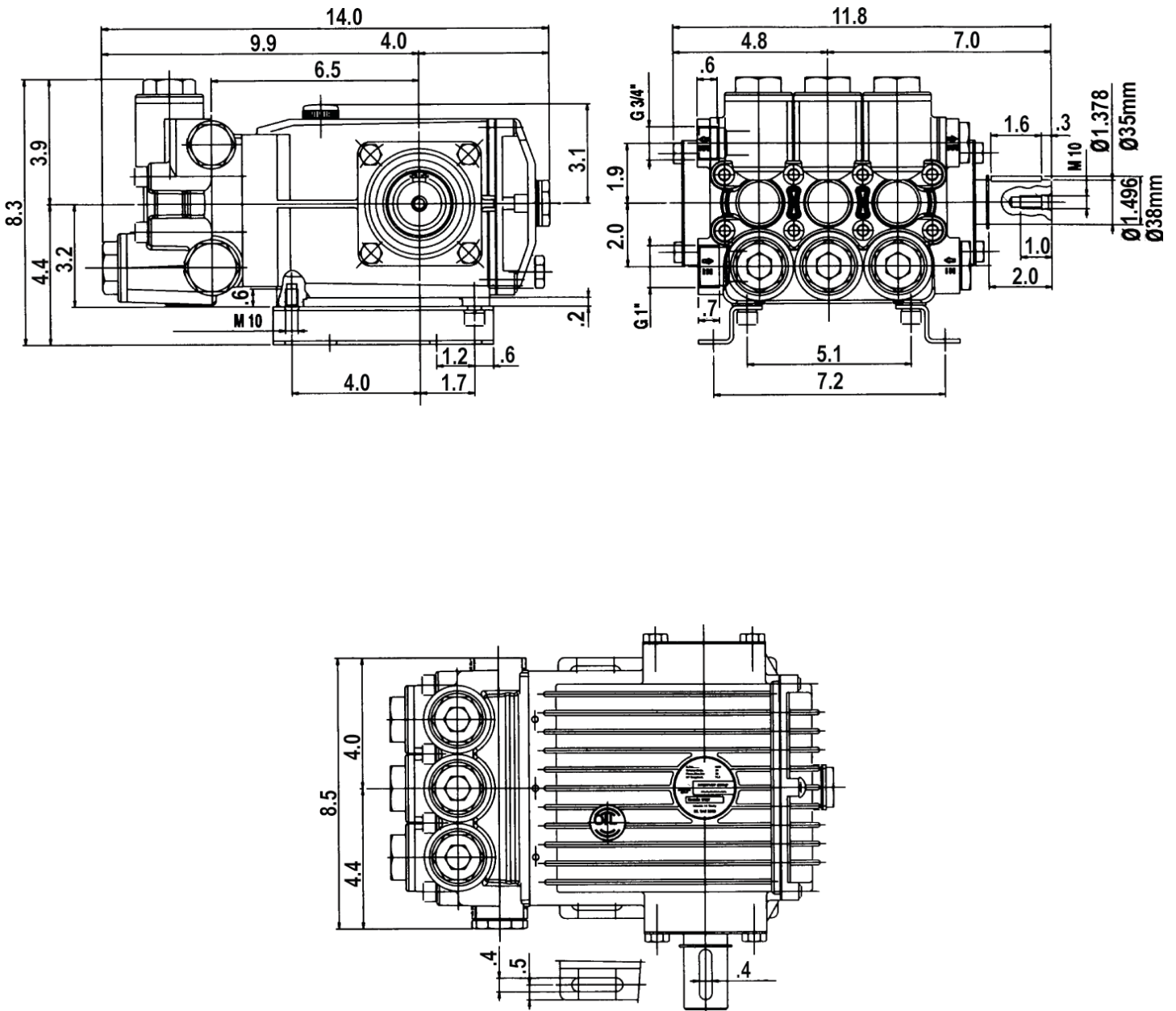

Ref 300549 Rev.A
05-05