

FEATURES

- Features patent-pending “high tech” packings:
 - dynamic low-pressure seal retainer
 - superior low-pressure seal
 - innovative intermediate ring
 - superior high-pressure seal
- Ceramic plungers
- Patent-pending inlet/outlet valve cage
- Nickel-plated forged brass manifold with an exclusive lifetime warranty
- Heavy-duty tapered roller bearings
- Specifically designed to handle rigorous duty cycles, high temperatures and chemicals
- Ideal for use in car wash and other high pressure cleaning applications



Emperor
Pumps That Rule Any Environment

**SPECIFICATIONS**

Pump Model	HTCK3623S
Maximum Volume	21.0/25.0
Maximum Pressure	1500/1300
Maximum RPM	1150/1350
Maximum Inlet Pressure	125 PSI
Minimum Inlet Pressure	3 ft. water (2.6 in. Hg)
Maximum Fluid Temperature	185°F
Bore (in / mm)	1.4 in./36mm
Stroke (in / mm)	.9 in./ 23 mm
Oil Capacity	64.2 oz.
Inlet Port Thread	1" NPT-F
Discharge Port Thread	1/2" NPT-F
Shaft Diameter	1.2 in./30 mm
Weight	79.6 lbs.
Dimensions - Nominal	15.3" x 13.4" x 7.7"



General Pump is a
Member of
The Interpump Group



Instructions and Recommendations for the Installation of *HT Series Pumps*

The high-temperature pumps of the HT series have been designed for use in applications where the water must be pre-heated, such as in carwash, food and pharmaceutical industries.

Maximum temperature of the water through the pump is 185°F (85°C).

In order to obtain maximum performance in terms of duration of seals and valves, it is necessary to respect a few simple rules, as follows:

1) In order to avoid damage caused by cavitation, the pump must be pressure fed.

The higher the inlet pressure, the longer the life of the wet end of the pump.

When working at 185°F (85°C), the minimum feed pressure - measured directly in the inlet port of the pump when it is working - is 45 psi (3 bar).

The minimum feed pressure according to the different temperatures are:

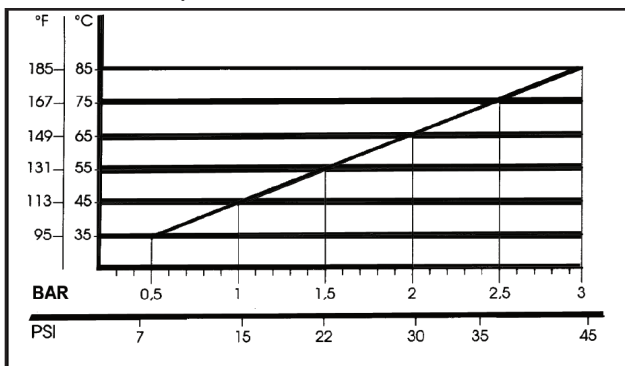

Naturally, if the application allows for feeding the pump with 45 psi (3 bar) even at low temperatures (for example: 115°F/45°C the life of the wet end of the pump will be even longer.

2) The plumbing which feeds the pump must be of a diameter at least equal to the inlet port.

Also, follow the suggestions below:

a) Make the plumbing as short and straight as possible, preferably in an upward direction to facilitate the expulsion of eventual air bubbles naturally if compatible with the requirements of the system.

b) It is always useful to put a filter at the inlet with capacity of 4 to 5 times the flow of

the pump, for example for a 4 gpm (15 l/min) pump, put a filter from 16 to 20 gpm (60-75 l/min). The mesh size suitable for this application is 0.016" (.4 mm).

c) It is extremely important to put a pressure switch on the suction port of the pump, and in any case downstream from the filter, so that it can stop the pump should the feed pressure drop by 20% due to the filter clogging or failure of the feed pump, etc.

3) Change of oil

We recommend the **first oil change after the first 50 hours**, with the **pump stopped** and the **oil still warm**.

This change is not recommended because the oil has lost its properties, but rather to eliminate the impurities that have gotten into the oil during the running-in phase. If these impurities are not removed, but are allowed to remain in the oil, they may cause premature wear to the moving parts and the oil seals. **After this initial change, the oil can then be changed every three months or 300 hours of operation thereafter.**

Please note: If the pump works in conditions with high humidity and with sharp temperature changes, it is possible that condensation will appear inside the crankcase, which mixing with the oil can change its properties. This is easy to see because the oil changes to a white, milky color.

If the pump does not have excessive water leaking from the packings, and the oil becomes milky, the oil has to be changed more frequently. The percentage of water in the oil must not exceed 20%.

Use oil per the following chart:

CHART OF COMPATIBLE OILS SAE15W40	
GENERAL PUMP	SERIES 100
BP	VISCO 2000
CASTROL	CWX
MOBIL	SUPER
SHELL	HELIX SUPER
TOTAL	QUARTZ 4000-5000

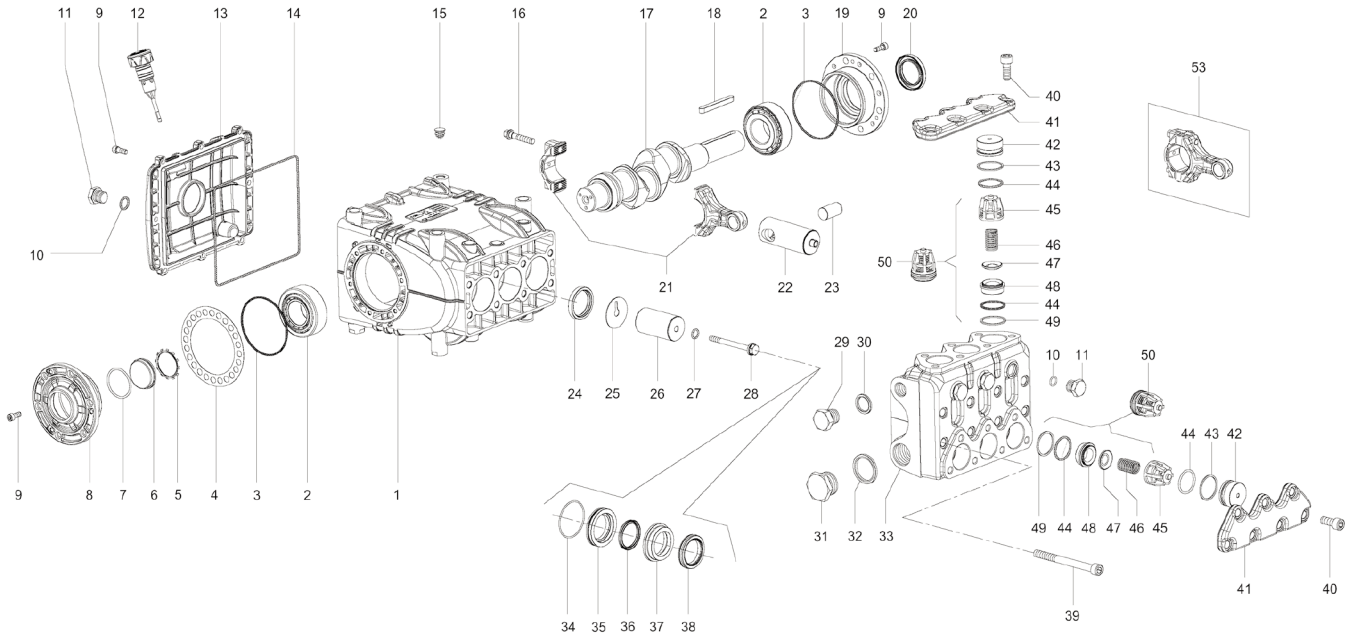

PARTS LIST

ITEM	PART NO.	DESCRIPTION	QTY	ITEM	PART NO.	DESCRIPTION	QTY	ITEM	PART NO.	DESCRIPTION	QTY
1.	70010022	Crankcase	1	18.	91490000	Key	1	35.	70080570	Seal Retainer, 36 mm	3
2.	91847700	Bearing, Tapered Roller	2	19.	70150022	Crankcase Cover, Open	1	36.	90240000	L.P Seal, 36 mm	3
3.	90391500	O-ring	2	20.	90166800	Crankshaft Oil Seal	1	37.	70216570	Intermediate Ring, 36 mm 3	3
4.	70220081	Shim	1	21.	70030043	Connecting Rod	3	38.	90241000	H.P. Seal, 36 mm	3
	70220381	Shim	1	22.	70050015	Plunger Guide	6	39.	99381600	Screw, M10 x 110	8
5.	90075600	Retainer	1	23.	97742000	Wrist Pin	3	40.	99367100	Screw, M10 x 25	14
6.	70211801	Oil Level Indicator	1	24.	90167700	Plunger Rod Oil Seal	3	41.	70210036	Valve Cover	2
7.	90387700	O-ring	1	25.	96709900	Flinger Washer	3	42.	70211670	Plug	6
8.	70150122	Side Cover, Sight Glass	1	26.	70040509	Plunger, 36 mm	3	43.	90518000	Anti-extrusion Ring	6
9.	99185400	Screw, M6 x 16	20	27.	90367100	O-ring	3	44.	90386500	O-ring	12
10.	90383300	O-ring	4	28.	70219566	Plunger Bolt	3	45.	36204751	Valve Guide	6
11.	98209900	Plug, 3/8" G Nickel-plated	4	29.	98218200	Plug, 1/2" G, Nickel-plated	1	46.	94745000	Valve Spring	6
12.	98211500	Oil Dipstick	1	30.	93197200	Washer	1	47.	36201076	Valve Poppet	6
13.	70160022	Crankcase Cover, Rear	1	31.	98232600	Plug, 1" G, Nickel-plated	1	48.	36204866	Valve Seat	6
14.	90394400	O-ring	1	32.	93198500	Washer	1	49.	90517800	Anti-extrusion Ring	6
15.	98200500	Rubber Plug	7	33.	70122341	Manifold, Nickel-plated, 36 mm, G	1	50.	36714301	Valve Assy., Complete	6
16.	99312300	Screw	6		70122441	Manifold, Nickel-plated, 36 mm, NPT	1	53.	70030001	Connecting Rod Assy.	3
17.	70020035	Crankshaft	1	34.	90363600	O-ring	3				

REPAIR KITS

KIT NO.	K2030	K212	K2032
ITEM NO'S INCLUDED IN KIT	44, 45, 46, 47, 48, 49 (50)	36, 38	34, 35, 36, 37, 38
NUMBER OF ASSY'S IN KIT	6	3	1
NO. OF CYLINDERS KIT SERVICES	3	3	1

TORQUE SPECS*

Position	Ft.-Lbs.	Nm.
9	7.4	10
11	29.5	40
16	28.0	38
28**	14.7	20
29	88.5	120
31	73.7	100
39	29.5	40
40	59.0	80
52	16.2	22

*Decrease torque by 20% if threads are lubricated.

**Use Loctite 542.

DIMENSIONS

