

### FEATURES

- 316 stainless steel fluid end
- 300 series stainless steel fasteners
- Parallel inlet and outlet valve design for easy maintenance and improved efficiency
- Corrosion-resistant valve and packing design
- Innovative, wear-resistant high- and low-pressure seals for ultimate life
- Dual inlet and outlet porting for flexible plumbing options
- Anodized aluminum crankcase for superior protection
- Double ball bearing design for ultimate crankshaft support
- Left-handed crankshaft orientation also available



### SPECIFICATIONS

Pump Model	WM4215S
Maximum Volume	4.2 GPM
Max. Discharge Pressure	1500 PSI
Maximum Pump Speed	1750 RPM
Rated Inlet Pressure	-5 - 50 PSI
Bore	.787 in. / 20 mm
Stroke	.492 in. / 12.5 mm
Crankcase Oil Capacity	12.0 oz.
Maximum Fluid Temp.	140°F
Inlet Port Thread	1/2 NPT-F
Discharge Port Thread	3/8 NPT-F
Shaft Diameter.	24 mm
Weight	13.5 lbs.
Dimensions	8.7" x 7.8" x 5.3"

### DIMENSIONAL DRAWING

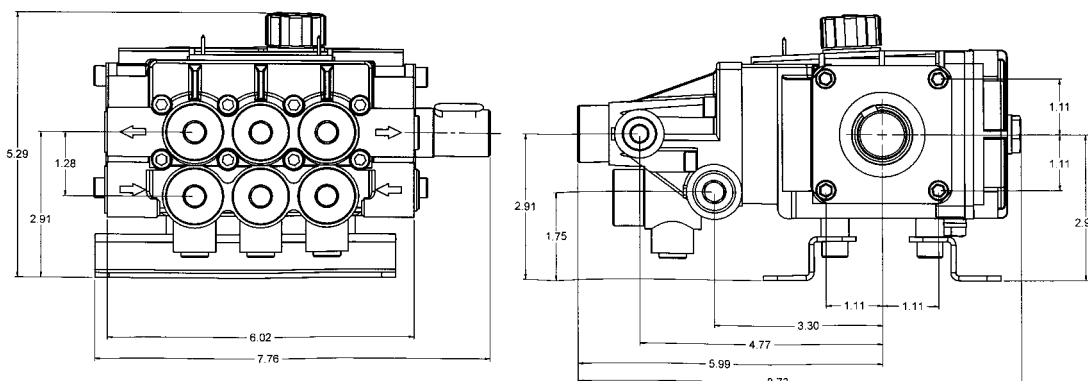

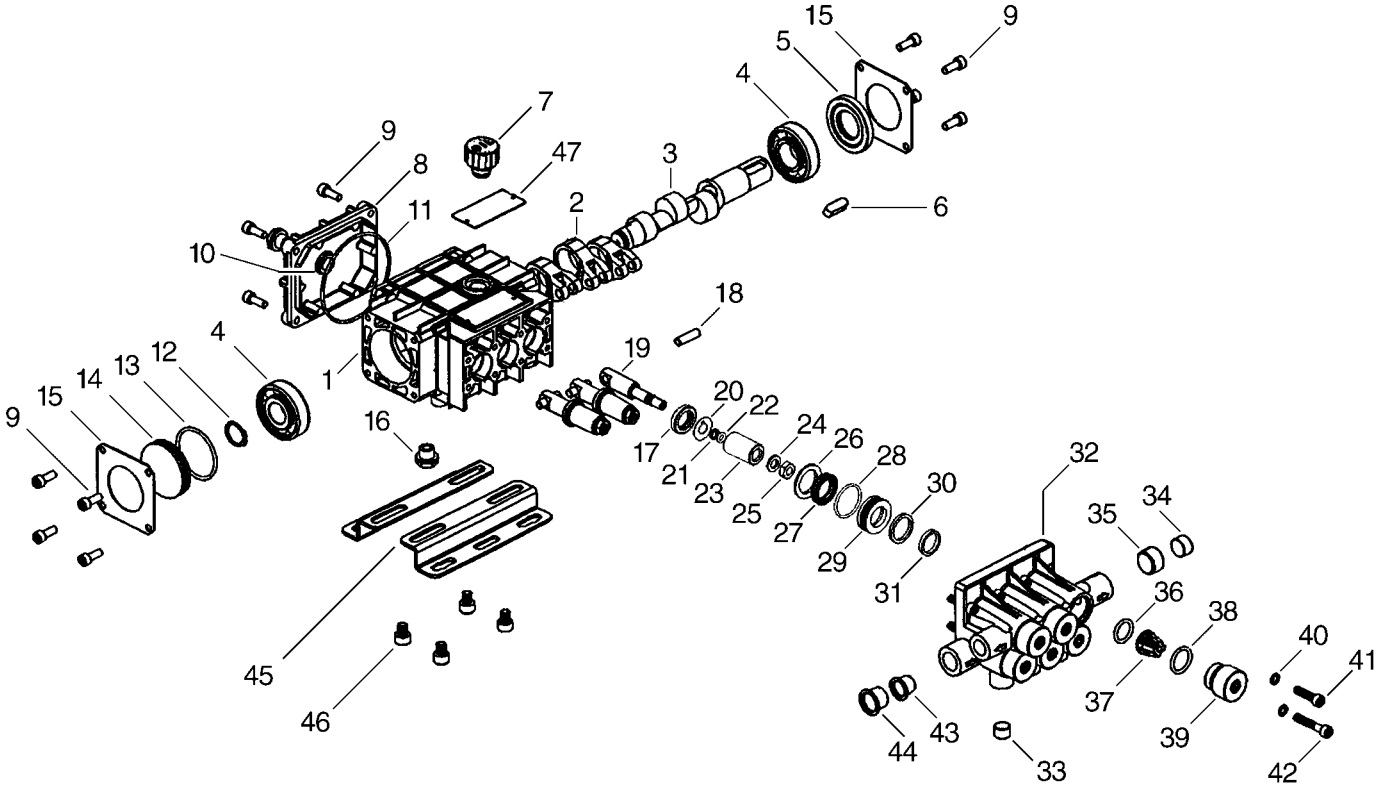

### PARTS LIST

ITEM	PART NO.	DESCRIPTION	KIT NO.	QTY.	ITEM	PART NO.	DESCRIPTION	KIT NO.	QTY.	ITEM	PART NO.	DESCRIPTION	KIT NO.	QTY.
1-29.	195022	Crankcase Case Assembly		1	16.	650031	Oil drain plug		1	32.	520055	Manifold		1
1.	650000	Crankcase		1	17.	710002	Oil seal plunger		3	33.	520061	1/4 NPT plug		3
2.	650024	Connecting rod		3	18.	650023	Wrist pin		3	34.	520063	3/8 NPT plug		1
3.	650042	Crankshaft		1	19.	650020	Plunger rod		3	35.	520062	1/2 NPT plug		1
4.	147004	Bearing		2	20.	650021	Slinger		3	36.	701115	O-ring valve spacer	WM01	6
5.	710022	Seal, Oil, Crankshaft		1	21.	660024	Anti-extrusion ring		3	37.	103042	Valve	WM01	6
6.	640059	Key		1	22.	701501	O-ring plunger		3	38.	701002	O-ring valve cap	WM01	6
7.	650032	Oil Cap		1	23.	650018	Plunger, 18mm		3	39.	520057	Valve plug		6
8.	650026	Rear cover		1	24.	203401	Washer, plunger rod		3	40.	203510	Washer, ribbed lock		8
9.	200003	Screw, SHCS 20mm		12	25.	203000	Nut, plunger rod		3	41.	200025	Screw, SHCS, 25mm		4
10.	650025	Sight Glass		1	26.	660053	Seal retainer	WM02	3	42.	200026	Screw, SHCS, 35mm		4
11.	701610	O-Ring, rear cover		1	27.	710012	Low pressure seal	WM02	3	43.	145029	Plug, cap #7		1
12.	650043	Snap ring		1	28.	710023	O-ring seal case	WM02	3	44.	145030	Plug, cap #9		1
13.	701133	O-ring, oil seal retainer, side cover		1	29.	660054	Seal case	WM02	3	45.	540049	Rail		2
14.	650010	Side cover		1	30.	710011	Square ring, high press. seal	WM02	3	46.	200047	Screws, M8x1.25X10mm		4
15.	650009	Side plate		2	31.	710010	Glyd ring, high press. seal	WM02	3	47.	604040	Label		1

### REPAIR KITS

KIT NO.	WM02	WM01
ITEM NO.s INCLUDED IN KIT	26, 27, 28, 29, 30, 31 *	36, 37, 38
NUMBER OF ASSEMBLIES IN KIT	3	6

\*Includes 660062 and 660063 seal installation tools.

### TORQUE SPECS

Position	Ft.-lbs.
9	7.3
25	7.3
39	3.5
41	8.0
42	8.0