

# TX Series "63"

*Triplex Plunger Pump, 1-18" Hollow Shaft*

## FEATURES

- Flanged for direct couple to electric motor (NEMA 184TC)
- Set screw for key way
- Oversized bearings
- Longer life low and high pressure seals
- Forged brass manifold with exclusive lifetime warranty

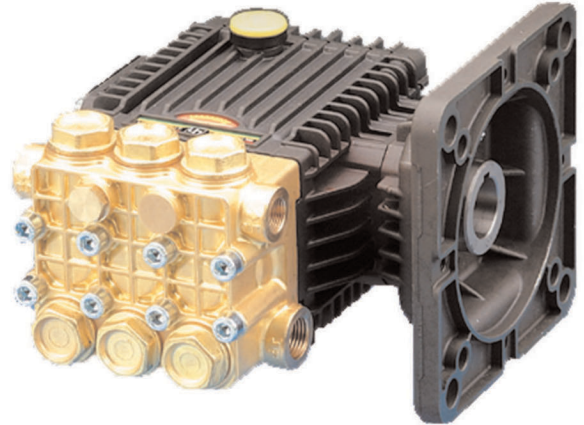

## SPECIFICATIONS

Pump Model	TX1810E179	TX1812E179	TX1512E179	TX1510E349
Maximum Volume	3.2 GPM	3.8 GPM	2.6 GPM	4.0 GPM
Max. Discharge Pressure	2000 PSI		3000 PSI	
Horsepower	4.4 EBHP	5.2 EBHP	5.3 EBHP	8.2 EBHP
Maximum Pump Speed	1750 RPM			3400 RPM
Maximum Inlet Pressure	125 PSI			
Maximum Inlet Vacuum	3 Ft. Water (2.6 in. Hg)			Flooded
Bore	.708 in. / 18 mm		.591 in. / 15 mm	
Stroke	.394 in/10 mm	.472 in/12 mm	.472 in/12 mm	.394 in/ 10 mm
Crankcase Oil Capacity	14.0 oz.			
Max Fluid Temperature	165° F			
Inlet Port Thread	1/2-14 BSPP-F			
Discharge Port Thread	3/8-19 BSPP-F			
Shaft Diameter	1.125 in. / 28.5 mm			
Weight	18 lbs.			
Dimensions	8.6 x 7.9 x 5.7 in.			

## DIMENSIONAL DRAWING

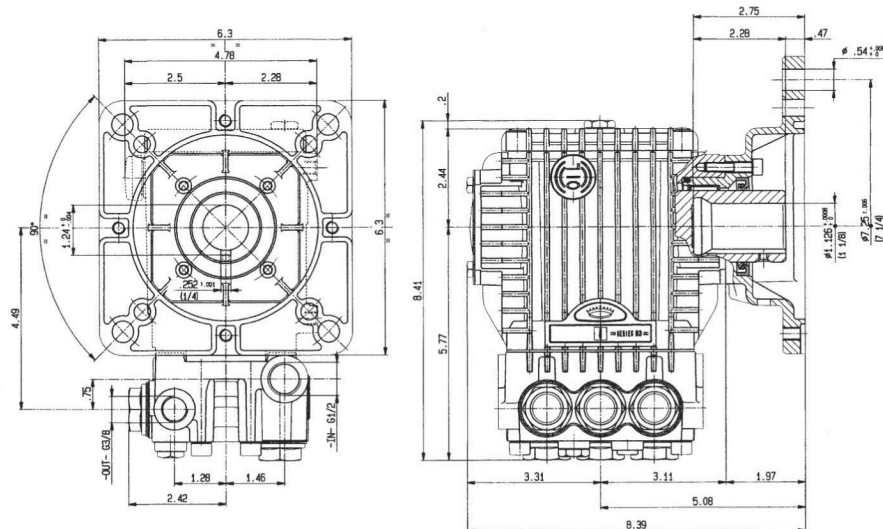

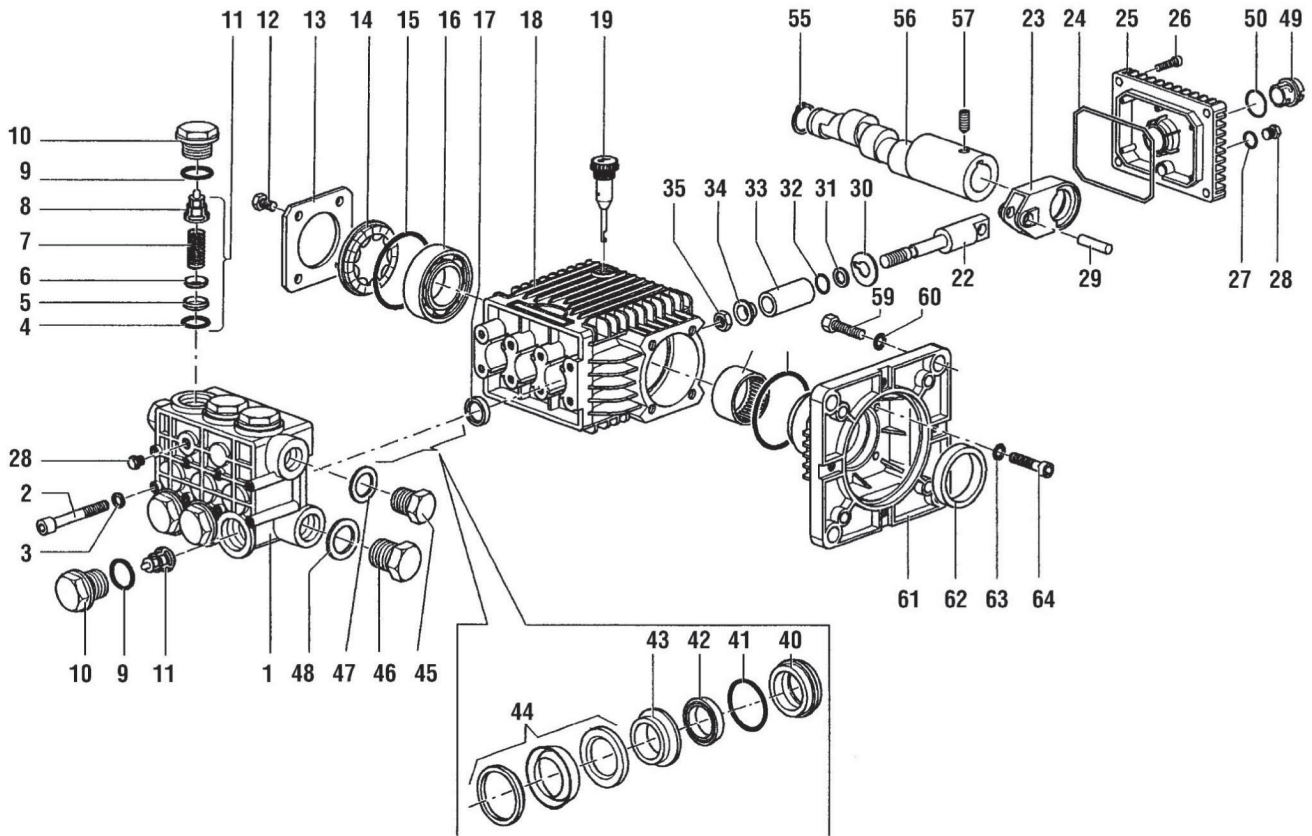

## PARTS LIST

ITEM	PART NO.	DESCRIPTION	KIT NO.	QTY.	ITEM	PART NO.	DESCRIPTION	KIT NO.	QTY.	ITEM	PART NO.	DESCRIPTION	KIT NO.	QTY.
1.	63120041	Manifold, 15 mm		1	22.	63050066	Plunger Guide		3	43.	63216070	Int Ring, 15mm	164,166	3
2.	99319200	Screw, M8 x 65		8	23.	63030022	Connecting Rod		3		63216170	Int Ring, 18mm	165,167	3
3.	96701400	Lockwasher, M8.4		8	24.	90392000	O-ring, Cover		1	44.	90261200	Packing Assy, 15mm	160,166	3
4.	90384100	O-ring	123	6	25.	63160022	Rear Crankcase Cover		1		90265400	Packing Assy, 18mm	161,167	3
5.	36200366	Valve Seat	123	6	26.	99183700	Screw, M6 x 14		4	45.	98210000	Plug, 3/8" G		1
6.	36200176	Valve Plate	123	6	27.	701013	O-ring		1	46.	98217600	Plug, 1/2" G		1
7.	94737600	Spring	123	6	28.	98204100	Plug, 1/4" G		2	47.	96738000	Washer, M17.5		1
8.	36202551	Valve Cage	123	6	29.	97733500	Connecting Rod Pin		3	48.	96751400	Washer, M21.5		1
9.	90384700	O-ring	124	6	30.	96707500	Flinger Washer		3	49.	63210051	Oil Level Indicator		1
10.	98222600	Valve Cap	124	6	31.	660024	Anti-extrusion Ring		3	50.	90405100	O-ring		1
11.	36711501	Valve Assembly	123	6	32.	701009	O-ring		3	55.	90063500	Retaining ring		1
12.	99180700	Screw, M6 x 10		8	33.	52040009	Ceramic Plunger, 15mm		3		63023265	Crankshaft, 10mm		1
13.	50150074	Bearing Cover		1	34.	44211570	Bushing		3		63023665	Crankshaft, 12mm		1
14.	44211801	Oil Level Indicator		1	35.	92221600	Nut, M8		3	57.	99179000	Set screw, M6 x 6		1
15.	90409700	O-ring		2		63080070	Seal Retn'r, 15mm	162,166	3	58.	91856800	Roller bearing		1
16.	91832900	Ball Bearing		1	40.	63080170	Seal Retn'r, 18mm	163,167	1	59.	99460000	Screw		4
17.	90159500	Oil Seal	159	3	41.	90360800	O-ring	166,167	3	60.	96719500	Washer		4
18.	63010022	Crankcase		1	42.	90260800	Seal, LP, 15mm	160,166	3	61.	10050422	Flange, electric 184TC		1
19.	98210300	Oil Dip Stick		1		90265000	Seal, LP, 18mm	161,167	3	62.	90169000	Oil seal		1
21.	91489200	Key		1						63.	96693800	Lockwasher, M6.4		4
										64.	99191200	Screw, M6 x 30		4

## REPAIR KITS

KIT NO.	123	124	159	160 or 161 (15mm) (18mm)	162 or 163 (15mm) (18mm)	164 or 165 (15mm) (18mm)	166 or 167 (15mm) (18mm)
ITEM NO.s INCLUDED IN KIT	4, 5, 6, 7, 8 (11)	9, 10	17	42, 44	40	43	40, 41, 42, 43, 44
NUMBER OF ASSEMBLIES IN KIT	6	6	3	3	3	3	1
NUMBER OF CYLINDERS KIT WILL SERVICE	3	3	3	3	3	3	1

## TORQUE SPECS\*

Pos.	Ft.-lbs.	N-M
2	14.7	20
10	73.7	100
12	7.3	10
26	7.3	10
28	14.7	20
35	11.0	15
45	29.4	40
46	29.4	40
59	14.7	20
64	7.3	10

\*Decrease torque by 20% if threads are lubricated.