

FEATURES

- Extended-life design for light commercial duty use
- Heavy duty die-cast aluminum housing
- Integrated flow sensing unloader
- Integrated mounting manifold for efficient power transmission and heat dissipation
- Triplex plunger design for smooth operation
- Fixed chemical injector
- Forged brass or aluminum manifold

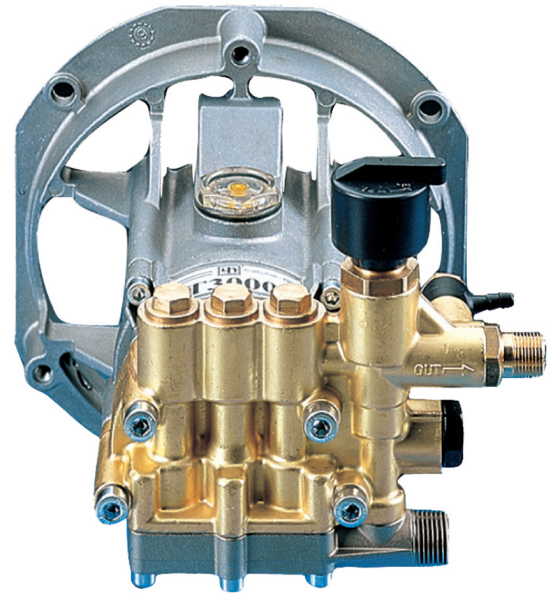

SPECIFICATIONS

Pump Model	TV2020G	TV2016G*	TV2520G	TV2516G*	TV3020G	TV3016G*	TV3520G	TV3516G*
Maximum Volume	2.0 GPM		2.5 GPM		3.0 GPM		3.5 GPM	
Maximum Discharge Pressure	2000 PSI	1600 PSI	2000 PSI	1600 PSI	2000 PSI	1600 PSI	2000 PSI	1600 PSI
Maximum Pump Speed	3600 RPM							
Inlet Pressure	0–100 PSI							
Bore	.591 in. / 15 mm							
Stroke	.191 in. / 4.86 mm		.218 in. / 5.53 mm		.254 in. / 6.46 mm		.307 in. / 7.8 mm	
Crankcase Oil Capacity	6.75 oz.							
Maximum Fluid Temperature	140°F							
Inlet Port Thread	1/2"-14 BSPP-M							
Discharge Port Thread	3/8"-19 BSPP-M							
Shaft Diameter	7/8"							
Weight	9.25 lbs.							
Dimensions	8.35" x 8.27" x 7.22"							

*Aluminum manifold

DIMENSIONAL DRAWING

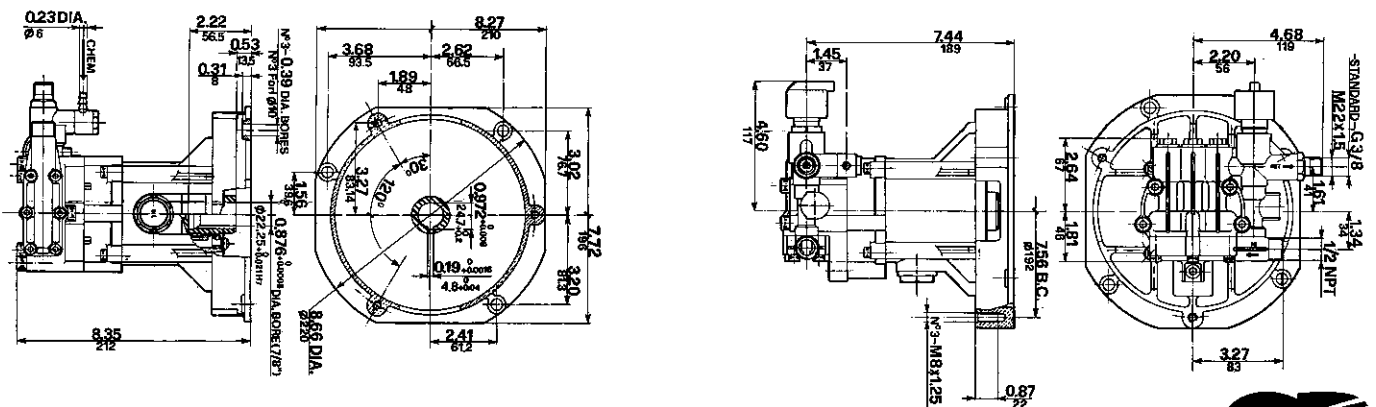

PARTS LIST

Pos. Code	Description	Kit	Qty.
1.	50.1500.74 Crankcase Cover		1
*2.	90.1674.00 Oil Seal, 1.378 ID x 2.44 OD x .393		1
3.	90.0695.00 Snap Ring, Ø1.378		1
4.	57.0100.22 Crankcase		1
5.	57.0200.55 Crankshaft, 7/8"		1
6.	91.8455.00 Needle Bearing		1
7.	91.8347.00 Thrust Bearing		2
8.	57.2111.22 Cam Plate (TV3016G)		1
	57.2107.22 Cam Plate (TV3516G)		1
9.	99.3068.00 Screw, M8 x 25		1
10.	54.0401.01 Piston Assembly, 15mm		3
11.	94.7660.00 Spring, 2.205 x 1.30		1
12.	90.3917.00 O-Ring, 3.487 ID x .104		1
13.	57.2104.22 Piston Guide Body		1
14.	90.1567.00 Oil Seal, Plunger	136	3
15.	57.2100.70 Plug, Ø10mm		1
16.	90.3814.00 O-Ring, .206 ID x .104 CS		1
17.	90.3835.00 O-Ring, .594 ID x .104 CS	118, 119	6
18.	90.3604.00 O-Ring, .989 ID x .070 CS	118, 119	3
19.	51.0802.70 Packing Retainer, Ø15mm	118	3
20.	90.5089.00 Anti-Extrusion Ring	118, 119	3
21.	90.3600.00 O-Ring, .865 ID x .070 CS	118, 119	3
22.	96.7360.00 Washer, .977 x .650 x .040	118, 119	3
23.	57.1201.22 Manifold		1
24.	90.3589.00 O-Ring, .070 x 489	134	6
25.	36.7116.01 Valve Assembly	134	(6)
26.	90.3593.00 O-Ring, .070 x .615	133	6
27.	98.2135.00 Valve Cap, M18 x 1.5 x 10	133	3
28.	36.3247.70 Control Piston	190337	1
29.	90.2585.00 Seal	190337	1
30.	90.3578.00 O-Ring, .302 ID x .070 CS	190337	1
31.	90.5033.00 Anti-Extrusion Ring	190337	1
32.	36.3192.70 Regulating Screw	190337	1
33.	90.3847.00 O-Ring, .797 ID x .104 CS	190337	1
34.	36.3246.70 Bushing Guide, M24	190337	1
35.	90.3833.00 O-Ring, .104 x .550 ID x .104 CS	190337	3
36.	36.3191.51 Knob, Adjustment		1
37.	94.8220.00 Conical Spring, Ø.202/.328 x .472 LG	190337	1
38.	36.3195.51 Spacer	190337	1
39.	36.3197.66 Seat, Valve	190337	1
40.	90.3823.00 O-Ring, .391 ID x .104 CS	190337	3
41.	36.3196.66 Valve	190337	1
42.	99.3210.00 Screw, M8 x 70		4
43.	99.3069.00 Screw, M8 x 25		1
44.	10.0437.66 1.6 mm Orifice, TH2.0 GPM		1
	10.0307.66 1.8 mm Orifice, TH2.5 GPM		1
	10.0151.66 2.0 mm Orifice, TH3.0 GPM		1
	10.0076.66 2.2 mm Orifice, TH3.5 GPM		1
45.	10.0078.70 Nipple, 3/8"		0
	10.0147.70 Nipple, M22 x 1.5		1
46.	98.2090.00 Plug, 3/8" BSPP-M, Plastic, PTP Port		1
47.	57.1400.22 Inlet Manifold		10
48.	99.1914.00 Screw, M6 x 30		1
49.	98.2057.00 Plug, M14 x 1.5 x 9mm		1
50.	97.5968.00 Oil Level Sight Glass, 3/4" BSPP		1
51.	99.1542.00 Screw, M5 x 12		4
60.	36.2563.70 Injector Housing		1
61.	90.3585.00 O-Ring, .426 ID x .070 CS		1
62.	36.2604.51 Hose Barb		1
63.	90.3572.00 O-Ring, .208 ID x .070 CS		1
64.	97.4782.00 Ball, 7/32"		1
65.	94.8217.00 Spring, Conical, Ø.169/.287 x .433 LG		1
66.	90.3582.00 O-Ring, .365 ID x .070 CS		1

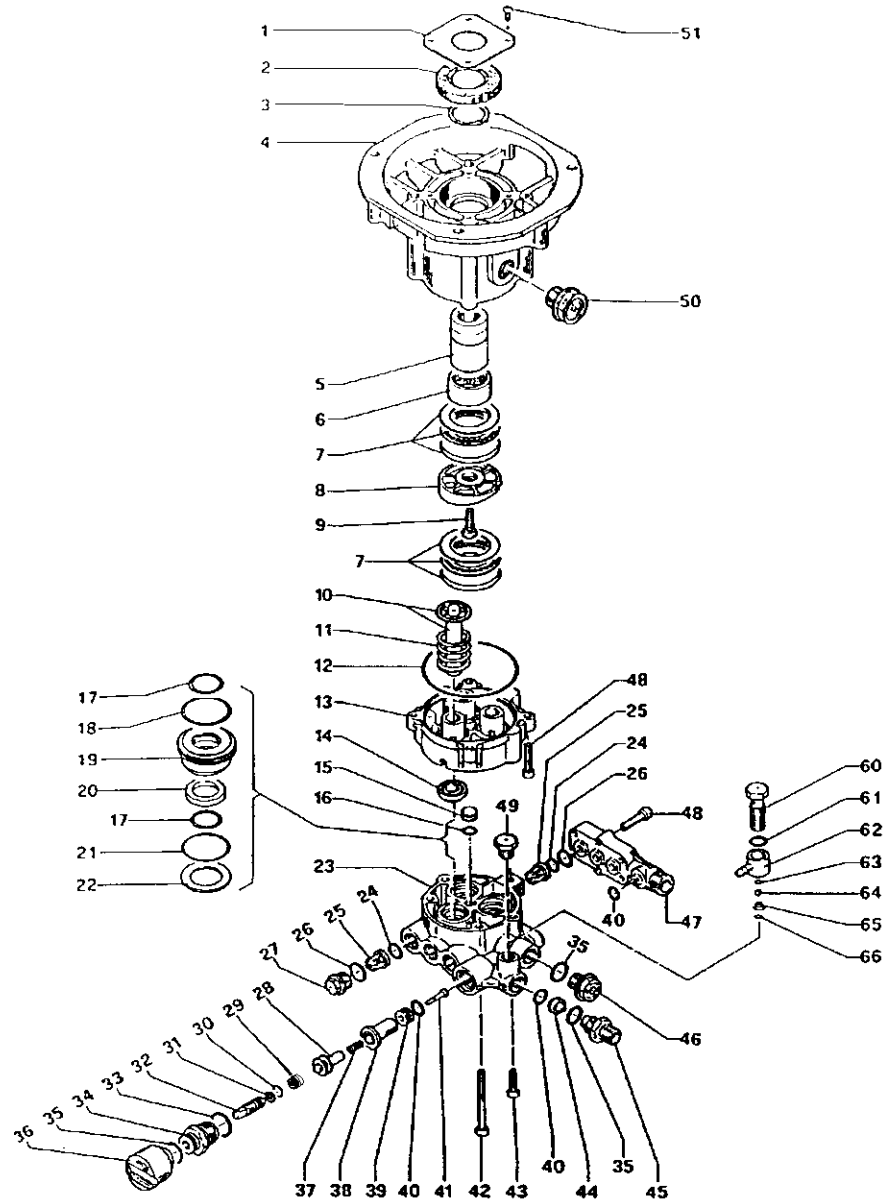

***Install Item No. 2 – "Oil Seal" – upside down to allow venting.**

REPAIR KITS

KIT NO.	118	119	133	134	136	190337
ITEM NO'S INCLUDED IN KIT	17, 18, 20, 21, 22	17, 18, 19, 20, 21, 22	26, 27	24, 25	14	28, 29, 30, 31, 32, 33, 34, 35, 37, 38, 39, 40, 41
NUMBER OF ASSEMBLIES IN KIT	3	1	4	6	3	1

TORQUE SPECS*

Position	Ft.-lbs.
9	36.8
27	22
34	3.7
41	0.74
42	1.5
43	14.7
45	29.4
46	5.1
48	7.4
49	14.7
51	7.4
60	14.7

*Decrease torque by 20% if threads are lubricated.

