

TT Series 51, EBF

Triplex Plunger Pumps

FEATURES

- Forged brass manifold with exclusive lifetime warranty
- Die cast, anodized aluminum, oil-bath crankcase
- Solid ceramic plungers with continuously lubricated packings
- The original Interpump unitized, stainless steel, K01 inlet and outlet valves
- Ideal for all general cleaning , RO, and misting applications
- Comes standard with NEMA 56C electric motor mounting flange
- Also available in “L” left-handed versions



SPECIFICATIONS

Pump Model	TT1505EBF	T9051EBF	TT9111EBF	TT9061EBF	TT9071EBF	TT2021EBF	TT2028EBF	TT2035EBF
Maximum Volume	0.5 GPM	2.11 GPM	3.0 GPM	2.11 GPM	2.8 GPM	2.1 GPM	2.8 GPM	3.5 GPM
Maximum Discharge Pressure	1500 PSI					2000 PSI		
Maximum Pump Speed	1750 RPM			3400 RPM				
Maximum Inlet Pressure	125 PSI							
Maximum Inlet Vacuum	3 ft. water (2.6 in. Hg)							
Bore (in./mm)	.709 / 18	.591 / 15	.709 / 18	.591 / 15				
Stroke (in./mm)	.079 / 2	.370 / 9.4	.370 / 9.4	1.97 / 5	.260 / 6.6	1.97 / 5	.260 / 6.6	.315 / 8
Crankcase Oil Capacity	11.2 oz.							
Maximum Fluid Temperature	165°F							
Inlet Port Thread	3/8-19 BSPP-F							
Discharge Port Thread	1/4-19 BSPP-F							
Shaft Diameter	5/8 in. / 16 mm							3/4 in./19 mm
Weight	11.5 lbs.							
Dimensions	7.0 x 7.2 x 5.5 in.							

TT Series 51 – EBF

GENERAL PUMP *A member of the Interpump Group*

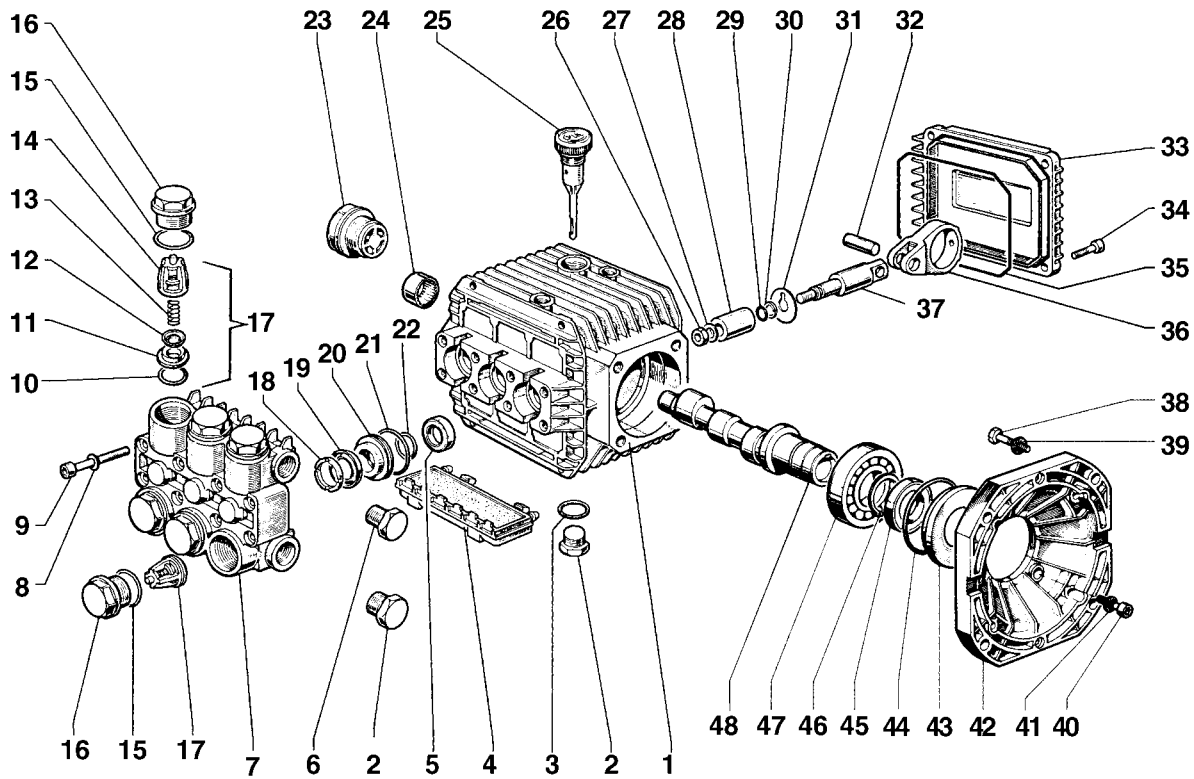

PARTS LIST

ITEM	PART NO.	DESCRIPTION	KIT	QTY.	ITEM	PART NO.	DESCRIPTION	KIT	QTY.	ITEM	PART NO.	DESCRIPTION	KIT	QTY.
1.	51.0106.22	Crankcase	1		19.	90.2620.00	Packing	96,97	3	34.	99.1867.00	Screw, M6 x 18	4	
2.	98.2100.00	Plug, 3/8-BSPP	2			90.2681.00	18mm (TT9111)	140,141		35.	90.3917.00	Gasket	1	
3.	90.3833.00	O-Ring, .549 x .103	1		20.	51.0800.70	Packing Retainer	86,96	3	36.	51.0300.22	Connecting Rod End	3	
4.	51.2091.02	Protector	1			51.0803.70	(TT9111)	139,140		37.	51.0500.56	Piston Guide	3	
5.	90.1565.00	Oil Seal	83	3	21.	90.3604.00	O-Ring, .989 x .070 (TT9111)	86,96,97	3	38.	99.3345.00	Screw, 3/8-BSPP	4	
6.	98.2041.00	Plug	1					139,140,141		39.	96.7104.00	Washer, M10, Schnorr	4	
7.	51.1200.23	Manifold, Aluminum	1		22.	90.3835.00	O-Ring, .594 x .103	86,96,97	3	40.	99.1867.00	Screw, M6 x 18	4	
	51.1200.41	Manifold, Brass				90.3843.00	(TT9111)	139,140,141		41.	96.6938.00	Washer, M6.4, Schnorr	4	
	51.1204.41	Manifold, Brass (TT9111)			23.	97.5968.00	Sight Gauge		1	42.	10.0344.22	Flange	1	
8.	96.6938.00	Washer, M6.4, Schnorr	12		24.	91.8015.00	Needle Bearing		1	43.	50.2115.51	Spacer	1	
9.	99.1943.00	Screw, M6 x 40	12		25.	98.2103.00	Oil Dip Stick		1	44.	90.4097.00	O-Ring, 2.187 x .139	1	
10.	90.3841.00	O-Ring, .674 x .103	1	6	26.	92.2216.00	Nut, M8		3	45.	90.1644.00	Oil Seal	1	
11.	36.2003.66	Valve Seat	1	6	27.	96.7008.00	Washer, M8		3	46.	90.0667.00	Snap Ring	1	
12.	36.2001.76	Valve Plate	1	6	28.	51.0400.09	Plunger (15 mm)		3	47.	20.2835.21	Bearing	1	
13.	94.7376.00	Spring	1	6		51.0401.09	18 mm, Solid Ceramic (T9111)		3	48.	51.0222.65	Crankshaft (TT1505)	1	
14.	36.2002.51	Valve Cage	1	6	29.	90.3572.00	O-Ring, .208 x .070		3		51.0208.35	Crankshaft (TT9061, TT2021)		
15.	90.3847.00	O-Ring, .797 x .103	84	6		90.5022.00	Back-up Ring		3		51.0215.35	Crankshaft (T9051, TT9111)		
16.	98.2218.00	Valve Cap	84	6	30.	96.7070.00	Washer, Flinger		3		51.0209.35	Crankshaft (TT9071, TT2028)		
17.	36.7032.01	Valve Assembly	1	6	31.	97.7310.00	Connecting Rod Pin		3		51.0218.35	Crankshaft (TT2035)		
18.	51.1000.51	Head Ring	96,97	3	33.	51.1600.22	Crankcase Cover		1					
	51.1001.51	Head Ring (TT9111)	140,141											

REPAIR KITS

KIT NO.	1	83	84	86 (15mm)	96 (15mm)	97 (15mm)	139 (18mm)	140 (18mm)	141 (18mm)
ITEM NO.s INCLUDED IN KIT	10, 11, 12, 6, 7, 8 (17)	5	15, 16	20, 21, 22	18, 19, 20, 21, 22	18, 19, 21, 22	20, 21, 22	18, 19, 20, 21,	18, 19, 21, 22
NUMBER OF ASSEMBLIES IN KIT	6	3	6	3	1	3	3	1	3
NUMBER OF CYLINDERS KIT WILL SERVICE	3	3	3	3	1	3	3	1	3

TORQUE SPECS*

Position	Ft.-lbs.
2	29.4
6	14.7
9	8.8
16	33.1
23	13.2
26	11.0
34	7.3
38	22.1
40	7.3
49	14.7
52	7.3