

FEATURES

- Forged brass manifold with exclusive lifetime warranty
- Die cast, anodized aluminum, oil-bath crankcase
- Solid ceramic plungers with continuously lubricated packings
- The original Interpump unitized, stainless steel, K01 inlet and outlet valves
- Ideal for all general cleaning applications
- Comes standard with SAE J609 gasoline engine mounting flange
- Also available in "L" left-handed versions

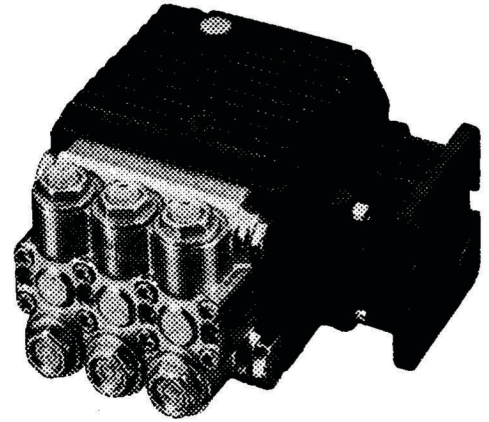

SPECIFICATIONS

Pump Model	TT9061GBF	TT9071GBF	TT1540GBF	TT2028GBF	TT2035GBF
Maximum Volume	2.11 GPM	2.8 GPM	4.0 GPM	2.8 GPM	3.5 GPM
Maximum Discharge Pressure	1500 PSI			2000 PSI	
Maximum Pump Speed	3400 RPM				
Maximum Inlet Pressure	125 PSI				
Maximum Inlet Vacuum	3 ft. water (2.6 in. Hg)				
Bore	.591 in. / 15 mm				
Stroke (in./mm)	.197 / 5	.260 / 6.6	.370 / 9.4	.260 / 6.6	.315 / 8
Crankcase Oil Capacity	11.2 oz.				
Maximum Fluid Temperature	165°F				
Inlet Port Thread	3/8-19 BSPP-F				
Discharge Port Thread	1/4-19 BSPP-F				
Shaft Diameter	3/4 in. / 19 mm				
Weight	11.4 lbs.				
Dimensions	7.2 x 7.2 x 5.5 in.				

DIMENSIONAL DRAWING

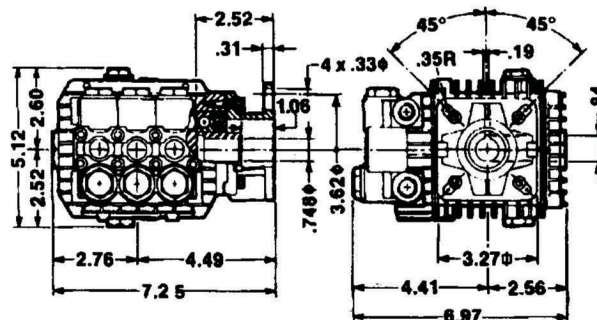

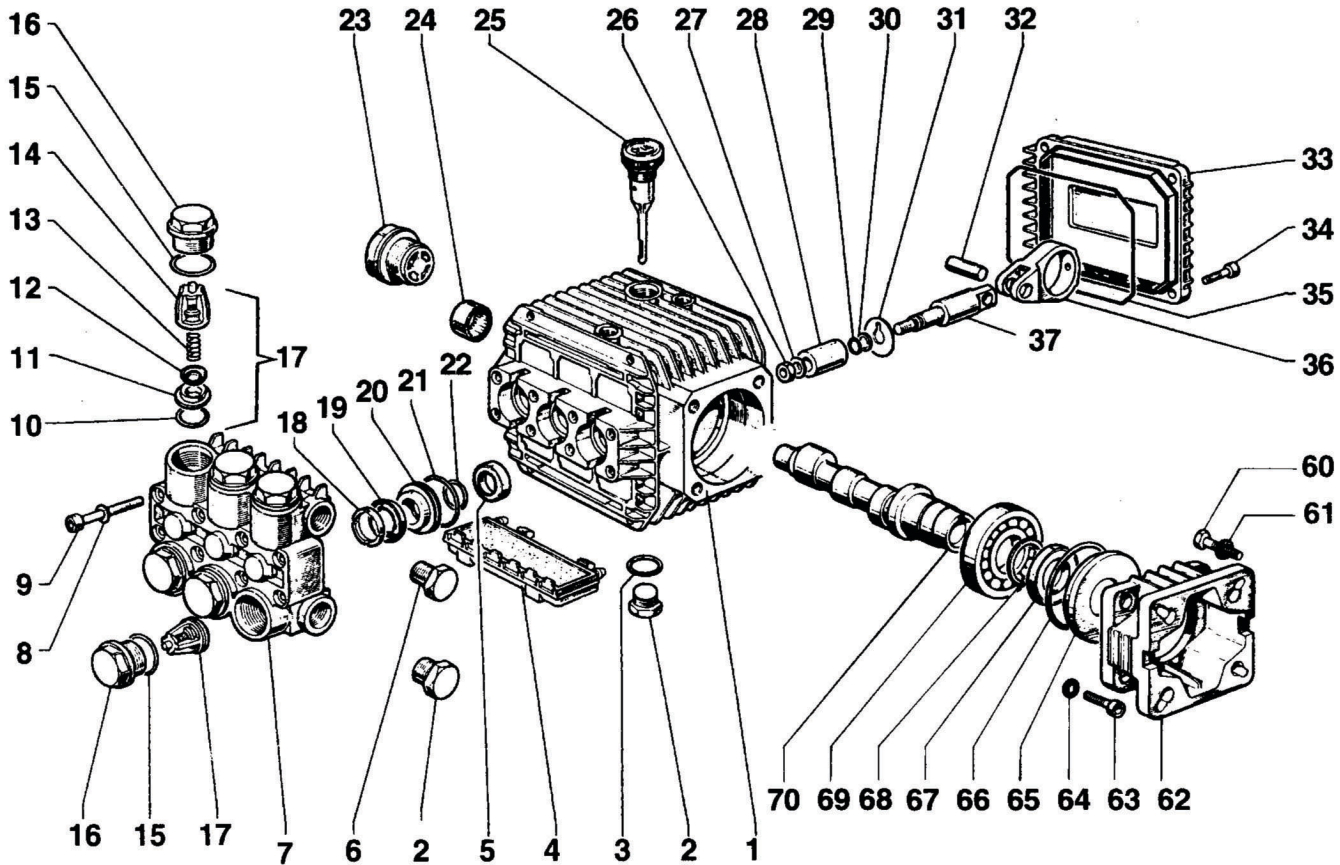

PARTS LIST

ITEM	PART NO.	DESCRIPTION	KIT	QTY.	ITEM	PART NO.	DESCRIPTION	KIT	QTY.	ITEM	PART NO.	DESCRIPTION	KIT	QTY.
1.	51.0106.22	Crankcase	1	1	17.	36.7032.01	Valve Assembly	1	6	35.	90.3917.00	O-Ring	1	1
2.	98.2100.00	Plug, 3/8-BSPP	2	1	18.	51.1000.51	Head Ring	96,97	3	36.	51.0300.22	Connecting Rod	3	3
3.	90.3833.00	O-Ring, .549 x .103	1	2	19.	90.2620.00	Packing	96,97	3	37.	51.0500.56	Piston Guide	3	3
4.	51.2091.02	Protector	1	1	20.	51.0800.70	Packing Retainer	86,96	3	60.	99.2730.00	Screw, 5/16"	4	4
5.	90.1565.00	Oil Seal	83	3	21.	90.3604.00	O-Ring, .989 x .070	86,96,97	3	61.	96.7014.00	Washer, M8.4, Schnorr	4	4
6.	98.2041.00	Plug	1	1	22.	90.3835.00	O-Ring, .594 x .103	86,96,97	3	62.	10.0346.22	Flange	1	1
7.	51.1200.41	Manifold, Brass	1	1	23.	97.5968.00	Sight Gauge		1	63.	99.1867.00	Screw, M6 x 18	4	4
	51.1200.22	Manifold, Aluminum			24.	91.8015.00	Needle Bearing		1	64.	96.6938.00	Washer, M6.4, Schnorr	4	4
8.	96.6938.00	Washer, M6.4, Schnorr	12	12	25.	98.2103.00	Oil Dip Stick		1	65.	50.2115.51	Spacer	1	1
9.	99.1943.00	Screw, M6 x 40	12	12	26.	92.2216.00	Nut, M8		3	66.	90.4097.00	O-Ring, 2.187 x .139	1	1
10.	90.3841.00	O-Ring, .674 x .103	1	6	27.	96.7008.00	Washer, M8		3	67.	90.1644.00	Oil Seal	1	1
11.	36.2003.66	Valve Seat	1	6	28.	51.0400.09	Plunger (15 mm)		3	68.	90.0667.00	Snap Ring	1	1
12.	36.2001.76	Valve Plate	1	6	29.	90.3572.00	O-Ring, .208 x .070		3	69.	20.2835.21	Bearing	1	1
13.	94.7376.00	Spring	1	6	30.	90.5022.00	Back-up Ring		3	70.	51.0210.35	Crankshaft (TT9061)	1	1
14.	36.2002.51	Valve Cage	1	6	31.	96.7070.00	Washer, Flinger		3		51.0211.35	Crankshaft (TT9071, TT2028)		
15.	90.3847.00	O-Ring, .797 x .103	84	6	32.	97.7310.00	Connecting Rod Pin		3		51.0219.65	Crankshaft (TT1540)		
16.	98.2218.00	Valve Cap	84	6	33.	51.1600.22	Crankcase Cover		1		51.0218.35	Crankshaft (TT2035)		
					34.	99.1867.00	Screw		4					

REPAIR KITS

KIT NO.	1	83	84	86	96	97
ITEM NO.s INCLUDED IN KIT	10, 11, 12, 6, 7, 8 (17)	5	15, 16	20, 21, 22	18, 19, 20, 21, 22	18, 19, 21, 22
NUMBER OF ASSEMBLIES IN KIT	6	3	6	3	1	3
NUMBER OF CYLINDERS KIT WILL SERVICE	3	3	3	3	1	3

TORQUE SPECS*

Position	Ft.-lbs.
2	29.4
6	14.7
9	8.8
16	33.1
23	13.2
26	11.0
34	7.3
38	22.1
40	7.3
49	14.7
52	7.3

*Decrease torque by 20% if threads are lubricated.



- Features a Built-In Unloader, with optional Chemical Injector and optional Inlet Fitting
- Available in Aluminum (1300 PSI Maximum) or Brass (1500 PSI Maximum)

General Pump recommends using a GRV safety relief device in conjunction with this unloader valve when installed on a positive displacement pump. General Pump is not liable and assumes no responsibility for this valve when used in a customer's high pressure system.

PARTS LIST

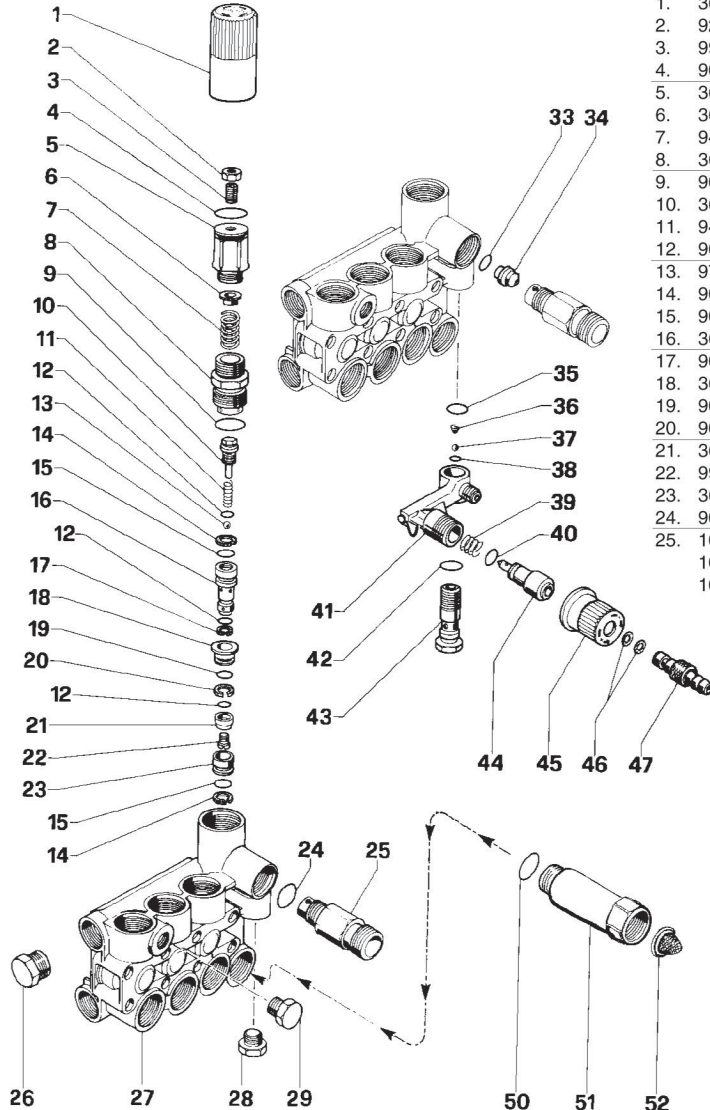

NO.	PART NO.	DESC.	KIT NO.	QTY.	NO.	PART NO.	DESC.	KIT NO.	QTY.
1.	36.3187.51	Knob		1	26.	98.2041.00	Cap, 1/4 BSPP		1
2.	92.2218.00	Nut		1		90.2100.00	Cap, 3/8 BSPP		
3.	99.3054.00	Screw		1	27.	55.1200.22	Manifold Alum.		1
4.	90.3598.00	O-Ring		1		51.1201.41	Manifold Brass		
5.	36.3185.70	Press Regulator		1	28.	98.2057.00	Cap		1
6.	36.3169.70	Seat		1	29.	98.2041.00	Cap		1
7.	94.7436.00	Spring		1	OPTIONAL				
8.	36.3184.70	Bushing	102	1	33.	90.3822.00	O-Ring	94,102	1
9.	90.3847.00	O-Ring	102	1	34.	10.0151.66	Nozzle, 2.0mm		1
10.	36.3188.70	Stopper	102	1		10.0076.66	Nozzle, 2.2mm		
11.	94.7332.00	Spring	102	1	35.	90.3582.00	O-Ring	94	1
12.	90.3575.00	O-Ring	102	3	36.	94.8217.00	Spring	94	1
13.	97.4800.00	Ball	102	1	37.	97.4782.00	Ball	94	1
14.	90.5065.00	Anti-Ext. Ring	102	3	38.	90.3572.00	O-Ring	94	1
15.	90.3822.00	O-Ring	102	2	39.	94.7383.00	Spring	94	1
16.	36.3189.70	Control Piston	102	1	40.	90.3580.00	O-Ring	94	1
17.	90.5025.00	Anti-Ext. Ring	102	1	41.	36.3181.51	Body		1
18.	36.3165.70	Valve Guide	102	1	42.	90.3585.00	O-Ring	94	1
19.	90.3589.00	O-Ring	102	1	43.	36.2563.70	Valve Seat		1
20.	90.5075.00	Anti-Ext. Ring	102	1	44.	36.2564.70	Shutter		1
21.	36.3190.66	Valve	102	1	45.	36.2565.51	Knob		1
22.	99.1509.00	Screw	102	1	46.	90.3570.00	O-Ring	94	2
23.	36.3164.66	Valve Seat	102	1	47.	36.2566.70	Coupling		1
24.	90.3832.00	O-Ring	94	1	OPTIONAL				
25.	10.0078.70	Fitting, 3/8 BSPP		1	50.	701115	O-Ring		1
	10.0147.70	Fitting, M22			51.	680006	Inlet Fitting		1
	10.0318.70	Fitting, 3/8 NPT			52.	700004	Filter Washer		1

Kit No.	94	102
Item No's. in Kit	24-33-35 36-37-38-39 40-42-46	8-9-10-11-12 13-14-15-16 17-18-19-20 21-22-23-33
Qty.	1	1

