

T Series 69

36 mm bore – Triplex Plunger Pump

FEATURES

- The industry's choice for high-flow applications
- Large-capacity, die-cast, anodized aluminum oil-bath crankcase
- Over-sized connecting rods for maximum life
- Heavy-duty tapered roller bearing.
- Solid ceramic plungers with continuously lubricated packings
- Unitized stainless steel inlet and discharge valves

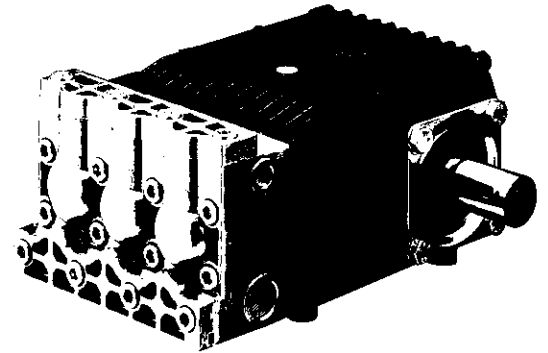

SPECIFICATIONS

Pump Model	T41
Maximum Volume	12.0 GPM
Maximum Discharge Pressure	900 PSI
Maximum Pump Speed	650 RPM
Maximum Inlet Pressure	125 PSI
Maximum Inlet Vacuum	9 ft. water (7.9 in. Hg)
Bore	1.417 in. / 36 mm
Stroke	.945 in. / 24 mm
Crankcase Oil Capacity	50.7 oz.
Maximum Fluid Temperature	165°F
Inlet Port Thread	3/4-14 BSPP-F
Discharge Port Thread	3/8-19 BSPP-F
Shaft Diameter.	1.378 in. / 35 mm
Weight	37 lbs.
Dimensions	12.9 x 11.9 x 7.3 in.

T Series 69 – 36 mm bore

GENERAL PUMP

A member of the Interpump Group

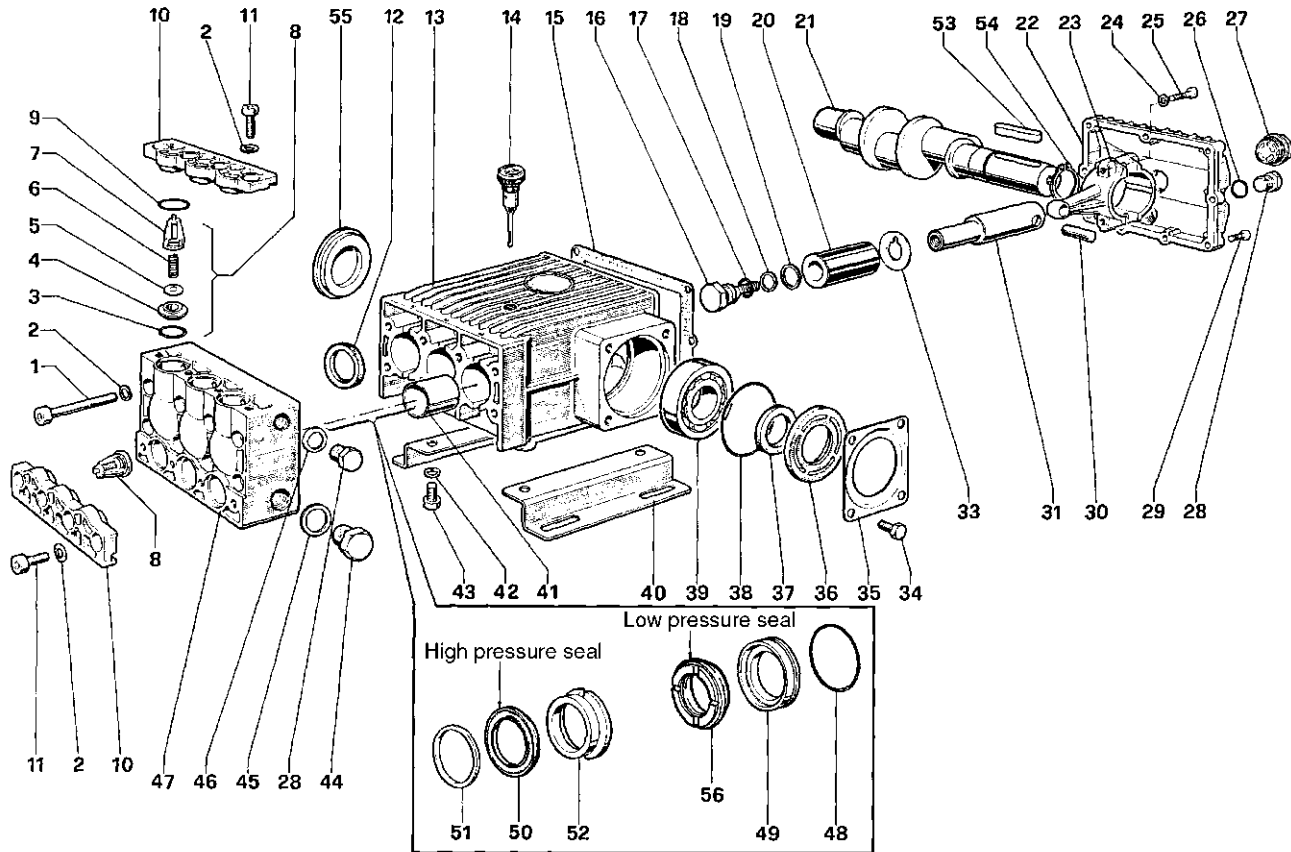

PARTS LIST

ITEM PART NO.	DESCRIPTION	KIT NO.	QTY.	ITEM PART NO.	DESCRIPTION	KIT NO.	QTY.	ITEM PART NO.	DESCRIPTION	KIT NO.	QTY.
1.	99.3787.00 Screw		8	19.	96.7555.00 Washer	74	3	38.	90.4131.00 O-Ring		2
2.	96.7104.00 Washer		16	20.	69.0400.09 Plunger (36 mm)		3	39.	91.8480.00 Bearing		2
3.	90.3859.00 O-Ring	62	6	21.	69.0205.35 Crankshaft		1	40.	47.2000.74 Feet		2
4.	36.2017.66 Valve Seat	62	6	22.	69.1600.22 Cover		1	41.	90.9162.00 Bushing		3
5.	36.2018.76 Valve Plate	62	6	23.	69.0300.01 Connecting Rod		3	42.	96.7106.00 Washer		4
6.	94.7394.00 Spring	62	6	24.	96.7014.00 Washer		6	43.	99.3644.00 Screw		4
7.	36.2008.51 Valve Guide	62	6	25.	99.3099.00 Screw		6	44.	98.2265.00 Cap		1
8.	36.7060.01 Valve Assy.	62	6	26.	90.3833.00 O-Ring		1	45.	96.7700.00 Washer		1
9.	90.4055.00 O-Ring		6	27.	97.5968.00 Oil Level Indicator		1	46.	96.7380.00 Washer		1
10.	69.2180.22 Valve Cover		2	28.	98.2100.00 Cap		2	47.	69.1200.22 Pump Head		1
11.	99.3669.00 Screw		8	29.	99.1867.00 Screw		9	48.	90.3855.00 O-Ring	39, 40	3
12.	90.1656.00 Oil Seal	37	3	30.	97.7398.00 Pin		3	49.	69.0802.70 Packing Retainer	39, 40	3
13.	69.0100.22 Crankcase		1	31.	69.0500.22 Plunger Guide		3	50.	90.2820.00 Packing	38, 39	3
14.	98.2106.00 Oil Dip Stick		1	33.	96.7565.00 Washer		3	51.	69.1002.93 Head Ring	39, 41	3
15.	69.2119.84 Cover Gasket		1	34.	99.3636.00 Screw		8	52.	69.2168.70 Intermediate Ring	39, 42	3
16.	69.2195.66 Plunger Screw	74	3	35.	68.1500.74 Cover		2	53.	91.4969.00 Key		1
17.	90.3841.00 O-Ring	74	3	36.	69.2115.51 Spacer		1	54.	90.0695.00 Retaining Ring		1
18.	90.5107.00 Anti-Ext. Ring	74	3	37.	90.1672.00 Oil Seal	32	1	55.	69.2116.51 Spacer		1
								56.	90.2823.00 Seal, Low Press., 36mm	38, 39	3

REPAIR KITS

	32	37	38	39	40	41	42	62	74
KIT NO.									
ITEM NO.s INCLUDED IN KIT	37	12	50, 56	48, 49, 50, 51, 52, 56	48, 49	51	52	3, 4, 5, 6, 7 (8)	16, 17, 18, 19
NUMBER OF ASSEMBLIES IN KIT	2	3	3	1	3	6	3	6	3
NUMBER OF CYLINDERS KIT WILL SERVICE	-	3	3	1	3	3	3	3	3

TORQUE SPECS*

Position	Ft.-lbs.
1	29.4
11	44.2
16	29.4
25	14.7
27	13.2
28	29.4
29	7.3
34	29.4
43	29.4
44	51.5