

T Series 77

20 mm bore – Sixplex Plunger Pump

FEATURES

- Nickel-plated forged brass manifold with exclusive lifetime warranty
- Unique “in-line” valve system for easy access and durability
- High pressure and high flow option
- Dual manifolds utilizing a common crankcase for efficient performance
- Proven crankcase and bearing design
- Bronze connecting rods for maximum life

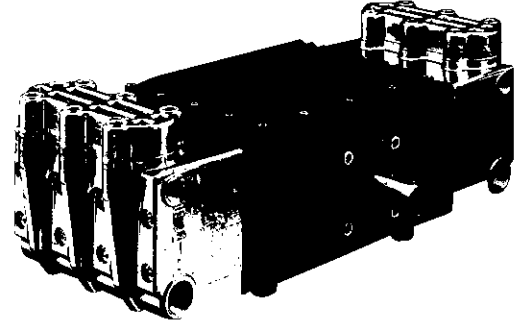

SPECIFICATIONS

Pump Model	T3551-N
Maximum Volume	13.0 GPM
Maximum Discharge Pressure	4350 PSI
Maximum Pump Speed	1000 RPM
Maximum Inlet Pressure	125 PSI
Maximum Inlet Vacuum	7 ft. water (6.2 in. Hg)
Bore	.787 in. / 20 mm
Stroke	1.102 / 28
Crankcase Oil Capacity	71 oz.
Maximum Fluid Temperature	165°F
Inlet Port Thread	1-11 BSPP-F
Discharge Port Thread	1/2-14 BSPP-F
Shaft Diameter.	1.378 in. / 35 mm
Weight	174 lbs.
Dimensions	25.2 x 14.0 x 10.0 in.

T Series 77 – 20 mm bore

GENERAL PUMP *A member of the Interpump Group*

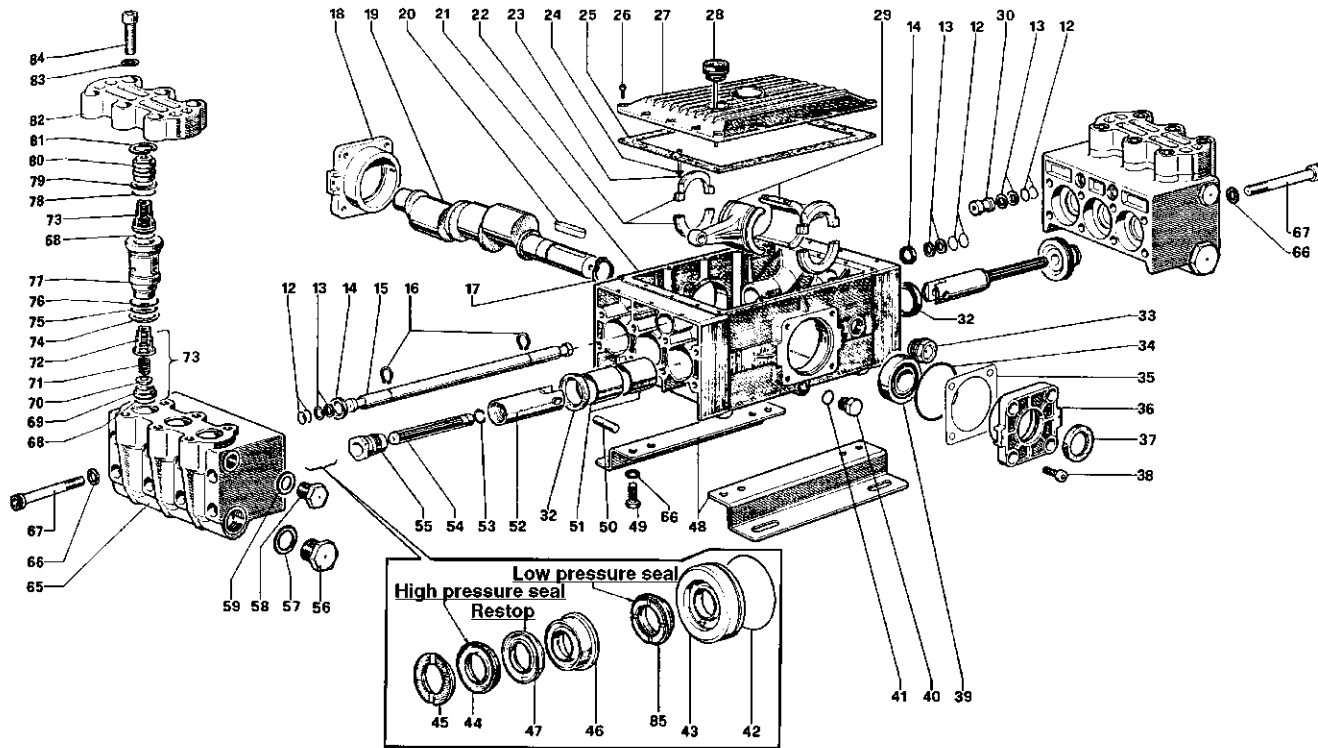

PARTS LIST

ITEM PART NO.	DESCRIPTION	KIT NO.	QTY.	ITEM PART NO.	DESCRIPTION	KIT NO.	QTY.	ITEM PART NO.	DESCRIPTION	KIT NO.	QTY.
12.	90.3835.00	O-Ring	8	35.	76.2200.78	Shim	2	58.	98.2178.00	Cap	3
13.	90.5090.00	Anti-Ext. Ring	8	36.	76.1500.22	Cover	1	59.	96.7514.00	Washer	3
14.	90.1614.00	Ring	4	37.	90.1672.00	Ring	32	65.	62.1202.41	Manifold	2
15.	62.2123.92	Connect. Tube	1	38.	99.3652.00	Screw	8	66.	96.7195.00	Washer	20
16.	90.0605.00	Cir-Clip	2	39.	91.8474.00	Bearing	2	67.	99.4465.00	Screw	16
17.	90.0695.00	Cir-Clip	1	40.	98.2100.00	Cap	1	68.	90.3850.00	O-Ring	122
18.	76.1501.22	Cover	1	41.	90.3833.00	O-Ring	1	69.	36.2024.66	Valve Seat	122
19.	76.0210.35	Crankshaft	1	42.	90.3903.00	O-Ring	76, 78	70.	36.2013.66	Valve	122
20.	91.4978.00	Key	1	43.	61.0800.70	Packing Retainer	76, 78	71.	94.7394.00	Spring	122
21.	77.0100.22	Crankcase	1	44.	90.2705.00	Packing	77, 78	72.	36.2023.51	Valve Guide	122
22.	77.2120.01	Holding Ring	6	45.	47.1000.51	Head Ring	7, 78	73.	36.7114.01	Valve Assy.	122
23.	99.1927.00	Screw	12	46.	61.2160.70	Intermed. Ring	75, 78	74.	90.5181.00	Anti-Ext. Ring	6
24.	96.6938.00	Washer	12	47.	90.2709.00	Ring	77, 78	75.	90.4057.00	O-Ring	6
25.	77.2118.84	Gasket	1	48.	76.2000.74	Foot	2	76.	90.3871.00	O-Ring	6
26.	99.1867.00	Screw	16	49.	99.4266.00	Screw	4	77.	61.2177.66	Bushing	6
27.	77.2114.22	Cover	1	50.	97.7400.00	Plunger Pin	6	78.	90.3855.00	O-Ring	6
28.	98.2272.00	Oil Dip Stick	1	51.	90.9172.00	Bushing	12	79.	90.5154.00	Anti-Ext. Ring	3
29.	77.0302.41	Connect. Rod	3	52.	61.0500.66	Plunger Guide	6	80.	61.2176.70	Cap	6
30.	62.2130.70	Cap	2	53.	90.0115.00	Cir-Clip	6	81.	90.0670.00	Cir Clip	6
32.	90.1670.00	O-Ring	44	54.	61.0400.56	Plunger (20 mm)	6	82.	61.2182.41	Valve Cover	2
33.	97.5968.00	Oil Indicator	1	55.	61.2195.66	Plunger Screw	6	83.	96.7300.00	Washer	12
34.	90.4141.00	O-Ring	2	56.	98.2325.00	Cap	2	84.	99.4860.00	Screw	12
				57.	96.7870.00	Washer	2	85.	90.2710.00	Seal, Low Press., 20mm	77, 78
											6

REPAIR KITS

KIT NO.	7	32	44	75	76	77	78	122
ITEM NO.s INCLUDED IN KIT	45	37	32	46	42, 43	44, 47, 85	42, 43, 44, 45, 46, 47, 85	68, 69, 70, 71, 72 (73)
NUMBER OF ASSEMBLIES IN KIT	6	2	3	3	3	3	1	6
NUMBER OF CYLINDERS KIT WILL SERVICE	3	-	3	3	3	3	1	3

TORQUE SPECS*

Position	Ft.-lbs.
23	8.8
26	7.3
33	13.2
38	13.2
40	29.4
49	29.4
55	81.0
58	36.8
67	51.5
84	95.8