



GENERAL PUMP

A member of the Interpump Group

Industrial

MSS

Jetter Series Triplex-Plunger Pump

Owner's Manual

- *Installation*
- *Use*
- *Maintenance*



INDUSTRIAL

INDUSTRIAL

GENERAL PUMP 1174 Northland Drive • Mendota Heights, MN 55120

Phone: (651)686-2199 • Fax: (800)535-1745 • e-mail: sales@gpcompanies.com • www.generalpump.com



INDEX

page

1. INTRODUCTION	1
2. GENERAL WARNINGS FOR SAFE OPERATION	1
a. Fluid injection hazard	1
b. Fuel and emission hazards: engine driven products	2
c. Grounding instructions: motor driven products	2
d. Extension cords: motor driven products	3
e. Equipment misuse hazard	3
f. Hose safety	3
g. Moving parts hazard	4
h. Terms	4
3. PUMP IDENTIFICATION	5
4. TECHNICAL FEATURES	5
5. CONSTRUCTION FEATURES	6
6. GENERAL INFORMATION ON PUMP USE	7
a. Water temperature	7
b. Pump performance	7
7. CONNECTIONS AND PLUGS	7
8. PUMP INSTALLATION	8–9
a. Positioning	8
b. Direction of rotation	8
c. Hydraulic connections	8
d. Pump feeding	8
e. Suction line	8
f. Filtration	9
g. Delivery line	9
9. START-UP AND RUNNING PROCEDURES	10
a. Start-up checks	10
b. Start-up and operation	10
c. Cooling system	10
10. MAINTENANCE INSTRUCTIONS	10–17
a. Crank mechanism maintenance	10
b. Fluid end maintenance	11
c. Pressure packings and plunger maintenance	11–12
d. Fastener torque values	12
e. Parts breakdown	14–17
11. PUMP STOPPED FOR LONG PERIOD	13
12. FROST PRECAUTIONS	13
13. MSS MODELS	13

1. INTRODUCTION

The General Pump MSS series of high pressure plunger pumps have been designed for long life. They will provide a long period of trouble free operation, if they are correctly installed and maintained.

Read this manual carefully before using your pump. It contains necessary information for correct installation, use and maintenance, and practical trouble shooting suggestions.

2. GENERAL WARNINGS FOR SAFE OPERATION



WARNING: The misuse of a high pressure water unit and improper pump installation and maintenance increases the risk of personal injury and serious damage to the equipment.



WARNING: High pressure spray can cause serious injury. For professional use only. Observe all warnings.



WARNING: Read and understand all instruction manuals before operating equipment.

2a. Fluid injection hazard

General safety

This pump generates very high fluid pressure. Spray from a gun, leaks or ruptured components can inject fluid through your skin and into your body and cause extremely serious bodily injury including the need for amputation. Also, fluid injected or splashed into the eyes or on the skin can cause serious damage.

- **Never** point the spray gun or wand at anyone or at any part of the body. **Never** put hand or fingers over the spray tip.
- **Always** follow the **PRESSURE RELIEF PROCEDURE**, **before** cleaning or servicing any part of the system.
- **Never** try to stop or deflect leaks with your hand or body.
- Be sure all equipment safety devices are operating properly before each use.
- **Always** install a pressure relief valve sized to discharge (bypass) 110% of the maximum pump flow rate.
- Protect all components from environmental damage and high pressure water spray.
- **Always** restrict access to the area to properly trained and required personnel.
- Keep the area clear of debris and loose items.
- **Always** use only genuine General Pump replacement parts when servicing the pump.

Medical treatment

If any fluid appears to penetrate your skin, get **EMERGENCY MEDICAL TREATMENT AT ONCE. DO NOT TREAT AS A SIMPLE CUT.** Tell the doctor exactly what fluid was injected.

NOTE TO PHYSICIAN: *Injection in the skin is a traumatic injury. It is important to treat the injury surgically as soon as possible. Do not delay treatment to research toxicity. Toxicity is a concern with some exotic coatings injected directly into the bloodstream. Consultation with a plastic surgeon or reconstructive hand surgeon may be advisable.*

Pressure relief procedure

To reduce the risk of serious bodily injury, including fluid injection and splashing in the eyes or on the skin, always follow this procedure whenever you stop spraying for more than 10 minutes, when shutting down, and before checking or repairing any part of the system.

1. Engage the trigger safety latch.
2. Turn the system off.
3. Disconnect the power supply.
4. Shut off the water supply.
5. Disengage the trigger safety latch and trigger the gun to relieve pressure, and then engage the trigger safety latch again.
6. Before long-term (overnight) storage, disconnect the water supply and disconnect the power supply.

Spray gun safety devices

Be sure all gun safety devices are operating properly before each use. Do not remove or modify any part of the gun; this can cause a malfunction and result in serious bodily injury.

Safety latch: Whenever you stop spraying for a moment, always set the gun safety latch in the engaged or “safe” position, making the gun inoperative. Failure to properly set the safety latch can result in accidental triggering of the gun.

Spray tip safety: Use extreme caution when cleaning or changing spray tips. If a spray tip clogs while spraying, engage the gun safety latch immediately. **Always** follow the **PRESSURE RELIEF PROCEDURE** and then remove the spray tip to clean it.

2b. Fuel and emission hazards: engine driven products

Never fill the fuel tank while the unit is running or hot. The fuel used in this unit is combustible and when spill on a hot surface can ignite and cause a fire. **Always** fill tank slowly to avoid spilling.

Never operate the unit in a closed building. The exhaust contains carbon monoxide, a poisonous, odorless, invisible gas which can cause serious injury or death if inhaled.

Never alter the maximum throttle setting, which is factory set. Tampering with this adjustment can damage the pressure washer and will void the warranty.

2c. Grounding instructions: motor driven products

This product must be grounded. If it should malfunction or break down, grounding provides a path of least resistance for electric current to reduce the risk of electric shock. If the equipment is equipped with a cord having an equipment-grounding conductor and a grounding plug, the plug must be plugged into an appropriate outlet that is properly installed and grounded in accordance with all local codes and ordinances.



DANGER: Improper connection of the equipment-grounding conductor can result in the risk of electrocution. Check with a qualified electrician or service person if you are in doubt as to whether an outlet is properly grounded. Do not modify any plug provided with the product – if it will not fit the outlet, have a proper outlet installed by a qualified electrician.

2d. Extension cords: motor driven products

Use only 4-wire extension cords that have 4-prong grounding-type plugs and 4-pole cord connectors that accept the plug from the product. Use only extension cords that are intended for outdoor use. These extension cords are identified by a marking, "Acceptable for use with outdoor appliances; store indoors while not in use." Use only extension cords having an electrical rating not less than the rating of the product. Do not use damaged extension cords. Examine extension cord before using and replace if damaged. Do not abuse extension cord and do not yank or pull on any cord to disconnect. Keep cord away from heat and sharp edges. Always disconnect the extension cord from the receptacle before disconnecting the product from the extension cord.



WARNING: To reduce the risk of electrocution, keep all connections dry and off the ground. Do not touch plug with wet hands.

2e. Equipment misuse hazard

General safety

Any misuse of the pump or accessories, such as overpressurizing, modifying parts, using incompatible chemicals and fluids, or using worn or damaged parts, can cause them to rupture and result in fluid injection, splashing in the eyes or on the skin, or other serious bodily injury, fire, explosion or property damage.

Never alter or modify any part of this equipment; doing so could cause it to malfunction.

Check all equipment regularly and repair or replace worn or damaged parts immediately.

Always wear protective eyewear, hearing protection and appropriate clothing. If using a chemical, read and follow the chemical manufacturer's literature for recommendations on additional protective equipment, such as a respirator.

System pressure

This pump can develop high operating pressure. Be sure that all equipment and accessories are rated to withstand the maximum working pressure of this system. **Do not** exceed the maximum working pressure of any component or accessory used in the system.

Chemical compatibility

Be sure that all chemicals used are compatible with the wetted parts as given in the Technical Data. Always read the chemical manufacturer's literature before using any chemical.

2f. Hose safety

High pressure fluid in the hoses can be very dangerous. If the hose develops a leak, split or rupture due to any kind of wear, damage or misuse, the high pressure spray emitted from it can cause a fluid injection injury or other serious bodily injury or property damage.

ALL FLUID HOSES MUST HAVE STRAIN RELIEFS ON BOTH ENDS. The strain reliefs help protect the hose from kinks or bends at or close to the coupling, which can result in hose rupture.

Tighten all fluid connections securely before each use. High pressure fluid can dislodge a loose coupling or allow high pressure spray to be emitted from the coupling.

Never use a damaged hose. Before each use, check entire hose for cuts, leaks, abrasion, bulging cover, or damage or movement of the hose couplings. If any of these conditions exist, replace the hose immediately.

Do not try to recouple high pressure hose or mend it with tape or any other device. A repaired hose cannot contain the high pressure fluid.

HANDLE AND ROUTE HOSES CAREFULLY. Do not pull on hoses. Do not use chemicals which are not compatible with the inner tube and cover of the hose. **Do not** expose hose to temperatures above 200° F (93° C) or below -40° F (-40° C).

2g. Moving parts hazard

Moving parts can pinch or amputate fingers or other body parts. **Keep clear** of moving parts when starting or operating the system.

Never operate the system without all guards and interlocks installed and functioning. Follow the **PRESSURE RELIEF PROCEDURE** before checking or servicing the pressure washer to prevent discharging high pressure fluid from the gun.

2h. Terms

WARNING or **DANGER:** Alerts user to avoid or correct conditions that could cause bodily injury.

CAUTION: Alerts user to avoid or correct conditions that could cause damage to the equipment.

NOTE: Identifies helpful procedures and information.

IMPORTANT: United States Government safety standards have been adopted under the Occupational Safety and Health Act. These standards – particularly the General Standards, Part 1910, and the Construction Standards, Part 1926 – should be consulted.

3. PUMP IDENTIFICATION

Each pump is fitted with a rating plate. The specifications stamped on it are as follows:

- pump model and version
- maximum rpm
- maximum pressure and volume
- crankcase oil capacity and specification
- serial number

The pump model, pump version and serial number data must be specified when ordering spare parts. If the pump is modified, any change should be mentioned on the rating plate for future reference.

4. TECHNICAL FEATURES

The pump features:

- three horizontal plungers and five different bore sizes
- vertically-arranged valves
- double V-shaped pressure packings lubricated by a water drip feed system and routine greasing
- splash lubricated crank mechanism
- pulley, flexible joint or PTO shaft drive capabilities
- available without gear reduction or with 2:1 or 2.4:1 gear reduction. Gear boxes can be fitted on the left or right side of the pump in different positions according to customer requirements

PUMP MODELS

MODEL	RPM*	Volume	Pressure**	Power	
		GPM	PSI	KW	HP
MSS 36	750	35.6	5000	91.0	122
	1500	35.4	5000	90.5	121.2
	1800	35.9	5000	91.7	123
MSS 40	750	44.1	3900	87.8	118
	1500	43.9	3900	87.5	117.2
	1800	44.4	3900	88.5	118.6
MSS 45	750	56.0	3050	87.2	117
	1500	55.5	3050	86.5	116
	1800	56.3	3050	87.7	117.6
MSS 50	750	69.2	2470	87.3	117
	1500	68.7	2470	86.7	116.2
	1800	69.5	2470	87.7	117.6
MSS 55	750	83.4	2000	85.2	114.2
	1500	83.0	2000	84.8	113.7
	1800	84.0	2000	85.8	115

Performances refer to theoretical delivery with 100% volumetric efficiency.
 **Ratings are for intermittent duty only. Please contact our technical staff in case of, heavy-duty or special applications.

FEATURES	
• Stroke	2.36 in (60 mm)
• Minimum Inlet Pressure	15 psi
• Maximum Inlet Pressure	45 psi
• Maximum Inlet Water Temperature	150° F
• Oil Capacity with gearbox	10.5 qts.
w/o gearbox	8.5 qts.
• Weight with gearbox	616 lbs.
w/o gearbox	520 lbs.

- ★ **750 RPM Crankshaft Speed**
No gear reduction
- 1500 RPM Crankshaft Speed**
2.037 gear reduction
Rated crankshaft speed 745 RPM
- 1800 RPM Crankshaft Speed**
2.417 gear reduction
Rated Crankshaft speed 736 RPM

with Gearbox

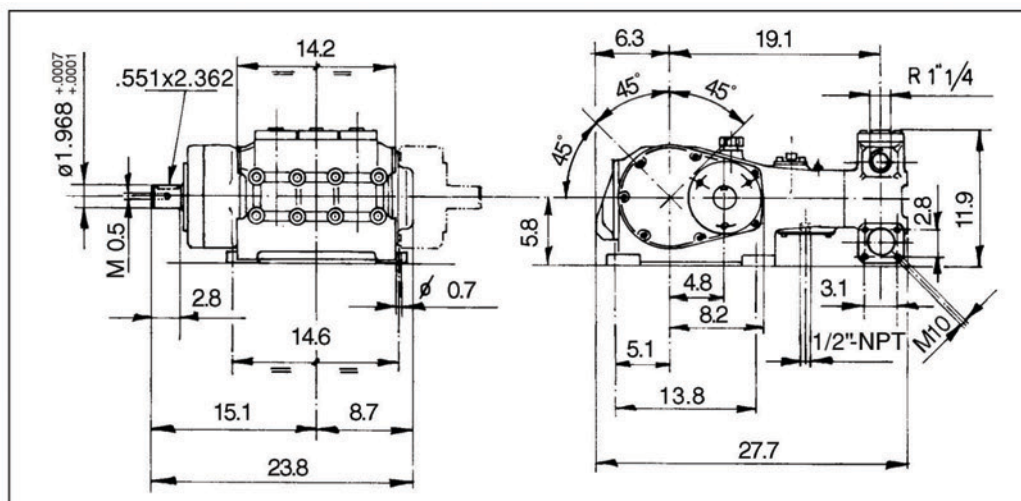

w/o Gearbox

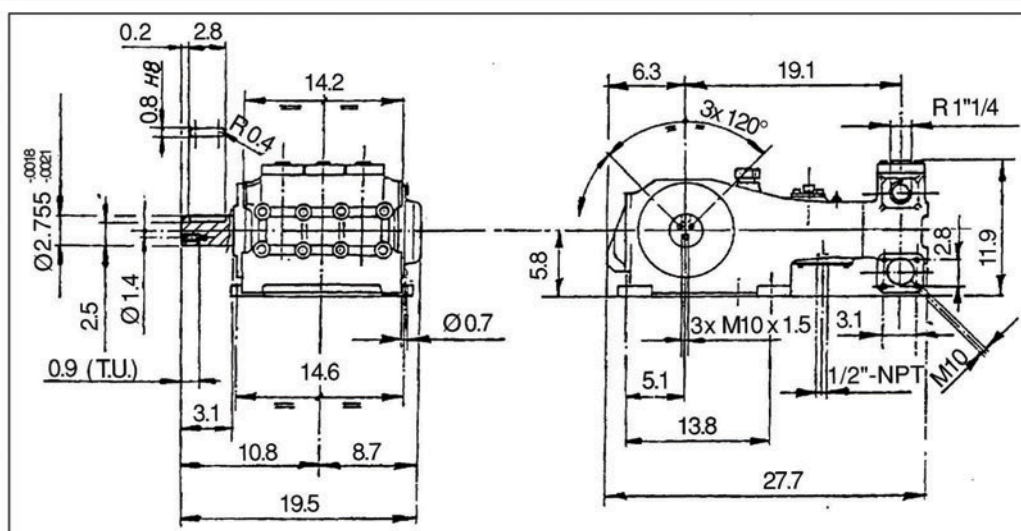

5. CONSTRUCTION FEATURES

The main components of the pump consist of:

- A. crank mechanism
- B. plunger and packing system
- C. manifold

A. CRANK MECHANISM Includes the cast iron crankcase containing the drive system components:

- gas-nitrided, hardened and tempered alloy steel crankshaft mounted on self-adjusting double roller shaft bearings.
- forged split connecting rods with special anti-friction bearings.
- surface-treated steel piston guides.
- splash lubricated by the pump crankcase oil.

B. PLUNGER AND PACKING SYSTEM Primarily composed of ceramic-coated stainless steel plungers and pressure packings with packing supports and cylinders. The pumping system is also greased to further improve the life of pressure packings and plungers.

C. MANIFOLD Contains the suction and high pressure valves, made of stainless steel and bronze (MSZ and MSN versions are stainless steel). Valve components come out as a single unit.

6. GENERAL INFORMATION ON PUMP USE

The MSS pump has been designed to pump, at room temperature, fresh, filtered water or other liquids of similar viscosity that are compatible with the wetted materials (for questionable liquids contact our Technical Department).

6a. Water temperature.

The maximum inlet water temperature is 150° F.

6b. Pump performance

Never exceed the maximum pump flow rate or pressure.

7. CONNECTIONS AND PLUGS

The MSS series pumps have:

- A. **66 MM Dia Inlet Ports (2)** Water supply connection to either or both ports is acceptable. (Use P/N F661 (2 1/2" NPT-F flange) and P/N F318 (flange blank).)
- B. **1-1/4"-NPT Outlet Ports (2)** Both ports can be connected to the delivery line, depending on the accessories to be installed and inlet line characteristics.
- C. **Oil Drain Plug (1)** (position 36)* Used to empty the crankcase during oil changes. It includes a magnet to collect metal impurities inside the crankcase.

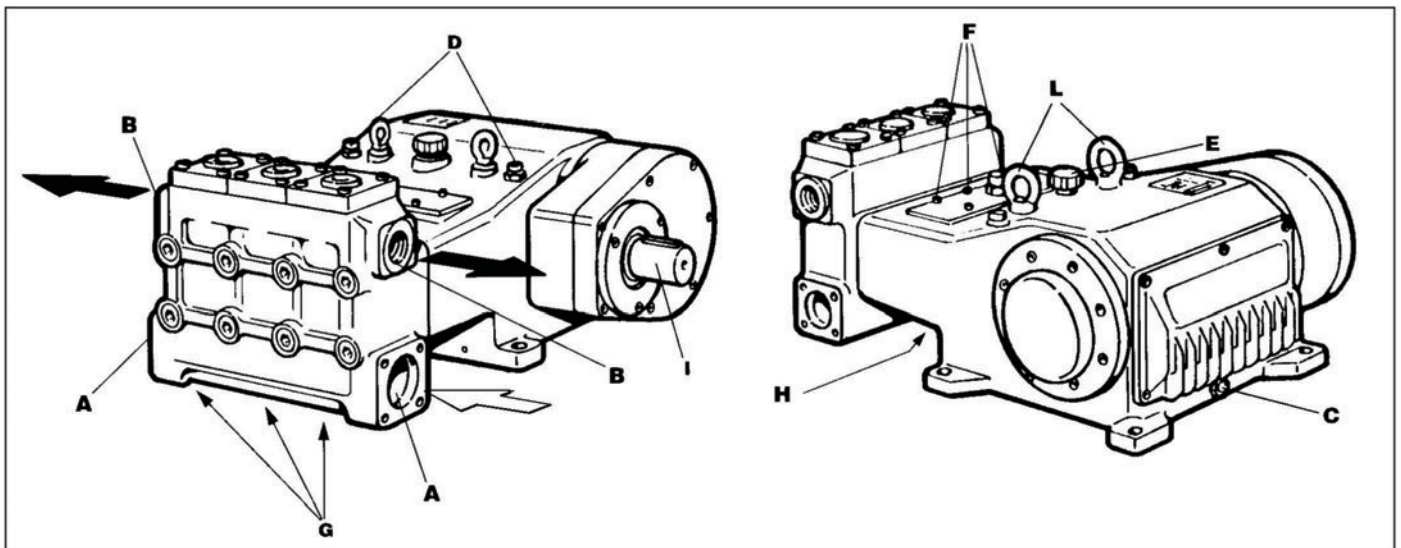

- D. **Oil Dipstick (2)** (position 41) Used to monitor oil level.
- E. **Oil Fill Plug (1)** (position 45) Used to change or add oil.
- F. **Grease Fittings (3)** (position 57) Used to apply grease to the pressure packings.
- G. **Plug (3)** (position 90) Used to remove the valve assembly from its seat if it is stuck due to excessive scaling. Remove plugs and insert a pin to dislodge the valve assembly and push it out.
- H. **1/2"-NPT Drain Hole** (Ref. H, above) Used to drain water from the pressure packing chamber. Always leave this hole open.
- I. **Shaft Extension (1)** 50 MM Dia. with Gearbox
70 MM Dia. w/o Gearbox
- L. **Eyebolts (2).**

*All positions are referenced as shown on the parts breakdown on page 14.

8. PUMP INSTALLATION

8a. Positioning

The pump must be mounted to a rigid and flat base using the four threaded feet in the crankcase.

Be sure maximum pump inclination during operation does not exceed 5° from level in order to guarantee the correct splash lubrication.

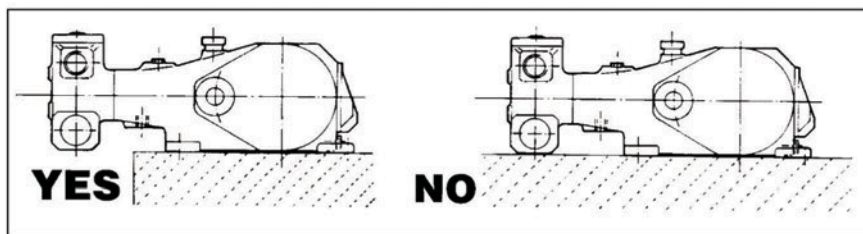

The base must not permit any misalignment or flexing of the pump/transmission coupling.

Never install the pump such that the fluid end rests on the base on which the pump is mounted. The fluid end must be left free and not subject to any force.

8b. Direction of rotation

The diagram at right shows the correct direction of rotation looking at the pump from the **fluid end side**:

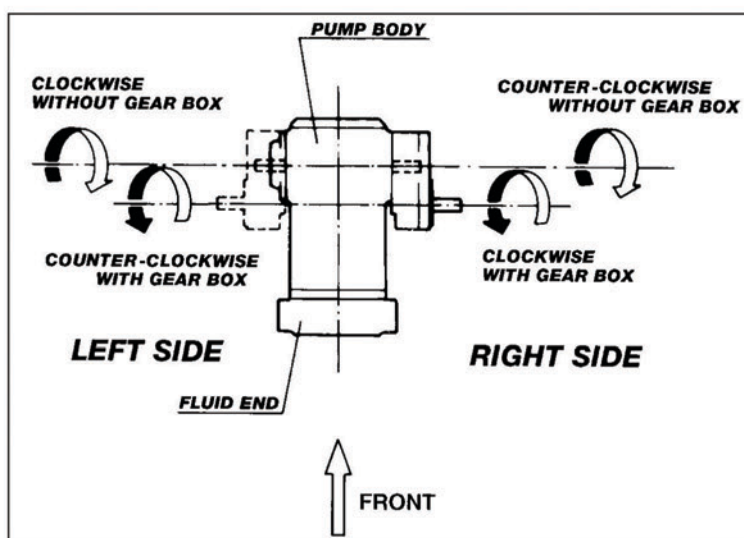

8c. Water line connections

In order to isolate the pump vibration, use flexible hoses for both inlet and discharge lines.

8d. Pump feeding

MSS pumps require an inlet pressure at the inlet port between 15 psi and 45 psi.

The feed pump (centrifugal type) must: (1) supply at least twice the plunger pump volume at the required pressure, (2) operate independently and (3) supply its full rated performance even if the plunger pump is run below its rated performances.

We recommend a pressure switch in the inlet line (after the filters) to prevent the MSS pump from starting until the inlet pressure has reached 15 psi. This pressure switch will also stop the pump in case of filter clogging.

8e. Inlet line

THE INLET LINE **MUST** HAVE THE FOLLOWING CHARACTERISTICS:

- Minimum internal diameter of 66 mm (2.6 in.).
- No bends or changes in diameter within 12 inches of the suction port.
- Be airtight.
- Be completely free of 90° elbows, diameter reductions, counter slopes and T-connections, and must not be connected with other pipelines within 10 diameters of inlet port.
- Be positioned so that it remains filled after the pump stops.

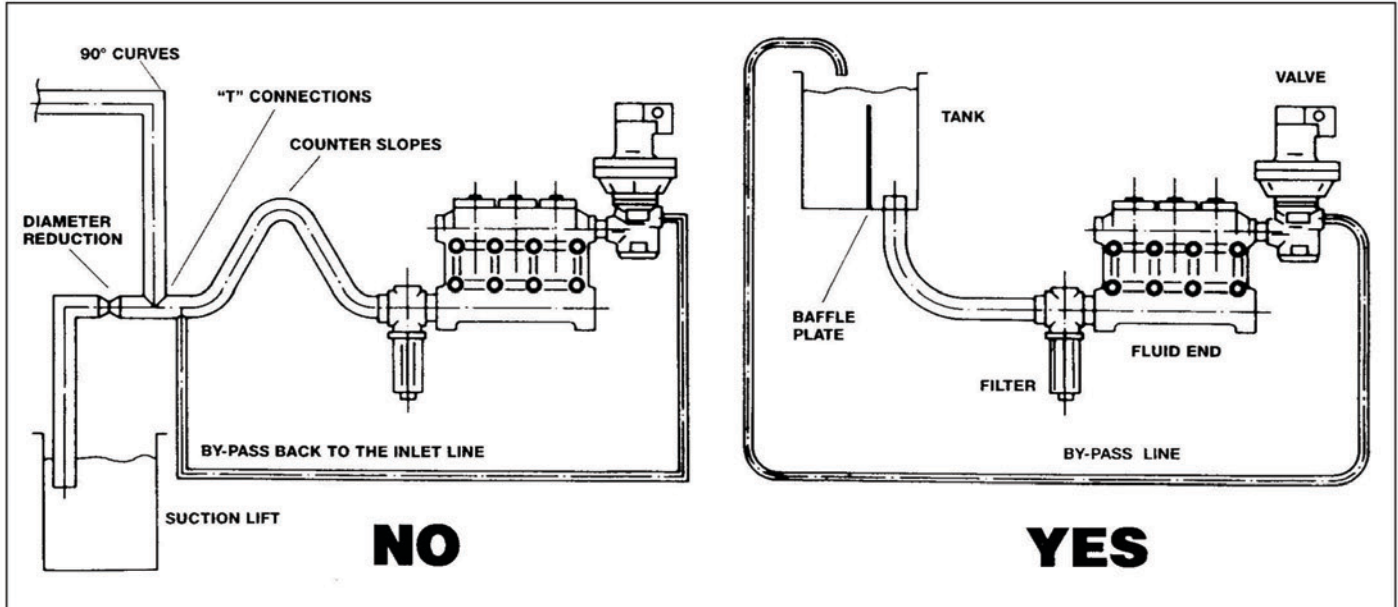

RECOMMENDATIONS:

- Do not connect the bypass line directly to the inlet line.
- Do not use high pressure flexible hose for the inlet line.
- Install the inlet pressure gauge after the filters and as close as possible to the pump inlet port.
- Be sure that the feed pump tank dimensions and the minimum water level do not create turbulence at the pump inlet port. Recommended minimum tank volume is five times discharge flow rate.
- Connect the by-pass directly to the feed tank and be sure that both the by-pass and feed tank flows do not create turbulence at the pump inlet port. Baffle plates should be inside the tank.
- Before connecting the suction line to the pump inlet port be sure the line is clean inside.
- Do not install a chemical injector on the inlet line.

8f. Filtration

MSS pumps require 200 to 360 micron filtration.

The filters should be installed as close as possible to the pump, allow easy inspection and have the following characteristics:

- The capacity of each filter must be at least 3 times the rated pump volume.
- Filter port diameters should not be smaller than the pump inlet ports.

IMPORTANT NOTE: Clean the filters daily, more often in poor water conditions, to prevent premature pump wear and damage.

8g. Discharge line

To ensure the discharge line is correctly installed:

- Install a suitable safety valve on the discharge line.
- Use only high pressure hoses and fittings that exceed the working pressure of the system.
- Use glycerine filled pressure gauges.

9. START-UP AND RUNNING PROCEDURES

9a. Start-up checks

Before starting the pump, be sure that the following conditions have been met:

- Inlet line must be connected, and tight: **the pump must never run dry.**
- All ON-OFF valves in between the pump and water supply must be open. Be sure water flows into the pump.
- Be sure all connections are tight.
- Set the discharge line into the dump mode, to prime the pump.
- Be sure joint alignment, belt tension or U-joint angle is within Manufacturer's specification.
- Check oil level.

NOTE: If pump has not been operated for a long period of time, check the inlet and discharge lines for scaling.

9b. Start-up and operation

- Make sure the correct inlet pressure is provided.
- Do not start pump and motor (or engine) under load. Set the regulating valve to zero or set the discharge line into the dump mode.
- Be sure that the correct inlet pressure is provided.
- Check for proper direction of pump rotation.
- Be sure the rotating speed does not exceed the rated speed.
- Before putting the pump under pressure, let the pump run for some time until the oil flows freely.
- Before stopping the pump, relieve the pressure from the system.

9c. Cooling system

During operation a small amount of water (a few drops a minute) is released from the pump fluid end. This leakage is designed to provide lubrication for the pressure packings. The leakage is drained out of the pump through a hole in the cover (Ref. drawing at right). **Always leave this hole open.**

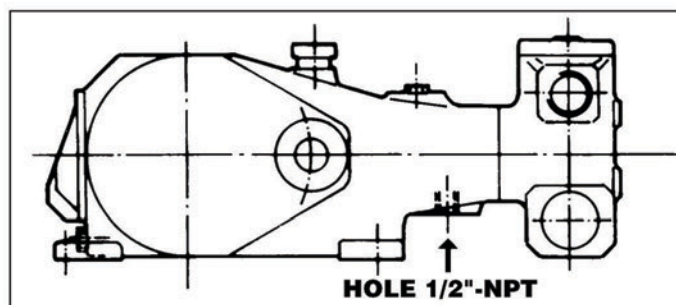

10. MAINTENANCE INSTRUCTIONS

10a. Crank mechanism maintenance

Check the oil level with dipstick (position 41)* frequently. It should be checked on a weekly basis. Oil level should remain between the notches on the dipstick. Stop the pump and provide immediate service if water gets into the oil. Before filling the pump with new oil, wash the crankcase and crank mechanism with a solvent and allow to dry completely. To ease the replacement of the oil seals (position 62) we recommend the use of maintenance tool (p/n F2000.0014.0). Oil seals (position 62) should be replaced every three years.

Change oil after 50 working hours and every 500 working hours thereafter.

The oil must be changed at least once a year.

We recommend you use General Pump oil or its equivalent. (If working at normal room temperature – from 32° to 113° F – use General Pump Series 220 Oil (P/N 100217).)

Pump oil pump capacity is 10.5 quarts with gearbox and 8.5 quarts without gearbox.

During oil changes, the pump oil should be at working temperature; be sure to clean the magnetic plug (position 36) and check the cover (position 27) for grease sediment.

*All positions are referenced as shown on the parts breakdown on page 14.

10b. Fluid end maintenance

The fluid end **does not** require periodic maintenance.

Service operations are limited to valve inspection and/or replacement, when necessary:

- Step 1. Loosen the four valve cover screws (position 72)* and gradually tighten the set screws (position 71) to lift the valve unit and allow extraction by hand.

IMPORTANT NOTE: BEFORE REPOSITIONING THE VALVE UNITS, CLEAN AND DRY ALL VALVE HOUSINGS INSIDE THE MANIFOLD.

- Step 2. Replace each valve assembly. Before repositioning the valve assemblies in the fluid end, unscrew the set screws (position 71) until they reach their initial position.
- Step 3. Replace all valve and valve cover O-rings at every inspection.
- Step 4. Replace valve cover screws (position 72) and tighten the screws to 90 ft.-lbs. in an alternating sequence.

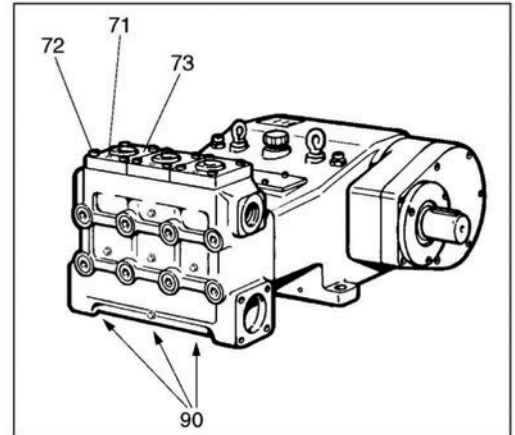

If excessive scaling inside the fluid end prevents valve extraction, open one of the two inlet ports, loosen the three plugs (position 90), insert valve extraction tool (p/n F2000.0005.0) and push the valve unit out as shown.

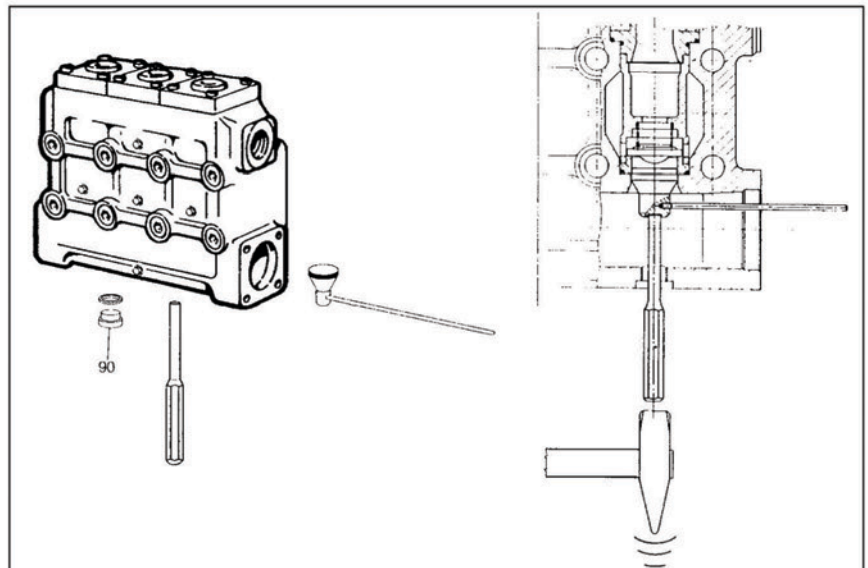

10c. Pressure packings and plungers maintenance

The only maintenance operation required for the pumping system is the pressure packing greasing through the proper greasers (position 57) located on the pump crankcase.

Greasing must be carried out at even intervals at least every 100 working hours by means of a hand pump. Stop greasing when the pump trigger becomes harder to operate: that means the grease chamber is full.

Use General Pump Packing Lubricant (p/n 100278).

Periodically check the amount of water drained out by the pump through the hole provided in the cover (position 27). It clearly shows the pressure packing state of wear; replace packings if water dripping becomes continuous.

*All positions are referenced as shown on the parts breakdown on page 14.

Inspection/replacement of the pumping unit components:

- Step 1. Remove the manifold (position 89) by loosening the eight mounting screws (position 88).
- Step 2. Remove the plunger bolt (position 69) and washer (position 68) and push the plunger forward.
- Step 3. Remove the cover (position 48).
- Step 4. Move piston guide (position 59) backwards by rotating the crankshaft to bottom dead center.
- Step 5. Insert maintenance tool (p/n F2000.3005.0) or a pin of adequate dimensions in between the guide piston and packing support (position 98). By rotating the crankshaft, move the piston guide forward. In turn, the pin will move forward to eject the complete pumping unit.
- Step 6. Split the pumping unit, check the components for wear and replace as necessary. **Always replace the pressure packings.**

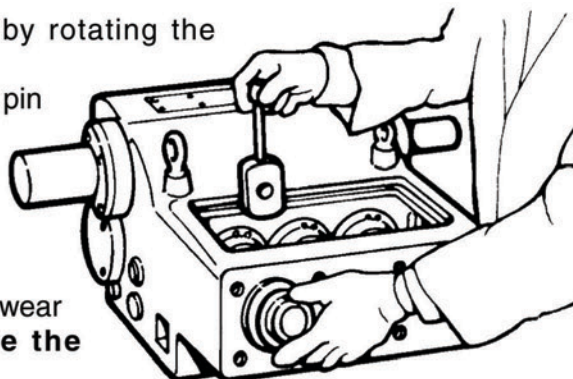

NOTE: The scraper (position 100) features a particular shape on its internal diameter which performs the correct scraping effect only if fitted in the correct position, as shown.

- Step 7. To fit the scraper in place, shape it with your fingers as shown. Once in place, seat the scraper with your fingers.
- Step 8. When replacing the pressure packings, apply a very small quantity of silicone grease on their lips to ease assembly.
- Step 9. Replace all O-rings of the pumping unit.
- Step 10. Set up the complete pumping unit and install it in the pump in one single block. The scraper (position 100) must be in the correct position.
- Step 11. Tighten the plunger screws (position 69) to 72 ft.-lbs. The washer (position 68) should always be replaced.
- Step 12. Install the manifold and tighten the screws (position 88) to 180 ft.-lbs. in an alternating sequence as shown.
- Step 13. Grease the pumping units through the grease fittings (position 57).

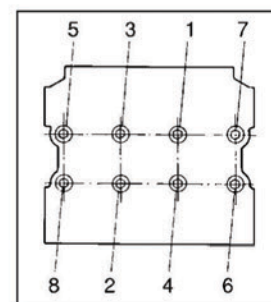
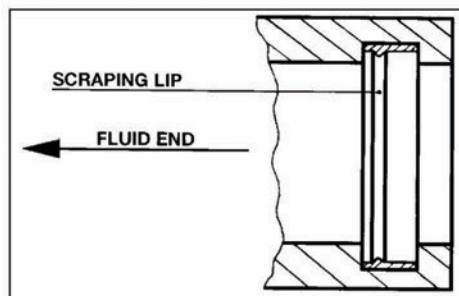

10d. Fastener torque values

Always use a torque wrench:

POSITION*	DESCRIPTION	Kgm	Nm	Ft-lbs
72	Valve cover screws	12.5	123	90
88	Manifold screws	25	245	180
69	Plunger screws	10	98	72
23	Connecting rod screws	7	68	50

*All positions are referenced as shown on the parts breakdown on page 14.

11. PUMP STOPPED FOR LONG PERIOD

Before starting the pump after a long period of inactivity: (1) check for correct oil level, (2) check the valves as indicated in section 10b and (3) use the starting procedures indicated in section 9.

When a long period of inactivity is scheduled, drain the entire suction and delivery line and run the pump for a few seconds to drain out all water.

12. FROST PRECAUTIONS

When there is risk of freezing:

- Drain all suction and delivery lines (filter included).
- Run the pump for a few seconds to drain the water collected inside the manifold. Flush the system with a 50-percent solution of anti-freeze until the anti-freeze works throughout the system.

WARNING: If a pump is frozen or appears frozen **DO NOT OPERATE THE PUMP** until the entire system has been thawed.

13. MSS Models

Installation, use and maintenance instructions for these models are the same as the standard ones. For the MSN versions, rinse with pure water after use.

Torque values for MSS models

Tighten screws using a torque wrench.

POSITION*	DESCRIPTION	Kgm	Nm	Ft-lbs
72	Valve cover screws	12.5	123	90
88	Manifold screws	25	245	180
69	Plunger screws	8	79	58
23	Connecting rod screws	7	68	50

*All positions are referenced as shown on the parts breakdown on page 14.

10e. Parts breakdown

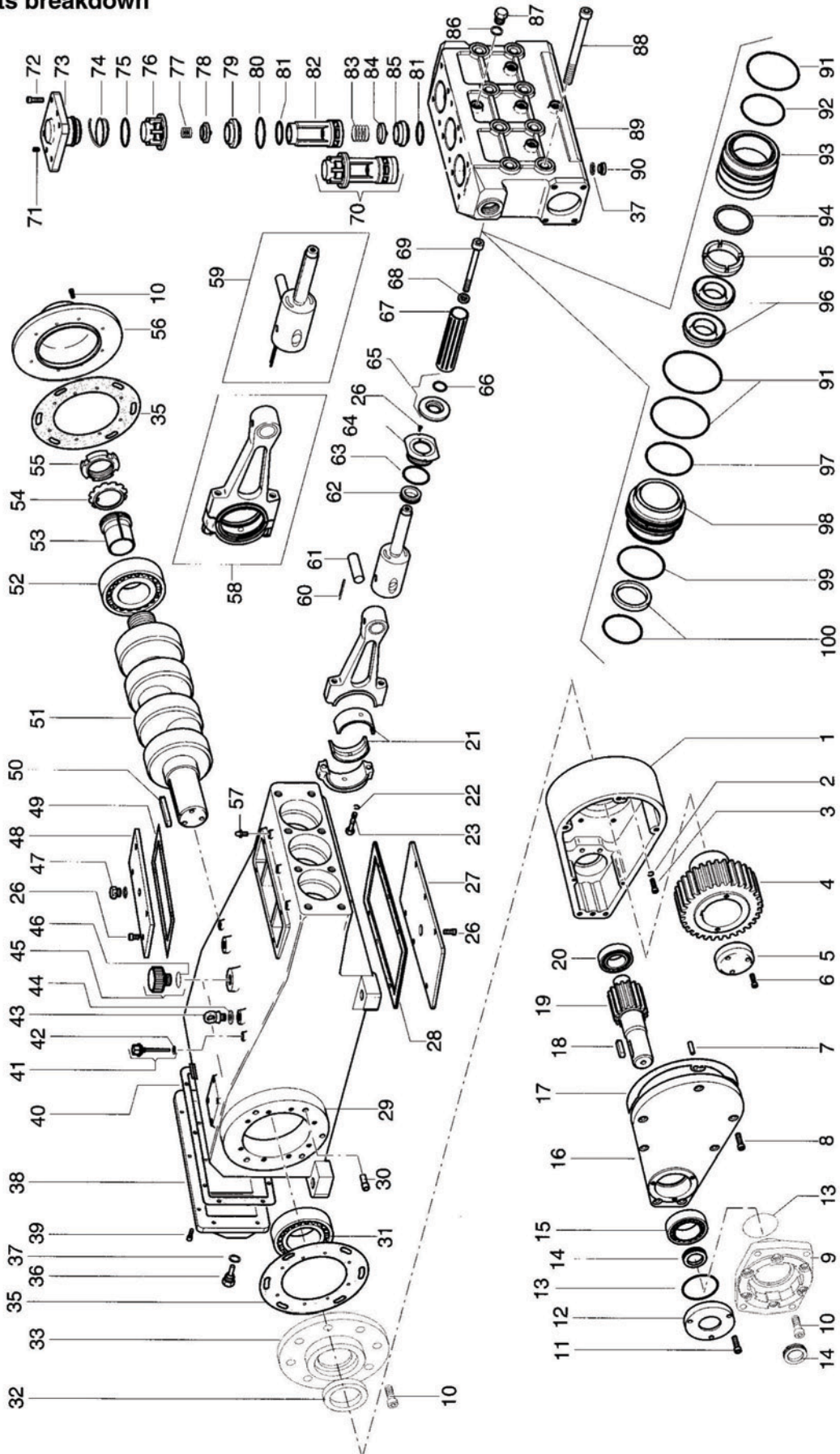

MSS SERIES PARTS

Pos.	Code	Description	Kit Qty.	Pos.	Code	Description	Kit Qty.	Pos.	Code	Description	Kit Qty.
1	F060100240	*Reduction Gear Housing	1	44	F030000030	*Eyebolt Lining	2/4	84	F082200100	Suction Valve Plate	3
2	F872047005	Washer 10	8	45	F8010540027	Cap Filling G1"	1	85	F081200120	Suction Valve Seat	3
3	F871125108	Screw M10 x 40	8	46	F881010116	O-Ring 29.62 x 2.62	C	86	F872041300	Washer 1/4"	5
4	F052000100	Gear Ring 1500 RPM (Z 55)	1	47	F0010566002	Breathing Cap G 1/2"	1	87	F821201051	*Plug G 1/4" BSP-M	C
5	F052000120	Gear Ring 1800 RPM (Z 58)	1	48	F040000050	*Upper Cover	1	88	F871145120	*Screw M18 x 180	8
6	F030000090	Flange Locking Gear Ring	3	49	F080600120	Top Gasket Cover	C	89	F064100260	*Manifold	1
7	F871125105	Screw M10 x 25	3	50	F872012070	*Key 20 x 12 x 70	1	90	F084000010	Cap G 1/2" NK	3
8	F872126004	*Cylinder Pin 12 x 40	2	51	F050000100	*Crankshaft 60 mm	1	91	F881011052	O-Ring 78 x 2	1
9	F871125110	*Screw M10 x 50	7	52	F811112008	*Needle Bearing	1	92	F881011164	O-Ring 62 x 3	A-C
10	F010100010	*Hydraulic Motor Flange	1	53	F811920004	*Pressure Sleeve	1	93	F062200220	Sleeve MS 36-40	A-C
11	F871125154	Screw M10 x 30	8-14-16	54	F872069012	Washer NB12	C	F062200230	*Sleeve MS 45	3	
12	F871125153	Screw M10 x 25	3	55	F872020020	Ring Nut KM12	1	F062200240	*Sleeve MS 50	3	
13	F063100190	*Reduction Gear Flange	1	56	F063400580	Bearing Cover	1	F062200250	Sleeve MS 55	3	
14	F881010131	O-Ring 113.97 x 2.62	C	57	F801077003	Lubrication M 10x1	C	F031300020	Spring Loaded Spacer MS 36-40	3	
15	F881080026	Shaft Seal 55 x 75 x 10	C	58	F250000020	Complete Connecting Rod	3	F031300120	*Spring Loaded Spacer MS 45	3	
16	F811110010	Needle Bearing	1	59	F250001060	*Complete Piston	3	F031300050	*Spring Loaded Spacer MS 50	3	
17	F063100150	*Reduction Gear Cover	1	60	F872142015	Elastic Pin 5 x 36	C	F031300060	*Spring Loaded Spacer MS 55	3	
18	F080600140	Reduction Gear Gasket	C	61	F071000060	Piston Pin 28MS	C	F031200090	*Gasket Seal Ring MS 36	3	
19	F872097009	Key 14 x 9 x 60	1	62	F881081000	Piston Shaft Seal 32 x 45 x 6.5	C	F031200100	*Gasket Seal Ring MS 40	3	
20	F872097013	*Key 14 x 9 x 60	1	63	F881010127	O-Ring 64.77x 2.62	C	F031200110	Gasket Seal Ring MS 45	3	
21	F052000110	Pinion 1500 RPM (Z 27)	1	64	F063400560	Piston Oil Seal Cover	3	F031200210	*Gasket Seal Ring MS 50	3	
22	F052000130	Pinion 1800 RPM (Z 24)	1	65	F205000000	Guard with O-Ring	3	F031200220	Gasket Seal Ring MS 55	3	
23	F052000180	Pinion 1500 RPM (Z 27)	1	66	F881012115	O-Ring 26.65 x 2.62	A-C	F881020010	Pressure Gasket MS 36	A-C	
24	F052000210	Pinion 1800 RPM (Z 24)	1	67	F024200340	Plunger MS 36	3	F881020012	Pressure Gasket MS 40	A-C	
25	F811110002	Roller Bearing	1	68	F024200350	*Plunger MS 40	3	F881020014	Pressure Gasket MS 45	A-C	
26	F812000001	Brass Head Connecting Rod	3	69	F024200360	*Plunger MS 45	3	F881020015	Pressure Gasket MS 50	A-C	
27	F872046006	Washer 12	6	70	F024200370	*Plunger MS 50	3	F881020016	Pressure Gasket MS 55	A-C	
28	F035000070	Connecting Rod Screw	C	71	F024200380	Plunger MS 55	3	F881011161	O-Ring 56 x 3 MS 36-40	A-C	
29	F871115152	Screw M6 x 14	16	72	F871135103	Washer 14 - Special	A-C	F881011163	O-Ring 59.5 x 3 MS 45	A-C	
30	F040000070	*Lower Cover	1	73	F871355116	Hex Socket Screw M14 x 120 MS 36-40-45	3	F881011165	O-Ring 65 x 3 MS 50	A-C	
31	F080600130	Lower Gasket Cover	C	74	F871355110	Hex Socket Screw M14 x 80 MS 50-55	3	F881011167	O-Ring 69.5 x 3 MS 55	A-C	
32	F034000010	*Reference Shaft	1	75	F022300340	Valve Assembly	3	F022300350	*Gasket Holder MS 36	3	
33	F034000016	*Needle Bearing	1	76	F871135103	Headless Screw M10 x 25	6	F022300360	Gasket Holder MS 40	3	
34	F063400640	*Direct Drive Bearing Cover	1	77	F063100110	Screw M14 x 45	12	F022300370	Gasket Holder MS 45	3	
35	F881080032	Shaft Seal 70 x 90 x 10	1	78	F082200110	Valve Cover	3	F022300380	Gasket Holder MS 50	3	
36	F080600110	Bearing Cover Gasket	C	79	F881120022	Anti-Extrusion Ring	B-C	F022300390	Gasket Holder MS 55	3	
37	F872043002	*Magnetic Cap G 1/2"	4	80	F881010219	O-Ring 65.09 x 3.53	B-C	F881010127	O-Ring 64.77 x 2.62 MS 36-40-45-50	A-C	
38	F063400540	*Back Cover	1	81	F021300110	Expanded Guide Valve	3	F881010014	O-Ring 66.40 x 1.78 MS 55	A-C	
39	F871121152	Screw M6 x 20	6	82	F090200090	Valve Spring Head	3	F881061014	Scraper MS 36	A-C	
40	F080600100	Back Gasket Cover	C	83	F082200130	Valve Plate Head	3	F881061015	Scraper MS 40	A-C	
41	F001000010	*Oil Level Rod	2	84	F081200130	Delivery Valve Seat	3	F881061017	Scraper MS 45	A-C	
42	F872041501	*Washer 3/8"	C	85	F881011166	O-Ring 66 x 3	B-C	F881061018	Scraper MS 50	A-C	
43	F872026003	Eyebolt M16	2	86	F021300090	Suction Valve Guide	6	F881061019	Scraper MS 55	A-C	

* Special Order

REPAIR KITS

GROUP	ITEM	MSS 36	MSS 40	MSS 45	MSS 50	MSS 55
A	66-68-91-92-96-97-99-100	F1134	F1135	F1136	F1137	F1138
B	37-74-75-80-81	F1139				
C	2-13-14-17-22-28-35-37-40-42 46-49-54-57-60-62-63-66-68 74-75-80-81-86-91-92-96-97 99-100	F1140	F1141	F1142	F1143	F1144

TORQUE SPECS

Position	Ft.-lbs.
23	50
69	72
88	180
72	90

MAINTENANCE LOG**HOURS & DATE**

Oil Change							
Grease							
Packing Replacement							
Plunger Replacement							
Valve Replacement							

**GP Companies, Inc.**

1174 Northland Drive
Mendota Heights, Minnesota 55120
(651)686-2199 • Fax: (800)535-1745

Ref 300522 Rev. A
06-05

Email: sales@gpcompanies.com www.generalpump.com