

LWD VERSION - 3400 RPM

ITEM	PART No.	KIT	DESCRIPTION	Qty.	MODELS
35	3201.0010.00		OIL INDICATOR	1	
36	1210.0333.00	D	O-RING 1,78X23,52 mm	1	
37	1210.0206.00	D	O-RING 2,62X101,27 mm	1	
38	0402.0142.00		CRANKCASE COVER	1	
39	3609.0041.00		SCREW M6X25	4	
46	1210.0441.00	D	O-RING 2X14 mm	1	
47	3200.0007.00		CAP 3/8GAS OT58	1	
48	3200.0007.00		CAP 3/8GAS OT58	1	
49	2811.0084.00		WASHER 16,7X22X1,5 mm	1	
50	3202.0015.00		CAP G1/2	1	
51	2811.0086.00		WASHER 21,2X27X1,5 mm	1	
61	1220.0030.00		VALVE ASS. BLY.	6	

E version

ITEM	PART No.	KIT	DESCRIPTION	Qty.	MODELS
52	3609.0032.00		SCREW M6X20	4	
53	3016.0016.00		FLANGE	1	
54	3607.0200.00		SCREW 3/8"16X3/4"	4	
55	0019.0075.00	D	OIL SEAL 35X62X 7 mm	1	
56	3019.0004.00		SNAP RING C72	1	
57	3020.0012.00		SNAP RING C72	1	
58	2812.0064.00		WASHER	1	
59	0438.0015.00		BALL BEARING 35X62X14 mm	1	
60	0001.0336.00		CRANKSHAFT 5/8"	1	2010 E - 2015 E 2020 E
	0001.0337.00		CRANKSHAFT 5/8"	1	3010 E - 3015 E 3020 E

S version

ITEM	PART No.	KIT	DESCRIPTION	Qty.	MODELS
40	0019.0094.00	D	OIL SEAL 25X62X10/7 mm	1	
41	3019.0006.00		SNAP RING C72	1	
42	3020.0012.00		SNAP RING C72	1	
43	0438.0071.00		BALL BEARING 25X62X17 mm	1	3025 S - 3522 S 4020 S
	0438.0075.00		BALL BEARING 25X62X17 mm	1	2010 S - 2015 S 2020 S - 3010 S 3015 S - 3020 S
44	1602.0045.00		KEY 8X7X25 mm	1	
45	0001.0286.00		CRANKSHAFT Ø24 mm	1	2010 S - 2015 S 2020 S
	0001.0288.00		CRANKSHAFT Ø24 mm	1	3522 S
	0001.0332.00		CRANKSHAFT Ø24 mm	1	3010 S - 3015 S 3020 S - 3025 S
	0001.0333.00		CRANKSHAFT Ø24 mm	1	4020 S

G version

ITEM	PART No.	KIT	DESCRIPTION	Qty.	MODELS
63	3016.0012.00		FLANGE	1	
64	3607.0199.00		SCREW 5/16"24X3/4"	4	
65	0019.0075.00	D	OIL SEAL 35X62X 7 mm	1	
66	3019.0004.00		SNAP RING C72	1	
67	3020.0012.00		SNAP RING C72	1	
68	2812.0064.00		WASHER	1	
69	0438.0015.00		BALL BEARING 35X62X14 mm	1	2010 G - 2015 G 2020 G - 2520 G 3010 G - 3015 G 3020 G - 3515 G
	0438.0070.00		BALL BEARING 35X62X14 mm	1	2525 G - 3025 G 3522 G - 4020 G
70	0001.0334.00		CRANKSHAFT 3/4"	1	2010 G - 2015 G 2020 G
	0001.0335.00		CRANKSHAFT 3/4"	1	3010 G - 3015 G 3020 G - 3025 G
	0001.0383.00		CRANKSHAFT 3/4"	1	3515 G - 3522 G
	0001.0384.00		CRANKSHAFT 3/4"	1	4020 G
	0001.0406.00		CRANKSHAFT 3/4"	1	2520 G - 2525 G

COMPLETE VALVE KIT
5025.0011.00

KIT A

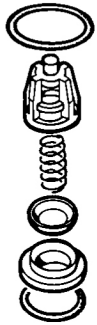

5025.0011.00

ITEM	PART No.	Qty.
4	1210.0046.00	6
5	3009.0087.00	6
6	3604.0017.00	6
7	1802.0177.00	6
8	1205.0025.00	6
9	1210.0048.00	6

PISTON SEAL KIT
Ø 15 mm 5019.0035.00

KIT B

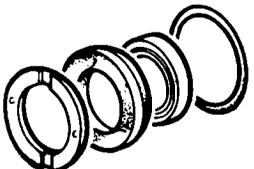

5019.0035.00

ITEM	PART No.	Qty.
20	0009.0196.00	3
21	1241.0034.00	3
22	1241.0030.00	3
24	1210.0223.00	3

PISTON KIT
Ø 15 mm 2409.0071.00

KIT C

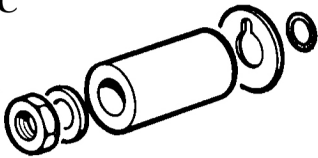

2409.0071.00

ITEM	PART No.	Qty.
26	0600.0048.00	3
27	2811.0080.00	3
28	0202.0020.00	3
29	2812.0038.00	3
30	1210.0055.00	3

5019.0040.00			5019.0041.00		
ITEM	PART No.	Qty.	ITEM	PART No.	Qty.
4	1210.0046.00	6	4	1210.0046.00	6
9	1210.0048.00	6	9	1210.0048.00	6
14	1210.0386.00	1	14	1210.0386.00	1
24	1210.0223.00	3	24	1210.0223.00	3
25	0019.0095.00	3	25	0019.0095.00	3
30	1210.0055.00	3	30	1210.0055.00	3
36	1210.0333.00	1	36	1210.0333.00	1
37	1210.0206.00	1	37	1210.0206.00	1
40	0019.0094.00	1	46	1210.0441.00	1
46	1210.0441.00	1	55-65	0019.0075.00	1

SEAL KIT
SOLID SHAFT 5019.0040.00
HOLLOW SHAFT 5019.0041.00

KIT D

