

LW VERSION - 1450 RPM

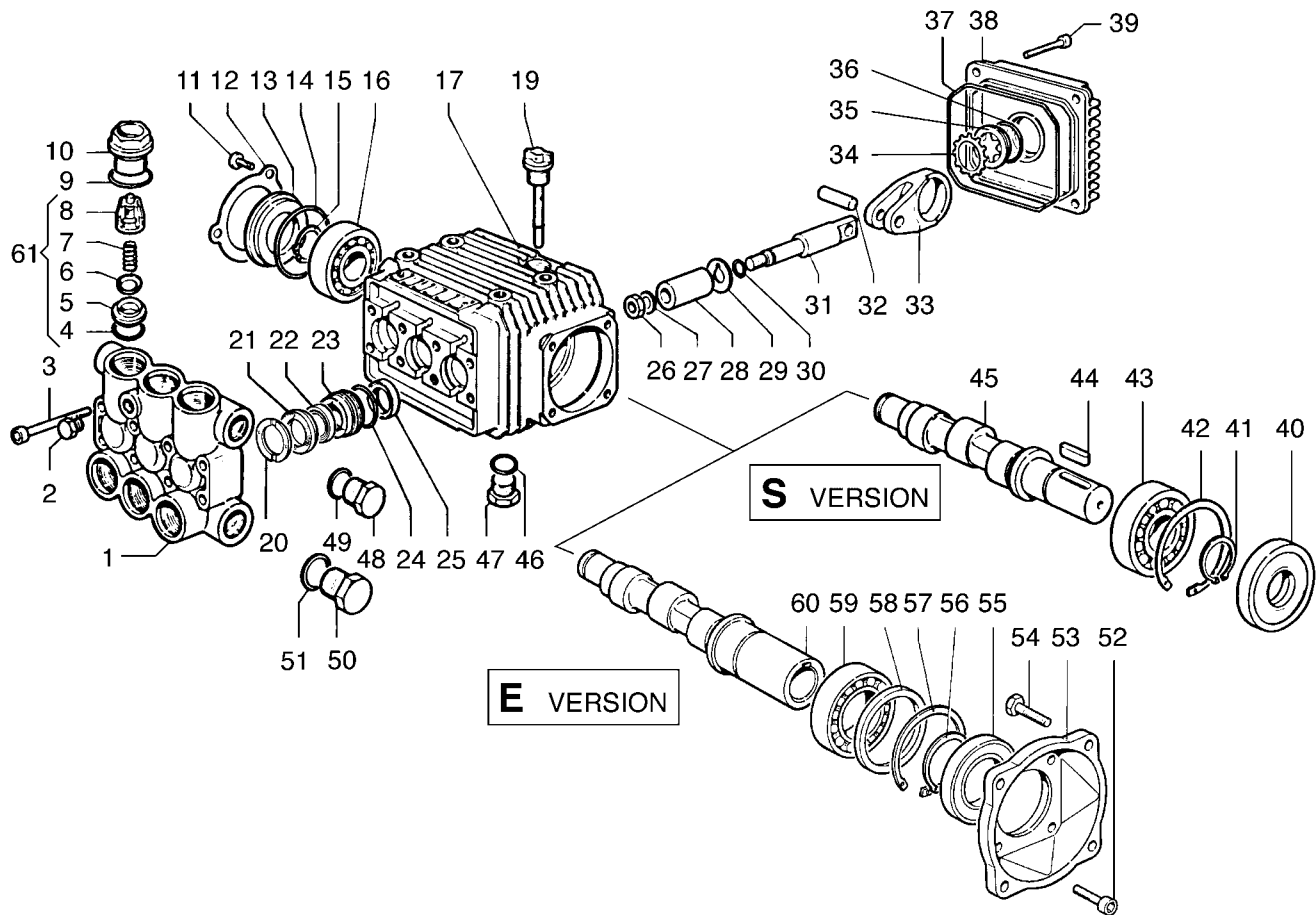

POS. ITEM	CODICE PART No.	KIT KIT	DESCRIZIONE DESCRIPTION	Q.tà Qty.	MODELLI MODELS
1	3218.0105.00		MANIFOLD Ø 18 mm ALUM.	1	3016 S - 3016 E 3513 S - 3513 E
	3218.0106.00		MANIFOLD Ø 15 mm ALUM.	1	2015 S - 2015 E
	3218.0107.00		MANIFOLD Ø 18 mm BRASS	1	3016 S - 3016 E 3020 S - 3025 S 3513 S - 3513 E 3517 S - 3525 S 2520 S
	3218.0108.00		MANIFOLD Ø 15 mm BRASS	1	2015 S - 2015 E 2020 S - 2020 E
2	3202.0018.00		CAP G1/8	1	
3	3609.0108.00		SCREW M6X55	8	2015 S - 2015 E 2020 S - 2020 E 3016 S - 3016 E 3020 S - 3517 S 3513 S - 3513 E 2520 S
	3609.0152.00		SCREW M6X55	8	3025 S - 3525 S
4	1210.0046.00	A-D	O-RING 2,62X17,13 mm	6	
5	3009.0087.00	A	VALVE SEAT	6	
6	3604.0017.00	A	VALVE PLATE	6	
7	1802.0177.00	A	SPRING	6	
8	1205.0025.00	A	VALVE GUIDE	6	
9	1210.0048.00	A-D	O-RING 2,62X20,24 mm	6	
10	3202.0155.00		CAP	6	
11	3609.0088.00		SCREW M5X10	3	
12	1004.0012.00		CRANKCASE COVER	1	
13	0402.0172.00		SPACER	1	
14	1210.0386.00	D	O-RING 3,53X44,04 mm	1	
15	3019.0011.00		SNAP RING	1	
16	0438.0066.00		BALL BEARING 20X52X15 mm	1	2015 S - 2015 E 2020 S - 2020 E 3016 S - 3016 E 3020 S - 3517 S 3513 S - 3513 E 2520 S
	0438.0069.00		BALL BEARING 20X52X15 mm	1	3025 S - 3525 S

POS. ITEM	CODICE PART No.	KIT KIT	DESCRIZIONE DESCRIPTION	Q.tà Qty.	MODELLI MODELS
17	0403.0128.00		CRANKCASE	1	
19	3200.0051.00		OIL DIPSTICK	1	
20	0009.0196.00	B	HEAD RING Ø 15 mm	3	2015 S - 2015 E 2020 S - 2020 E
	0009.0193.00	B	HEAD RING Ø 18 mm	3	3016 S - 3016 E 3020 S - 3025 S 3513 S - 3513 E 3517 S - 3525 S 2520 S
21	1241.0034.00	B	PACKING Ø 15 mm	3	2015 S - 2015 E 2020 S - 2020 E
	1241.0035.00	B	PACKING Ø 18 mm	3	3016 S - 3016 E 3020 S - 3025 S 3513 S - 3513 E 3517 S - 3525 S 2520 S
22	1241.0030.00	B	PACKING 15X22X5,5 mm	3	2015 S - 2015 E 2020 S - 2020 E
	1241.0028.00	B	PACKING 18X25X5,5 mm	3	3016 S - 3016 E 3020 S - 3517 S 3513 S - 3513 E 2520 S - 3025 S 3525 S
23	0009.0198.00		PACKING RETAINER Ø15 mm	3	2015 S - 2015 E 2020 S - 2020 E
	0009.0197.00		PACKING RETAINER Ø 18 mm	3	3016 S - 3016 E 3020 S - 3517 S 3513 S - 3513 E 2520 S - 3025 S 3525 S
24	1210.0223.00	B-D	O-RING 1,78X26,7 mm	3	
25	0019.0095.00	D	OIL SEAL 15X24X5 mm	3	
26	0600.0048.00	C	NUT	3	
27	2811.0080.00	C	WASHER 8,2X14X1,5 mm	3	

LW VERSION - 1450 RPM

POS. ITEM	CODICE PART No.	KIT KIT	DESCRIZIONE DESCRIPTION	Q.tà Qty.	MODELLI MODELS
28	0202.0018.00	C	PISTON Ø18 mm	3	3016 S - 3016 E 3020 S - 3025 S 3513 S - 3513 E 3517 S - 3525 S 2520 S
	0202.0020.00	C	PISTON Ø 15 mm	3	2015 S - 2015 E 2020 S - 2020 E
29	2812.0038.00	C	WASHER	3	
30	1210.0055.00	C-D	O-RING 1,78X 6,07 mm	3	
31	2409.0044.00		PISTON GUIDES	3	
32	3011.0014.00		WRIST. PIN	3	
33	0205.0048.00		CON. ROD	3	2020 S - 2020 E 2015 S - 2015 E 3513 S - 3513 E
	0205.0050.00		CON. ROD	3	3016 S - 3016 E 3020 S - 3025 S 3517 S - 3525 S 2520 S
34	3019.0033.00		SNAP RING Ø 18 mm	1	
35	3201.0010.00		OIL INDICATOR	1	
36	1210.0333.00	D	O-RING 1,78X23,52 mm	1	
37	1210.0206.00	D	O-RING 2,62X101,27 mm	1	
38	0402.0142.00		CRANKCASE COVER	1	
39	3609.0041.00		SCREW M6X25	4	
46	1210.0441.00	D	O-RING 2X14 mm	1	
47	3200.0007.00		CAP 3/8 GAS OT58	1	
48	3200.0007.00		CAP 3/8 GAS OT58	1	
49	2811.0084.00		WASHER 16,7X22X1,5 mm	1	
50	3202.0015.00		CAP G1/2	1	
51	2811.0086.00		WASHER 21,2X27X1,5 mm	1	
61	1220.0030.00		VALVE ASS.BLY.	6	

S version

POS. ITEM	CODICE PART No.	KIT KIT	DESCRIZIONE DESCRIPTION	Q.tà Qty.	MODELLI MODELS
40	0019.0094.00	D	OIL SEAL 25X62X10/7 mm	1	
41	3019.0006.00		SNAP RING C72	1	
42	3020.0012.00		SNAP RING C72	1	
43	0438.0071.00		BALL BEARING 25X62X17 mm	1	3025 S - 3525 S
	0438.0075.00		BALL BEARING 25X62X17 mm	1	2015 S - 2020 S 3016 S - 3020 S 3513 S - 3517 S 2520 S
44	1602.0045.00		KEY 8X7X25 mm	1	
45	0001.0290.00		CRANKSHAFT Ø24 mm	1	2015 S - 2020 S 3016 S - 3020 S 3025 S
	0001.0294.00		CRANKSHAFT Ø24 mm	1	3513 S - 3517 S 3525 S
	0001.0333.00		CRANKSHAFT Ø24 mm	1	2520 S

E version

POS. ITEM	CODICE PART No.	KIT KIT	DESCRIZIONE DESCRIPTION	Q.tà Qty.	MODELLI MODELS
52	3609.0032.00		SCREW M6 X 20	4	
53	3016.0014.00		FLANGE	1	
54	3607.0015.00		SCREW M8 X 20	4	
55	0019.0075.00	D	OIL SEAL 35X62X7 mm	1	
56	3019.0004.00		SNAP RING Ø 35 mm	1	
57	3020.0012.00		SNAP RING Ø 62 mm	1	
58	2812.0064.00		WASHER	1	
59	0438.0015.00		BALL BEARING 35X62X14 mm	1	
60	0001.0342.00		CRANKSHAFT Ø24 mm	1	2015 E - 2020 E
	0001.0343.00		CRANKSHAFT Ø24 mm	1	3513 E

KIT VALVOLA ASP.-MAND. COMPLETE VALVE KIT 5025.0011.00

KIT A

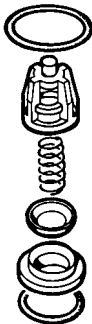

5025.0011.00

POS. ITEM	CODICE PART No.	Q.tà Qty.
4	1210.0046.00	6
5	3009.0087.00	6
6	3604.0017.00	6
7	1802.0177.00	6
8	1205.0025.00	6
9	1210.0048.00	6

KIT GUARNIZIONI PISTONE / PISTON SEAL KIT Ø 15 mm 5019.0035.00 - Ø 18 mm 5019.0037.00

KIT B

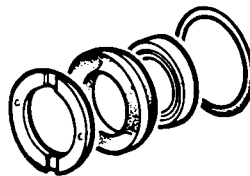

5019.0035.00			5019.0037.00		
POS. ITEM	CODICE PART No.	Q.tà Qty.	POS. ITEM	CODICE PART No.	Q.tà Qty.
20	0009.0196.00	3	20	0009.0193.00	3
21	1241.0034.00	3	21	1241.0035.00	3
22	1241.0030.00	3	22	1241.0028.00	3
24	1210.0223.00	3	24	1210.0223.00	3

KIT PISTONE / PISTON KIT Ø 15 mm 2409.0071.00 - Ø 18 mm 2409.0072.00

KIT C

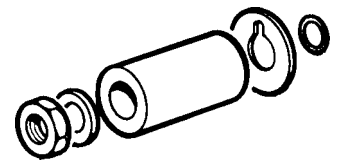

2409.0071.00			2409.0072.00		
POS. ITEM	CODICE PART No.	Q.tà Qty.	POS. ITEM	CODICE PART No.	Q.tà Qty.
26	0600.0048.00	3	26	0600.0048.00	3
27	2811.0080.00	3	27	2811.0080.00	3
28	0202.0020.00	3	28	0202.0018.00	3
29	2812.0038.00	3	29	2812.0038.00	3
30	1210.0055.00	3	30	1210.0055.00	3

KIT GUARNIZIONI POMPA / SEAL KIT ALBERO MASCHIO / SOLID SHAFT 5019.0040.00 ALBERO FEMMINA / HOLLOW SHAFT 5019.0041.00

KIT D

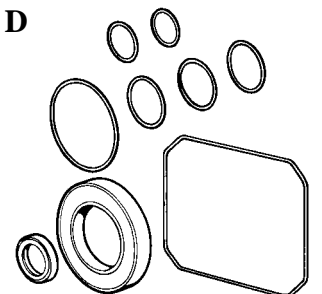

5019.0040.00			5019.0041.00		
POS. ITEM	CODICE PART No.	Q.tà Qty.	POS. ITEM	CODICE PART No.	Q.tà Qty.
4	1210.0046.00	6	4	1210.0046.00	6
9	1210.0048.00	6	9	1210.0048.00	6
14	1210.0386.00	1	14	1210.0386.00	1
24	1210.0223.00	3	24	1210.0223.00	3
25	0019.0095.00	3	25	0019.0095.00	3
30	1210.0055.00	3	30	1210.0055.00	3
36	1210.0333.00	1	36	1210.0333.00	1
37	1210.0206.00	1	37	1210.0206.00	1
40	0019.0094.00	1	46	1210.0441.00	1
46	1210.0441.00	1	55	0019.0075.00	1

Altri KIT
Other KITS

vedi pagine:
see pages:
54 - 55