



HID

Owner's Manual

- *Installation*
- *Use*
- *Maintenance*



INDEX

page

1. INTRODUCTION	1
2. GENERAL WARNINGS FOR SAFE OPERATION	1
a. Fluid injection hazard	1
b. Fuel and emission hazards: engine driven products	2
c. Grounding instructions: motor driven products	2
d. Extension cords: motor driven products	3
e. Equipment misuse hazard	3
f. Hose safety	4
g. Moving parts hazard	4
h. Terms	4
3. PUMP IDENTIFICATION	5
4. TECHNICAL FEATURES	5
5. CONSTRUCTION FEATURES	6
6. GENERAL INFORMATION ON PUMP USE	6–7
a. Water temperature	6
b. Pump performance	7
7. CONNECTIONS AND PLUGS	7
8. PUMP INSTALLATION	8–10
a. Positioning	8
b. Direction of rotation	8
c. Hydraulic connections	8
d. Pump feeding	8
e. Suction line	8–9
f. Filtration	9
g. Delivery line	10
9. START-UP AND RUNNING PROCEDURES	9
a. Start-up checks	9
b. Start-up and operation	9
c. Cooling system	9
10. MAINTENANCE INSTRUCTIONS	10–17
a. Crank mechanism maintenance	10
b. Fluid end maintenance	11
c. Pressure packings and plunger maintenance	11
d. Fastener torque values	12
e. Parts breakdown	14–17
11. PUMP STOPPED FOR LONG PERIOD	13
12. FROST PRECAUTIONS	13
13. HDN MODELS	13

1. INTRODUCTION

The General Pump HD series of high pressure plunger pumps have been designed for long life. They will provide a long period of trouble free operation, if they are correctly installed and maintained.

Read this manual carefully before using your pump. It contains necessary information for correct installation, use and maintenance, and practical trouble shooting suggestions.

2. GENERAL WARNINGS FOR SAFE OPERATION



WARNING: The misuse of a high pressure water unit and improper pump installation and maintenance increases the risk of personal injury and serious damage to the equipment.



WARNING: High pressure spray can cause serious injury. For professional use only. Observe all warnings.



WARNING: Read and understand all instruction manuals before operating equipment.

2a. Fluid injection hazard

General safety

This pump generates very high fluid pressure. Spray from a gun, leaks or ruptured components can inject fluid through your skin and into your body and cause extremely serious bodily injury including the need for amputation. Also, fluid injected or splashed into the eyes or on the skin can cause serious damage.

- **Never** point the spray gun or wand at anyone or at any part of the body. **Never** put hand or fingers over the spray tip.
- **Always** relieve system pressure before cleaning or servicing any part of the system.
- **Never** try to stop or deflect leaks with your hand or body.
- Be sure all equipment safety devices are operating properly before each use.
- **Always** install a pressure relief valve sized to discharge (bypass) 110% of the maximum pump flow rate.
- Protect all components from environmental damage and high pressure water spray.
- **Always** restrict access to the area to properly trained and required personnel.
- Keep the area clear of debris and loose items.
- **Always** use only genuine General Pump replacement parts when servicing the pump.

Medical treatment

If any fluid appears to penetrate your skin, get **EMERGENCY MEDICAL TREATMENT AT ONCE. DO NOT TREAT AS A SIMPLE CUT.** Tell the doctor exactly what fluid was injected.

NOTE

NOTE TO PHYSICIAN: *Injection in the skin is a traumatic injury. It is important to treat the injury surgically as soon as possible. Do not delay treatment to research toxicity. Toxicity is a concern with some exotic coatings injected directly into the bloodstream. Consultation with a plastic surgeon or reconstructive hand surgeon may be advisable.*

Pressure relief procedure

To reduce the risk of serious bodily injury, including fluid injection and splashing in the eyes or on the skin, always follow this procedure whenever you stop spraying for more than 10 minutes, when shutting down, and before checking or repairing any part of the system.

1. Engage the trigger safety latch.
2. Turn the system off.
3. Disconnect the power supply.
4. Shut off the water supply.
5. Disengage the trigger safety latch and trigger the gun to relieve pressure, and then engage the trigger safety latch again.
6. Before long-term (overnight) storage, disconnect the water supply and disconnect the power supply.

Spray gun safety devices

Be sure all gun safety devices are operating properly before each use. Do not remove or modify any part of the gun; this can cause a malfunction and result in serious bodily injury.

Safety latch: Whenever you stop spraying for a moment, always set the gun safety latch in the engaged or “safe” position, making the gun inoperative. Failure to properly set the safety latch can result in accidental triggering of the gun.

Spray tip safety: Use extreme caution when cleaning or changing spray tips. If a spray tip clogs while spraying, engage the gun safety latch immediately. **Always relieve system pressure before removing the spray tip to clean it.**

2b. Fuel and emission hazards: engine driven products

Never fill the fuel tank while the unit is running or hot. The fuel is combustible and when spilled on a hot surface can ignite and cause a fire. **Always** fill tank slowly to avoid spilling.

Never operate the unit in a closed building. The exhaust contains carbon monoxide, a poisonous, odorless, invisible gas which can cause serious injury or death if inhaled.

Never alter the maximum throttle setting, which is factory set. Tampering with this adjustment can cause personal injury, damage the system, and will void the warranty.

2c. Grounding instructions: motor driven products

This product must be grounded. If it should malfunction or break down, grounding provides a path of least resistance for electric current to reduce the risk of electric shock. If the equipment is equipped with a cord having an equipment-grounding conductor and a grounding plug, the plug must be plugged into an appropriate outlet that is properly installed and grounded in accordance with all local codes and ordinances.



DANGER: Improper connection of the equipment-grounding conductor can result in the risk of electrocution. Check with a qualified electrician or service person if you are in doubt as to whether an outlet is properly grounded. **Do not modify any plug provided with the product – if it will not fit the outlet, have a proper outlet installed by a qualified electrician.**

2d. Extension cords: motor driven products

Use only 4-wire extension cords that have 4-prong grounding-type plugs and 4-pole cord connectors that accept the plug from the product. Use only extension cords that are intended for outdoor use. These extension cords are identified by a marking, "Acceptable for use with outdoor appliances; store indoors while not in use." Use only extension cords having an electrical rating not less than the rating of the product. Do not use damaged extension cords. Examine extension cord before using and replace if damaged. Do not abuse extension cord and do not yank or pull on any cord to disconnect. Keep cord away from heat and sharp edges. Always disconnect the extension cord from the receptacle before disconnecting the product from the extension cord.



WARNING: To reduce the risk of electrocution, keep all connections dry and off the ground. Do not touch plug with wet hands.

2e. Equipment misuse hazard

General safety

Any misuse of the pump or accessories, such as overpressurizing, modifying parts, using incompatible chemicals and fluids, or using worn or damaged parts, can cause them to rupture and result in fluid injection, splashing in the eyes or on the skin, or other serious bodily injury, fire, explosion or property damage.

Never alter or modify any part of this equipment; doing so could cause it to malfunction.

Check all equipment regularly and repair or replace worn or damaged parts immediately.

Always wear protective eyewear, hearing protection and appropriate clothing. If using a chemical, read and follow the chemical manufacturer's literature for recommendations on additional protective equipment, such as a respirator.

System pressure

This pump can develop high operating pressure. Be sure that all equipment and accessories are rated to withstand the maximum working pressure of this system. **Do not** exceed the maximum working pressure of any component or accessory used in the system.

Chemical compatibility

Be sure that all chemicals used are compatible with the wetted parts as given in the Technical Data. Always read the chemical manufacturer's literature before using any chemical.

2f. Hose safety

High pressure fluid in the hoses can be very dangerous. If the hose develops a leak, split or rupture due to any kind of wear, damage or misuse, the high pressure spray emitted from it can cause a fluid injection injury or other serious bodily injury or property damage.

ALL FLUID HOSES MUST HAVE STRAIN RELIEFS ON BOTH ENDS. The strain reliefs help protect the hose from kinks or bends at or close to the coupling, which can result in hose rupture.

Tighten all fluid connections securely before each use. High pressure fluid can dislodge a loose coupling or allow high pressure spray to be emitted from the coupling.

Never use a damaged hose. Before each use, check entire hose for cuts, leaks, abrasion, bulging cover, or damage or movement of the hose couplings. If any of these conditions exist, replace the hose immediately.

Do not try to recouple high pressure hose or mend it with tape or any other device. A repaired hose cannot contain the high pressure fluid.

HANDLE AND ROUTE HOSES CAREFULLY. Do not pull on hoses. Do not use chemicals which are not compatible with the inner tube and cover of the hose. **Do not** expose hose to temperatures above 200° F (93° C) or below -40° F (-40° C).

2g. Moving parts hazard

Moving parts can pinch or amputate fingers or other body parts. **Keep clear** of moving parts when starting or operating the system.

Never operate the system without all guards and interlocks installed and functioning. **Always** relieve system pressure before cleaning or servicing any part of the system to prevent discharging high pressure fluid from the gun.

2h. Terms



WARNING or **DANGER:** Alerts user to avoid or correct conditions that could cause bodily injury.



CAUTION: Alerts user to avoid or correct conditions that could cause damage to the equipment.

NOTE **NOTE:** Identifies helpful procedures and information.

IMPORTANT: United States Government safety standards have been adopted under the Occupational Safety and Health Act. These standards – particularly the General Standards, Part 1910, and the Construction Standards, Part 1926 – should be consulted.

3. PUMP IDENTIFICATION

Each pump is fitted with a rating plate. The specifications stamped on it are as follows:

- pump model and version
- maximum rpm
- maximum pressure and volume
- crankcase oil capacity and specification
- serial number

The pump model, pump version and serial number data must be specified when ordering spare parts. If the pump is modified, any change should be mentioned on the rating plate for future reference.

4. TECHNICAL FEATURES

The pump features:

- three horizontal plungers and five different bore sizes
- in-line horizontally-arranged valves
- double V-shaped pressure packings with special cooling system
- splash lubricated crank mechanism
- pulley, flexible joint or cardan shaft drive capabilities

PUMP MODELS

MODEL	RPM	Volume		Pressure		Power	
		L /min	GPM	Bar	PSI	KW	HP
HD 18	1000	30.5	7.9	500	7250	29.1	39.6
HD 20	1000	37.7	10	400	5800	29	39.4
HD 22	1000	45.6	12	320	4650	28.1	38.1
HD 25	1000	58.9	15.6	250	3600	28.3	38.5
HD 30	750	62.4	16.5	180	2600	21.6	29.4

FEATURES		
• Stroke	40 mm	1.57 in
• Max. Inlet Pressure	3 bar	45 psi
• Max. Inlet Water Temperature	60° C	150° F
• Oil Capacity	3.8 liters	1 gal.
• Weight	65 kg	145 lbs

*Performances refer to theoretical delivery with 100% volumetric efficiency.
Under normal operating conditions, pump volumetric efficiency is over 95%.
Please contact our technical staff in case of continuous, heavy-duty or special applications.*

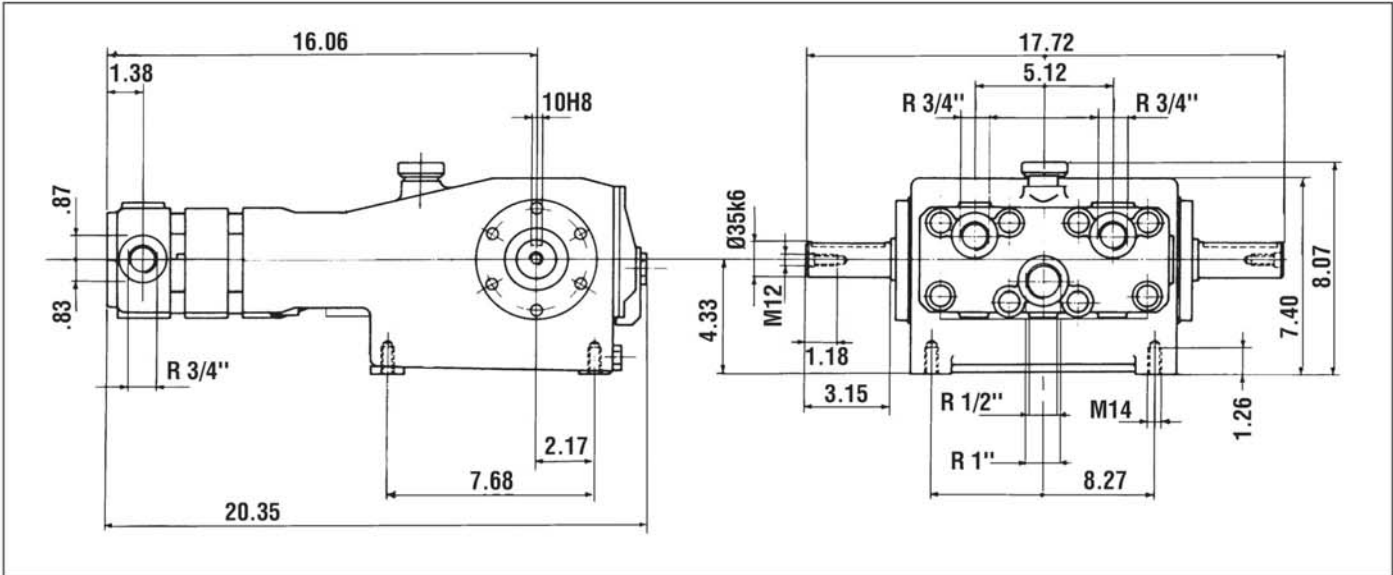

5. CONSTRUCTION FEATURES

A. CRANK MECHANISM Includes the cast iron crankcase containing the drive system components:

- gas-nitrided, hardened and tempered alloy steel crankshaft mounted on self-adjusting double roller shaft bearings.
- forged split connecting rods with special anti-friction bearings.
- surface-treated steel piston guides.
- splash lubricated by the pump crankcase oil.

B. PLUNGER AND PACKING SYSTEM Primarily composed of ceramic-coated stainless steel plungers and pressure packings with packing supports and cylinders. The pumping system is also greased to further increase the life of the pressure packings.

C. MANIFOLD Contains the inlet and discharge valves, made of stainless steel (HDN versions feature stainless steel fluid end and valves.)

6. GENERAL INFORMATION ON PUMP USE

The HD pump has been designed to pump, at room temperature, fresh, filtered water or other liquids of similar viscosity that are compatible with the wetted materials (for questionable liquids contact our Technical Department).

6a. Water temperature.

The maximum inlet water temperature is 150° F. Water temperature can be a significant factor in pump life. The higher the water temperature, the more likely it is to create cavitation, resulting in premature seal and valve failures.

For water above 100° F, follow these procedures:

- Feed the plunger pump with a centrifugal pump, supplying at least twice the plunger pump volume at 30 to 45 psi.
- Make the pump run more slowly, de-rating rpm by 30% at least (lowest allowable speed: 350 rpm)
- Make sure the crankshaft turns in the direction indicated by the arrows located near the drive shaft projection (see paragraph 8.b)

6b. Pump performance

Never exceed the maximum pump flow rate or pressure.

7. CONNECTIONS AND PLUGS

The HD pump has:

- 1"-NPT Inlet Port (1)**
- 3/4"-NPT Outlet Ports (3)** All three ports can be connected to the delivery line, depending on the accessories to be installed and delivery line characteristics. (The lateral port is normally used for the relief/unloader valve.)
- 1/4"-NPT Outlet Port (1)** Provided for the pressure gauge.
- 1/2"-NPT Outlet Port (1)** Provided for the safety valve.

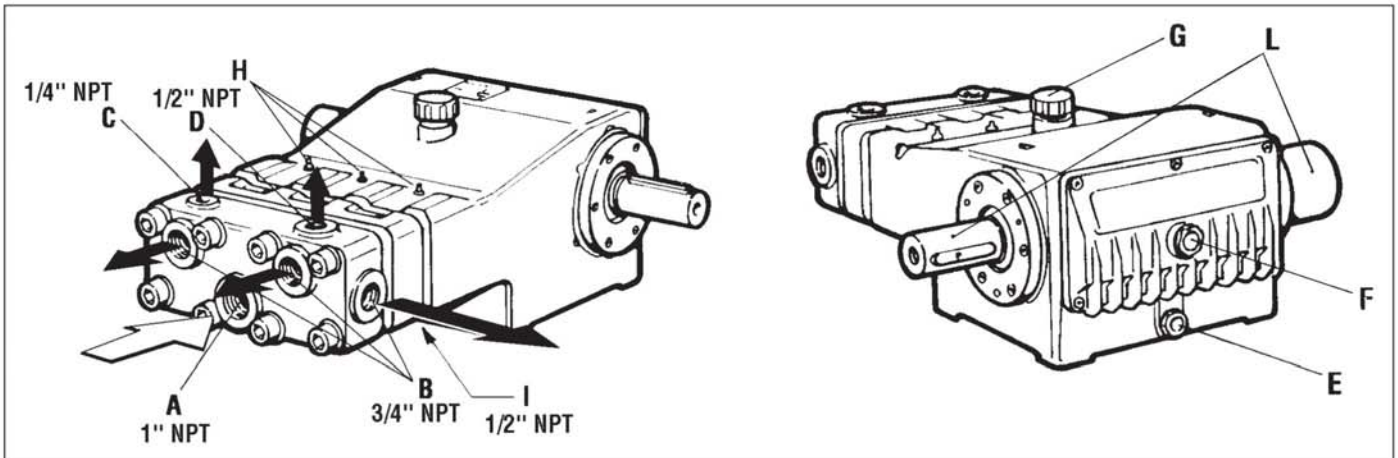

- Oil Drain Plug (1)** (position 11)* Used to empty the crankcase during oil changes. It includes a magnet to collect metal impurities inside the crankcase.
- Oil Level Sight Eye (1)** (position 12) For oil level monitoring.
- Oil Fill Plug (1)** (position 16) For oil change or topping off oil level.
- Greasers (3)**
- 1/2"-NPT Drain Hole** Used to drain water from the pressure packing chamber. Always leave this hole open.
- Shaft Projections (2)** 35 mm diameter, the one not being used should be protected by the cover (position 21).

*All positions are referenced as shown on the parts breakdown on page 14.

8. PUMP INSTALLATION

8a. Positioning

The pump must be mounted to a rigid and flat base using the four threaded feet in the crankcase.

Be sure maximum pump inclination during operation does not exceed 5° in order to guarantee the correct splash lubrication.

The base must not permit any misalignment or flexing of the pump/transmission coupling.

8b. Direction of rotation

The diagram at right shows the correct direction of rotation looking at the pump from the **fluid end side**:

- clockwise with shaft projecting on the left side
- counterclockwise with shaft projecting on the right side

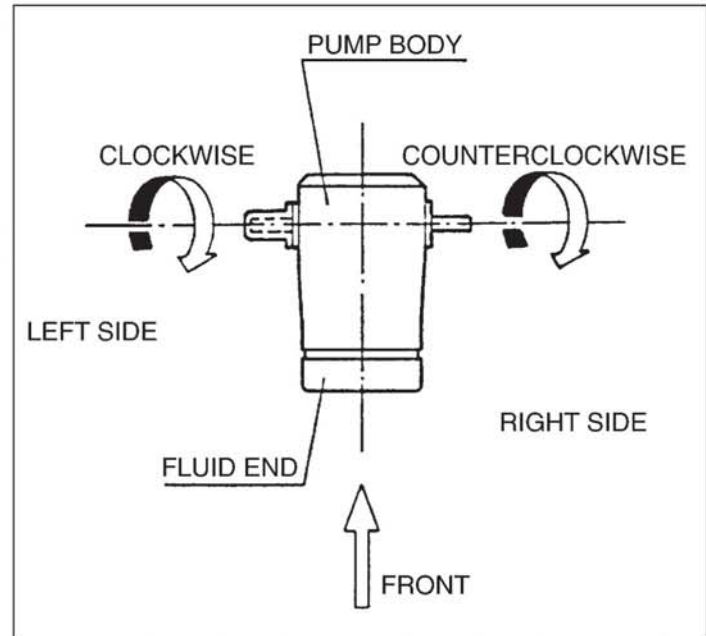

8c. Water line connections

In order to isolate any pump vibration, use flexible hoses for both the inlet and discharge lines. The flexible hose must be rigid enough not to collapse during the suction stroke, when a partial vacuum may occur.

8d. Pump feeding

HD pumps require an inlet pressure at the inlet port between 15 psi and 45 psi.

The feed pump (centrifugal type) must: (1) supply at least twice the plunger pump volume at the required pressure, (2) operate independently and (3) supply its full rated performance even if the plunger pump is run below its rated performances.

We recommend a pressure switch in the inlet line (after the filters) to prevent the HD pump from starting until the inlet pressure has reached 15 psi. This pressure switch will also stop the pump in case of filter clogging.

8e. Inlet line

THE INLET LINE **MUST** HAVE THE FOLLOWING CHARACTERISTICS:

- Minimum internal diameter of 30 mm (1.18 in.).
- No bends or changes in diameter within 12 inches of the suction port.
- Be airtight.
- Minimize all 90° elbows, diameter reductions, counter slopes and T-connections, and must not be connected with other pipelines within 10 diameters of inlet port.
- Be positioned so that it remains filled after the pump stops.

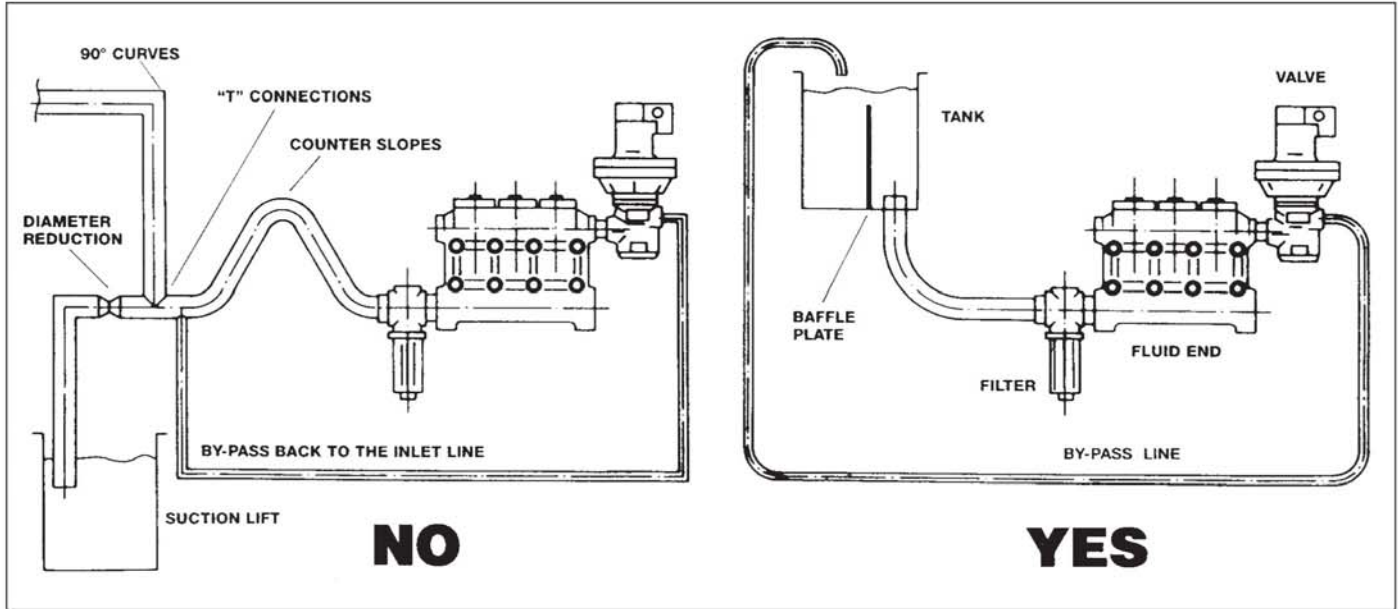

RECOMMENDATIONS:

- Do not connect the bypass line directly to the inlet line.
- Do not use high pressure flexible hose for the inlet line.
- Install the inlet pressure gauge after the filters and as close as possible to the pump inlet port.
- Be sure that the feed pump tank dimensions and the minimum water level do not create turbulence at the pump inlet port. Recommended minimum tank volume is five times discharge flow rate.
- Connect the by-pass directly to the feed tank and be sure that both the by-pass and feed tank flows do not create turbulence at the pump inlet port. Baffle plates should be inside the tank.
- Before connecting the suction line to the pump inlet port be sure the line is clean inside.
- Do not install a chemical injector on the inlet line.

8f. Filtration

HD pumps require 200 to 360 micron filtration.

The filters should be installed as close as possible to the pump, allow easy inspection and have the following characteristics:

- The capacity of each filter must be at least 3 times the rated pump volume.
- Filter port diameters should not be smaller than the pump inlet ports.

IMPORTANT NOTE: Clean the filters daily, more often in poor water conditions, to prevent premature pump wear and damage.

8g. Discharge line

To ensure the discharge line is correctly installed:

- The first length of hose must be flexible in order to isolate pump vibrations from the rest of the system.
- Install a suitable safety valve on the discharge line.
- Use only high pressure hoses and fittings that exceed the working pressure of the system.
- Use glycerine filled pressure gauges.

9. START-UP AND RUNNING PROCEDURES

9a. Start-up checks

Before starting the pump, be sure that the following conditions have been met:

- Inlet line must be connected, and tight: **the pump must never run dry.**
- All ON-OFF valves in between the pump and water supply must be open. Be sure water flows into the pump.
- Be sure all connections are tight.
- Set the discharge line into the dump mode, to prime the pump.
- Be sure joint alignment, belt tension or U-joint angle are within Manufacturer's specification.
- Check oil level.

NOTE If pump has not been operated for a long period of time, check the inlet and discharge lines for scaling.

9b. Start-up and operation

- Make sure the correct inlet pressure is provided.
- Do not start pump and motor (or engine) under load. Set the regulating valve to zero or set the discharge line into the dump mode.
- Check for proper direction of pump rotation.
- Be sure the rotating speed does not exceed the rated speed.
- Before putting the pump under pressure, let the pump run for some time until the oil flows freely.
- After stopping the pump, relieve the pressure from the system.

9c. Cooling system

During operation a small amount of water (a few drops a minute) is released from the pump fluid end. This leakage is designed to provide lubrication for the pressure packings. The leakage is drained out of the pump through a hole in the cover (position 13). **Always leave this hole open.**

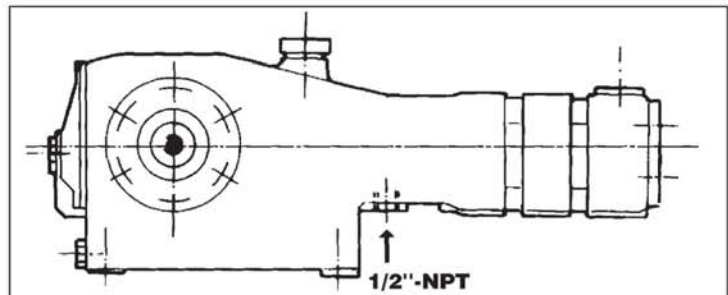

10. MAINTENANCE INSTRUCTIONS

10a. Crank mechanism maintenance

Check the oil level (position 12)* frequently. It should be checked on a weekly basis. Stop the pump and provide immediate service if water gets into the oil. Before filling the pump with new oil, wash the crankcase and crank mechanism with a solvent and allow to dry completely. Oil seals (position 36) should be replaced every three years.

Change oil after 50 working hours and every 500 working hours thereafter.

We recommend you use General Pump Industrial oil or its equivalent. (If working at normal room temperature – from 32° to 113° F – use General Pump Series 220 Oil (P/N 100217).)

Pump oil capacity is 1 gallon.

During oil changes, the pump oil should be at working temperature; be sure to clean the magnetic plug (position 11) and check the cover (position 13) for grease sediment.

**All positions are referenced as shown on the parts breakdown on page 14.*

10b. Fluid end maintenance

The fluid end **does not** require periodic maintenance.

Service operations are limited to valve inspection and/or replacement, when necessary:

- Step 1. Loosen two of the eight manifold screws (position 57) and replace them with the proper bolts with nuts, as shown at right.
- Step 2. Remove the manifold (position 55) and collector (position 49) as a single unit to avoid splitting valves. Separate on workbench.
- Step 3. Check the valve disk, seats and springs for wear, and replace if necessary.;

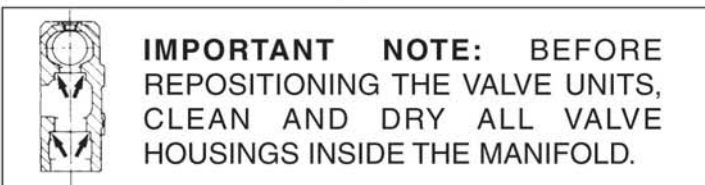

- Step 4. Replace all O-rings at every inspection.
- Step 5. Replace manifold screws (position 57) and tighten the screws to 144 ft.-lbs. in an alternating sequence, as shown in the diagram at right.

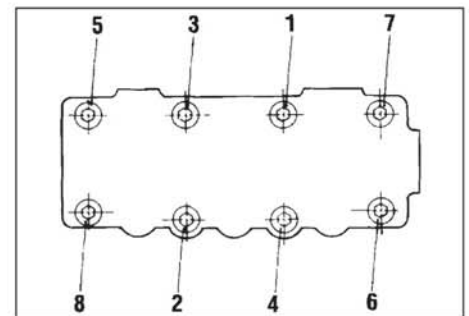
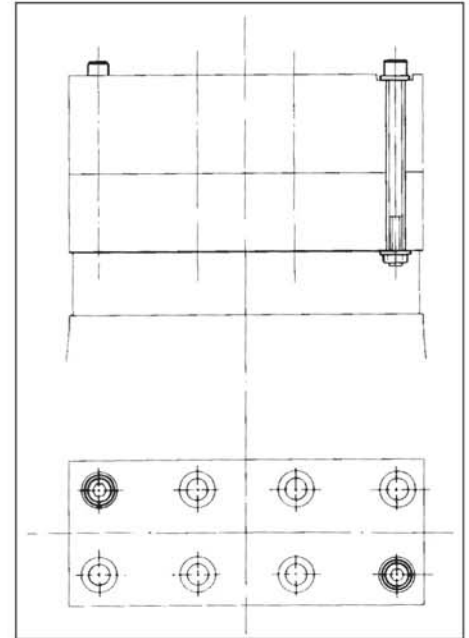

10c. Pressure packings and plungers maintenance

The only maintenance required for the pumping system is greasing the pressure packings through the greasers (position 34) located on the packing supports.

Greasing must be carried out at even intervals at least every 100 working hours by means of a hand pump. Stop greasing when the pump trigger becomes harder to operate: that means the grease chamber is full.

Use General Pump Packing Lubricant (p/n 100278).

Periodically check the amount of water drained out by the pump through the hole provided in the cover (position 13). It clearly shows the pressure packing state of wear; replace packings if water dripping becomes continuous.

**All positions are referenced as shown on the parts breakdown on page 14.*

Inspection/replacement of the pumping unit components:

- Step 1. Remove manifold (position 55) and collector (position 49) as described in section 10b.
- Step 2. Loosen the plunger fixing screws (position 32; the plunger position 29 for HD18-HDN18) without removing it.
- Step 3. Remove the complete pumping package (from position 37 up to position 43), without disassembling.
- Step 4. Remove the screw (position 32) and plunger (position 28; position 29 for HD18-HDN18).
- Step 5. Split the pumping unit on the workbench.
- Step 6. Check the components for wear and replace if necessary.

NOTE: The scraper (position 37) features a particular shape on its internal diameter which performs the correct scraping effect only if fitted in the correct position, as shown.

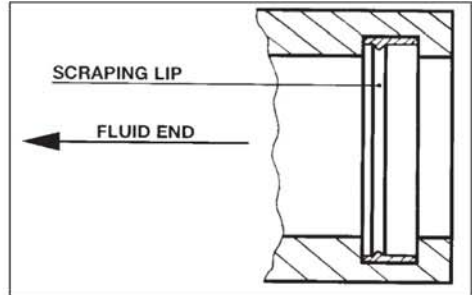

- Step 7. To fit the scraper into place, shape it with your fingers as shown. When replacing the pressure packings, apply a very small quantity of silicone grease on their lips to ease assembly.

Step 8. **When disassembling the pumping unit, the pressure packings and O-rings should always be replaced.**

- Step 9. Set up the complete pumping unit without tightening the cylinder (position 43).
- Step 10. Introduce the plunger into the pumping unit and then tighten the cylinder (position 43).
- Step 11. Install the pumping unit in the pump, paying attention to the correct position of the spacer (position 27) and wiper (position 26).



- Step 12. Tighten the plunger screw (position 32; the plunger position 29 for HD18-HDN18) with a torque wrench set for 40 ft.-lbs. The screw washer (position 30) should always be replaced.
- Step 13. Install the collector and manifold in one block and tighten the eight screws (position 57) to 144 ft.-lbs. in an alternating sequence as shown.
- Step 14. Grease the pumping unit through the greasers (position 34).

10d. Fastener torque values

Always use a torque wrench:

POSITION*	DESCRIPTION	Kgm	Nm	Ft-lbs
57	Fluid end screws	13	130	95.8
29	HD18 plunger	5.5	54	40
32	Plunger screws	5.5	54	40
19	Connecting rod screws	4	39	29
2	Side & rear cover screws	1	10	7.3

11. PUMP STOPPED FOR LONG PERIOD

Before starting the pump after a long period of inactivity: (1) check for correct oil level, (2) check the valves as indicated in section 10b and (3) use the starting procedures indicated in section 9.

When a long period of inactivity is scheduled, drain the entire suction and delivery line and run the pump for a few seconds to drain out all water.

12. FROST PRECAUTIONS

When there is risk of freezing:

- Drain all suction and delivery lines (filter included).
- Run the pump for a few seconds to drain the water collected inside the manifold. Flush the system with a 50-percent solution of anti-freeze until the anti-freeze works throughout the system.

WARNING: If a pump is frozen or appears frozen **DO NOT OPERATE THE PUMP** until the entire system has been thawed.

13. HDN Models

Installation, use and maintenance instructions for these models are the same as the standard ones. A rinse with pure water after use is recommended.

Torque values for HDN models

Tighten screws using a torque wrench.

POSITION*	DESCRIPTION	Kgm	Nm	Ft-lbs
57	Fluid end screws	13	130	95.8
29	HD18 plunger	4	39	29
32	Plunger screws	4	39	29
19	Connecting rod screws	4	39	29
2	Side & rear cover screws	1	10	7.3

*All positions are referenced as shown on the parts breakdown on page 14.

10e. Parts breakdown

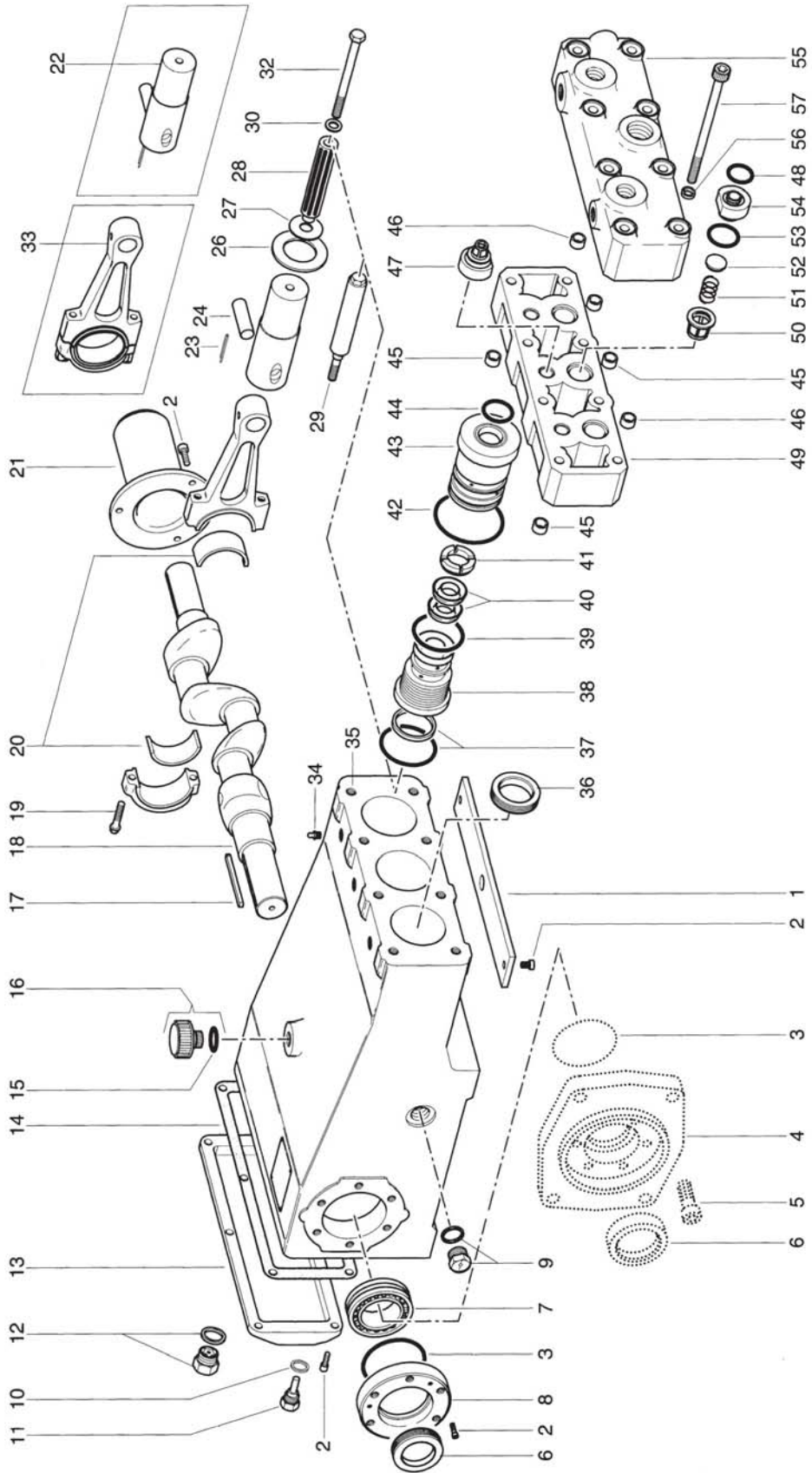

HD SERIES PARTS

Item	Part number	Description	Qty	Item	Part number	Description	Qty	Item	Part number	Description	Qty
1.	F040000130	Lower cover	1	27.	F010200010	Spacer HD 20-22-25-30	3	41.	F031200050	Head ring HD 18	3
2.	F871115153	SHCS M 6x16	17-23		F010200000	Spacer HD 18	3		F031200040	Head ring HD 20	3
3.	F881013100	OR Ø 80x2.5	2	28.	F024200080	Plunger HD 20	3		F031200030	Head ring HD 22	3
4.	F010100050	Motor Flange Hydraulic (Type A)	1		F024200070	Plunger HD 22	3		F031200010	Head ring HD 25	3
	F010100040	Motor Flange Hydraulic (Type B)	1		F024200060	Plunger HD 25	3		F031200020	Head ring HD 30	3
5.	F871125154	SHCS M 10x30	6	29.	F024200050	Plunger HD 30	3	42.	F881010124	OR Ø 50.47x2.62	3
6.	F881080014	Radial seal Ø 40x60x10	2		F124200180	Plunger HD 18	3	43.	F062300210	Cylinder HD 18	3
7.	F811110002	Bearing	2	30.	F872040101	Washer Ø10 HD 20-22-25-30 - Spec.	3		F062300040	Cylinder HD 20	3
8.	F063400100	Side cover	1-2	32.	F035200000	Plunger bolt HD 20-22-25-30	3		F062300030	Cylinder HD 22	3
9.	F801053002	Oil level sight Glass G 1/2"	1	33.	F250000050	Connecting rod assembly	3		F062300020	Cylinder HD 25	3
10.	F872043001	Aluminum washer Ø 3/8"	1	34.	F801077003	Grease fitting M 10x1	3		F062300010	Cylinder HD 30	3
11.	F801057001	Magnetic plug G 3/8"	1	35.	F060100070	Crankcase	1	44.	F881010211	OR Ø 37.69x3.53 - Spec.	3
12.	F801053003	Oil level sight glass G 3/4"	1		F060100080	Crankcase hydraulic	1	45.	F043500010	Bushing	12
13.	F063400120	Rear cover	1	36.	F881081002	Seal Ø 38x52x7 - Spec.	3	46.	F031200060	Manifold bushing	4
14.	F080600000	Gasket, rear cover	1	37.	F881061006	Scraper HD 18	3	47.	F208004400	Valve assembly	6
15.	F881011173	OR Ø18x3	1		F881061007	Scraper HD 20	3	48.	F881011151	OR Ø 22x3 - Spec.	6
16.	F801054002	Vented cap G 1/2"	1		F881061008	Scraper HD 22	3	49.	F064100070	Collector	1
17.	F071000030	Key	1		F881061009	Scraper HD 25	3	50.	F021200010	Valve guide	6
18.	F050000030	Crankshaft	1		F881061011	Scraper HD 30	3	51.	F090200010	Spring	6
19.	F871350002	Rod cap bolt	6	38.	F022300740	Packing support HD 18	3	52.	F082200010	Valve poppet	6
20.	F812000002	Connecting rod bearing	3		F022300080	Packing support HD 20	3	53.	F881011153	OR Ø 26x3 - Spec.	6
21.	F040400010	Shaft cover	1		F022300070	Packing support HD 22	3	54.	F081200011	Valve seat	6
22.	F250001010	Piston guide assembly HD 20-22-25-30	3		F022300060	Packing support HD 25	3	55.	F064100090	Manifold	1
	F250001050	Piston guide assembly HD 18	3		F022300050	Packing support HD 30	3	56.	F030000000	Manifold washer	8
23.	F872138010	Roll pin Ø 2.5x22	3	39.	F881010120	OR Ø 42.5x2.62	3	57.	F871135320	SHCS M 14x160 - Spec.	8
24.	F071000020	Wrist pin Ø 20	3	40.	F881020000	Packings HD 18	6				
26.	F041200000	Flinger washer	3		F881020001	Packings HD 20	6				
					F881020003	Packings HD 22	6				
					F881020005	Packings HD 25	6				
					F881020006	Packings HD 30	6				

REPAIR KITS

ITEM	HD18	HD20	HD22	HD25	HD30
37-39-40-42-44	KIT 1028				HD30
30-37-39-40-42-44		KIT 1029	KIT 1030	KIT 1031	KIT 1032
44-48-53			KIT 1033		
3-6-10-14-15-23-34-36-37-39	KIT 1034				
40-42-44-48-53					
3-6-10-14-15-23-30-34-36-37		KIT 1035	KIT 1036	KIT 1037	KIT 1038
39-40-42-44-48-53					

10e. Parts breakdown

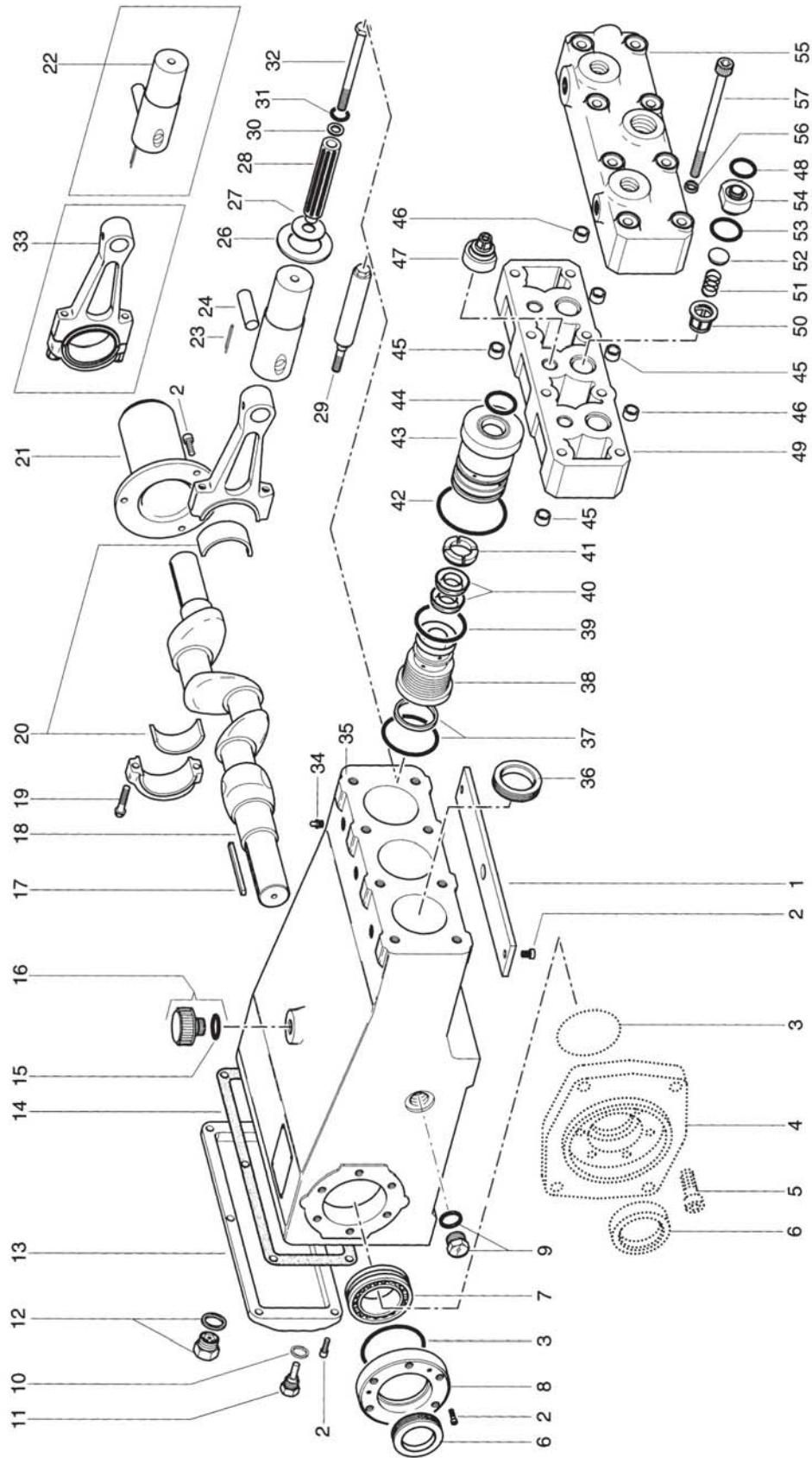

HDN SERIES PARTS

Item	Part number	Description	Qty	Item	Part number	Description	Qty	Item	Part number	Description	Qty
1.	F040000130	Lower cover	1	28.	F024200520	Plunger HDN 20	3	41.	F031200380	Head ring HDN 18	3
2.	F871115603	SHCS M 6x16 SS	17-23		F024200530	Plunger HDN 22	3		F031200390	Head ring HDN 20	3
3.	F881013100	OR Ø 80x2.5	2		F024200540	Plunger HDN 25	3		F031200400	Head ring HDN 22	3
4.	F010100050	Motor Flange Hydraulic (Type A)	1		F024200550	Plunger HDN 30	3		F031200410	Head ring HDN 25	3
	F010100040	Motor Flange Hydraulic (Type B)	1	29.	F124200190	Plunger HDN 18	3		F031200420	Head ring HDN 30	3
5.	F871125606	SHCS M 10x30 SS	6	30.	F010500030	Ring HDN 20-22-25-30	3	42.	F881010124	OR Ø 50.47x2.62	3
6.	F881080014	Radial seal Ø 40x60x10	2	31.	F881011100	OR Ø 8x2.5 HDN 20-22-25-30 -Spec.	3	43.	F062300220	Cylinder HDN 18	3
7.	F811110002	Bearing	2	32.	F035200070	Plunger bolt HDN 20-22-25-30	3		F062300160	Cylinder HDN 20	3
8.	F063400680	Side cover	1-2	33.	F250000050	Connecting rod assembly	3		F062300170	Cylinder HDN 22	3
9.	F801053002	Oil level sight glass G 1/2"	1	34.	F801077503	Grease fitting M 10x1 SS	3		F062300180	Cylinder HDN 25	3
10.	F030300000	Washer, nickel Ø 3/8"	1	35.	F060100070	Crankcase	1		F062300190	Cylinder HDN 30	3
11.	F801057011	Magnetic plug G 3/8"	1		F060100080	Crankcase hydraulic	1	44.	F881010211	OR Ø 37.69x3.53 - Spec.	3
12.	F801053003	Oil level sight glass G 3/4"	1	36.	F881081002	Seal Ø 38x52x7 - Spec.	3	45.	F043500010	Bushing	12
13.	F063400650	Rear cover	1	37.	F881061006	Scraper HDN 18	3	46.	F031200060	Manifold bushing	4
14.	F080600000	Gasket, rear cover	1		F881061007	Scraper HDN 20	3	47.	F208004400	Valve assembly	6
15.	F881011173	OR Ø18x3	1		F881061008	Scraper HDN 22	3	48.	F881011151	OR Ø 22x3 - Spec.	6
16.	F801054002	Vented cap G 1/2"	1		F881061009	Scraper HDN 25	3	49.	F064200050	Collector	1
17.	F071000030	Key	1		F881061011	Scraper HDN 30	3	50.	F021200010	Valve guide	6
18.	F050000030	Crankshaft	1	38.	F022300750	Packing support HDN 18	3	51.	F090200010	Spring	6
19.	F871350002	Rod cap bolt	6		F022300640	Packing support HDN 20	3	52.	F082200010	Valve poppet	6
20.	F812000002	Connecting rod bearing	3		F022300650	Packing support HDN 22	3	53.	F881011153	OR Ø 26x3 - Spec.	6
21.	F040400010	Shaft cover	1		F022300660	Packing support HDN 25	3	54.	F081200011	Valve seat	6
22.	F250001010	Piston guide assembly HDN 20-22-25-30	3	39.	F881010120	OR Ø 42.52x2.62	3	55.	F064200070	Manifold	1
	F250001050	Piston guide assembly HDN 18	3	40.	F881020000	Packings HDN 18	6	56.	F030000000	Manifold washer	8
23.	F872138010	Roll pin Ø 2.5x22	3		F881020001	Packings HDN 20	6	57.	F0350000050	Manifold bolt	8
24.	F071000020	Wrist pin Ø 20	3		F881020003	Packings HDN 22	6				
26.	F041200000	Flinger washer	3		F881020005	Packings HDN 25	6				
27.	F010200010	Spacer HDN 20-22-25-30	3		F881020006	Packings HDN 30	6				
	F010200000	Spacer HDN 18	3								

REPAIR KITS

ITEM	HD18	HD20	HD22	HD25	HD30
37-39-40-42-44	KIT 1028				
30-31-37-39-40-42-44		KIT 1043	KIT 1044	KIT1045	KIT1046
44-48-53		KIT 1033			
3-6-10-14-15-23-34-36-37-39	KIT 1047				
40-42-44-48-53					
3-6-10-14-15-23-30-31-34-36-37		KIT 1048	KIT 1049	KIT 1050	KIT 1051
39-40-42-44-48-53					

MAINTENANCE LOG

HOURS & DATE

Oil Change							
Grease							
Packing Replacement							
Plunger Replacement							
Valve Replacement							



GP Companies, Inc.

1174 Northland Drive
Mendota Heights, Minnesota 55120
(651) 686-2199 • Fax: (800)535-1745
sales@gpcompanies.com • www.generalpump.com