

# 2010

## Pumps & Accessories Catalog



**GENERAL PUMP**

# Reasons to use General Pump



## Reliability

General Pump products have been industry-tested world-wide for 33 years, and in the United States for the past 28 years. General Pump is affiliated with the world's largest manufacturers of high-pressure water plunger pumps and accessories. You can rely on General Pump's wide range of products that fill many niches in the market and cater to customers' specific needs. You can depend on the flexibility and efficiency of General Pump's manufacturing and distribution processes.

## Versatility

General Pump offers a variety of pump, accessory and nozzle models with flows up to 112 GPM and pressures to 21,750 PSI. General Pump has put more than one million pumps into various applications over the last 27 years. These pumps are complemented with a broad array of accessories and nozzles to meet specific customer requirements.



## Economic Quality

Maintenance and repair of GP pumps and accessories is simple and inexpensive. When you compare the life-cycle cost of GP to others in the market, you will find GP products are the choice for best value. Availability of replacement parts and kits is always a critical issue when choosing a supplier. General Pump is a US-based distributor/manufacturer with a full inventory of pumps, accessories, nozzles and repair parts ready for immediate delivery.



## Commitment to Support

General Pump has a well-trained staff including, Inside and Outside Sales, Applications Engineering and Design Engineering groups ready to provide customers with training, information and support. Comprehensive training schools are held frequently at our world-class training facility.

[www.generalspump.com](http://www.generalspump.com)



# Engineering & Manufacturing



Since 1982, General Pump has developed a leading position as a designer and manufacturer of innovative products for the power wash industry. Located at our manufacturing facility in Eagan, MN our dedicated engineering teams are ideally positioned to tap into the trends moving the US market. Working closely with our OEM partners, these teams use state-of-the-art design tools and suppliers to bring to market the innovative, yet cost-effective solutions to meet our customer's needs.

In recent years the emergence of General Pump's own Minnesota-based manufacturing capability has brought a new level of service to the US market. Our capacity has expanded and we offer a wide range of products built to order, made in the USA, for the American market.

Importantly, this local market support is now the strongest in our industry, thanks to the financial backing of the Interpump Group, the world's leader in high-pressure plunger pump technology and production. As a result, General Pump is uniquely positioned in the US market to engineer, manufacture and timely deliver the complete range of solutions required by the power wash industry.



## Dedicated Engineering

- Design teams dedicated to accessory and nozzle development
- Source of innovative products like the Pump Thermal Protector line (PTP), the dual port injector, the 6000 PSI Safety Valve, the Quick Disconnect Injector Line, and our new 6000-PSI flow switch
- State-of-the-art design support including 3D CAD modeling and ANSYS fluid and stress analysis software



## In-House Design

- Dedicated engineering resources for product customization and design support
- Dedicated prototype shop ensures timely turnaround of new products
- In-house machine design has provided General Pump's manufacturing department with innovative assembly work stations

[www.generalspump.com](http://www.generalspump.com)



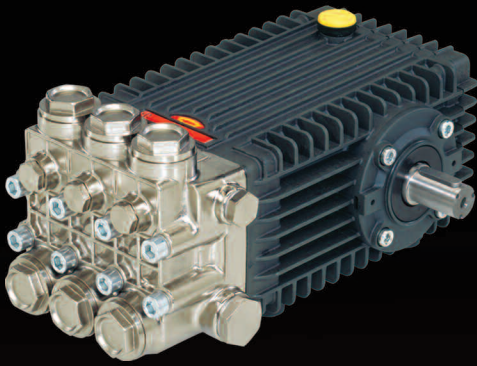

**HTF Series (66HT)** - Designed for use in prep units, conveyor and multiple gun applications. Excellent for carpet cleaning and for use in industrial plant systems where hot water is required.



**HTX Series (63HT)** - Specifically designed to handle the rigorous duty cycles, high temperatures and chemicals associated with self-service car wash applications. Also ideal for use in carpet cleaning and other high pressure cleaning applications. This pump offers a compact and economical design.



**HTS Series (47HT)** - Specifically designed to handle the rigorous duty cycles, high temperatures and chemicals associated with self-service car wash applications. Also ideal for use in carpet cleaning and other high pressure cleaning applications.



**HTW Series (69HT)** - Designed for touchless car wash systems, multiple gun systems and industrial plant systems where hot water is required.



**HTCK (3623S)** - Designed specifically for use in rollover car wash systems and other industrial plant systems where hot water is required.

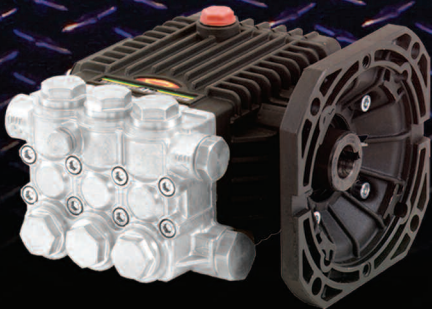

**HTC Series (60HT)** - Ideal for use in carpet cleaning and other high pressure cleaning applications. This pump offers a compact and economical design.

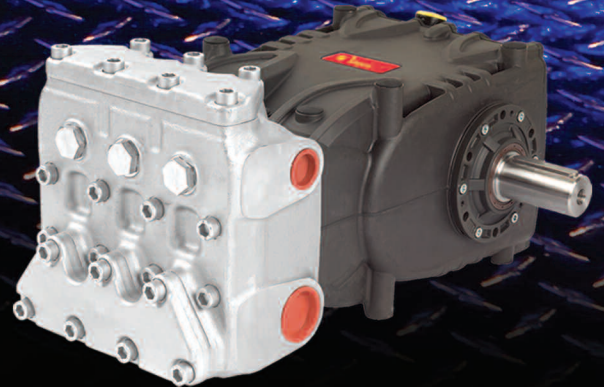

**HTCK (4050S)** - Featuring General Pump's patented HT Technology. Ideal for use in rollover car washes and other industrial plant systems where hot water is required.

# THE EMPEROR LINE OF PUMPS WITH HT TECHNOLOGY



# TABLE OF CONTENTS

## PRESSURE CLEANING PUMPS

PAGES 1-11

Series 49 Duplex Pumps, TT Series 51 Pumps .....	1
TT Series 51 Pumps .....	2
TP Series 51 Pumps, 60 Series Pumps .....	3
60 Series Pumps .....	4
TX Series 63 Pumps .....	5
TX Series 63 Pumps and EZ Series 44 Pumps.....	6
EZ Series Pumps and Series 50 Pumps.....	7
Series 47 Pumps .....	8
66 Series Pumps and Series 76 Pumps.....	9
Series 76, Series 48 and Series 77 Pumps.....	10
Series 77 Pumps and AT Series 76 Agricultural Pumps .....	11

## EMPEROR PUMPS

PAGES 13-14

Emperor HTC, HTS 47HT and HTX 63HT Series Pumps .....	13
Emperor HTF 66HT, HTW 69HT, HTCK3623S and HTCK4050S Series Pumps.....	14

## INDUSTRIAL PUMPS

PAGES 15-45

<b>General Industrial Pumps</b>	
KE Series.....	17
HF Series.....	18
KF Series.....	19
KFM Series .....	20
KS Series.....	21
MSS Series .....	22
MK 40/45/50 Series .....	23
MK 55/60/65 Series .....	24
MKS 40/45/50 Series .....	25
MKS 55/60/65 Series.....	26
LK Series.....	27
VF Series .....	28
VK Series.....	29
VS Series.....	30
SK Series.....	31
<b>Aggressive Environment Pumps</b>	
WM Series .....	32
TX Series 63 .....	33
T Series 47 .....	34
TSF Series 66.....	35
KEZ Series.....	36
KFZ Series.....	37
MSN/MSZ Series.....	38
LHN/LHZ Series .....	39
Gear Box.....	40
Hydraulic Drive .....	41
<b>Industrial Pump Fittings and Accessories</b>	
Fitting Kits, Pump Fittings and Seal Rings.....	42
Fittings, Industrial Unloaders and Regulating Valves .....	43
Jetting Valves, Safety Relief Valves, Industrial Valves, Pneumatic Valves and Foot Valves .....	44
Pulsation Dampeners, Industrial Spray Guns, Industrial Nozzles and Industrial Filters .....	45

## VEHICLE CLEANING PUMPS

PAGES 46-54

Emperor HTS 47HT, HTX 63HT, HTF 66HT and HTW 69HT Series Pumps.....	47
Emperor HTCK3623S and HTCK4050S Series Pumps .....	48
Series 47, 69, 76 and 77 Pumps .....	49

# TABLE OF CONTENTS

## VEHICLE CLEANING PUMPS

<p><b>Vehicle Cleaning Accessories</b>          Swivels, Squeegees, Nozzle Packs ..... 50          Regulators, Relief Valves, Unloaders, Check Valves, Accumulators          and Spray Guns ..... 51          Lances, Flexible Lances, Flow Switches..... 52          Chemical Injectors..... 53-54</p>	<p>PAGES 46-54 (CONTINUED)</p>
<p><b>Drive Components</b>          Gear Reducers and Multipliers, Flex Couplers, Flanges..... 56          Pulleys, Clutches and Oil..... 57  <b>Valves</b>          Trapped Pressure Unloaders ..... 58          Trapped Pressure and Adjustable Trapped Pressure Unloaders ... 59          Adjustable Trapped Pressure Unloaders..... 60          Modified Pressure and Control Set Unloaders ..... 61          Direct Mount Unloaders and Flow Sensitive Unloaders..... 62          Balanced Relief and Regulating Valves..... 63          Safety Relief Valves..... 64          Pump Thermal Protectors and Easy Start Valves ..... 65          Bleeder, Check, Steam and Needle Valves..... 66  <b>Injectors</b>          Adjustable Chemical Injectors..... 67          Adjustable Chemical Injectors ..... 68          Adjustable Chemical Injectors..... 69          Fixed Chemical Injectors..... 70          Fixed Chemical Injectors, Pulse Pumps and Chemical Valves..... 71  <b>Guns and Lances</b>          Front Entry and Rear Entry Spray Guns ..... 72-73          Rear Entry Spray Guns and Spray Guns with Lance..... 74          Stainless Steel Lances, Straight and Bent Insulated Lances..... 75          Double Lances, Lance Accessories and Quick Lances..... 76  <b>Pressure Cleaning Accessories</b>          Flat Surface Cleaner, Hose Reels and Water Brooms ..... 77          Telescoping Wands, Foamers, Brushes ..... 78  <b>Spray Tips and Nozzles</b>          Standard Spray Tips ..... 79          Chemical Spray Tips and Nozzle Packs..... 80          Adjustable Nozzles..... 81          Rotating Nozzles and Adjustable Rotating Nozzles ..... 82          Drain Cleaning Nozzles, Nozzle Holders and Steam Nozzles ..... 83          Tank Cleaning Nozzles..... 84  <b>Couplers and Fittings</b>          Quick Disconnect Couplers and Garden Hose Fittings..... 85          Garden Hose Fittings..... 86          Quick Disconnect Fittings..... 87  <b>Filters and Strainers</b>          Inline High Pressure Filters and Chemical Filters ..... 88          Inline Filters and Inlet Strainers..... 89  <b>Gauges and Switches</b>          Thermostats and Pressure Switches ..... 90          Flow Switches..... 91  <b>Miscellaneous Accessories</b>          Gauges and High-Pressure Swivels ..... 92          Pressure Washers, Accumulators/Pulsation Dampeners          Floats and Tanks ..... 93          Sandblasting Nozzles and Service Products..... 94  <b>Terms and Conditions of Sales, Return Policy</b> ..... 95  <b>Pump and Power Unit(s) Warranty</b> ..... 96-97  <b>Accessory Warranty</b> ..... 97  <b>Reference Information</b> ..... 98  <b>Nozzle Chart</b>..... 99</p>	<p>PAGES 55-94</p>

# PRESSURE CLEANING



## **Automotive**

- Municipal vehicle maintenance
- Bug and tar removal
- General exterior cleaning

## **Surface cleaning**

- Sidewalks
- Driveways

## **Household exterior cleaning**

- Mildew removal
- Storm cleanup
- Pool decks
- Gutter cleaning

## **Pre-painting surface preparation**

- Surface cleaning
- Paint removal
- Wet-sandblasting

## **Heavy equipment maintenance**

- Dirt and mud removal
- Grease and oil removal
- Parts washing

## **Contract cleaning**

- Building exterior cleaning
- Sidewalk cleaning
- Driveway cleaning
- Deck cleaning
- Restaurant kitchen cleaning
- Hood and duct cleaning
- Mobile vehicle wash
- Ice abatement
- Wet sandblasting
- General cleaning

# PRESSURE CLEANING PUMPS

T Series 49, Duplex Plunger Pump, Solid Shaft – Duplex pulsing action for improved impacted cleaning, ideal for drain cleaning and jetting applications. Forged brass manifold with an exclusive lifetime warranty.

**Max. Inlet Pressure: 125 PSI Max. Fluid Temperature: 165° F Inlet Port Thread: 1/2" - 14 BSP-F**

**Discharge Port Thread: 3/8" - 19 BSP-F Shaft Diameter: .625 in./16 mm I.D.**

**Pump Dimensions: 8.8" x 6.8" x 5.4" Max. Inlet Vacuum: 9 ft. water (7.9 in. Hg)**

**Crankcase Oil Capacity: 10.1 oz. Use GP Series 100 Oil, (see page 57) Product Group: U**

	GPM	PSI	RPM	BORE	STROKE	HP	SHP WGHT
T9721B	2.1 GPM	1000 PSI	1750 RPM	.787 in./20 mm	.307 in./7.8 mm	1.4 EBHP	11.0 lbs.
T721B	2.2 GPM	1200 PSI	1450 RPM	.787 in./20 mm	.374 in./9.5 mm	1.8 EBHP	11.0 lbs.
T9731B	2.85 GPM	1000 PSI	1750 RPM	.787 in./20 mm	.414 in./10.5 mm	2.0 EBHP	11.0 lbs.
T731B	3.0 GPM	1200 PSI	1450 RPM	.787 in./20 mm	.472 in./12.0 mm	2.5 EBHP	11.0 lbs.
T731B	3.5 GPM	1000 PSI	1750 RPM	.787 in./20 mm	.472 in./12.0 mm	2.4 EBHP	11.0 lbs.



**T721B**

T Series 49, Duplex Plunger Pump, Hollow Shaft, NEMA 56 C Flange for Direct Couple to Electric Motors – Duplex pump specifically designed for the demands of the water jetting industry. Forged brass manifold with an exclusive lifetime warranty.

**Max. Inlet Pressure: 125 PSI Max. Fluid Temperature: 165° F Inlet Port Thread: 1/2" - 14 BSP-F**

**Discharge Port Thread: 3/8" - 19 BSP-F Shaft Diameter: .625 in./16 mm I.D.**

**Pump Dimensions: 8.8" x 6.8" x 5.4" Max. Inlet Vacuum: 9 ft. water (7.9 in. Hg)**

**Crankcase Oil Capacity: 10.1 oz. Use GP Series 100 Oil, (see page 57) Product Group: U**

	GPM	PSI	RPM	BORE	STROKE	HP	SHP WGHT
T9711EBF	1.70 GPM	1500 PSI	1750 RPM	.787 in./20 mm	.260 in./6.6 mm	1.7 EBHP	16.0 lbs.
T9721EBF	2.11 GPM	1500 PSI	1750 RPM	.787 in./20 mm	.307 in./7.8 mm	2.2 EBHP	16.0 lbs.
T9731EBF	2.85 GPM	1500 PSI	1750 RPM	.787 in./20 mm	.413 in./10.5 mm	2.9 EBHP	16.0 lbs.

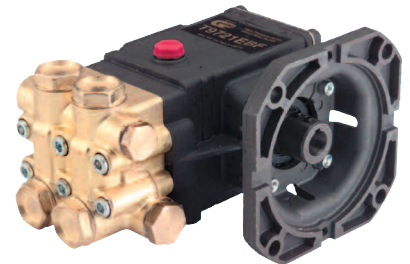

**T9721EBF**

TT Series 51, Triplex Plunger Pump, Hollow Shaft, Flanged for Direct Couple to Electric Motors (NEMA-56C) – Ideal for all general cleaning and misting applications. Forged brass manifold with exclusive lifetime warranty.

**Max. Inlet Pressure: 80 PSI Max. Fluid Temperature: 165° F Inlet Port Thread: 3/8" - 19 BSP-F**

**Discharge Port Thread: 1/4" - 19 BSP-F Shaft Diameter: .625 in./16 mm**

**Pump Dimensions: 7.0" x 7.2" x 5.5" Max. Inlet Vacuum: 3 ft. water (2.6 in. Hg)**

**Crankcase Oil Capacity: 11.2 oz. Use GP Series 100 Oil, (see page 57) Product Group: U**

	GPM	PSI	RPM	BORE	STROKE	HP	SHP WGHT
TT2021EBF	2.1 GPM	2000 PSI	3400 RPM	.591 in./15 mm	.197 in./5.0 mm	2.9 EBHP	11.5 lbs.
T9051EBF	2.11 GPM	1500 PSI	1750 RPM	.591 in./15 mm	.370 in./9.4 mm	2.2 EBHP	11.5 lbs.
TT9061EBF	2.11 GPM	1500 PSI	3400 RPM	.591 in./15 mm	.197 in./5.0 mm	2.2 EBHP	11.5 lbs.
TT2028EBF	2.8 GPM	2000 PSI	3400 RPM	.591 in./15 mm	.260 in./6.6 mm	3.8 EBHP	11.5 lbs.
TT9071EBF	2.8 GPM	1500 PSI	3400 RPM	.591 in./15 mm	.260 in./6.6 mm	2.9 EBHP	11.5 lbs.
TT9111EBF	3.0 GPM	1500 PSI	1750 RPM	.709 in./18 mm	.370 in./9.4 mm	3.1 EBHP	11.5 lbs.

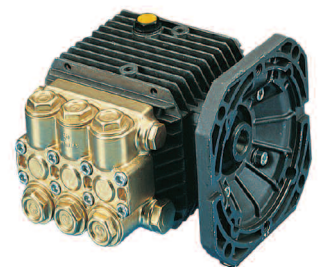

**TT1505EBF**

**Shaft: 3/4 in./19 mm**

TT2035EBF	3.5 GPM	2000 PSI	3400 RPM	.591 in./15 mm	.315 in./8.0 mm	4.8 EBHP	11.5 lbs.
-----------	---------	----------	----------	----------------	-----------------	----------	-----------



# PRESSURE CLEANING PUMPS

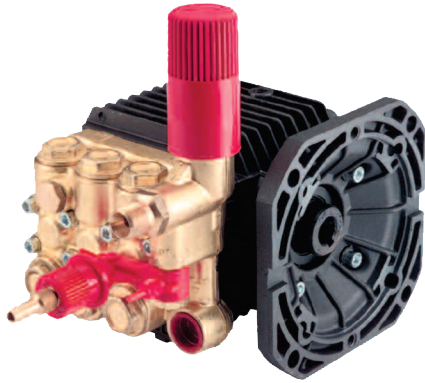

**TT9061EBFUI**

TT Series 51, Triplex Plunger Pump with Built-in Unloader, Hollow Shaft, Flanged for Direct Couple to Electric Motors (NEMA-56C). Ideal for all general cleaning and misting applications. Forged brass manifold with exclusive lifetime warranty.

**Max. Inlet Pressure: 80 PSI Max. Fluid Temperature: 165° F Inlet Port Thread: 1/2" - 14 BSP-M**

**Discharge Port Thread: 3/8" - 19 BSP-M Shaft Diameter: .625 in./16 mm**

**Pump Dimensions: 7.0" x 7.2" x 8.0" Max. Inlet Vacuum: 3 ft. water (2.6 in. Hg)**

**Crankcase Oil Capacity: 11.2 oz. Use GP Series 100 Oil, (see page 57) Product Group: U**

	GPM	PSI	RPM	BORE	STROKE	HP	SHP WGHT
TT9051EBFU	2.11 GPM	1500 PSI	1750 RPM	.591 in./15 mm	.370 in./9.4 mm	2.2 EBHP	12.0 lbs.
TT9061EBFU	2.11 GPM	1500 PSI	3400 RPM	.591 in./15 mm	.197 in./5.0 mm	2.2 EBHP	12.0 lbs.
TT9071EBFU	2.8 GPM	1500 PSI	3400 RPM	.591 in./15 mm	.260 in./6.6 mm	2.9 EBHP	12.0 lbs.

**Pump with Built-in Unloader and Downstream Injector**

TT9061EBFUI	2.11 GPM	1500 PSI	3400 RPM	.591 in./15 mm	.197 in./5.0 mm	2.2 EBHP	12.0 lbs.
T9051EBFUI	2.11 GPM	1500 PSI	1750 RPM	.591 in./15 mm	.370 in./9.4 mm	2.2 EBHP	12.0 lbs.
TT9071EBFUI	2.8 GPM	1500 PSI	3400 RPM	.591 in./15 mm	.260 in./6.6 mm	2.9 EBHP	12.0 lbs.
TT2035EBFUI	3.5 GPM	2000 PSI	3400 RPM	.591 in./15 mm	.315 in./8.0 mm	4.8 EBHP	12.0 lbs.

TT Series 51, Triplex Plunger Pump, Hollow Shaft, SAE J609A Flanged for Direct Couple to Gasoline Engines – Ideal for all general cleaning applications. Forged brass manifold with an exclusive lifetime warranty.

**Max. Inlet Pressure: 80 PSI Max. Fluid Temperature: 165° F Inlet Port Thread: 3/8" - 19 BSP-F**

**Discharge Port Thread: 1/4" - 19 BSP-F Shaft Diameter: .750 in./19 mm**

**Pump Dimensions: 7.2" x 7.2" x 5.5" Max. Inlet Vacuum: 3 ft. water (2.6 in. Hg)**

**Crankcase Oil Capacity: 11.2 oz. Use GP Series 100 Oil, (see page 57) Product Group: U**

	GPM	PSI	RPM	BORE	STROKE	HP	SHP WGHT
TT9061GBF	2.11 GPM	1500 PSI	3400 RPM	.591 in./15 mm	.197 in./5.0 mm	3.3 GHP	11.4 lbs.
TT2028GBF	2.8 GPM	2000 PSI	3400 RPM	.591 in./15 mm	.260 in./6.6 mm	5.8 GHP	11.4 lbs.
TT9071GBF	2.8 GPM	1500 PSI	3400 RPM	.591 in./15 mm	.260 in./6.6 mm	4.3 GHP	11.4 lbs.
TT2035GBF	3.5 GPM	2000 PSI	3400 RPM	.591 in./15 mm	.315 in./8.0 mm	7.2 GHP	11.4 lbs.
TT1540GBF	4.0 GPM	1500 PSI	3400 RPM	.591 in./15 mm	.370 in./9.4 mm	6.2 GHP	11.4 lbs.

TT Series 51, Triplex Plunger Pump with Solid Shaft – Standard with 24 mm solid shaft for pulley mount or direct drive with flex coupler and bell housing. Ideal for all general cleaning applications. Forged brass manifold with an exclusive lifetime warranty.

**Max. Inlet Pressure: 80 PSI Max. Fluid Temperature: 165° F Inlet Port Thread: 3/8" - 19 BSP-F**

**Discharge Port Thread: 1/4" - 19 BSP-F Shaft Diameter: .945 in./24 mm**

**Pump Dimensions: 7.0" x 6.9" x 5.1" Max. Inlet Vacuum: 3 ft. water (2.6 in. Hg)**

**Crankcase Oil Capacity: 11.2 oz. Use GP Series 100 Oil, (see page 57) Product Group: U**

	GPM	PSI	RPM	BORE	STROKE	HP	SHP WGHT
TT901	2.11 GPM	1500 PSI	2800 RPM	.591 in./15 mm	.236 in./6.0 mm	2.2 EBHP	11.2 lbs.
TT951	2.5 GPM	1500 PSI	2800 RPM	.591 in./15 mm	.283 in./7.2 mm	2.6 EBHP	11.2 lbs.
TT931	2.9 GPM	1500 PSI	2800 RPM	.591 in./15 mm	.315 in./8.0 mm	3.0 EBHP	11.2 lbs.
TT9111	3.0 GPM	1500 PSI	1750 RPM	.780 in./18 mm	.370 in./9.4 mm	3.1 EBHP	11.2 lbs.
TT941	3.43 GPM	1500 PSI	2800 RPM	.591 in./15 mm	.370 in./9.4 mm	3.5 EBHP	11.2 lbs.

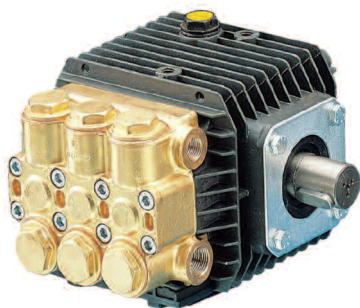

**TT901**

# PRESSURE CLEANING PUMPS

TP Series 51, Triplex Plunger Pump, Hollow Shaft, Flanged for Direct Couple to Gasoline Engines – New, oversized connecting rods for ultimate crankcase performance. Forged brass manifold with an exclusive lifetime warranty.

**Max. Inlet Pressure: 80 PSI Max. Fluid Temperature: 165° F Inlet Port Thread: 3/8" - 19 BSP-F**

**Discharge Port Thread: 1/4" - 19 BSP-F Shaft Diameter: .750 in./19 mm**

**Pump Dimensions: 7.0" x 7.2" x 5.5" Max. Inlet Vacuum: 3 ft. water (2.6 in. Hg)**

**Crankcase Oil Capacity: 11.0 oz. Use GP Series 100 Oil, (see page 57) Product Group: U**

	GPM	PSI	RPM	BORE	STROKE	HP	SHP WGHT
TP2520J34	1.9 GPM	2500 PSI	3400 RPM	.591 in./15 mm	.197 in./5.0 mm	4.9 GHP	11.4 lbs.
TP2526J34	2.6 GPM	2500 PSI	3400 RPM	.591 in./15 mm	.260 in./6.6 mm	6.7 GHP	11.4 lbs.
TP2530J34	2.88 GPM	2500 PSI	3400 RPM	.591 in./15 mm	.283 in./7.2 mm	7.4 GHP	11.4 lbs.
TP2533J34	3.3 GPM	2500 PSI	3400 RPM	.591 in./15 mm	.315 in./8.0 mm	8.5 GHP	11.4 lbs.



**TP2520J34**

TP Series 51, Triplex Plunger Pump with Built-in Unloader and Downstream Injector, Hollow Shaft, Flanged for Direct Couple to Gasoline Engines.

**Inlet Port Thread: 1/2" - 14 BSP-F Discharge Port Thread: 3/8" - 19 BSP-M Use GP Series 100 Oil, (see page 57)**

	GPM	PSI	RPM	BORE	STROKE	HP	SHP WGHT
TP2520J34UIL	1.9 GPM	2500 PSI	3400 RPM	.591 in./15 mm	.197 in./5.0 mm	4.9 GHP	11.4 lbs.
TP2526J34UIL	2.6 GPM	2700 PSI	3400 RPM	.591 in./15 mm	.256 in./6.5 mm	7.2 GHP	11.4 lbs.
TP2530J34UIL	2.88 GPM	2700 PSI	3400 RPM	.591 in./15 mm	.283 in./7.2 mm	8.0 GHP	11.4 lbs.
TP2533J34UIL	3.3 GPM	2500 PSI	3400 RPM	.591 in./15 mm	.315 in./8.0 mm	8.5 GHP	11.4 lbs.



**TP2530J34UIL**

TC Series 60, Triplex Plunger Pump, Compact Design, Solid Shaft – New long life low-pressure seal, oversized bearings and sight glass. Forged brass manifold with an exclusive lifetime warranty.

**Max. Inlet Pressure: 125 PSI Max. Fluid Temperature: 165° F Inlet Port Thread: 1/2" - 14 BSP-F**

**Discharge Port Thread: 3/8" - 19 BSP-F Shaft Diameter: .945 in./24 mm Gauge Port: 1/8"**

**Max. Inlet Vacuum: 3 ft. water (2.6 in. Hg) Pump Dimensions: 7.6" x 8.0" x 4.9"**

**Crankcase Oil Capacity: 11.8 oz. Use GP Series 100 Oil, (see page 57) Product Group: U**

	GPM	PSI	RPM	BORE	STROKE	SHP HP	WGHT
TC1509S17	1.75 GPM	2500 PSI	1450 RPM	.591 in./15 mm	.370 in./9.4 mm	3.0 EBHP	15.2 lbs.
TC1509S17	2.10 GPM	2500 PSI	1750 RPM	.591 in./15 mm	.370 in./9.4 mm	3.6 EBHP	15.2 lbs.
TC1511S17	2.10 GPM	2500 PSI	1450 RPM	.591 in./15 mm	.453 in./11.5 mm	3.6 EBHP	15.2 lbs.
TC1809S17	2.50 GPM	2200 PSI	1450 RPM	.709 in./18 mm	.370 in./9.4 mm	3.77 EBHP	15.2 lbs.
TC1511S17	2.60 GPM	2500 PSI	1750 RPM	.591 in./15 mm	.453 in./11.5 mm	4.45 EBHP	15.2 lbs.
TC1809S17	3.10 GPM	2200 PSI	1750 RPM	.709 in./18 mm	.370 in./9.4 mm	4.67 EBHP	15.2 lbs.
TC1811S17	3.25 GPM	2200 PSI	1450 RPM	.709 in./18 mm	.453 in./11.5 mm	4.9 EBHP	15.2 lbs.
TC1811S17	3.90 GPM	2200 PSI	1750 RPM	.709 in./18 mm	.453 in./11.5 mm	5.88 EBHP	15.2 lbs.

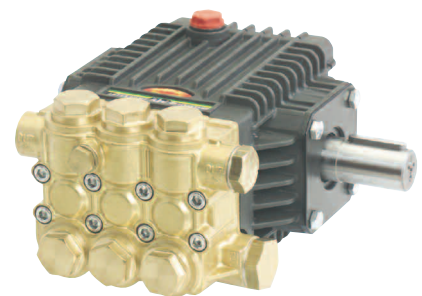

**TC1509S17**

**Max. Inlet Required: Flooded**

TC1507S34	3.0 GPM	2700 PSI	3400 RPM	.591 in./15 mm	.283 in./7.2 mm	5.55 EBHP	15.2 lbs.
TC1508S34	3.3 GPM	2500 PSI	3400 RPM	.591 in./15 mm	.315 in./8.0 mm	5.65 EBHP	15.2 lbs.

# PRESSURE CLEANING PUMPS

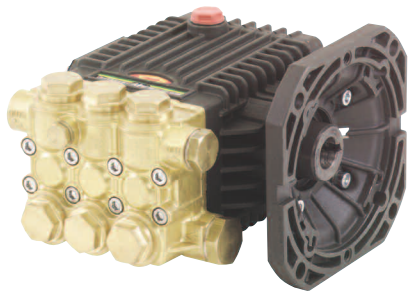

**TC1508E175**

TC Series 60, Triplex Plunger Pump, Compact Design, 5/8" Hollow Shaft, Flanged for Direct Couple to Electric Motors (NEMA 56C) – New long life low-pressure seal, oversized bearings and sight glass. Forged brass manifold with an exclusive lifetime warranty.

**Max. Inlet Pressure: 125 PSI Max. Fluid Temperature: 165° F Inlet Port Thread: 1/2" - 14 BSP-F Discharge Port Thread: 3/8" - 19 BSP-F Shaft Diameter: .625 in./16 mm Gauge Port: 1/8" Max. Inlet Vacuum: 3 ft. water (2.6 in. Hg) Pump Dimensions: 7.8" x 7.3" x 5.5" Crankcase Oil Capacity: 11.8 oz. Use GP Series 100 Oil, (see page 57) Product Group: U**

	GPM	PSI	RPM	BORE	STROKE	HP	SHP WGHT
TC1502E175	0.25 GPM	2500 PSI	1750 RPM	.591 in./15 mm	.079 in./2.0 mm	0.5 EBHP	15.1 lbs.
TC1802E175	0.5 GPM	2200 PSI	1750 RPM	.709 in./18 mm	.079 in./2.0 mm	0.8 EBHP	15.1 lbs.
TC1508E175	1.75 GPM	2500 PSI	1750 RPM	.591 in./15 mm	.315 in./8.0 mm	3.0 EBHP	15.1 lbs.
TC1509E175	2.10 GPM	2500 PSI	1750 RPM	.591 in./15 mm	.370 in./9.4 mm	3.6 EBHP	15.1 lbs.
TC1809E175	3.10 GPM	2200 PSI	1750 RPM	.709 in./18 mm	.370 in./9.4 mm	4.7 EBHP	15.1 lbs.



**TC1809E17N**

**Max. Inlet Vacuum: Flooded**

TC1504E345	1.75 GPM	2700 PSI	3400 RPM	.591 in./15 mm	.158 in./4.0 mm	3.2 EBHP	15.1 lbs.
TC1505E345	2.1 GPM	2700 PSI	3400 RPM	.591 in./15 mm	.197 in./5.0 mm	3.88 EBHP	15.1 lbs.
TC1506E345	2.6 GPM	2700 PSI	3400 RPM	.591 in./15 mm	.256 in./6.5 mm	4.81 EBHP	15.1 lbs.
TC1507E345	3.0 GPM	2700 PSI	3400 RPM	.591 in./15 mm	.283 in./7.2 mm	5.55 EBHP	15.1 lbs.

**No Flange for Direct Couple to Motor**

TC1509E17N	2.1 GPM	2500 PSI	1750 RPM	.591 in./15 mm	.370 in./9.4 mm	3.6 EBHP	15.1 lbs.
TC1809E17N	3.1 GPM	2200 PSI	1750 RPM	.708 in./18 mm	.370 in./9.4 mm	4.7 EBHP	15.1 lbs.

TC Series 60, Triplex Plunger Pump, Compact Design, 3/4" Hollow Shaft 56C Flange for Direct Coupling to Modified 56C Electric Motors.

	GPM	PSI	RPM	BORE	STROKE	HP	SHP WGHT
TC1506E346	2.6 GPM	2700 PSI	3400 RPM	.591 in./15 mm	.256 in./6.5 mm	4.81 EBHP	15.1 lbs.
TC1507E346	3.0 GPM	2700 PSI	3400 RPM	.591 in./15 mm	.283 in./7.2 mm	5.55 EBHP	15.1 lbs.
TC1508E346	3.3 GPM	2500 PSI	3400 RPM	.591 in./15 mm	.315 in./8.0 mm	5.65 EBHP	15.1 lbs.



**TC1506G**

TC Series 60, Triplex Plunger Pump, Compact Design, 3/4" Hollow Shaft, Flanged for Direct Couple to Gasoline Engines (SAE J609A) – New long life low-pressure seal, oversized bearings and sight glass. Forged brass manifold with an exclusive lifetime warranty.

**Max. Inlet Pressure: 125 PSI Max. Fluid Temperature: 165° F Inlet Port Thread: 1/2" - 14 BSP-F Discharge Port Thread: 3/8" - 19 BSP-F Shaft Diameter: .750 in./19 mm Gauge Port: 1/8" Max. Inlet Required: Flooded Pump Dimensions: 7.6" x 7.6" x 5.1" Crankcase Oil Capacity: 11.8 oz. Use GP Series 100 Oil, (see page 57) Product Group: U**

	GPM	PSI	RPM	BORE	STROKE	HP	SHP WGHT
TC1506G	2.6 GPM	2700 PSI	3400 RPM	.591 in./15 mm	.256 in./6.5 mm	7.21 GHP	14.6 lbs.
TC1507G	3.0 GPM	2700 PSI	3400 RPM	.591 in./15 mm	.283 in./7.2 mm	8.32 GHP	14.6 lbs.
TC1508G	3.3 GPM	2500 PSI	3400 RPM	.591 in./15 mm	.315 in./8.0 mm	8.48 GHP	14.6 lbs.
TC1509G	4.0 GPM	2500 PSI	3400 RPM	.591 in./15 mm	.370 in./9.4 mm	10.27 GHP	14.6 lbs.



**TC1506GUI**

TC Series 60, Triplex Plunger Pump, Compact Design, 3/4" Hollow Shaft, Flanged for Direct Couple to Gasoline Engines (SAE J609A) – Exclusive premium built-in trapped pressure unloader on the left side of manifold, new long life low-pressure seal, oversized bearings and sight glass. Forged brass manifold with an exclusive lifetime warranty.

**Max. Inlet Pressure: 125 PSI Max. Fluid Temperature: 165° F Inlet Port Thread: 1/2" - 14 BSP-F Discharge Port Thread: 3/8" - 19 BSP-F Shaft Diameter: .750 in./19 mm Gauge Port: 1/8" Max. Inlet Required: Flooded Pump Dimensions: 10.4" x 8.0" x 7.7" Crankcase Oil Capacity: 11.8 oz. Use GP Series 100 Oil, (see page 57) Product Group: U**

	GPM	PSI	RPM	BORE	STROKE	HP	SHP WGHT
TC1506GUI	2.6 GPM	2700 PSI	3400 RPM	.591 in./15 mm	.256 in./6.5 mm	7.21 GHP	16.0 lbs.
TC1507GUI	3.0 GPM	2700 PSI	3400 RPM	.591 in./15 mm	.283 in./7.2 mm	8.32 GHP	16.0 lbs.
TC1508GUI	3.3 GPM	2500 PSI	3400 RPM	.591 in./15 mm	.315 in./8.0 mm	8.48 GHP	16.0 lbs.
TC1509GUI	4.0 GPM	2500 PSI	3400 RPM	.591 in./15 mm	.370 in./9.4 mm	10.27 GHP	16.0 lbs.

# PRESSURE CLEANING PUMPS

TX Series 63, Triplex Plunger Pump, Solid Shaft – Large, lightweight connecting rods, new long life low and high pressure seals, oversized roller bearings and dual sight glasses. Forged brass manifold with an exclusive lifetime warranty.

**Max. Inlet Pressure: 125 PSI Max. Fluid Temperature: 165° F Inlet Port Thread: 1/2" - 14 BSP-F**

**Discharge Port Thread: 3/8" - 19 BSP-F Shaft Diameter: .945 in./24 mm**

**Pump Dimensions: 8.4" x 8.3" x 4.8" Max. Inlet Vacuum: 3 ft. water (2.6 in. Hg)**

**Crankcase Oil Capacity: 14 oz. Use GP Series 100 Oil, (see page 57) Product Group: W**

	GPM	PSI	RPM	BORE	STROKE	HP	SHP WGHT
TX1512S17	2.1 GPM	3000 PSI	1450 RPM	.591 in./15 mm	.472 in./12 mm	4.3 EBHP	19.0 lbs.
TX1512S17	2.6 GPM	3000 PSI	1750 RPM	.591 in./15 mm	.472 in./12 mm	5.3 EBHP	19.0 lbs.
TX1810S17	2.7 GPM	2000 PSI	1450 RPM	.709 in./18 mm	.394 in./10 mm	3.7 EBHP	19.0 lbs.
TX1810S17	3.2 GPM	2000 PSI	1750 RPM	.709 in./18 mm	.394 in./10 mm	4.2 EBHP	19.0 lbs.
TX1812S17	3.2 GPM	2000 PSI	1450 RPM	.709 in./18 mm	.472 in./12 mm	4.4 EBHP	19.0 lbs.
TX1812S17	3.8 GPM	2000 PSI	1750 RPM	.709 in./18 mm	.472 in./12 mm	5.2 EBHP	19.0 lbs.

**Max. Inlet Vacuum: Flooded**

TX1506S34	2.6 GPM	3000 PSI	3400 RPM	.591 in./15 mm	.256 in./6.5 mm	5.3 EBHP	19.0 lbs.
TX1508S34	3.0 GPM	3000 PSI	3400 RPM	.591 in./15 mm	.315 in./8.0 mm	6.2 EBHP	19.0 lbs.
TX1510S34	4.0 GPM	3000 PSI	3400 RPM	.591 in./15 mm	.394 in./10 mm	8.2 EBHP	19.0 lbs.

TX Series 63, Triplex Plunger Pump with 1.125" Hollow Shaft, Flanged for Direct Couple to NEMA 184TC Electric Motor – Large, lightweight connecting rods, new long life low-and high-pressure seals, oversized roller bearings and dual sight glasses. Forged brass manifold with an exclusive lifetime warranty.

**Max. Inlet Pressure: 125 PSI Max. Fluid Temperature: 165° F Inlet Port Thread: 1/2" - 14 BSP-F**

**Discharge Port Thread: 3/8" - 19 BSP-F Shaft Diameter: 1.125 in./28.5 mm**

**Pump Dimensions: 8.6" x 7.9" x 5.7" Max. Inlet Vacuum: 3 ft. water (2.6 in. Hg)**

**Crankcase Oil Capacity: 14 oz. Use GP Series 100 Oil, (see page 57) Product Group: W**

	GPM	PSI	RPM	BORE	STROKE	HP	SHP WGHT
TX1510E349	2.1 GPM	3000 PSI	1750 RPM	.591 in./15 mm	.394 in./10 mm	4.3 EBHP	18.0 lbs.
TX1512E179	2.6 GPM	3000 PSI	1750 RPM	.591 in./15 mm	.472 in./12 mm	5.3 EBHP	18.0 lbs.
TX1810E179	3.2 GPM	2000 PSI	1750 RPM	.708 in./18 mm	.394 in./10 mm	4.4 EBHP	18.0 lbs.
TX1812E179	3.8 GPM	2000 PSI	1750 RPM	.708 in./18 mm	.472 in./12 mm	5.2 EBHP	18.0 lbs.

**Max. Inlet Required: Flooded**

TX1510E349	4.0 GPM	3000 PSI	3400 RPM	.591 in./15 mm	.394 in./10 mm	8.2 EBHP	18.0 lbs.
------------	---------	----------	----------	----------------	----------------	----------	-----------

TX Series 63, Triplex Plunger Pump, 3/4" Hollow Shaft, Flanged for Direct Couple to Gasoline Engines (SAE J609B) – Large, lightweight connecting rods, new long life low-and high-pressure seals, oversized roller bearings and dual sight glasses. Forged brass manifold with an exclusive lifetime warranty.

**Max. Inlet Pressure: 125 PSI Max. Fluid Temperature: 165° F Inlet Port Thread: 1/2" - 14 BSP-F**

**Discharge Port Thread: 3/8" - 19 BSP-F Shaft Diameter: .750 in./19 mm**

**Pump Dimensions: 8.4" x 8.3" x 4.8" Max. Inlet Required: Flooded Crankcase Oil Capacity: 14 oz.**

**Use GP Series 100 Oil, (see page 57) Product Group: W**

	GPM	PSI	RPM	BORE	STROKE	HP	SHP WGHT
TX1505G6	2.0 GPM	3000 PSI	3400 RPM	.591 in./15 mm	.197 in./5.0 mm	6.2 GHP	18.0 lbs.
TX1506G6	2.6 GPM	3000 PSI	3400 RPM	.591 in./15 mm	.256 in./6.5 mm	8.0 GHP	18.0 lbs.
TX1508G6	3.0 GPM	3000 PSI	3400 RPM	.591 in./15 mm	.315 in./8.0 mm	9.2 GHP	18.0 lbs.

TX Series 63, Triplex Plunger Pump, 1" Hollow Shaft, Flanged for Direct Couple to Gasoline Engines (SAE J609B) – Large, lightweight connecting rods, new long life low-and high-pressure seals, oversized roller bearings and dual sight glasses. Forged brass manifold with an exclusive lifetime warranty.

**Max. Inlet Pressure: 125 PSI Max. Fluid Temperature: 165° F Inlet Port Thread: 1/2" - 14 BSP-F**

**Discharge Port Thread: 3/8" - 19 BSP-F Shaft Diameter: 1.0 in./25.4 mm**

**Pump Dimensions: 8.4" x 8.3" x 4.8" Max. Inlet Required: Flooded Crankcase Oil Capacity: 14 oz.**

**Use GP Series 100 Oil, (see page 57) Product Group: W**

	GPM	PSI	RPM	BORE	STROKE	HP	SHP WGHT
TX1506G8	2.6 GPM	3000 PSI	3400 RPM	.591 in./15 mm	.256 in./6.5 mm	8.0 GHP	18.0 lbs.
TX1508G8	3.0 GPM	3000 PSI	3400 RPM	.591 in./15 mm	.315 in./8.0 mm	9.2 GHP	18.0 lbs.
TX1509G8	3.5 GPM	3000 PSI	3400 RPM	.591 in./15 mm	.355 in./9.0 mm	10.8 GHP	18.0 lbs.
TX1510G8	4.0 GPM	3000 PSI	3400 RPM	.591 in./15 mm	.394 in./10 mm	12.3 GHP	18.0 lbs.

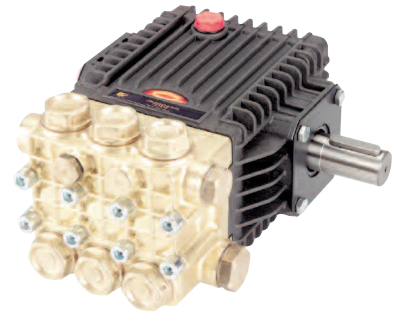

TX1812S17

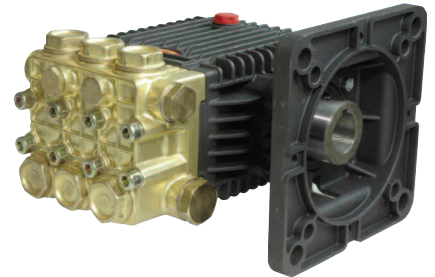

TX1512E179



TX1506G6

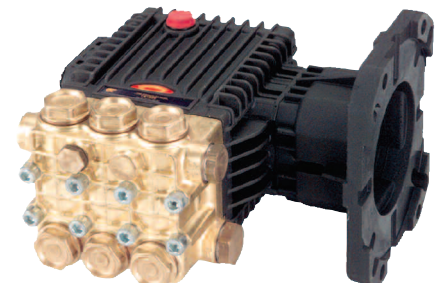

TX1506G8

# PRESSURE CLEANING PUMPS

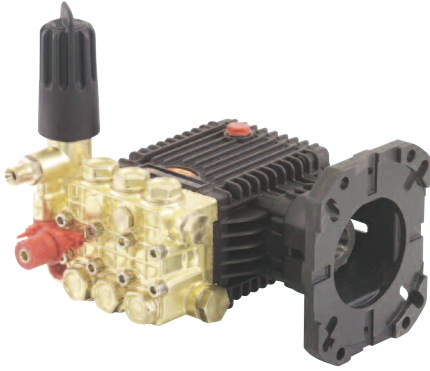

**TX1508G8UI**

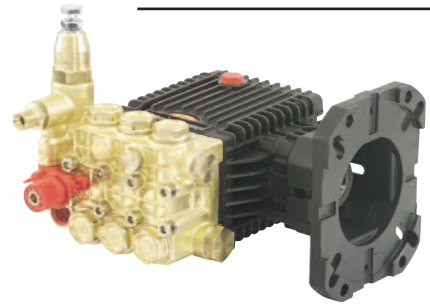

**TX1506G8UK**

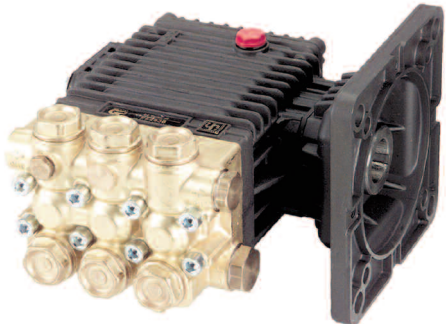

**EZ2536E**



**EZ2542S**

TX Series 63, Triplex Plunger Pump with Built-in Unloader and Downstream Injector on the left side of the manifold, 1" Hollow Shaft, Flanged for Direct Couple to Gasoline Engines (SAE J609B) – Large, lightweight connecting rods, new long life low-and high-pressure seals, oversized roller bearings and dual sight glasses. Forged brass manifold with an exclusive lifetime warranty.  
**Max. Inlet Pressure: 125 PSI Max. Fluid Temperature: 165° F Inlet Port Thread: 1/2" - 14 BSP-F Discharge Port Thread: 3/8" - 19 BSP-M Shaft Diameter: 1.0 in./25.4 mm**  
**Pump Dimensions: 8.4" x 8.3" x 4.8" Max. Inlet Required: Flooded**  
**Crankcase Oil Capacity: 14 oz. Use GP Series 100 Oil, (see page 57) Product Group: W**

	GPM	PSI	RPM	BORE	STROKE	HP	SHP WGHT
TX1506G8UI	2.6 GPM	3000 PSI	3400 RPM	.591 in./15 mm	.256 in./6.5 mm	8.0 GHP	18.2 lbs.
TX1508G8UI	3.0 GPM	3000 PSI	3400 RPM	.591 in./15 mm	.315 in./8.0 mm	9.2 GHP	18.2 lbs.
TX1509G8UI	3.5 GPM	3000 PSI	3400 RPM	.591 in./15 mm	.355 in./9.0 mm	10.8 GHP	18.2 lbs.
TX1510G8UI	4.0 GPM	3000 PSI	3400 RPM	.591 in./15 mm	.394 in./10 mm	12.3 GHP	18.2 lbs.

**Pump with Built-in Flow Sensitive Unloader and Fixed Downstream Injector**

TX1506G8UK	2.6 GPM	3000 PSI	3400 RPM	.591 in./15 mm	.256 in./6.5 mm	8.0 GHP	18.2 lbs.
TX1508G8UK	3.0 GPM	3000 PSI	3400 RPM	.591 in./15 mm	.315 in./8.0 mm	9.2 GHP	18.2 lbs.
TX1509G8UK	3.5 GPM	3000 PSI	3400 RPM	.591 in./15 mm	.355 in./9.0 mm	10.8 GHP	18.2 lbs.
TX1510G8UK	4.0 GPM	3000 PSI	3400 RPM	.591 in./15 mm	.394 in./10 mm	12.3 GHP	18.2 lbs.

EZ Series 44, Triplex Plunger Pump with Hollow Shaft, Flanged for Direct Couple to Electric Motors (NEMA-184TC) – Forged brass manifold with an exclusive lifetime warranty.

**Max. Inlet Pressure: 125 PSI Max. Fluid Temperature: 165° F Inlet Port Thread: 1/2" - 14 BSP-F Discharge Port Thread: 3/8" - 19 BSP-F Shaft Diameter: 1.125 in./28.5 mm**  
**Pump Dimensions: 8.8" x 8.8" x 6.3" Max. Inlet Vacuum: 3 ft. water (2.6 in. Hg)**  
**Crankcase Oil Capacity: 14.0 oz. Use GP Series 100 Oil, (see page 57) Product Group: W**

	GPM	PSI	RPM	BORE	STROKE	HP	SHP WGHT
EZ2536E	3.6 GPM	2500 PSI	1750 RPM	.708 in./18 mm	.433 in./11 mm	6.2 EBHP	18.5 lbs.
EZ2542E	4.2 GPM	2500 PSI	1750 RPM	.708 in./18 mm	.512 in./13 mm	7.2 EBHP	18.5 lbs.
EZ2545E	4.6 GPM	2500 PSI	3400 RPM	.591 in./15 mm	.433 in./11 mm	7.9 EBHP	18.5 lbs.
EZ2555E	5.5 GPM	2500 PSI	3400 RPM	.591 in./15 mm	.512 in./13 mm	9.4 EBHP	18.5 lbs.
EZ4035E34	3.5 GPM	4000 PSI	3400 RPM	.512 in./13 mm	.433 in./11 mm	9.6 EBHP	18.5 lbs.
EZ4040E34	4.0 GPM	4000 PSI	3400 RPM	.512 in./13 mm	.512 in./13 mm	11.0 EBHP	18.5 lbs.

**Pump Includes Unloader and Downstream Injector**

EZ2536EUI	3.6 GPM	2500 PSI	1750 RPM	.708 in./18 mm	.433 in./11 mm	6.2 EBHP	18.5 lbs.
-----------	---------	----------	----------	----------------	----------------	----------	-----------

EZ Series 44, Triplex Plunger Pump with Solid Shaft – Forged brass manifold with an exclusive lifetime warranty. Flex coupling and bell housing available for direct drive.

**Max. Inlet Pressure: 125 PSI Max. Fluid Temperature: 165° F Inlet Port Thread: 1/2" - 14 BSP-F Discharge Port Thread: 3/8" - 19 BSP-F Shaft Diameter: .945 in./24 mm**  
**Pump Dimensions: 8.6" x 8.7" x 5.5" Max. Inlet Vacuum: 3 ft. water (2.6 in. Hg)**  
**Crankcase Oil Capacity: 14.0 oz. Use GP Series 100 Oil, (see page 57) Product Group: W**

	GPM	PSI	RPM	BORE	STROKE	HP	SHP WGHT
EZ2536S	3.6 GPM	2500 PSI	1750 RPM	.708 in./18 mm	.433 in./11 mm	6.2 EBHP	18.0 lbs.
EZ3040S	4.0 GPM	3000 PSI	3400 RPM	.591 in./15 mm	.374 in./9.5 mm	8.2 EBHP	18.0 lbs.
EZ2542S	4.2 GPM	2500 PSI	1750 RPM	.708 in./18 mm	.512 in./13 mm	7.2 EBHP	18.0 lbs.
EZ2545S	4.6 GPM	2500 PSI	3400 RPM	.591 in./15 mm	.433 in./11 mm	7.9 EBHP	18.0 lbs.
EZ2555S	5.5 GPM	2500 PSI	3400 RPM	.591 in./15 mm	.512 in./13 mm	9.4 EBHP	18.0 lbs.

**Premium Roller Bearings**

EZ3042S	4.2 GPM	3000 PSI	1750 RPM	.708 in./18 mm	.512 in./13 mm	8.6 EBHP	18.0 lbs.
---------	---------	----------	----------	----------------	----------------	----------	-----------

**Pump Includes Built-in Unloader and Downstream Injector**

EZ2530SUI	3.0 GPM	2500 PSI	1750 RPM	.591 in./15 mm	.512 in./13 mm	5.1 EBHP	19.0 lbs.
-----------	---------	----------	----------	----------------	----------------	----------	-----------

**1-800-346-4876**

# PRESSURE CLEANING PUMPS

EZ Series 44, Triplex Plunger Pump with Hollow Shaft, Flanged for Direct Couple to Gasoline Engines (SAE J609B) – Forged brass manifold with an exclusive lifetime warranty. Flanged for mounting on up to 13 horsepower engines.

**Max. Inlet Pressure: 125 PSI Max. Fluid Temperature: 165° F Inlet Port Thread: 1/2" - 14 BSP-F**

**Discharge Port Thread: 3/8" - 19 BSP-F Shaft Diameter: 1.0 in./25.4 mm**

**Pump Dimensions: 8.8" x 9.7" x 6.5" Max. Inlet Vacuum: 3 ft. water (2.6 in. Hg)**

**Crankcase Oil Capacity: 14.0 oz. Use GP Series 100 Oil, (see page 57) Product Group: W**

	GPM	PSI	RPM	BORE	STROKE	HP	SHP WGHT
EZ3030G34	3.0 GPM	3200 PSI	3400 RPM	.591 in./15 mm	.299 in./7.6 mm	9.9 GHP	19.1 lbs.
EZ3035G	3.5 GPM	3000 PSI	3400 RPM	.591 in./15 mm	.335 in./8.5 mm	10.8 GHP	19.1 lbs.
EZ3040G	4.0 GPM	3000 PSI	3400 RPM	.591 in./15 mm	.374 in./9.5 mm	12.3 GHP	19.1 lbs.
EZ3045G	4.6 GPM	3000 PSI	3400 RPM	.591 in./15 mm	.433 in./11 mm	14.2 GHP	19.1 lbs.

**Max. Inlet Required: Flooded**

EZ4030G34	3.0 GPM	4000 PSI	3400 RPM	.512 in./13 mm	.374 in./9.5 mm	12.3 GHP	20.0 lbs.
EZ4035G34	3.5 GPM	4000 PSI	3400 RPM	.512 in./13 mm	.433 in./11 mm	14.4 GHP	20.0 lbs.
EZ4040G	4.0 GPM	4000 PSI	3400 RPM	.512 in./13 mm	.512 in./13 mm	16.4 GHP	20.0 lbs.

**Pump with Built-in Unloader and Fixed Downstream Injector**

EZ3030G34UI	3.0 GPM	3500 PSI	3400 RPM	.591 in./15 mm	.299 in./7.6 mm	10.8 GHP	19.3 lbs.
EZ3035GUI	3.5 GPM	3500 PSI	3400 RPM	.591 in./15 mm	.335 in./8.5 mm	12.6 GHP	19.3 lbs.
EZ3040GUI	4.0 GPM	3500 PSI	3400 RPM	.591 in./15 mm	.374 in./9.5 mm	14.4 GHP	19.3 lbs.
EZ2545GUI	4.6 GPM	2500 PSI	3400 RPM	.591 in./15 mm	.433 in./11 mm	11.8 GHP	19.3 lbs.

**Pump with Built-in Flow Sensitive Unloader and Fixed Downstream Injector**

EZ3035GUK	3.5 GPM	3000 PSI	3400 RPM	.591 in./15 mm	.335 in./8.5 mm	10.8 GHP	19.3 lbs.
EZ3040GUK	4.0 GPM	3000 PSI	3400 RPM	.591 in./15 mm	.374 in./9.5 mm	12.3 GHP	19.3 lbs.

T Series 50, Triplex Plunger Pump with Solid Shaft – Forged brass manifold with an exclusive lifetime warranty. Flex coupling and bell housing available for direct drive. Solid ceramic plungers with continuously lubricated packings.

**Max. Inlet Pressure: 125 PSI Max. Fluid Temperature: 165° F Inlet Port Thread: 1/2" - 14 BSP-F**

**Discharge Port Thread: 3/8" - 19 BSP-F Shaft Diameter: .945 in./24 mm**

**Pump Dimensions: 9.3" x 8.3" x 5.4" Max. Inlet Vacuum: 9 ft. water (7.9 in. Hg)**

**Crankcase Oil Capacity: 15.2 oz. Use GP Series 100 Oil, (see page 57) Product Group: W**

	GPM	PSI	RPM	BORE	STROKE	HP	SHP WGHT
T991	3.5 GPM	1500 PSI	1450 RPM	.787 in./20 mm	.394 in./10 mm	3.6 EBHP	19.0 lbs.
T9951	3.5 GPM	1500 PSI	1750 RPM	.787 in./20 mm	.335 in./8.5 mm	3.6 EBHP	19.0 lbs.
TT9351	3.5 GPM	2500 PSI	3400 RPM	.591 in./15 mm	.335 in./8.5 mm	6.0 EBHP	18.7 lbs.
T991	4.0 GPM	1100 PSI	1750 RPM	.787 in./20 mm	.394 in./10 mm	3.0 EBHP	19.0 lbs.
T9971*	4.0 GPM	2000 PSI	1750 RPM	.787 in./20 mm	.394 in./10 mm	5.5 EBHP	19.0 lbs.
*The T9971 uses GP Series 8090 Oil.							
TT9441	4.4 GPM	2500 PSI	3400 RPM	.591 in./15 mm	.394 in./10 mm	7.5 EBHP	18.7 lbs.

**T991 (100648) and T9951 (100656) with Teflon Packings**

100648	3.5 GPM	1500 PSI	1450 RPM	.787 in./20 mm	.394 in./10 mm	3.6 EBHP	19.0 lbs.
100656	3.5 GPM	1500 PSI	1750 RPM	.787 in./20 mm	.335 in./8.5 mm	3.6 EBHP	19.0 lbs.

**Pump with Gearbox**

T991GR	3.5 GPM	1500 PSI	3400 RPM	.787 in./20 mm	.394 in./10 mm	5.4 GHP	24.0 lbs.
T9971GR	3.5 GPM	2000 PSI	3400 RPM	.787 in./20 mm	.394 in./10 mm	7.2 GHP	24.0 lbs.

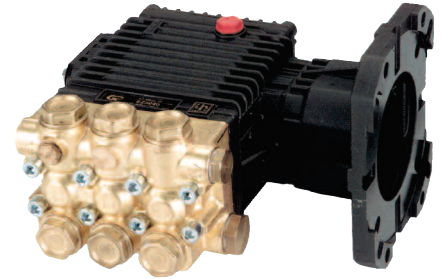

**EZ3040G**

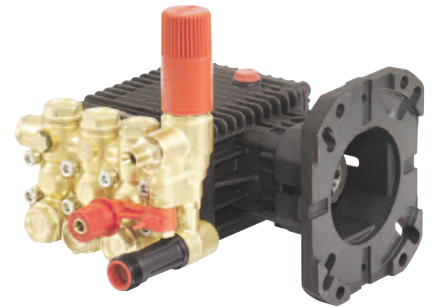

**EZ3040GUI**

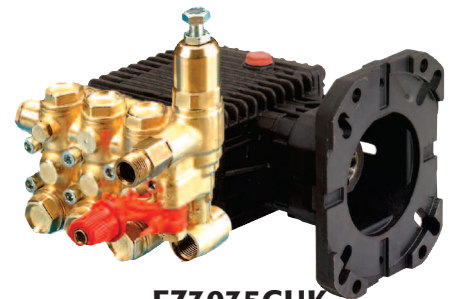

**EZ3035GUK**



**T991**

# PRESSURE CLEANING PUMPS



**TS1331**

T Series 47, Triplex Plunger Pump, Solid Shaft – Forged brass manifold with an exclusive lifetime warranty. Heavy-duty tapered roller bearings and oversized connecting rods for maximum life.  
**Max. Inlet Pressure: 125 PSI Max. Fluid Temperature: 165° F Inlet Port Thread: 1/2" - 14 BSP-F**  
**Discharge Port Thread: 3/8" - 19 BSP-F Shaft Diameter: .945 in./24 mm**  
**Pump Dimensions: 12.2" x 9.2" x 6.9" Max. Inlet Vacuum: 9 ft. water (7.9 in. Hg)**  
**Crankcase Oil Capacity: 33.8 oz. Use GP Series 100 Oil, (see page 57) Product Group: X**

	GPM	PSI	RPM	BORE	STROKE	HP	SHP WGHT
TS1331	3.5 GPM	2100 PSI	1450 RPM	.787 in./20 mm	.394 in./10 mm	5.0 EBHP	32.0 lbs.
TS1011	4.0 GPM	2000 PSI	1450 RPM	.787 in./20 mm	.472 in./12 mm	5.5 EBHP	32.0 lbs.
TS1331	4.0 GPM	2000 PSI	1750 RPM	.787 in./20 mm	.394 in./10 mm	5.5 EBHP	32.0 lbs.
T1011	4.5 GPM	2000 PSI	1125 RPM	.787 in./20 mm	.630 in./16 mm	6.2 EBHP	32.0 lbs.
TS1011*	4.75 GPM	1500 PSI	1750 RPM	.787 in./20 mm	.472 in./12 mm	4.9 EBHP	32.0 lbs.
TS921	4.75 GPM	1800 PSI	1450 RPM	.866 in./22 mm	.472 in./12 mm	5.9 EBHP	32.0 lbs.
T921	5.0 GPM	1700 PSI	1050 RPM	.866 in./22 mm	.630 in./16 mm	5.8 EBHP	32.0 lbs.
T1011	5.6 GPM	1500 PSI	1450 RPM	.787 in./20 mm	.630 in./16 mm	5.8 EBHP	32.0 lbs.

**Max. Inlet Pressure: 125 PSI Max. Fluid Temperature: 165° F Inlet Port Thread: 1/2" - 14 BSP-F**  
**Discharge Port Thread: 3/8" - 19 BSP-F Shaft Diameter: .945 in./24 mm**  
**Pump Dimensions: 12.6" x 9.2" x 6.9" Max. Inlet Vacuum: 9 ft. water (7.9 in. Hg)**  
**Crankcase Oil Capacity: 40.6 oz. Use GP Series 100 Oil, (see page 57) Product Group: X**

	GPM	PSI	RPM	BORE	STROKE	HP	SHP WGHT
TS1711*	3.5 GPM	2700 PSI	1450 RPM	.787 in./20 mm	.394 in./10 mm	6.5 EBHP	32.0 lbs.
TS1511*	4.0 GPM	3500 PSI	1450 RPM	.787 in./20 mm	.472 in./12 mm	9.6 EBHP	32.0 lbs.
TS1021	4.5 GPM	3000 PSI	1125 RPM	.787 in./20 mm	.630 in./16 mm	9.2 EBHP	32.0 lbs.
TS1321*	4.75 GPM	2100 PSI	1450 RPM	.866 in./22 mm	.472 in./12 mm	6.8 EBHP	32.0 lbs.
T1621	5.0 GPM	2500 PSI	1050 RPM	.866 in./22 mm	.630 in./16 mm	8.6 EBHP	32.0 lbs.
T1321	5.5 GPM	2100 PSI	1150 RPM	.866 in./22 mm	.630 in./16 mm	7.9 EBHP	32.0 lbs.
TS1021	5.6 GPM	1700 PSI	1450 RPM	.787 in./20 mm	.630 in./16 mm	6.5 EBHP	32.0 lbs.
TS1811	4.5 GPM	3500 PSI	1450 RPM	.787 in./20 mm	.551 in./14 mm	10.8 EBHP	32.0 lbs.
TS1811	4.0 GPM	3500 PSI	1290 RPM	.787 in./20 mm	.551 in./14 mm	10.0 EBHP	32.0 lbs.

T Series 47, Triplex Plunger Pump, Solid Shaft – Nickel-plated forged brass manifold with an exclusive lifetime warranty. Heavy-duty tapered roller bearings and oversized connecting rods for maximum life.

**Max. Inlet Pressure: 125 PSI Max. Fluid Temperature: 165° F Inlet Port Thread: 1/2" - 14 BSP-F**  
**Discharge Port Thread: 3/8" - 19 BSP-F Shaft Diameter: .945 in./24 mm**  
**Pump Dimensions: 12.6" x 9.2" x 6.9" Max. Inlet Vacuum: 9 ft. water (7.9 in. Hg)**  
**Crankcase Oil Capacity: 40.6 oz. Use GP Series 100 Oil, (see page 57) Product Group: X**

	GPM	PSI	RPM	BORE	STROKE	HP	SHP WGHT
T9211	4.0 GPM	3000 PSI	1750 RPM	.787 in./20 mm	.394 in./10 mm	8.2 EBHP	32.0 lbs.
TS2011	4.0 GPM	3500 PSI	1450 RPM	.787 in./20 mm	.472 in./12 mm	9.6 EBHP	32.0 lbs.
TS2021	4.5 GPM	3500 PSI	1125 RPM	.787 in./20 mm	.630 in./16 mm	10.8 EBHP	32.0 lbs.
TS1621*	4.75 GPM	2500 PSI	1450 RPM	.866 in./22 mm	.472 in./12 mm	8.1 EBHP	32.0 lbs.
TS2011*	4.75 GPM	2300 PSI	1750 RPM	.787 in./20 mm	.394 in./12 mm	7.5 EBHP	32.0 lbs.
TS2021*	5.6 GPM	3500 PSI	1450 RPM	.787 in./20 mm	.630 in./16 mm	13.4 EBHP	32.0 lbs.
T9281	4.0 GPM	4000 PSI	1750 RPM	.630 in./16 mm	.630 in./16 mm	11.0 EBHP	33.0 lbs.

New High Flow 47 Series, Triplex Plunger Pump, Solid Shaft - Forged brass manifold with larger valves to accommodate increased flow. Heavy duty tapered roller bearings and oversized connecting rods for maximum life.

**Max. Inlet Pressure: 125 PSI Max. Fluid Temperature: 165° F Inlet Port Thread: 3/4" - 14 BSP-F**  
**Discharge Port Thread: 3/8" - 19 BSP-F Shaft Diameter: .945 in./24 mm**  
**Pump Dimensions: 13.1" x 10.2" x 7.1" Max. Inlet Vacuum: 9 ft. water (7.9 in. Hg)**  
**Crankcase Oil Capacity: 40.6 oz. Use GP Series 100 Oil, (see page 57) Product Group: X**

	GPM	PSI	RPM	BORE	STROKE	HP	SHP WGHT
TS2219	7.7 GPM	2320 PSI	1450 RPM	.866 in./22 mm	.748 in./19 mm	12.5 EBHP	360 lbs.

\*Pumps are available with 1" Gearbox for mounting to J609B gas engines.

# PRESSURE CLEANING PUMPS

66 Series, Triplex Plunger Pump – Forged brass manifold with an exclusive lifetime warranty. Innovative seal design to extend seal life. Plunger design improves thermal shock resistance. New valve cap design improves hydrostatic performance.

**Max. Inlet Pressure: 125 PSI Max. Fluid Temperature: 165° F Inlet Port Thread: 3/4" - 14 BSP-F**  
**Discharge Port Thread: 3/8" - 19 BSP-F Shaft Diameter: .945 in./24 mm**  
**Pump Dimensions: 13.27" x 9.6" x 6.23" Max. Inlet Vacuum: 9 ft. water (7.9 in. Hg)**  
**Crankcase Oil Capacity: 40.6 oz. Use GP Series 100 Oil, (see page 57) Product Group: X**

	GPM	PSI	RPM	BORE	STROKE	HP	SHP WGHT
TSF1819	6.3 GPM	4350 PSI	1750 RPM	.709 in./18 mm	.748 in./19 mm	18.8 EBHP	40.7 lbs.
TSF2019	6.3 GPM	3600 PSI	1450 RPM	.787 in./20 mm	.748 in./19 mm	15.5 EBHP	40.7 lbs.
TSF2021	7.0 GPM	3600 PSI	1450 RPM	.787 in./20 mm	.826 in./21 mm	17.3 EBHP	40.7 lbs.
TSF2019	7.6 GPM	3600 PSI	1750 RPM	.787 in./20 mm	.748 in./19 mm	18.7 EBHP	40.7 lbs.
TSF2219	7.7 GPM	3000 PSI	1450 RPM	.866 in./22 mm	.748 in./19 mm	15.8 EBHP	40.7 lbs.
TSF2021	8.5 GPM	3600 PSI	1750 RPM	.787 in./20 mm	.826 in./21 mm	21.0 EBHP	40.7 lbs.
TSF2221	8.5 GPM	3000 PSI	1450 RPM	.866 in./22 mm	.826 in./21 mm	17.5 EBHP	40.7 lbs.
TSF2219	9.3 GPM	3000 PSI	1750 RPM	.866 in./22 mm	.748 in./19 mm	19.1 EBHP	40.7 lbs.
TSF2421	10.0 GPM	2500 PSI	1450 RPM	.945 in./24 mm	.826 in./21 mm	17.1 EBHP	40.7 lbs.
TSF2221	10.2 GPM	3000 PSI	1750 RPM	.866 in./22 mm	.826 in./21 mm	21.0 EBHP	40.7 lbs.
TSF2819	12.1 GPM	2200 PSI	1450 RPM	1.102 in./28 mm	.748 in./19 mm	18.2 EBHP	40.7 lbs.
TSF2421	12.0 GPM	2500 PSI	1750 RPM	.945 in./24 mm	.826 in./21 mm	20.5 EBHP	40.7 lbs.

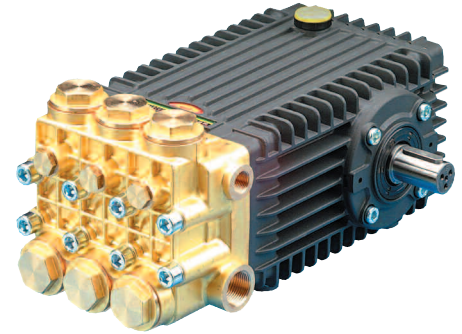

**TSF1819**

66 Series, Triplex Plunger Pump, High Pressure – Forged brass manifold with an exclusive lifetime warranty. Innovative seal design to extend seal life. Plunger design improves thermal shock resistance. New valve cap design improves hydrostatic performance.

**Max. Inlet Pressure: 125 PSI Max. Fluid Temperature: 165° F Inlet Port Thread: 1/2" - 14 BSP-F**  
**Discharge Port Thread: 3/8" - 19 BSP-F Shaft Diameter: .945 in./24 mm**  
**Pump Dimensions: 13.84" x 9.8" x 7.7" Min. Inlet Pressure: 30 PSI**  
**Crankcase Oil Capacity: 40.6 oz. Use GP Series 100 Oil, (see page 57) Product Group: X**

	GPM	PSI	RPM	BORE	STROKE	HP	SHP WGHT
TSP1619	3.6 GPM	7250 PSI	1450 RPM	.629 in./16 mm	.748 in./19 mm	17.8 EBHP	51.8 lbs.
TSP1619	4.3 GPM	5800 PSI	1750 RPM	.629 in./16 mm	.748 in./19 mm	17.8 EBHP	51.8 lbs.
TSP1621	4.3 GPM	6525 PSI	1450 RPM	.630 in./16 mm	.826 in./21 mm	17.1 EBHP	51.8 lbs.
TSP1819	5.0 GPM	5100 PSI	1450 RPM	.709 in./18 mm	.748 in./19 mm	17.1 EBHP	51.8 lbs.
TSP1821	5.5 GPM	5100 PSI	1450 RPM	.709 in./18 mm	.826 in./21 mm	18.8 EBHP	51.8 lbs.



**TSP1619**

T Series 69, Triplex Plunger Pump, Solid Shaft – The industry's choice for high-flow applications. Ball bearings and oversized connecting rods for maximum life.

**Max. Inlet Pressure: 125 PSI Max. Fluid Temperature: 165° F Inlet Port Thread: 3/4" - 14 BSP-F**  
**Discharge Port Thread: 3/8" - 19 BSP-F Shaft Diameter: 1.378 in./35 mm**  
**Pump Dimensions: 12.9" x 11.9" x 7.3" Max. Inlet Vacuum: 9 ft. water (7.9 in. Hg)**  
**Crankcase Oil Capacity: 50.7 oz. Use GP Series 8090 Oil, (see page 57) Product Group: Y**

	GPM	PSI	RPM	BORE	STROKE	HP	SHP WGHT
TS1531	7.92 GPM	2175 PSI	1450 RPM	.787 in./20 mm	.866 in./22 mm	11.8 EBHP	46.0 lbs.
TS1041	8.0 GPM	1600 PSI	1450 RPM	.787 in./20 mm	.866 in./22 mm	8.8 EBHP	46.0 lbs.
T41	12.0 GPM	900 PSI	650 RPM	1.417 in./36 mm	.945 in./24 mm	7.4 EBHP	37.0 lbs.



**T41**

T Series 76, Triplex Plunger Pump, Solid Shaft – Forged brass manifold with an exclusive lifetime warranty. The industry's choice for high-flow applications, oversized connecting rods for maximum life.

**Max. Inlet Pressure: 125 PSI Max. Fluid Temperature: 165° F Inlet Port Thread: 1" NPT-F**  
**Discharge Port Thread: 1/2" NPT-F Shaft Diameter: 1.378 in./35 mm**  
**Pump Dimensions: 15.6" x 14.0" x 9.5" Max. Inlet Vacuum: 7 ft. water (6.2 in. Hg)**  
**Crankcase Oil Capacity: 91.0 oz. Use GP Series 8090 Oil, (see page 57) Product Group: Y**

	GPM	PSI	RPM	BORE	STROKE	HP	SHP WGHT
T4251	6.6 GPM	5800 PSI	1000 RPM	.787 in./20 mm	1.102 in./28 mm	26.2 EBHP	160 lbs.
T1551	14.0 GPM	2175 PSI	1000 RPM	1.181 in./30 mm	1.102 in./28 mm	20.9 EBHP	93.0 lbs.



**T4251**



# PRESSURE CLEANING PUMPS



**T61**

T Series 76, Triplex Plunger Pump, Solid Shaft – Forged brass manifold with an exclusive lifetime warranty. The industry's choice for high-flow applications, oversized connecting rods for maximum life.

**Max. Inlet Pressure: 125 PSI Max. Fluid Temperature: 165° F Inlet Port Thread: 1" - 11 BSP-F**  
**Discharge Port Thread: 3/4" - 14 BSP-F Shaft Diameter: 1.378 in./35 mm**  
**Pump Dimensions: 15.6" x 14.0" x 9.5" Max. Inlet Vacuum: 9 ft. water (7.9 in. Hg)**  
**Crankcase Oil Capacity: 91.0 oz. Use GP Series 8090 Oil, (see page 57) Product Group: Y**

	GPM	PSI	RPM	BORE	STROKE	HP	SHP WGHT
T61	17.0 GPM	1000 PSI	650 RPM	1.772 in./45 mm	.945 in./24 mm	11.6 EBHP	92.0 lbs.
T81	21.0 GPM	1000 PSI	650 RPM	1.772 in./45 mm	1.102 in./28 mm	14.4 EBHP	92.0 lbs.



**T1631**

T Series 48, Sixplex Plunger Pump – Forged brass manifold with an exclusive lifetime warranty. Dual manifolds utilizing a common crankcase for efficient performance in high-flow applications.

**Max. Inlet Pressure: 125 PSI Max. Fluid Temperature: 165° F Inlet Port Thread: Dual 3/4" - 14 BSP-F**  
**Discharge Port Thread: Dual 3/8" - 19 BSP-F Shaft Diameter: 1.26 in./32 mm**  
**Pump Dimensions: 16.1" x 11.2" x 7.9" Max. Inlet Vacuum: 9 ft. water (7.9 in. Hg)**  
**Crankcase Oil Capacity: 54.0 oz. Use GP Series 100 Oil, (see page 57) Product Group: Y**

	GPM	PSI	RPM	BORE	STROKE	HP	SHP WGHT
T2031	9.0 GPM	3000 PSI	1140 RPM	.787 in./20 mm	.630 in./16 mm	18.5 EBHP	61.0 lbs.
T1631	10.0 GPM	2500 PSI	1080 RPM	.866 in./22 mm	.630 in./16 mm	17.1 EBHP	61.0 lbs.
T2031	11.0 GPM	2000 PSI	1450 RPM	.787 in./20 mm	.630 in./16 mm	15.1 EBHP	61.0 lbs.



**T121**

T Series 77, Sixplex Plunger Pump – Forged brass manifold with an exclusive lifetime warranty. Dual manifolds utilizing a common crankcase for efficient performance in high flow applications.

**Max. Inlet Pressure: 125 PSI Max. Fluid Temperature: 165° F Inlet Port Thread: Dual 1" - 11 BSP-F**  
**Discharge Port Thread: Dual 3/4" - 14 BSP-F Shaft Diameter: 1.378 in./35 mm**  
**Pump Dimensions: 22.1" x 14.0" x 9.7" Max. Inlet Vacuum: 9 ft. water (7.9 in. Hg)**  
**Crankcase Oil Capacity: 71.0 oz. Use GP Series 8090 Oil, (see page 57) Product Group: Y**

	GPM	PSI	RPM	BORE	STROKE	HP	SHP WGHT
T1591	28.0 GPM	2175 PSI	1000 RPM	1.181 in./30 mm	1.102 in./28 mm	41.7 EBHP	156 lbs.
T121	35.0 GPM	1000 PSI	650 RPM	1.772 in./45 mm	.945 in./24 mm	24.0 EBHP	156 lbs.
T151	43.0 GPM	1000 PSI	650 RPM	1.772 in./45 mm	1.102 in./28 mm	29.5 EBHP	156 lbs.

# PRESSURE CLEANING PUMPS

T Series 77, Sixplex Plunger Pump – Nickel-plated forged brass manifold with an exclusive lifetime warranty. Dual manifold utilizing a common crankcase for efficient performance. Unique “in-line” valve system for easy access and durability.

**Max. Inlet Pressure: 125 PSI Max. Fluid Temperature: 165° F Inlet Port Thread: Dual 1" - 11 BSP-F**  
**Discharge Port Thread: Dual 1/2" - 14 BSP-F Shaft Diameter: 1.378 in./35 mm**  
**Pump Dimensions: 25.2" x 14.0" x 10.0" Max. Inlet Vacuum: 7 ft. water (6.2 in. Hg)**  
**Crankcase Oil Capacity: 71.0 oz. Use GP Series 8090 Oil, (see page 57) Product Group: Y**

	GPM	PSI	RPM	BORE	STROKE	HP	SHP WGHT
T3551	13.0 GPM	4350 PSI	1000 RPM	.787 in./20 mm	1.102 in./20 mm	38.7 EBHP	174 lbs.

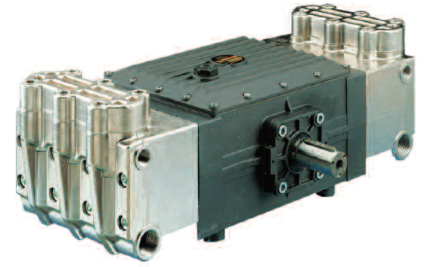

**T3551**

AT Series 75 Duplex Plunger Pump, Splined Shaft – Ideal for drain cleaning and jetting applications. Aluminum manifold and solid ceramic plungers with continuously lubricated packings. (All splined shaft pumps require additional components to attach to PTO Systems).

**Max. Inlet Pressure: 125 PSI Max. Fluid Temperature: 165° F Inlet Port Thread: 3/4" - 14 BSP-F**  
**Discharge Port Thread: 3/8" - 19 BSP-F Shaft Diameter: 1.375 in./34.9 mm ASAE**  
**Pump Dimensions: 12" x 9" x 7.3" Use GP Series 100 Oil, (see page 57) Product Group: Y**

	GPM	PSI	RPM	BORE	STROKE	OIL CAPACITY	HP	SHP WGHT
AT0033	7.93 GPM	435 PSI	650 RPM	1.417 in./36 mm	.945 in./24 mm	22 oz.	2.4 EBHP	28.0 lbs.



**AT0055**

**Shaft Diameter: 1.375 in./34.9 mm ASAE splined Pump Dimensions: 13" x 14" x 7.5"**

	GPM	PSI	RPM	BORE	STROKE	OIL CAPACITY	HP	SHP WGHT
AT0055	13.22 GPM	725 PSI	650 RPM	1.417 in./36 mm	.945 in./24 mm	51 oz.	6.6 EBHP	36.0 lbs.

Aluminum or a forged brass manifold. Heavy-duty tapered roller bearings and oversized connecting rods for maximum life.

**Shaft Diameter: 1.375 in./34.9 mm ASAE splined Pump Dimensions: 15.6" x 14" x 9.5"**

	GPM	PSI	RPM	BORE	STROKE	OIL CAPACITY	HP	SHP WGHT
AT0088	22.48 GPM	870 PSI	650 RPM	1.771 in./45 mm	1.102 in./28 mm	61 oz.	13.4 EBHP	85.0 lbs.
AT0088B	22.48 GPM	870 PSI	650 RPM	1.771 in./45 mm	1.102 in./28 mm	61 oz.	13.4 EBHP	92.0 lbs.

AT Series 77 Sixplex Plunger Pump, Splined Shaft – Aluminum or a forged brass manifold. Dual manifolds utilizing a common crankcase for efficient performance and bronze connecting rods for maximum life.

**Inlet Port Thread: 1" - 11 BSP-F Discharge Port Thread: 3/4" - 14 BSP-F**  
**Shaft Diameter: 1.375 in./34.9 mm ASAE splined Pump Dimensions: 21" x 17" x 9.5" Use GP Series 100 Oil, (see page 57)**

	GPM	PSI	RPM	BORE	STROKE	OIL CAPACITY	HP	SHP WGHT
AT0111	29.1 GPM	725 PSI	550 RPM	1.771 in./45 mm	.945 in./24 mm	71 oz.	14.5 EBHP	88.0 lbs.
AT0177	45.0 GPM	870 PSI	650 RPM	1.771 in./45 mm	1.102 in./28 mm	71 oz.	26.8 EBHP	88.0 lbs.
AT0177B	45.0 GPM	870 PSI	650 RPM	1.771 in./45 mm	1.102 in./28 mm	71 oz.	26.8 EBHP	156 lbs.

# EMPEROR PUMPS WITH HT TECHNOLOGY



**Emperor**  
Pumps That Rule Any Environment

## Automotive

- Municipal vehicle maintenance
- Bug and tar removal
- General exterior cleaning

## Self-service wash

- Single or multi-bay applications
- Spot-free rinse application
- Chemical application
- Pre-soak/Tire-motor cleaner
- Foam brush
- Reclaim water
- Weep-systems

## Automatic wash

- Roll-over automatic
- Spot-free rinse application
- Pre-soak systems

- Weep systems
- Foam application

## Tunnel wash

- Prep station
- Brush wetting
- Detergent application
- Spot-free rinse application
- Bay wash-down

## Mobile vehicle wash

- Truck mounted wash units
- Spot-free rinse application

## Household cleaning

- Carpet cleaning

## Household exterior cleaning

- Mildew removal
- Storm cleanup
- Pool decks
- Gutter cleaning

## Contract cleaning

- Building exterior cleaning
- Sidewalk cleaning
- Driveway cleaning
- Deck cleaning
- Restaurant kitchen cleaning
- Hood and duct cleaning
- Mobile vehicle wash
- Ice abatement
- Wet sandblasting
- General cleaning

## Emperor Pumps

Emperor HTC, 60 Series, Triplex plunger pump. Ideal for use in carpet cleaning and other high pressure cleaning applications. This pump offers a compact, economical design.

**Max. Inlet Pressure: 125 PSI Max. Fluid Temperature: 185° F Inlet Port Thread: 1/2" - 14 BSP-F**

**Discharge Port Thread: 3/8" - 19 BSP-F Shaft Diameter: .626 in./16 mm**

**Pump Dimensions: 7.8" x 7.3" x 5.5" Max. Inlet Vacuum: 3 ft. water (2.6 in. Hg)**

**Crankcase Oil Capacity: 11.8 oz. Use GP Series 100 Oil, (see page 57) Product Group: X**

	GPM	PSI	RPM	BORE	STROKE	HP	SHP WGHT
HTC1505E345	2.1	2200	3400	.591 in/15 mm	.197 in/5 mm	3.5	16 lbs.
HTC1509E175	2.1	2200	1750	.591 in/15 mm	.370 in/9.4 mm	3.5	16 lbs.

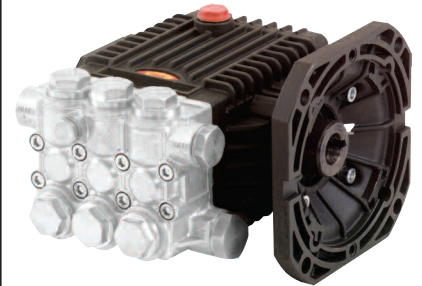

**HTC1509E175**

Emperor HTS, 47HT Series, Triplex plunger pump features exclusive HT technology. Specifically designed to handle the rigorous duty cycles, high temperatures and chemicals associated with self-service car wash applications. Also ideal for use in carpet cleaning and other high pressure cleaning applications.

**Max. Inlet Pressure: 125 PSI Max. Fluid Temperature: 185° F Inlet Port Thread: 1/2" - 14 BSP-F**

**Discharge Port Thread: 3/8" - 19 BSP-F Shaft Diameter: .945 in./24 mm**

**Pump Dimensions: 12.2" x 9.2" x 6.9" 12.4" x 10" x 6.9" (with rails) Max. Inlet Vacuum: 9 ft. water**

**(7.9 in. Hg) Crankcase Oil Capacity: 40.6 oz. Use GP Series 100 Oil, (see page 57) Product Group: X**

	GPM	PSI	RPM	BORE	STROKE	HP	SHP WGHT
HTS2210S	2.6/4.0	2300	950/1450	.866 in/22 mm	.394 in/10 mm	4.1/6.3	32 lbs.
HTS2212S	3.2/4.75	2300	950/1450	.866 in/22 mm	.472 in/12 mm	5/7.5	32 lbs.
HTS2215S	4.0/5.0	2300	950/1200	.866 in/22 mm	.591 in/15 mm	4.1/7.8	32 lbs.
HTS2016S	5.6	3000	1450	.787 in/20 mm	.630 in/16 mm	10.2	32 lbs.



**HTS2210S**

Emperor HTX, 63HT Series, Triplex plunger pump features exclusive HT technology. Specifically designed to handle the rigorous duty cycles, high temperatures and chemicals associated with self-service car wash applications. Also ideal for use in carpet cleaning and other high pressure cleaning applications. This pump offers a compact and economical design.

**Max. Inlet Pressure: 125 PSI Max. Fluid Temperature: 185° F Inlet Port Thread: 1/2" - 14 BSP-F**

**Discharge Port Thread: 3/8" - 19 BSP-F Shaft Diameter: .945 in./24 mm**

**Pump Dimensions: 8.4" x 8.3" x 4.8" 8.4" x 8.3" x 5.6" (with rails) Max. Inlet Vacuum: 3 ft. water**

**(2.6 in. Hg) Crankcase Oil Capacity: 14 oz. Use GP Series 100 Oil, (see page 57) Product Group: X**

	GPM	PSI	RPM	BORE	STROKE	HP	SHP WGHT
HTX1810S	2.7/3.1	2000	1450/1750	.709 in./18 mm	.394 in./10 mm	3.5/4.2	18 lbs.
HTX1812S	3.2/3.8	2000	1450/1750	.709 in./18 mm	.472 in./12 mm	4.3/5.2	18 lbs.
HTX1813S	3.5	2500	1450	.709 in./18 mm	.512 in./13 mm	6	18 lbs.



**HTX1810S**

## Emperor Pumps

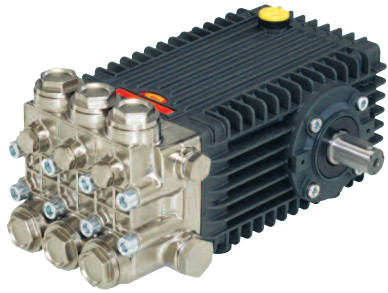

**HTF2018S**

Emperor HTF, 66HT Series, Triplex plunger pump features exclusive HT technology. Designed for use in prep units, conveyor and multiple gun applications. Excellent for carpet cleaning and for use in industrial plant systems where hot water is required.

**Max. Inlet Pressure: 125 PSI Max. Fluid Temperature: 185° F Inlet Port Thread: 3/4" - 14 BSP-F Discharge Port Thread: 3/8" - 19 BSP-F Shaft Diameter: .945 in./24 mm Pump Dimensions: 13.27" x 9.6" x 6.23" 13.4" x 9.8" x 7.5" (with rails) Max. Inlet Vacuum: 9 ft. water (7.9 in. Hg) Crankcase Oil Capacity: 31 oz. Use GP Series 100 Oil, (see page 57) Product Group: X**

	GPM	PSI	RPM	BORE	STROKE	HP	SHP WGHT
HTF2018S	4.0/5.0/7.5	3600	950/1200/1750	.787 in/20 mm	.748 in/18 mm	10/12/18.5	41 lbs.
HTF2221S	8.5/10.2	3000	1450/1750	.866 in/22 mm	.826 in/21 mm	17.5/21	41 lbs.
HTF2421S	10.0/12.0	3000/2500	1450/1750	.945 in/24 mm	.826 in/21 mm	20.5	41 lbs.



**HTW3624S**

Emperor HTW, 69HT Series, Triplex plunger pump features exclusive HT technology. Designed for touchless carwash systems, multiple gun systems and industrial plant systems where hot water is required.

**Max. Inlet Pressure: 125 PSI Max. Fluid Temperature: 185° F Inlet Port Thread: 1" - 11 BSP-F Discharge Port Thread: 3/4" - 14 BSP-F Shaft Diameter: 1.378 in./35 mm Pump Dimensions: 13" x 11.9" x 7.3" Max. Inlet Vacuum: 9 ft. water (7.9 in. Hg) Crankcase Oil Capacity: 50.7 oz. Use GP Series 100 Oil, (see page 57) Product Group: X**

	GPM	PSI	RPM	BORE	STROKE	HP	SHP WGHT
HTW3624S*	18.0	1200	1000	1.417 in/36 mm	.946 in/24 mm	19.5	57 lbs.



See page 48 for further details

**HTCK3623S**

Emperor HTCK3623S, 70 Series, Triplex plunger pump features exclusive HT technology. Designed specifically for use in rollover car wash systems and other industrial plant systems where hot water is required.

**Max. Inlet Pressure: 125 PSI Max. Fluid Temperature: 185° F Inlet Port Thread: 1" NPT-F Discharge Port Thread: 1/2" NPT-F Shaft Diameter: 1.181 in./30 mm Pump Dimensions: 15.3" x 13.4" x 7.7" Max. Inlet Vacuum: 3 ft. water (2.6 in. Hg) Crankcase Oil Capacity: 64.2 oz. Use GP Series 100 Oil, (see page 57) Product Group: X**

	GPM	PSI	RPM	BORE	STROKE	HP	SHP WGHT
HTCK3623S*	21.0/25.0	1500/1300	1150/1350	1.4 in/36 mm	.9/23 mm	22.0	79.6 lbs.



See page 48 for further details

**HTCK4050S**

Emperor HTCK4050S, 71 Series, Triplex plunger pump features exclusive HT technology. Designed as a direct replacement for Cat's 3535 with the distinct advantage of featuring General Pump's patented HT technology. Ideal for use in rollover car washes and other industrial plant systems where hot water is required.

**Max. Inlet Pressure: 125 PSI Max. Fluid Temperature: 185° F Inlet Port Thread: 1-1/2" NPT-F Discharge Port Thread: 1" NPT-F Shaft Diameter: 1.575 in./40 mm Pump Dimensions: 20.7" x 14.5" x 9.9" Max. Inlet Vacuum: 3 ft. water (2.6 in. Hg) Crankcase Oil Capacity: 124.4 oz. Use GP Series 100 Oil, (see page 57) Product Group: X**

	GPM	PSI	RPM	BORE	STROKE	HP	SHP WGHT
HTCK4050S*	36.0	1500	800	1.6 in/40 mm	1.9/50 mm	38.0	157 lbs.

\*Also available in "L" left-hand version.

# INDUSTRIAL APPLICATIONS



## **Misting/Fogging**

- Evaporative cooling
- Insect control
- Bird control
- Odor control
- Fire suppression
- Tower cooling
- Power generation

## **Water jet technology**

- Coating removal
- Surface preparation
- Materials cutting/machining

## **Industrial process**

- Hydraulic ram/press operation
- Hydrostatic testing

## **Industrial cleaning**

- General cleaning
- Surface stripping
- Scale removal
- Barrel cleaning

## **Food processing**

- Poultry deboning
- Sanitation
- Wine making

## **Agricultural**

- Hydro-seeding
- Fertilizer injection

## **Boats and pleasure craft**

- Watermaking
- Washdown
- Boat hull cleaning

## **Water treatment**

- Reverse osmosis
- Desalination
- Water purification

## **Sewer maintenance**

- Sewer jetting
- Root cutting

## **Tank cleaning**

- Barrel reconditioning
- Wine making

# INDUSTRIAL POWER UNITS

**You need it, we can build it.  
Fully customized to fit your application.**

Electric, Gas, Diesel or Hydraulic Drive Options  
Dual, Stacked or Multiple  
Stationary or Portable

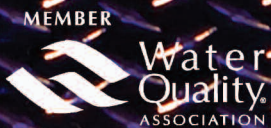
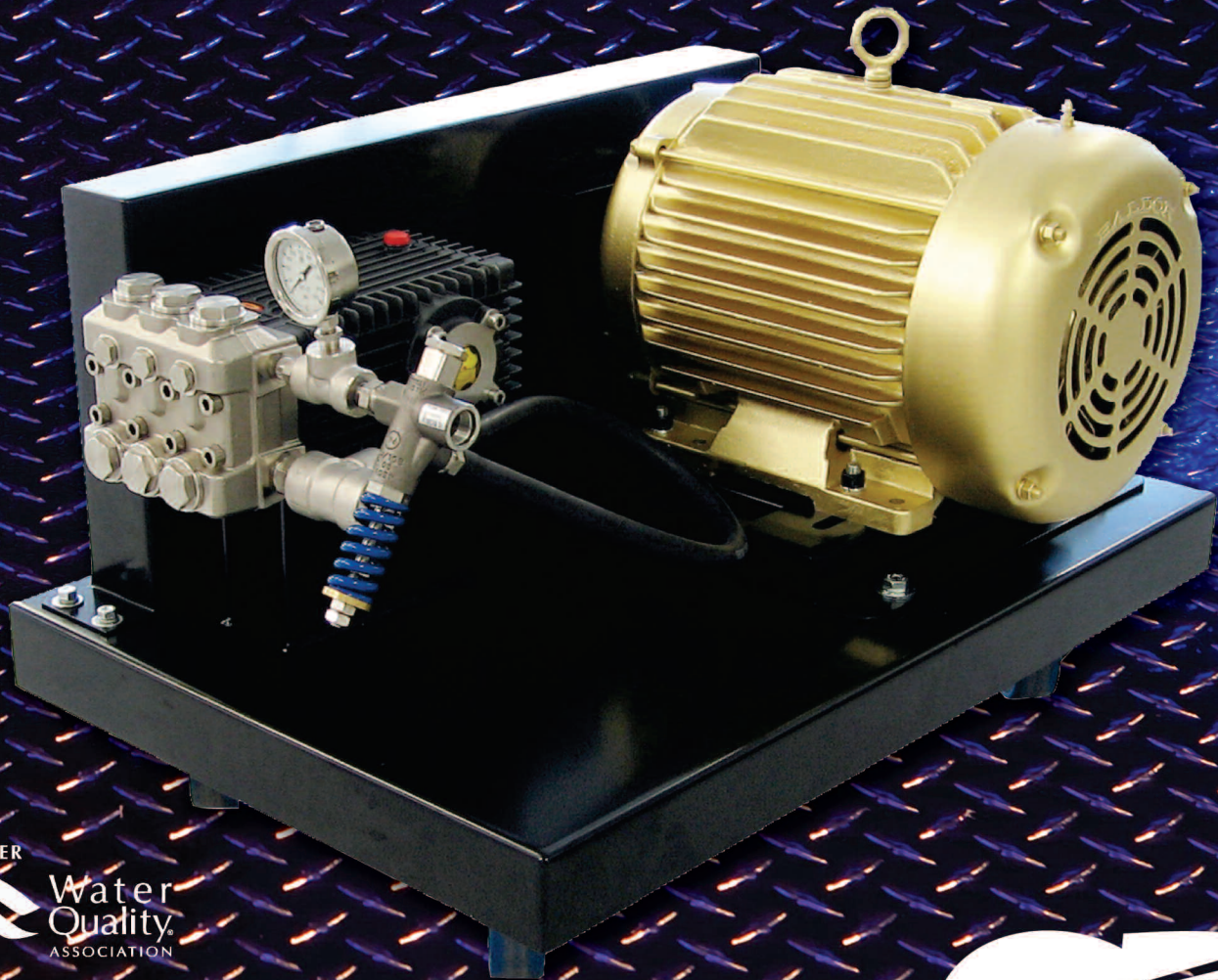

[www.generalspump.com](http://www.generalspump.com)



## FEATURES

- A "New Generation" Pump
- Triplex Plunger Pump, available in 5 flows
- Patent-pending, symmetrical power end design featuring top and bottom mounting holes allowing for easy left to right shaft conversion
- Low-high pressure packing design with integrated cooling system
- High volumetric efficiency suction/delivery valves featuring new spherical design of sealing areas
- Splash lubrication
- SAE-B hydraulic drive bell housing and flexible couplers available



## MATERIALS

- High resistance light alloy die cast aluminum crankcase
- 420 Stainless steel manifold, nickel treated
- Taper roller bearings
- Special antifriction, forged, light alloy connecting rods
- Forged alloy steel crankshaft, hardened, tempered and nitrided
- Cast iron piston guide, nickel treated
- Solid ceramic plungers
- Stainless steel valves
- Pumps are also available with 316 SS packing components. These models use prefix "KEN"

## COMMON SPECIFICATIONS

- Maximum Inlet Pressure: ..... 45 PSI
- Maximum Fluid Temperature: ..... \*140° F
- Inlet Port Thread: ..... 1" NPT-F
- Discharge Port Thread: ..... 1/2" NPT-F
- Shaft Diameter: ..... 1.181"/30 mm
- Stroke: ..... 0.9055"/23 mm
- Pump Dimensions: ..... 15.2" x 13.4" x 7.7"
- Crankcase Oil Capacity: ..... 67.63 oz. (2 liters)  
..... (use GP Series 220 Oil-see page 57)
- Shipping Weight: ..... 88 lbs./40 kg

\*Please consult technical guide or GP Sales Representative for Temperature/Inlet Pressure Information.

### Product Group: V

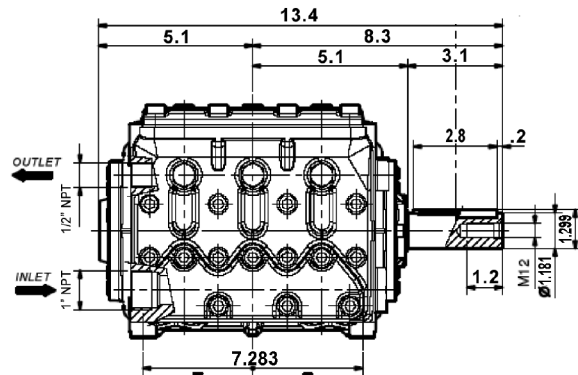
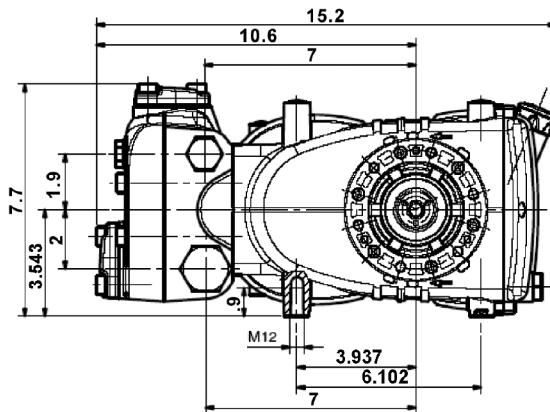

Note: All models come standard with crankshaft on right side (when facing manifold).

MODEL	GPM/LPM	PSI/BAR	RPM	BORE	HP
KE20A	8.3 GPM/31 LPM	4350 PSI/300 BAR	1450 RPM	.787 in./20 mm	25.0
KE22A	10.0 GPM/38 LPM	3625 PSI/250 BAR	1450 RPM	.866 in./22 mm	25.0
KE24A	11.9 GPM/45 LPM	3045 PSI/210 BAR	1450 RPM	.944 in./24 mm	25.0
KE28A	16.3 GPM/61 LPM	2175 PSI/150 BAR	1450 RPM	1.102 in./28 mm	24.0
KE30A	18.5 GPM/70 LPM	1885 PSI/130 BAR	1450 RPM	1.181 in./30 mm	24.0

Substitute prefix "KEN" for KE in above model numbers for models with 316 SS packing components. Above pumps also available with crankshaft on left side. To order, add an "L" to the end of the model number.





### FEATURES

- A "New Generation" Pump
- Triplex Plunger Pump, available in 4 flows
- Patent-pending, symmetrical power end design featuring top and bottom mounting holes allowing for easy left to right shaft conversion
- Low-high pressure packing design with integrated cooling system
- High volumetric efficiency suction/delivery valves featuring new spherical design of sealing areas
- Splash lubrication
- SAE-C hydraulic drive bell housing and flexible couplers available
- Available with external gear box (direct drive only), see page 40

### MATERIALS

- High resistance light alloy die cast crankcase
- 420 stainless steel manifold, nickel treated
- Taper roller bearings
- Special antifriction, forged, light alloy connecting rods
- Forged alloy steel crankshaft, hardened, tempered and nitrited
- Cast iron piston guide, nickel treated
- Solid ceramic plungers
- Stainless steel valves

### COMMON SPECIFICATIONS

- Maximum Inlet Pressure: ..... 45 PSI
- Maximum Fluid Temperature: ..... \*140° F
- Inlet Port Thread: ..... 1" NPT-F
- Discharge Port Thread: ..... 3/4" NPT-F
- Shaft Diameter: ..... 1.575"/40 mm
- Stroke: ..... 1.969"/50 mm
- Pump Dimensions: ..... 20" x 14.5" x 9.4"
- Crankcase Oil Capacity: ..... 128.5 oz. (3.8 liters)  
..... (use GP Series 220 Oil-see page 57)
- Shipping Weight: ..... 132 lbs./60 kg

### Product Group: V

\*Please consult technical guide or GP Sales Representative for Temperature/Inlet Pressure Information.

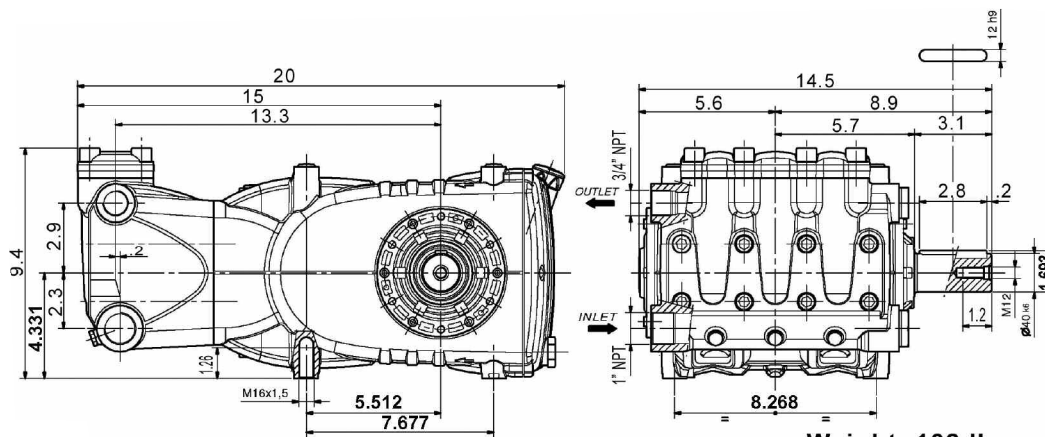

Weight: 132 lb.

Note: All models come standard with crankshaft on right side (when facing manifold), specify "L" when ordering left hand version.

MODEL	GPM/LPM	PSI/BAR	RPM	BORE	HP
HF18A	8.06 GPM/30 LPM	8700 PSI/600 BAR	800 RPM	.708 in./18 mm	48.0
HF18A	10.08 GPM/38 LPM	7250 PSI/500 BAR	1000 RPM	.708 in./18 mm	50.0
HF20A	12.4 GPM/47 LPM	5800 PSI/400 BAR	1000 RPM	.787 in./20 mm	48.0
HF22A	12.05 GPM/46 LPM	5800 PSI/400 BAR	800 RPM	.866 in./22 mm	48.0
HF22A	15.0 GPM/57 LPM	5075 PSI/350 BAR	1000 RPM	.866 in./22 mm	48.0
HF25A	19.6 GPM/74 LPM	4050 PSI/280 BAR	1000 RPM	.984 in./25 mm	53.0

Above pumps also available with crankshaft on left side. To order, add an "L" to the end of the model number.

## FEATURES

- A "New Generation" Pump
- Triplex Plunger Pump, available in 4 flows
- Patent-pending, symmetrical power end design featuring top and bottom mounting holes allowing for easy left to right shaft conversion
- Low-high pressure packing design with integrated cooling system
- High volumetric efficiency suction/delivery valves featuring new spherical design of sealing areas
- Splash lubrication
- SAE-C hydraulic drive bell housing flexible couplers available
- Available with external gear box (direct drive only), see page 40

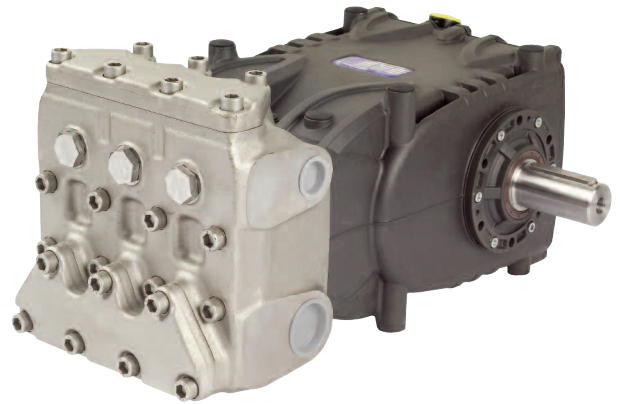

## MATERIALS

- High resistance light alloy die cast aluminum crankcase
- 420 stainless steel manifold, nickel treated
- Taper roller bearings
- Special antifriction, forged, light alloy connecting rods
- Forged alloy steel crankshaft, hardened, tempered and nitrited
- Cast iron piston guide, nickel treated
- Solid ceramic plungers
- Stainless steel valves
- Pumps are also available with 316 SS packing components. These models use prefix "KFN"

## COMMON SPECIFICATIONS

- Maximum Inlet Pressure: ..... 45 PSI
- Maximum Fluid Temperature: ..... \*140° F
- Inlet Port Thread: ..... 1-1/2" NPT-F
- Discharge Port Thread: ..... 1" NPT-F
- Shaft Diameter: ..... 1.575"/40 mm
- Stroke: ..... 1.969"/50 mm
- Pump Dimensions: ..... 20.7" x 14.5" x 9.9"
- Crankcase Oil Capacity: ..... 128.5 oz. (3.8 liters)  
..... (use GP Series 220 Oil-see page 57)
- Shipping Weight: ..... 150 lbs./68 kg

\*Please consult technical guide or GP Sales Representative for Temperature/Inlet Pressure Information.

## Product Group: V

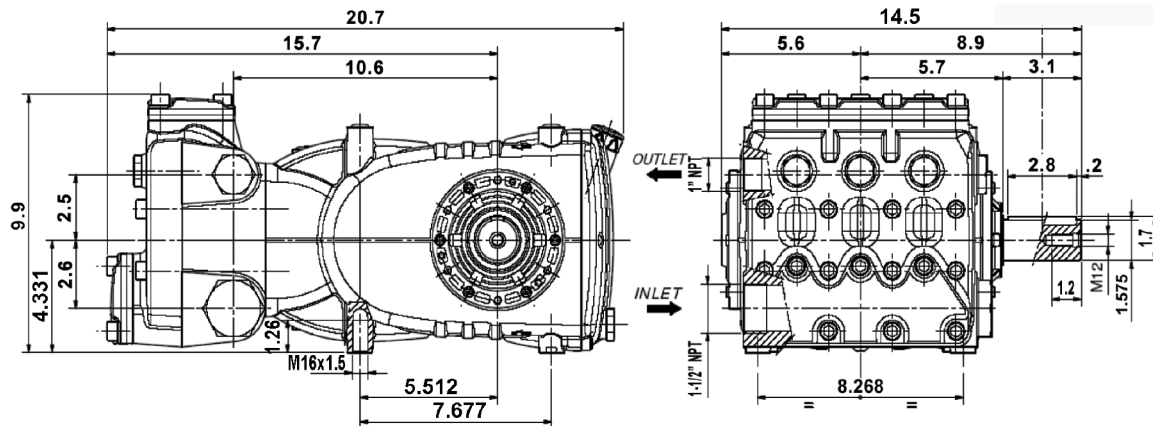

Note: All models come standard with crankshaft on right side (when facing manifold), specify "L" when ordering left hand version.

MODEL	GPM/LPM	PSI/BAR	RPM	BORE	HP
KF28A	24.5 GPM/93 LPM	3045 PSI/210 BAR	1000 RPM	1.102 in./28 mm	50.0
KF30A	28 GPM/106 LPM	2890 PSI/200 BAR	1000 RPM	1.181 in./30 mm	55.0
KF36A	32.2 GPM/122 LPM	2300 PSI/160 BAR	800 RPM	1.417 in./36 mm	50.0
KF36A	36.2 GPM/137 LPM	2050 PSI/140 BAR	900 RPM	1.417 in./36 mm	50.0
KF36A	40 GPM/153 LPM	1900 PSI/130 BAR	1000 RPM	1.417 in./36 mm	52.0
KF40A	45 GPM/170 LPM	1600 PSI/110 BAR	900 RPM	1.574 in./40 mm	49.0

Substitute prefix "KFN" for KF in above model numbers for models with 316 SS packing components. Above pumps also available with crankshaft on left side. To order, add an "L" to the end of the model number.

Please refer to pages 42-45 for fittings, safety devices and other accessories. Performances refer to theoretical delivery with 100% volumetric efficiency. Under normal operating conditions, pump volumetric efficiency is over 95%. Please contact our technical staff in case of continuous, heavy-duty, or special applications.

**NEW!**



### FEATURES

- High pressure “MUD” pump
- Specifically designed to pump mixtures of water, bentonite and/or polymers typical of mining and directional drilling applications
- Patent-pending, symmetrical power end design featuring top and bottom mounting holes allowing for easy left to right shaft conversion
- 17-4 stainless steel valves are guided to promote efficient delivery of fluids. Seating areas are treated with abrasion resistant material to extend life of wearing surfaces.
- Energized packings/seals are produced from high density polyethylene
- Splash lubrication
- Extended crosshead features open design and double oil seals to minimize unwanted collection of drilling fluids.
- Available in hydraulic version

### MATERIALS

- High resistance light alloy crankcase
- Stainless steel manifold, nickel treated
- Tapered roller rim bearings
- Special antifriction, light alloy connecting rods
- Forged alloy steel crankshaft, hardened, tempered and nitrited
- Cast iron piston guide, nickel treated
- Solid ceramic plungers, with ceramic coated Stainless Steel extension.
- Valve disks and seats 17/4 Stainless Steel.

### COMMON SPECIFICATIONS

- Maximum Inlet Pressure: ..... 45 PSI
- Maximum Fluid Temperature: ..... \*140° F
- Inlet Port Thread: ..... 1-1/4" NPT-F
- Discharge Port Thread: ..... 1" NPT-F
- Shaft Diameter: ..... 1.6"/40 mm
- Stroke: ..... 1.9"/50 mm
- Pump Dimensions: ..... 23.6" x 10" x 9.9"
- Crankcase Oil Capacity: ..... 124.4 oz. (3.68 liters)  
..... (use GP Series 220 Oil-see page 57)
- Shipping Weight: ..... 160 lbs./73 kg

**Product Group: V**

*\*Please consult technical guide or GP Sales Representative for Temperature/Inlet Pressure Information.*

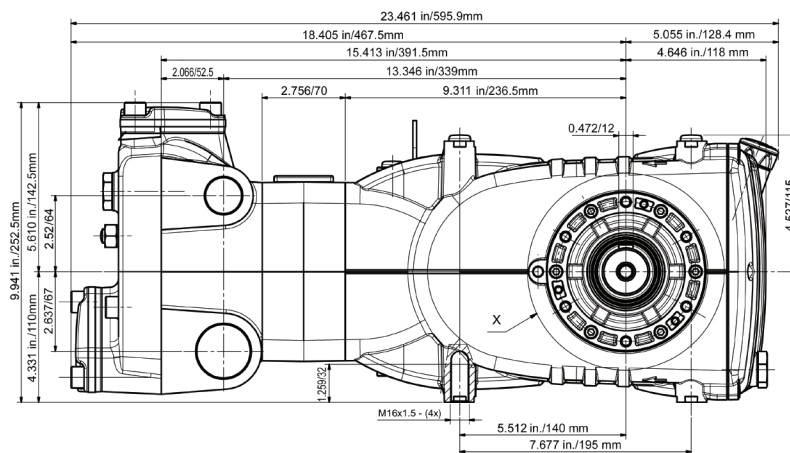

**Note: All models come standard with crankshaft on right side (when facing manifold).**

MODEL	GPM/LPM	PSI/BAR	RPM	BORE	STROKE	HP
KFM40A	30.0 GPM/114 LPM	1500 PSI/103 BAR	600 RPM	.1571 in./40 mm	1.9 in./50 mm	30.0

## FEATURES

- A "New Generation" Pump
- Triplex Plunger Pump, available in 4 flows
- Patent-pending, symmetrical power end design featuring top and bottom mounting holes allowing for easy left to right shaft conversion
- Low-high pressure packing design with integrated cooling system
- High volumetric efficiency suction/delivery valves featuring new spherical design of sealing areas
- Splash lubrication
- Available with external gear box in three ratios and positionable on left or right (direct drive only)
- SAE-C hydraulic drive bell housing and flexible couplers available

Available without gear box for belt driven and hydraulic drive applications

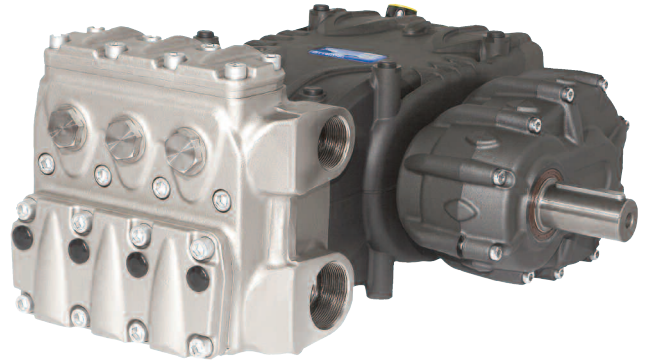

## MATERIALS

- High resistance die cast aluminum light alloy crankcase
- Spheroidal cast iron manifold, nickel treated
- Taper roller bearings
- Special antifriction light alloy connecting rods
- Forged alloy steel crankshaft, hardened, tempered and nitrited
- Cast iron piston guide, nickel treated
- Solid ceramic plungers
- Stainless steel valves

## COMMON SPECIFICATIONS

- Maximum Inlet Pressure: ..... 45 PSI
- Maximum Fluid Temperature: ..... \*140° F
- Inlet Port Thread: ..... 2" NPT-F
- Discharge Port Thread: ..... 1-1/2" NPT-F
- Shaft Diameter: ..... 1.575"/40 mm
- Stroke: ..... 1.969"/50 mm
- Pump Dimensions: ..... 23" x 19" x 11"
- Crankcase Oil Capacity, with gearbox: 162.3 oz. (4.8 liters)  
..... (use GP Series 220 Oil-see page 57)
- Shipping Weight: ..... 212 lbs./96 kg

## Product Group: V

\*Please consult technical guide or GP Sales Representative for Temperature/Inlet Pressure Information.

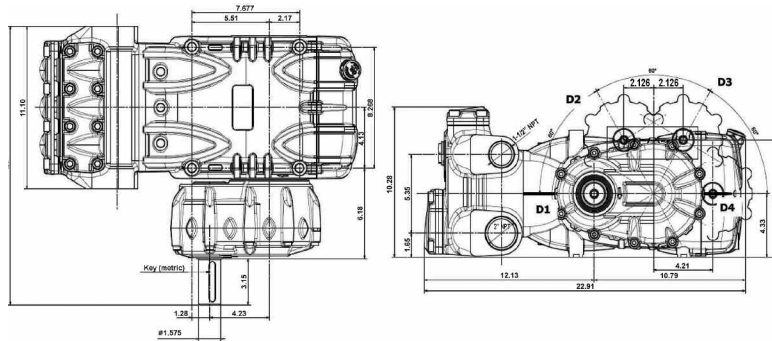

Note: All models come standard with crankshaft on right side (when facing manifold).

MODEL	GPM/LPM	PSI/BAR	RPM	BORE	EBHP
KS28SA	24.0 GPM/91 LPM	4000 PSI/276 BAR	1000 RPM	1.102 in./28 mm	67.0
KS28A	29.0 GPM/110 LPM	3625 PSI/250 BAR	1200 RPM	1.102 in./28 mm	72.0
KS32A	38.0 GPM/145 LPM	3000 PSI/200 BAR	1200 RPM	1.26 in./32 mm	78.0
KS36A	48.0 GPM/183 LPM	2320 PSI/160 BAR	1200 RPM	1.417 in./36 mm	76.0
KS40A	60.0 GPM/226 LPM	2000 PSI/138 BAR	1200 RPM	1.574 in./40 mm	82.0

## How to order/Examples of Part Numbers:

When ordering with gear box:



So the Part Number in the Above Example: **KS28A15R1**

(Model is KS28A, with an RPM of 1500, gear box positioned on right side of pump, in the first position.)

Please refer to pages 42-45 for fittings, safety devices and other accessories. Performances refer to theoretical delivery with 100% volumetric efficiency. Under normal operating conditions, pump volumetric efficiency is over 95%. Please contact our technical staff in case of continuous, heavy-duty, or special applications.

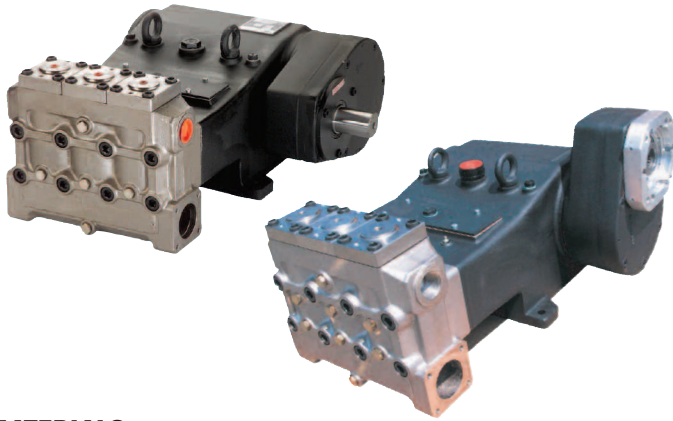

### FEATURES

- Triplex Plunger Pump, available in 5 flows
- Double pressure packings
- Vertically fitted suction/delivery valves
- Splash lubrication
- SAE-C, 4-bolt hydraulic drive available
- Available with or without external gear box in three ratios and positionable on left or right
- Gear ratios: 1500 RPM=2.037:1, 1800 RPM=2.417:1, 2200 RPM=3.04:1

### MATERIALS

- Pump body in cast iron
- Manifold made of spheroidal cast iron, nickel treated
- Self adjusting spherical roller bearings on crankshaft
- Forged steel connecting rods with antifriction bearings
- Crankshaft made of nitrided, hardened and tempered alloy steel
- Cast iron piston guide, nickel treated
- Ceramic coated plungers
- Stainless steel valves

### COMMON SPECIFICATIONS

- Maximum Inlet Pressure: ..... 45 PSI
- Maximum Fluid Temperature: ..... \*140° F
- Inlet Port Thread: ..... 2-1/2" NPT-F
- Discharge Port Thread: ..... 1-1/4" NPT-F
- Shaft Diameter: ..... 2.758"/70 mm
- Stroke: ..... 2.362"/60 mm
- Pump Dimensions: ..... 27.8" x 23.8" x 11.9"
- Crankcase Oil Capacity (w/Gear box): . 338 oz. (10 liters)  
..... (use GP Series 220 Oil-see page 57)
- Shipping Weight: ..... 570 lbs./no gear - 620 lbs. w/gear

### Product Group: V

\*Please consult technical guide or GP Sales Representative for Temperature/Inlet Pressure Information.

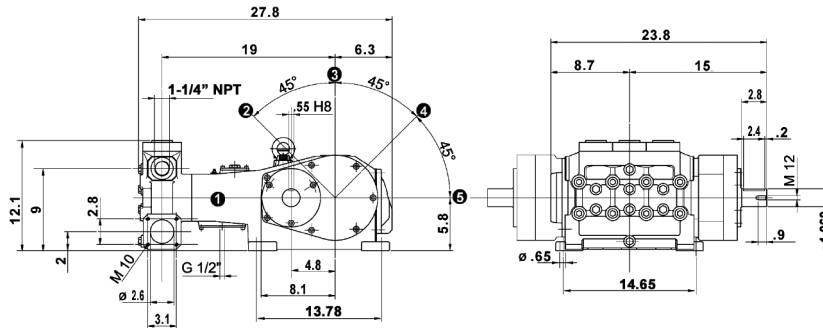

Note: All models come standard with crankshaft on right side (when facing manifold).

MODEL	GPM/LPM	PSI/BAR	RPM	BORE	SHAFT DIA.	EBHP
MSS36	35.9 GPM/136 LPM	4350 PSI/300 BAR	750 RPM	1.417 in./36 mm	2.758 in./70 mm	107.0
MSS36	35.4 GPM/134 LPM	4350 PSI/300 BAR	1500/1800	1.417 in./36 mm	1.969 in./50 mm	105.5
MSS40	44.4 GPM/168 LPM	3500 PSI/241 BAR	750 RPM	1.575 in./40 mm	2.758 in./70 mm	106.4
MSS40	43.9 GPM/166 LPM	3500 PSI/241 BAR	1500/1800	1.575 in./40 mm	1.969 in./50 mm	105.2
MSS45	56.3 GPM/213 LPM	2750 PSI/190 BAR	750 RPM	1.772 in./45 mm	2.758 in./70 mm	106.0
MSS45	55.5 GPM/210 LPM	2750 PSI/190 BAR	1500/1800	1.772 in./45 mm	1.969 in./50 mm	104.5
MSS50	69.5 GPM/263 LPM	2250 PSI/155 BAR	750 RPM	1.969 in./50 mm	2.758 in./70 mm	107.1
MSS50	68.7 GPM/260 LPM	2250 PSI/155 BAR	1500/1800	1.969 in./50 mm	1.969 in./50 mm	105.9
MSS55	84.0 GPM/317 LPM	1800 PSI/124 BAR	750 RPM	2.165 in./55 mm	2.758 in./70 mm	103.6
MSS55	83.0 GPM/314 LPM	1800 PSI/124 BAR	1500/1800	2.165 in./55 mm	1.969 in./50 mm	102.3

### How to order/Examples of Part Numbers:

When ordering with gear box:

Start with Model

RPM (ex.: 15=1500 RPM)

Gear Box Positioned on Left/Right

Add Gear Position (1-5)

MSS36

15

R

1

So the Part Number in the Above Example: **MSS3615R1**

(Model is MS36A, with an RPM of 1500, gear box positioned on right side of pump, in the first postion.)

# MK 40/45/50 SERIES

## FEATURES

- A "New Generation" Pump
- Triplex Plunger Pump, available in 3 flows
- Low-high pressure packing design with integrated cooling system
- High volumetric efficiency suction/delivery valves featuring new spherical design of sealing areas
- Splash lubrication
- Available with external gear box in 1500/1800 RPM, positionable on left or right
- SAE "D" hydraulic drive available
- Includes drain/priming valve kit
- Gear Ratios: 1500 RPM=2.65:1, 1800=3.29:1

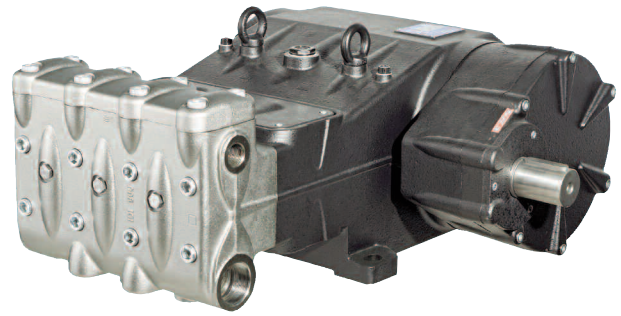

## MATERIALS

- Pump body in cast iron
- Manifold made of spheroidal cast iron, nickel treated
- Self adjusting spherical roller bearings on crankshaft
- Forged steel connecting rods with antifricition bearings
- Crankshaft made of nitrided, hardened and tempered alloy steel
- Cast iron piston guide, nickel treated
- Solid ceramic plungers
- Stainless steel valves

## COMMON SPECIFICATIONS

- Maximum Inlet Pressure: ..... 45 PSI
- Maximum Fluid Temperature: ..... \*140° F
- Inlet Port Thread: ..... 2" NPT
- Discharge Port Thread: ..... 1" NPT-F
- Shaft Diameter: ..... 2.165"/55 mm
- Stroke: ..... 2.835"/72 mm
- Pump Dimensions: ..... 32.64" x 29.38" x 14.25"
- Crankcase Oil Capacity: ..... 456.5 oz. (13.5 liters)  
..... (use GP Series 220 Oil-see page 57)
- Shipping Weight: ..... 833 lbs./378 kg

### Product Group: V

\*Please consult technical guide or GP Sales Representative for Temperature/Inlet Pressure Information.

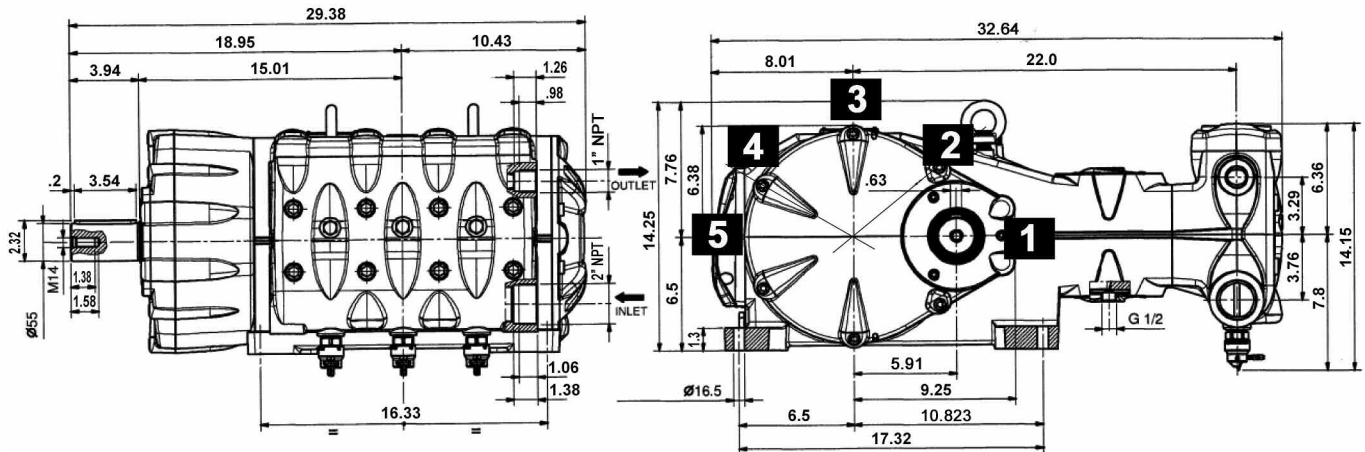

Note: All models come standard with crankshaft on right side (when facing manifold).

MODEL	GPM/LPM	PSI/BAR	RPM	BORE	EBHP
MK40A	40.0 GPM/151 LPM	5800 PSI/400 BAR	1500/1800 RPM	1.575 in./40 mm	159
MK45A	50.0 GPM/190 LPM	4350 PSI/300 BAR	1500/1800 RPM	1.722 in./45 mm	149
MK50A	62.0 GPM/235 LPM	3625 PSI/250 BAR	1500/1800 RPM	1.969 in./50 mm	154

How to order/Examples of Part Numbers:

When ordering with gear box:



So the Part Number in the Above Example: **MK40A15L1**

(Model is MK40A, with an RPM of 1500, gear box positioned on left side of pump, in the first position.)

Please refer to pages 42-45 for fittings, safety devices and other accessories. Performances refer to theoretical delivery with 100% volumetric efficiency. Under normal operating conditions, pump volumetric efficiency is over 95%. Please contact our technical staff in case of continuous, heavy-duty, or special applications.

# MK 55/60/65 SERIES

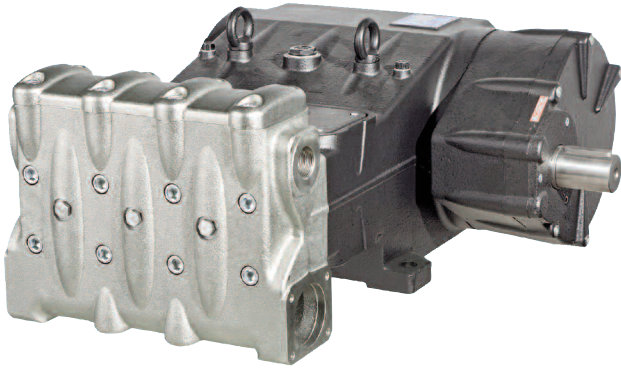

## FEATURES

- A "New Generation" Pump
- Triplex Plunger Pump, available in 3 flows
- Low-high pressure packing design with integrated cooling system
- High volumetric efficiency suction/delivery valves featuring new spherical design of sealing areas
- Splash lubrication
- Available with external gear box in 1500/1800 RPM, positionable on left or right
- SAE-D hydraulic drive available
- Includes drain/priming valve kit
- Gear ratios: 1500 RPM=2.65:1, 1800 RPM=3.29:1

## MATERIALS

- Pump body in cast iron
- Manifold made of spheroidal cast iron, nickel treated
- Self adjusting spherical roller bearings on crankshaft
- Forged steel connecting rods with antifriction bearings
- Crankshaft made of nitrided, hardened and tempered alloy steel
- Cast iron piston guide, nickel treated
- Solid ceramic plungers
- Stainless steel valves

## COMMON SPECIFICATIONS

- Maximum Inlet Pressure: ..... 45 PSI
- Maximum Fluid Temperature: ..... \*140° F
- Inlet Port Thread: ..... 3" NPT-Flange
- Discharge Port Thread: ..... 1-1/4" NPT-F
- Shaft Diameter: ..... 2.165"/55 mm
- Stroke: ..... 2.835"/72 mm
- Pump Dimensions: ..... 33.11" x 29.38" x 14.25"
- Crankcase Oil Capacity: ..... 456.5 oz. (13.5 liters)  
..... (use GP Series 220 Oil-see page 57)
- Shipping Weight: ..... 862 lbs./391 kg

## Product Group: V

\*Please consult technical guide or GP Sales Representative for Temperature/Inlet Pressure Information.

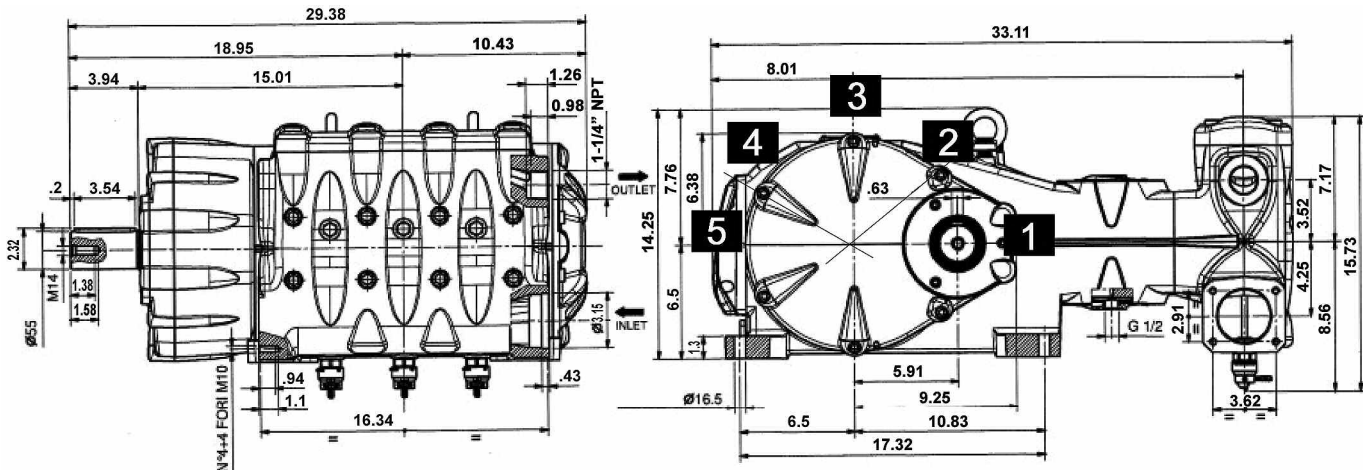

Note: All models come standard with crankshaft on right side (when facing manifold).

MODEL	GPM/LPM	PSI/BAR	RPM	BORE	EBHP
MK55A	75.0 GPM/283 LPM	2900 PSI/200 BAR	1500/1800 RPM	2.165 in./55 mm	149
MK60A	90.0 GPM/340 LPM	2500 PSI/170 BAR	1500/1800 RPM	2.362 in./60 mm	152
MK65A	107.0 GPM/406 LPM	2175 PSI/150 BAR	1500/1800 RPM	2.559 in./65 mm	160

How to order/Examples of Part Numbers:

When ordering with gear box:



So the Part Number in the Above Example: **MK55A15L1**

(Model is MK55A, with an RPM of 1500, gear box positioned on left side of pump, in the first position.)

# MKS 40/45/50 SERIES

## FEATURES

- A "New Generation" Pump
- Triplex Plunger Pump, available in 3 flows
- Low-high pressure packing design with integrated cooling system
- High volumetric efficiency suction/delivery valves featuring new spherical design of sealing areas
- Splash lubrication
- Available with external gear box in 1500/1800 RPM, positionable on left or right
- SAE-D hydraulic drive available
- Includes drain/priming valve kit
- Gear Ratios: 1500 RPM=2.23:1, 1800 RPM=2.65:1

## MATERIALS

- Pump body in cast iron
- Manifold made of spheroidal cast iron, nickel treated
- Self adjusting spherical roller bearings on crankshaft
- Forged steel connecting rods with antifriction bearings
- Crankshaft made of nitrided, hardened and tempered alloy steel
- Cast iron piston guide, nickel treated
- Solid ceramic plungers
- Stainless steel valves

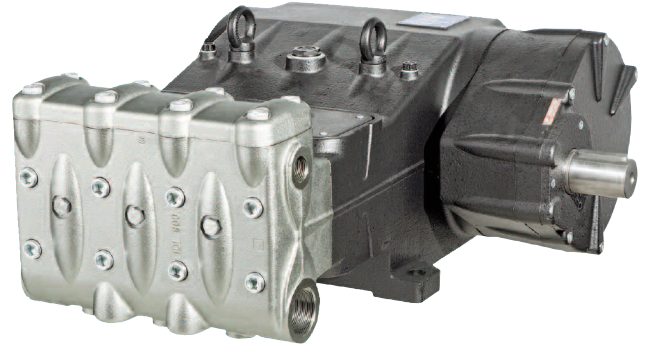

## COMMON SPECIFICATIONS

- Maximum Inlet Pressure: ..... 45 PSI
- Maximum Fluid Temperature: ..... \*140° F
- Inlet Port Thread: ..... 2" NPT
- Discharge Port Thread: ..... 1" NPT-F
- Shaft Diameter: ..... 2.165"/55 mm
- Stroke: ..... 2.835"/72 mm
- Pump Dimensions: ..... 32.64" x 29.38" x 14.25"
- Crankcase Oil Capacity: ..... 456.5 oz. (13.5 liters)  
..... (use GP Series 220 Oil-see page 57)
- Shipping Weight: ..... 833 lbs./378 kg

## Product Group: V

\*Please consult technical guide or GP Sales Representative for Temperature/Inlet Pressure Information.

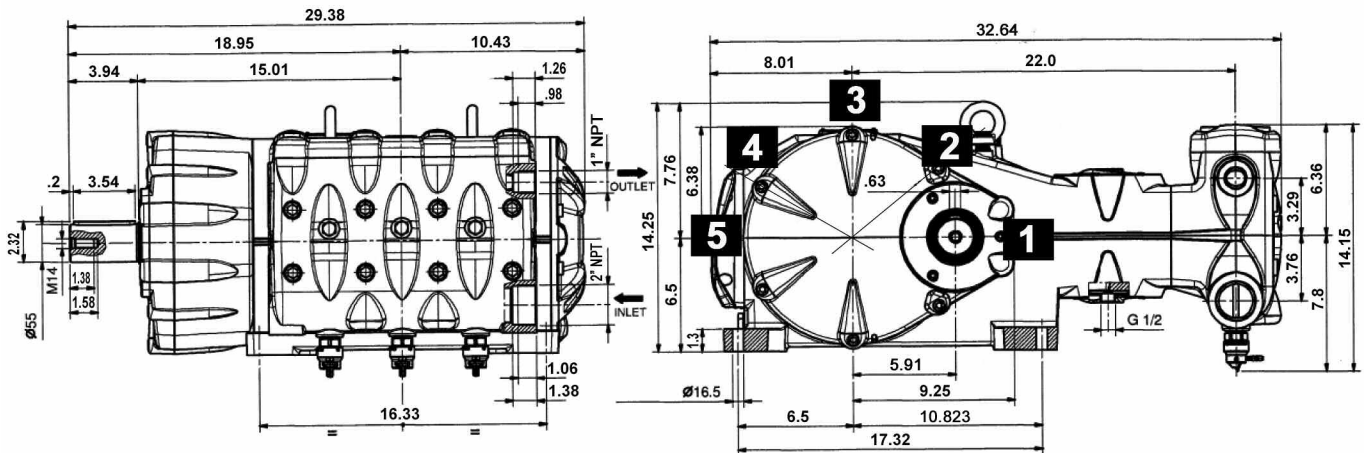

Note: All models come standard with crankshaft on right side (when facing manifold).

MODEL	GPM/LPM	PSI/BAR	RPM	BORE	EBHP
MKS40A	48.7 GPM/184 LPM	5800 PSI/400 BAR	1500/1800 RPM	1.575 in./40 mm	194
MKS45A	61.6 GPM/233 LPM	4350 PSI/300 BAR	1500/1800 RPM	1.722 in./45 mm	184
MKS50A	76.0 GPM/288 LPM	3600 PSI/250 BAR	1500/1800 RPM	1.969 in./50 mm	187

How to order/Examples of Part Numbers:

When ordering with gear box:



So the Part Number in the Above Example: **MKS40A15L1**

(Model is MKS40A, with an RPM of 1500, gear box positioned on left side of pump, in the first position.)

Please refer to pages 42-45 for fittings, safety devices and other accessories. Performances refer to theoretical delivery with 100% volumetric efficiency. Under normal operating conditions, pump volumetric efficiency is over 95%. Please contact our technical staff in case of continuous, heavy-duty, or special applications.



# MKS 55/60/65 SERIES

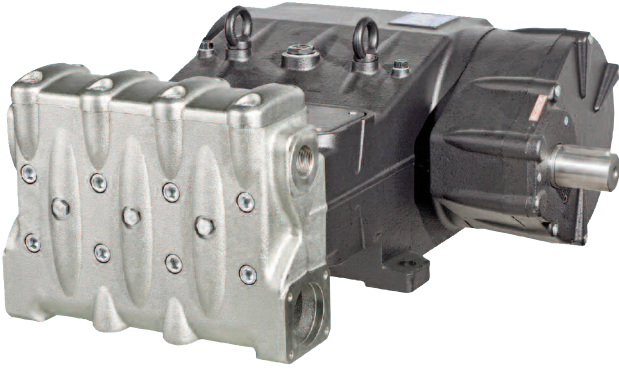

## FEATURES

- A "New Generation" Pump
- Triplex Plunger Pump, available in 3 flows
- Low-high pressure packing design with integrated cooling system
- High volumetric efficiency suction/delivery valves featuring new spherical design of sealing areas
- Splash lubrication
- Available with external gear box in 1500/1800 RPM, positionable on left or right
- SAE "D" hydraulic drive available
- Includes drain/priming valve kit
- Gear Ratios: 1500 RPM=2.23:1, 1800 RPM=2.65:1

## MATERIALS

- Pump body in cast iron
- Manifold made of spheroidal cast iron, nickel treated
- Self adjusting spherical roller bearings on crankshaft
- Forged steel connecting rods with antifriction bearings
- Crankshaft made of nitrided, hardened and tempered alloy steel
- Cast iron piston guide, nickel treated
- Solid ceramic plungers
- Stainless steel valves

## COMMON SPECIFICATIONS

- Maximum Inlet Pressure: ..... 45 PSI
- Maximum Fluid Temperature: ..... \*140° F
- Inlet Port Thread: ..... 3" NPT-Flange
- Discharge Port Thread: ..... 1-1/4" NPT-F
- Shaft Diameter: ..... 2.165"/55 mm
- Stroke: ..... 2.835"/72 mm
- Pump Dimensions: ..... 33.11" x 29.38" x 14.25"
- Crankcase Oil Capacity: ..... 456.5 oz. (13.5 liters)  
..... (use GP Series 220 Oil-see page 57)
- Shipping Weight: ..... 862 lbs./391 kg

## Product Group: V

\*Please consult technical guide or GP Sales Representative for Temperature/Inlet Pressure Information.

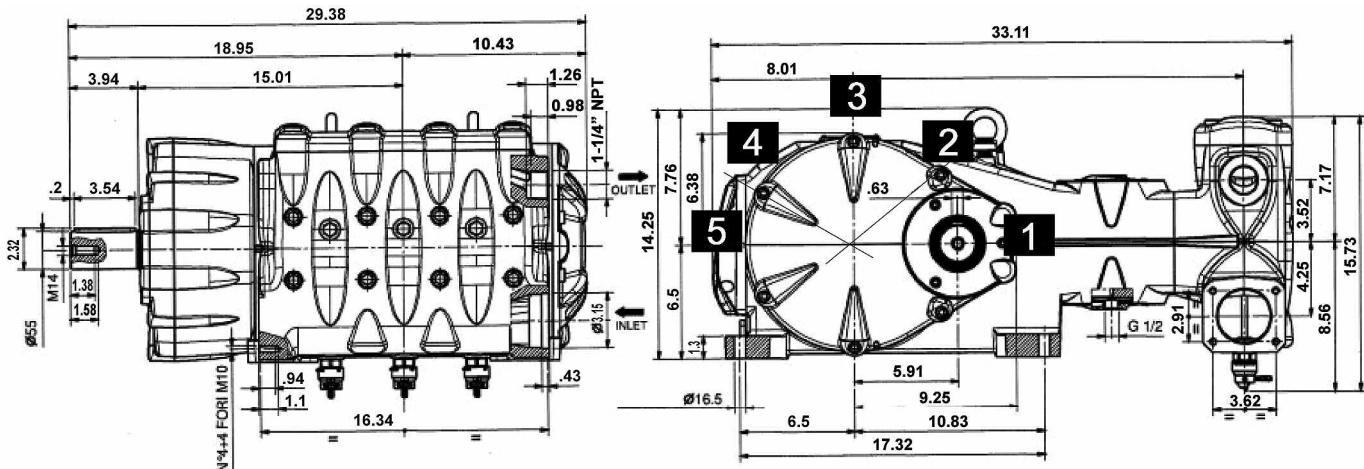

Note: All models come standard with crankshaft on right side (when facing manifold).

MODEL	GPM/LPM	PSI/BAR	RPM	BORE	EBHP
MKS55A	92.0 GPM/348 LPM	2950 PSI/203 BAR	1500/1800 RPM	2.165 in./55 mm	185
MKS60A	109 GPM/414 LPM	2500 PSI/170 BAR	1500/1800 RPM	2.362 in./60 mm	187
MKS65A	128 GPM/486 LPM	2100 PSI/150 BAR	1500/1800 RPM	2.559 in./65 mm	183

## How to order/Examples of Part Numbers:

When ordering with gear box:



So the Part Number in the Above Example: **MKS55A15L1**

(Model is MKS55A, with an RPM of 1500, gear box positioned on left side of pump, in the first position.)

# LK SERIES

## FEATURES

- Triplex Plunger Pump, available in 6 flows
- Drive shaft with double projection
- Incorporated gear box available in three ratios, 1500 RPM=2.950:1, 1750 RPM=3.158:1 and 1900=3.389:1
- Double pressure packings
- Vertically fitted suction/delivery valves
- Splash lubrication
- Optional drain/priming valve kit

## MATERIALS

- Pump body in cast iron
- Manifold made of spheroidal cast iron, nickel treated
- Self adjusting spherical roller bearings on crankshaft
- Forged connecting rods with antifriction bearings
- Crankshaft made of nitrided, hardened and tempered alloy steel
- Cast iron plunger guides, nickel nitrided
- Valves made in stainless steel and bronze

**NEW!**

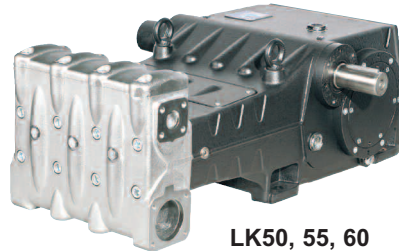

LK50, 55, 60



LK36, 40, 45

## COMMON SPECIFICATIONS

- Maximum Inlet Pressure: ..... 45 PSI
- Maximum Fluid Temperature: ..... \*140° F
- Inlet Port Thread: (LK36, 40, 45) ..... 2" NPT-F  
(LK50, 55, 60) ..... 3" NPT-F Flange
- Discharge Port Thread: (LK36, 40, 45) ..... 1" NPT-F  
(LK55, 55, 60) 1-1/4" NPT-F Flange
- Shaft Diameter: ..... 1.969"/50 mm
- Stroke: ..... 3.546"/90 mm
- Pump Dimensions: ..... 36.4" x 26.4" x 13.7"
- Crankcase Oil Capacity: ..... 473.5 oz/14 liters)  
..... (use GP Series 220 Oil-see page 57)
- Shipping Weight: ..... .829 lbs./376 kg

## Product Group: V

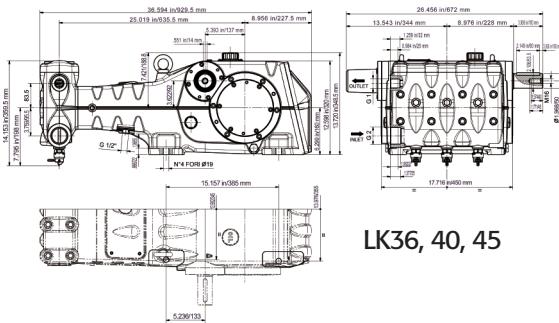

LK36, 40, 45

\*Please consult technical guide or GP Sales Representative for Temperature/Inlet Pressure Information.

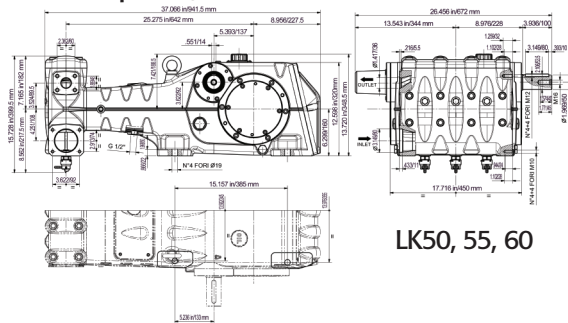

LK50, 55, 60

MODEL	GPM/LPM	PSI/BAR	RPM	BORE	EBHP
LK3615	37.0 GPM/140 LPM	5800 PSI/400 BAR	1500 RPM	1.417 in./36 mm	147
LK3617	40.1 GPM/152 LPM	5800 PSI/400 BAR	1750 RPM	1.417 in./36 mm	159
LK4015	45.7 GPM/173 LPM	5075 PSI/350 BAR	1500 RPM	1.575 in./40 mm	159
LK4017	49.6 GPM/188 LPM	5075 PSI/350 BAR	1750 RPM	1.575 in./40 mm	172
LK4515	57.6 GPM/218 LPM	4060 PSI/280 BAR	1500 RPM	1.772 in./45 mm	160
LK4517	62.8 GPM/238 LPM	4060 PSI/280 BAR	1750 RPM	1.772 in./45 mm	175
LK5015	71.0 GPM/269 LPM	3335 PSI/230 BAR	1500 RPM	1.969 in./50 mm	162
LK5017	77.6 GPM/294 LPM	3335 PSI/230 BAR	1750 RPM	1.969 in./50 mm	178
LK5515	86.1 GPM/326 LPM	2755 PSI/190 BAR	1500 RPM	2.165 in./55 mm	163
LK5517	93.7 GPM/355 LPM	2755 PSI/190 BAR	1750 RPM	2.165 in./55 mm	177
LK6015	102.4 GPM/388 LPM	2320 PSI/160 BAR	1500 RPM	2.362 in./60 mm	163
LK6017	111.7 GPM/423 LPM	2320 PSI/160 BAR	1750 RPM	2.362 in./60 mm	178

How to order/Examples of Part Numbers:

Start with Model

LK40

RPM (ex.: 15=1500 RPM)

15

So the Part Number in the Above Example: **LK4015** (Model is LH40, with an RPM of 1500.)

Please refer to pages 42-45 for fittings, safety devices and other accessories. Performances refer to theoretical delivery with 100% volumetric efficiency. Under normal operating conditions, pump volumetric efficiency is over 95%. Please contact our technical staff in case of continuous, heavy-duty, or special applications.

## FEATURES

- A "New Generation" Pump
- Triplex Plunger Pump, available in 2 flows
- Patent pending, symmetrical power end design featuring top and bottom mounting holes for easy left to right shaft conversion
- Pressure packing design integrated cooling system
- Horizontally fitted in-line valves
- Splash lubrication
- SAE-C hydraulic drive available bell housing and flexible couplers available
- Available with external gear box (direct drive only), see page 40



## MATERIALS

- High resistance die-cast light alloy crankcase
- Stainless steel manifold, nickel treated
- Taper roller bearings
- Special antifriction, forged, light alloy connecting rods
- Forged alloy steel crankshaft, hardened, tempered and nitrited
- Cast iron piston guide, nickel treated
- Solid ceramic plungers
- Stainless steel valves

## COMMON SPECIFICATIONS

- Maximum Inlet Pressure: ..... 100 PSI
- Minimum Inlet Pressure: ..... 45 PSI
- Maximum Fluid Temperature: ..... \*86° F
- Inlet Port Thread: ..... 3/4" BSP-F
- Discharge Port Thread: ..... 1/2" BSP-F Flange
- Shaft Diameter: ..... 1.575"/40 mm
- Stroke: ..... 1.969"/50 mm
- Pump Dimensions: ..... 24" x 15" x 9.0"
- Crankcase Oil Capacity: ..... 128.5 oz. (3.8 liters)  
..... (use GP Series 220 Oil-see page 57)
- Shipping Weight: ..... 150 lbs./68 kg

### Product Group: V

\*Please consult technical guide or GP Sales Representative for Temperature/Inlet Pressure Information.

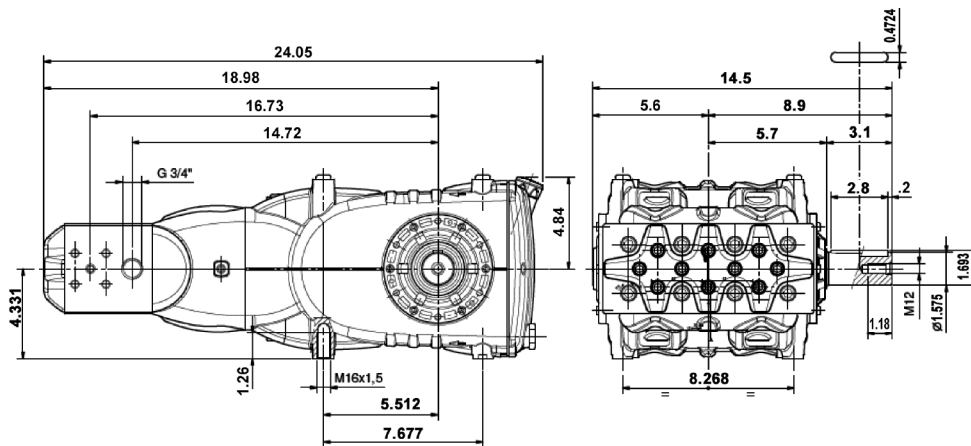

Note: All models come standard with crankshaft on right side (when facing manifold) specify "L" when ordering left hand version.

MODEL	GPM/LPM	PSI/BAR	RPM	BORE	EBHP
VF12	3.4 GPM/12.5 LPM	21750 PSI/1500 BAR	750 RPM	.472 in./12 mm	50.3
	4.0 GPM/15 LPM	17400 PSI/1200 BAR	1000 RPM	.472 in./12 mm	48.0
VF14	4.6 GPM/17 LPM	15950 PSI/1100 BAR	750 RPM	.551 in./14 mm	50.2
	6.1 GPM/23 LPM	11600 PSI/800 BAR	1000 RPM	.551 in./14 mm	48.7

How to order/Examples of Part Numbers:

When ordering with gear box:

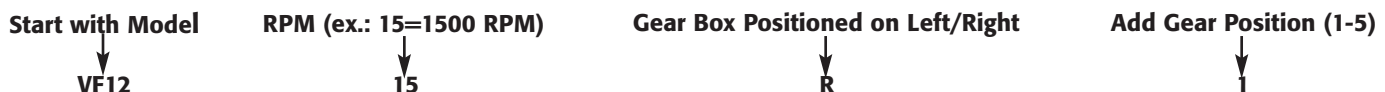

So the Part Number in the Above Example: **VF1215RI**

(Model is VF12, with an RPM of 1500, gear box positioned on left side of pump, in the first position.)

Please refer to pages 42-45 for fittings, safety devices and other accessories. Performances refer to theoretical delivery with 100% volumetric efficiency. Under normal operating conditions, pump volumetric efficiency is over 95%. Please contact our technical staff in case of continuous, heavy-duty, or special applications.

# VK SERIES

## FEATURES

- A "New Generation" Pump
- Triplex Plunger Pump, available in 2 flows
- Low-high pressure packing design with integrated cooling system
- High volumetric efficiency suction/delivery valves featuring new spherical design of sealing areas
- Splash lubrication
- Available with external gear box in 1500/1800/2200 RPM, positionable on left or right
- SAE-C hydraulic drive available
- Available with external gear box (direct drive only), see page 40

**NEW!**



## MATERIALS

- High resistance die-cast light alloy crankcase
- Stainless steel manifold, nickel treated
- Taper roller bearings
- Special antifriction, forged, light alloy connecting rods
- Forged alloy steel crankshaft, hardened, tempered and nitrided
- Cast iron piston guide, nickel treated
- Solid ceramic plungers
- Stainless steel valves

## COMMON SPECIFICATIONS

- Maximum Inlet Pressure: ..... 45 PSI
- Maximum Fluid Temperature: ..... \*140° F
- Inlet Port Thread: ..... 3/4" BSP-F
- Discharge Port Thread: ..... 1/2" BSP-F Flange
- Shaft Diameter: ..... 1.575"/40 mm
- Stroke: ..... 1.969"/50 mm
- Pump Dimensions: ..... .25.39" x 14.44" x 15.11"
- Crankcase Oil Capacity: ..... 162.3 oz. (4.8 liters)  
..... (use GP Series 220 Oil-see page 57)
- Shipping Weight: ..... 212 lbs./96 kg

## Product Group: V

\*Please consult technical guide or GP Sales Representative for Temperature/Inlet Pressure Information.

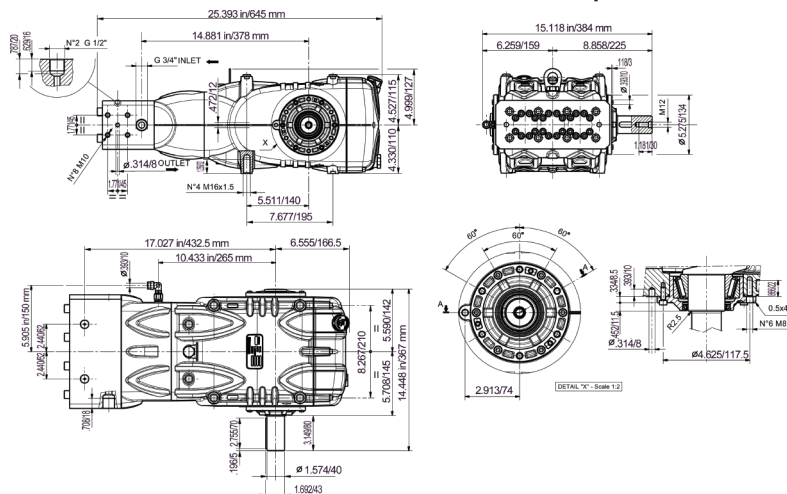

Note: All models come standard with crankshaft on right side (when facing manifold).

MODEL	GPM/LPM	PSI/BAR	RPM	BORE	EBHP
VK12	5.4 GPM/20.4 LPM	21750 PSI/1500 BAR	1200 RPM	.472 in./12 mm	79
VK14	7.4 GPM/28 LPM	15590 PSI/1075 BAR	1200 RPM	.551 in./14 mm	79

## How to order/Examples of Part Numbers:

When ordering with gear box:



So the Part Number in the Above Example: **VK1215L1**

(Model is VK12, with an RPM of 1500, gear box positioned on left side of pump, in the first position.)

Please refer to pages 42-45 for fittings, safety devices and other accessories. Performances refer to theoretical delivery with 100% volumetric efficiency. Under normal operating conditions, pump volumetric efficiency is over 95%. Please contact our technical staff in case of continuous, heavy-duty, or special applications.



## FEATURES

- Triplex Plunger Pump, available in 5 flows
  - Double pressure packings
  - Pressure packing integrated cooling system
  - Horizontally fitted in-line valves
  - Splash lubrication
  - Available with external gear box available (1500, 1800 & 2200 RPM) and positionable on left or right
  - SAE-C, 4-bolt hydraulic drive available
- Solid shaft only for belt-driven applications*

## MATERIALS

- High Resistance Stainless Steel Manifold
- Solid Ceramic Plungers
- Forged Steel Connecting Rods
- Stainless Steel Valves
- Tempered Steel Alloy Crankshaft
- Cast Iron Crankcase
- Double Rim Roller Bearings
- Proprietary Seal Technology

## COMMON SPECIFICATIONS

- Maximum Inlet Pressure: ..... 75 PSI
- Minimum Inlet Pressure: ..... 45 PSI
- Maximum Fluid Temperature: ..... \*85° F
- Inlet Port Thread: ..... 1-1/2" G
- Discharge Port Thread: ..... 1/2" G Flange
- Shaft Diameter: ..... 1.969"/50 mm
- Stroke: ..... 2.362"/60 mm
- Pump Dimensions: ..... 33.6" x 23.8" x 12.45"
- Crankcase Oil Capacity (w/gear box): . 338 oz. (10 liters)  
..... (use GP Series 220 Oil-see page 57)
- Shipping Weight: ..... 618 lbs./280 kg

### Product Group: V

\*Please consult technical guide or GP Sales Representative for additional fitting needs.

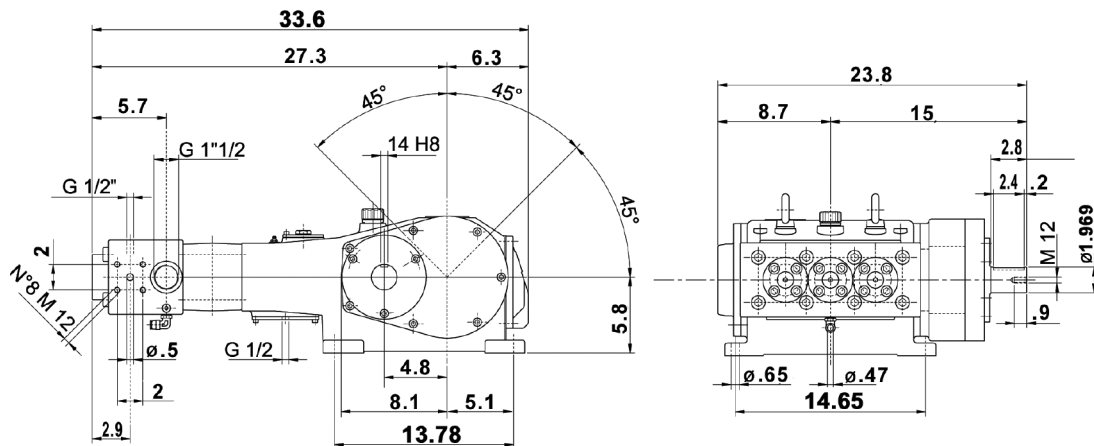

Note: All models come standard with crankshaft on right side (when facing manifold), specify "L" when ordering left hand version.

MODEL	GPM/LPM	PSI/BAR	RPM	BORE	EBHP
VS16	7.1 GPM/27 LPM	21750 PSI/1500 BAR	1500 RPM	.945 in./16 mm	105.6
VS18	9.0 GPM/34 LPM	17400 PSI/1200 BAR	1500 RPM	.709 in./18 mm	107.3
VS20	11.1 GPM/42 LPM	13050 PSI/900 BAR	1500 RPM	.787 in./20 mm	99.2
VS22	13.2 GPM/50 LPM	10800 PSI/750 BAR	1500 RPM	.868 in./22 mm	99.6
VS24	15.8 GPM/60 LPM	8700 PSI/600 BAR	1500 RPM	.945 in./24 mm	94.2

### How to order/Examples of Part Numbers:

When ordering with gear box:



So the Part Number in the Above Example: **VS1615R1**

(Model is VS16, with an RPM of 1500, gear box positioned on right side of pump, in the first position.)

# SK SERIES

## FEATURES

- Triplex Plunger Pump, available in 6 flows
- Double pressure packings
- Pressure packing integrated cooling system
- Horizontally fitted in-line valves
- Splash lubrication
- Hydraulic drive available
- Incorporated gear box available in two ratios  
1500 RPM=2.950:1 and 1900 RPM=3.389:1

**NEW!**



## MATERIALS

- High Resistance Stainless Steel Manifold
- Solid Ceramic Plungers
- Forged Steel Connecting Rods
- Stainless Steel Valves
- Tempered Steel Alloy Crankshaft
- Cast Iron Crankcase
- Double Rim Roller Bearings
- Proprietary Seal Technology

## COMMON SPECIFICATIONS

- Maximum Inlet Pressure: ..... 100 PSI
- Minimum Inlet Pressure: ..... 75 PSI
- Maximum Fluid Temperature: ..... \*86° F
- Inlet Port Thread: ..... 1-1/2" BSP-F
- Discharge Port Thread: ..... 14 mm Flange
- Shaft Diameter: ..... 1.969"/50 mm
- Stroke: ..... 3.546"/90 mm
- Pump Dimensions: ..... 42" x 26.4" x 13.7"
- Crankcase Oil Capacity: ..... 473.4 oz. (14 liters)  
..... (use GP Series 220 Oil-see page 57)
- Shipping Weight: ..... 840 lbs./381 kg

### Product Group: V

\*Please consult technical guide or GP Sales Representative for additional fitting needs.

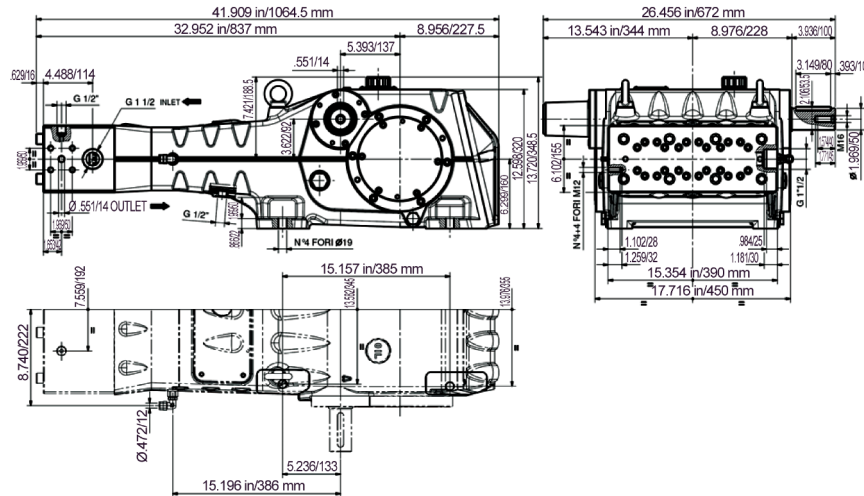

**Note: All models come standard with crankshaft on right side (when facing manifold).**

MODEL	GPM/LPM	PSI/BAR	RPM	BORE	EBHP
SK2015	11.4 GPM/43 LPM	21750 PSI/1500 BAR	1500 RPM	.787 in./20 mm	170
SK2017	11.6 GPM/44 LPM	21750 PSI/1500 BAR	1750 RPM	.787 in./20 mm	173
SK2215	13.7 GPM/52 LPM	18850 PSI/1300 BAR	1500 RPM	.866 in./22mm	177
SK2217	14.0 GPM/53 LPM	18850 PSI/1300 BAR	1750 RPM	.866 in./22mm	181
SK2415	16.4 GPM/62 LPM	15950 PSI/1100 BAR	1500 RPM	.945 in./24 mm	179
SK2417	16.6 GPM/63 LPM	15950 PSI/1100 BAR	1750 RPM	.945 in./24 mm	181
SK2615	19.3 GPM/73 LPM	13050 PSI/900 BAR	1500 RPM	1.024 in./26 mm	173
SK2617	19.5 GPM/74 LPM	13050 PSI/900 BAR	1750 RPM	1.024 in./26 mm	174
SK2815	22.2 GPM/84 LPM	11600 PSI/800 BAR	1500 RPM	1.102 in./28 mm	176
SK2817	22.7 GPM/86 LPM	11600 PSI/800 BAR	1750 RPM	1.102 in./28 mm	180
SK3015	25.3 GPM/97 LPM	10150 PSI/700 BAR	1500 RPM	1.181 in./30 mm	176
SK3017	25.9 GPM/98 LPM	10150 PSI/700 BAR	1750 RPM	1.181 in./30 mm	180

Please refer to pages 42-45 for fittings, safety devices and other accessories. Performances refer to theoretical delivery with 100% volumetric efficiency. Under normal operating conditions, pump volumetric efficiency is over 95%. Please contact our technical staff in case of continuous, heavy-duty, or special applications.

# AGGRESSIVE ENVIRONMENT PUMPS WM SERIES

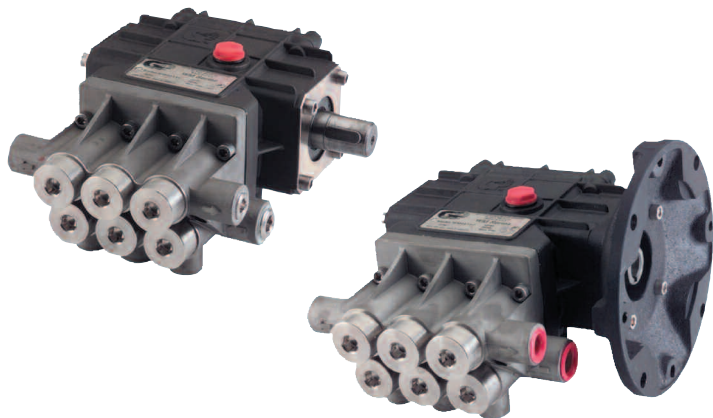

## FEATURES

- 316 stainless steel fluid end for superior corrosion protection
- Solid ceramic plungers with advanced surface finish assure durability and longevity
- Compact design offers solutions to space limitations
- Parallel inlet and outlet valve design for efficiency and easy maintenance
- Innovative wear resistant high and low pressure seals
- Available in left-hand configuration

## MATERIALS

- 316 Stainless Steel Manifold and Wetted Parts
- Solid Ceramic Plungers
- Anodized Crankcase
- 300 Series Stainless Steel Fasteners
- Buna-N Seals, Also Available in EPDM

## COMMON SPECIFICATIONS

- Maximum Inlet Pressure: ..... 50 PSI
- Maximum Discharge Pressure: ..... 1500 PSI
- Maximum Fluid Temperature: ..... 140° F
- RPM: ..... 1750 RPM
- Discharge Port Thread: ..... 3/8" NPT-F
- Inlet Port Thread: .. 1/2" NPT-F / 3/8-19 NPT-F (WM0515C)
- Maximum Inlet Vacuum: ..... -5 PSI
- Pump Dimensions: ..... 9" x 7.5" x 6.0"
- Crankcase Oil Capacity: ..... 12.0 oz. (.35 liters)  
..... (use GP Series 100 Oil-see page 57)
- Shipping Weight: ..... 13.5 lbs./6.12 kg

## Product Group: V

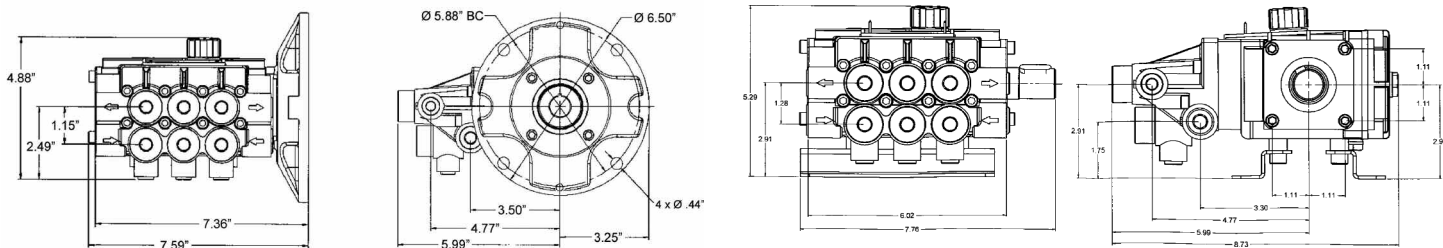

Note: All models come standard with crankshaft on right side (when facing manifold).

MODEL	GPM/LPM	PSI/BAR	BORE	STROKE	SHAFT
WM0515C	0.5 GPM/2 LPM	1500 PSI/103 BAR	.787 in./20 mm	.063 in./1.6 mm	5/8" Hollow
WM0815C	0.8 GPM/3 LPM	1500 PSI/103 BAR	.787 in./20 mm	.099 in./2.5 mm	5/8" Hollow
WM1015C	1.0 GPM/4 LPM	1500 PSI/103 BAR	.787 in./20 mm	.122 in./3.1 mm	5/8" Hollow
WM1615C	1.6 GPM/6 LPM	1500 PSI/103 BAR	.787 in./20 mm	.189 in./4.8 mm	5/8" Hollow
WM2315C	2.3 GPM/9 LPM	1500 PSI/103 BAR	.787 in./20 mm	.295 in./7.5 mm	5/8" Hollow
WM3015C	3.0 GPM/11 LPM	1500 PSI/103 BAR	.787 in./20 mm	.370 in./9.4 mm	5/8" Hollow
WM3615C	3.6 GPM/14 LPM	1500 PSI/103 BAR	.787 in./20 mm	.413 in./10.5 mm	5/8" Hollow
WM4215C	4.2 GPM/16 LPM	1500 PSI/103 BAR	.787 in./20 mm	.492 in./12.5 mm	5/8" Hollow
WM4215S	4.2 GPM/16 LPM	1500 PSI/103 BAR	.787 in./20 mm	.492 in./12.5 mm	24 mm Solid
WM4215C6	4.2 GPM/16 LPM	1500 PSI/103 BAR	.787 in./20 mm	.492 in./12.5 mm	3/4" Hollow

Above pumps also available with crankshaft on left side. To order, add an "L" to the end of the model number.

Also available with EPDM, to order add "E" to the end of the model number.

Available with motor attached.

# TX SERIES 63 AGGRESSIVE ENVIRONMENT PUMPS

## FEATURES

- Triplex Plunger Pump
- 316 Stainless Steel manifold for maximum corrosion resistance
- Energized special pressure packings
- 316 Stainless Steel inlet and outlet valves
- Solid ceramic plungers
- Ball bearings on both sides
- Patent-pending "high tech" low and high pressure seals

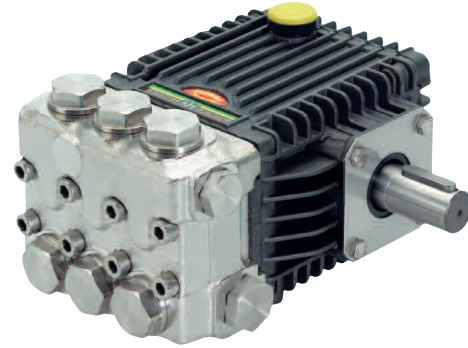

## MATERIALS

- 316 Stainless Steel manifold
- 316 Stainless Steel Valve cap
- PA11 valve guide
- 316 Stainless Steel valve spring
- 316 Stainless Steel valve seat
- Solid ceramic plungers
- 316 Stainless Steel valves

## COMMON SPECIFICATIONS

- Maximum Inlet Pressure: ..... 115 PSI
- Maximum Fluid Temperature (18 mm): ..... \*185° F
- Maximum Fluid Temperature (15 mm): ..... \*140° F
- Inlet Port Thread: ..... 1/2"-14 BSP-F
- Discharge Port Thread: ..... 3/8"-19 BSP-F
- Shaft Diameter: ..... .9449"/24 mm
- Pump Dimensions (no rails): ..... 8.4" x 8.3" x 4.8"
- Crankcase Oil Capacity: ..... 14.0 oz. (.41 liters)  
..... (use GP Series 100 Oil-see page 57)
- Shipping Weight: ..... 22.3 lbs./10 kg

## Product Group: V

\*Please consult technical guide or GP Sales Representative for Temperature/Inlet Pressure Information.

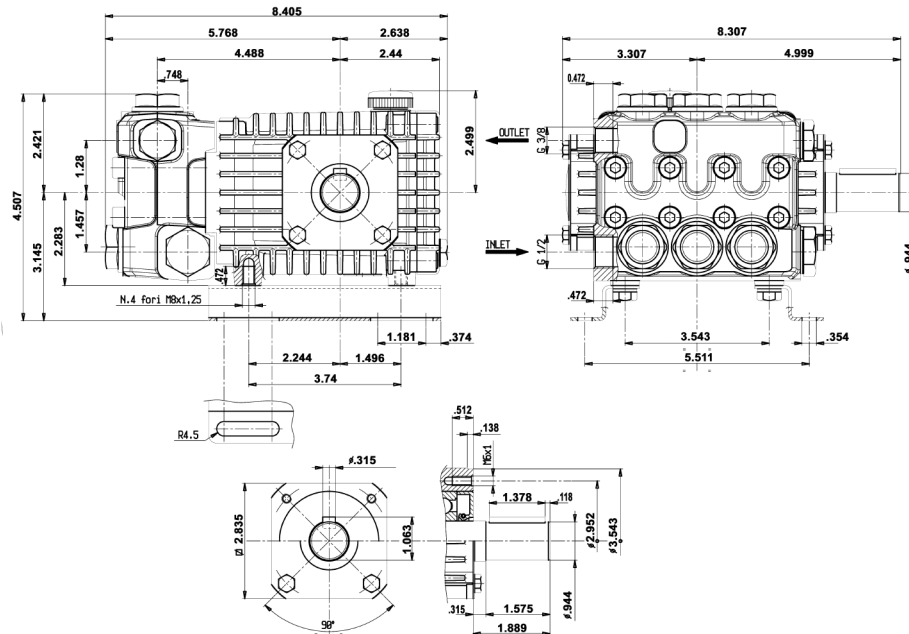

Note: All models come standard with crankshaft on right side (when facing manifold), specify "L" when ordering left hand version.

MODEL	GPM/LPM	PSI/BAR	RPM	BORE	STROKE	EBHP
TX1510S17SS	2.1 GPM/8 LPM	2200 PSI/152 BAR	1750 RPM	.591 in./15 mm	.394 in./10 mm	3.2
TX1512S17SS	2.6 GPM/10 LPM	2200 PSI/152 BAR	1750 RPM	.591 in./15 mm	.472 in./12 mm	4.0
TX1810S17SS	3.1 GPM/12 LPM	2000 PSI/138 BAR	1750 RPM	.709 in./18 mm	.394 in./10 mm	4.2
TX1812S17SS	3.8 GPM/14 LPM	2000 PSI/138 BAR	1750 RPM	.709 in./18 mm	.472 in./12 mm	5.2

Please refer to pages 42-45 for fittings, safety devices and other accessories. Performances refer to theoretical delivery with 100% volumetric efficiency. Under normal operating conditions, pump volumetric efficiency is over 95%. Please contact our technical staff in case of continuous, heavy-duty, or special applications.



# AGGRESSIVE ENVIRONMENT PUMPS T SERIES 47



## FEATURES

- Triplex Plunger Pump
- 316 Stainless Steel manifold for maximum corrosion resistance
- The preferred pump frame in the industry
- Solid ceramic plungers with continuously lubricated packings
- Over-sized connecting rods for maximum life
- Patent-pending "high tech" low and high pressure seals

## MATERIALS

- 316 Stainless Steel manifold
- 316 Stainless Steel valve cap
- PA11 valve guide
- 316 Stainless Steel valve spring
- 316 Stainless Steel valve seat
- Solid ceramic plungers
- 316 Stainless Steel valves

## COMMON SPECIFICATIONS

- Maximum Inlet Pressure: ..... 115 PSI
- Maximum Fluid Temperature (22 mm): ..... \*185° F
- Maximum Fluid Temperature (20 mm): ..... \*140° F
- Inlet Port Thread: ..... 1/2"-14 BSP-F
- Discharge Port Thread: ..... 3/8"-19 BSP-F
- Shaft Diameter: ..... .9449"/24 mm
- Pump Dimensions (no rails): ..... 12.4" x 9.2" x 5.7"
- Crankcase Oil Capacity: ..... 40.6 oz. (1.2 liters)  
..... (use GP Series 100 Oil-see page 57)
- Shipping Weight: ..... 31 lbs./14 kg

## Product Group: V

\*Please consult technical guide or GP Sales Representative for Temperature/Inlet Pressure Information.

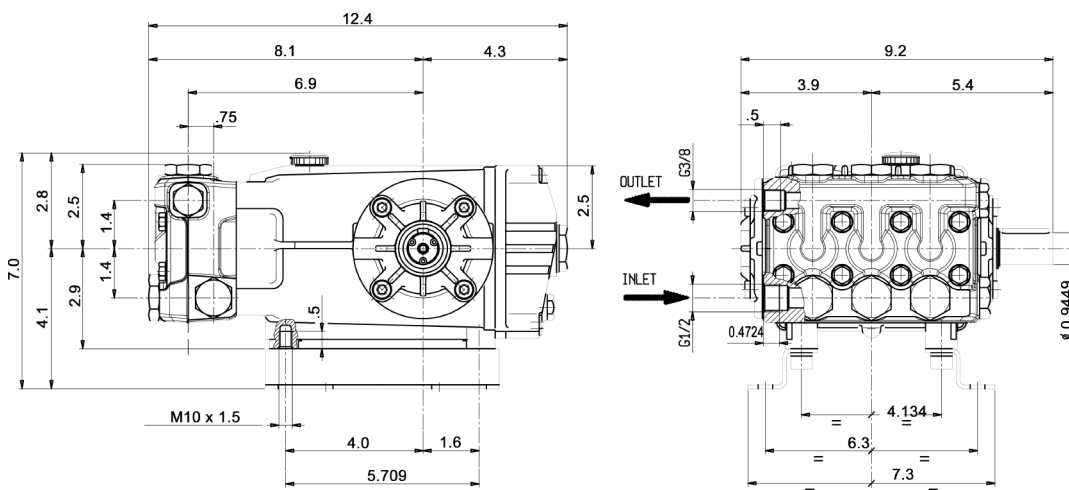

Note: All models come standard with crankshaft on right side (when facing manifold).

MODEL	GPM/LPM	PSI/BAR	RPM	BORE	STROKE	EBHP
TS2012SS	4.0 GPM/15 LPM	2200 PSI/152 BAR	1450 RPM	.787 in./20 mm	.472 in./12 mm	6.0
TS2012SS	4.75 GPM/18 LPM	2200 PSI/152 BAR	1750 RPM	.787 in./20 mm	.472 in./12 mm	7.2
TS2212SS	4.75 GPM/18 LPM	2200 PSI/152 BAR	1450 RPM	.866 in./22 mm	.472 in./12 mm	7.2
TS2016SS	5.55 GPM/21 LPM	2200 PSI/152 BAR	1450 RPM	.787 in./20 mm	.630 in./16 mm	8.4
TS2212SS	5.55 GPM/21 LPM	2200 PSI/152 BAR	1750 RPM	.866 in./22 mm	.472 in./12 mm	8.4

# TSF SERIES 66 AGGRESSIVE ENVIRONMENT PUMPS

## FEATURES

- Triplex Plunger Pump
- New ceramic plunger design improves thermal shock resistance
- 316 Stainless Steel wetted parts
- 316 Stainless Steel forged manifold
- Stainless Steel inlet/outlet valve plugs with improved hydrostatic performance
- Fully anodized crankcase
- Patent-pending "high tech" low and high pressure seals



## MATERIALS

- 316 Stainless Steel manifold
- 316 Stainless Steel Valve cap
- PA11 valve guide
- 316 Stainless Steel valve spring
- 316 Stainless Steel valve seat
- Solid ceramic plunger
- 316 Stainless Steel valves

## COMMON SPECIFICATIONS

- Maximum Inlet Pressure: ..... 115 PSI
- Maximum Fluid Temperature: ..... \*185° F
- Inlet Port Thread: ..... 3/4"-14 BSP-F
- Discharge Port Thread: ..... 3/8"-19 BSP-F
- Shaft Diameter: ..... 0.9449"/24 mm
- Stroke: ..... 0.8268"/21 mm
- Pump Dimensions (no rails): ..... 13.4" x 9.83" x 6.28"
- Crankcase Oil Capacity: ..... 40.6 oz. (1.2 liters)  
..... (use GP Series 100 Oil-see page 57)
- Shipping Weight: ..... 42 lbs./19 kg

## Product Group: V

\*Please consult technical guide or GP Sales Representative for Temperature/Inlet Pressure Information.

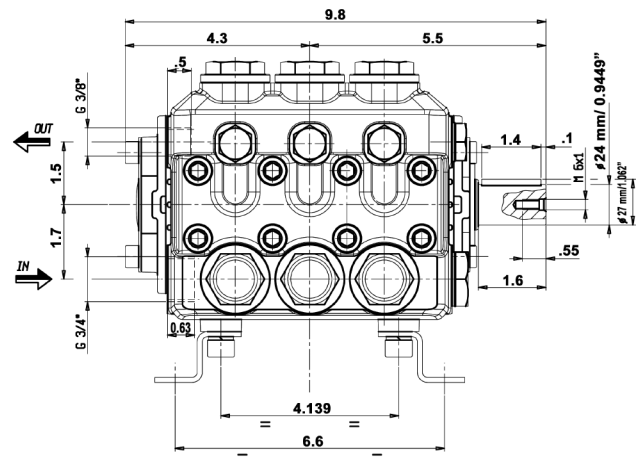
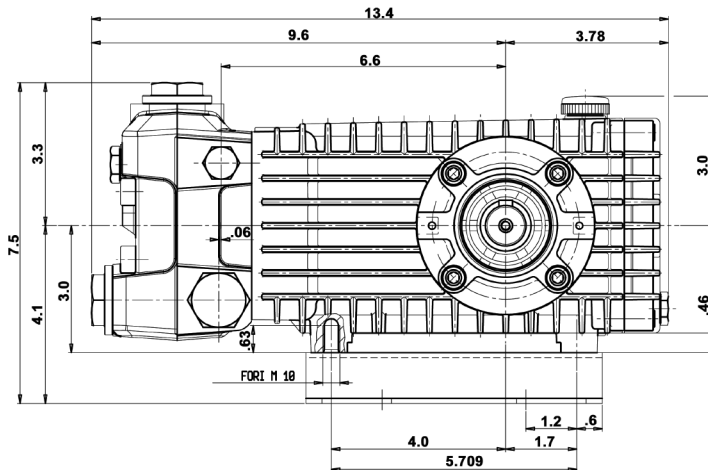

Note: All models come standard with crankshaft on right side (when facing manifold), specify "L" when ordering left hand version.

MODEL	GPM/LPM	PSI/BAR	RPM	BORE	EBHP
TSF2021SS	8.5 GPM/32 LPM	2200 PSI/152 BAR	1750 RPM	.787 in./20 mm	21
TSF2221SS	10.2 GPM/39 LPM	2200 PSI/152 BAR	1750 RPM	.866 in./22 mm	21
TSF2421SS	12.0 GPM/45 LPM	2200 PSI/152 BAR	1750 RPM	.945 in./24 mm	20.5

# AGGRESSIVE ENVIRONMENT PUMPS KEZ SERIES

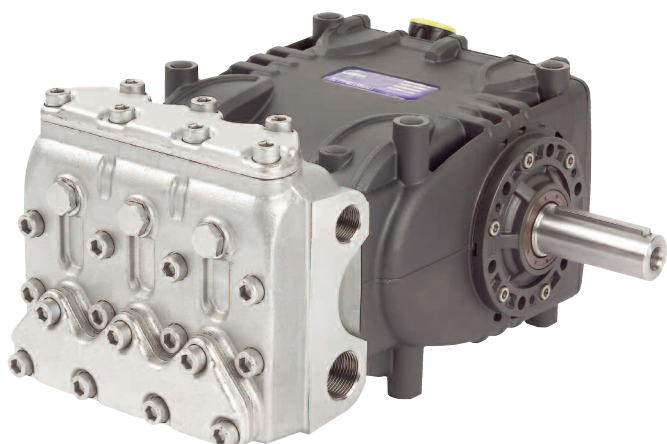

## FEATURES

- High Pressure Triplex Plunger Pump
- Patent pending, symmetrical power end design featuring top and bottom mounting holes allowing for easy left to right shaft conversion
- Low-high pressure packing design with integrated cooling system
- High volumetric efficiency suction/delivery valves featuring new spherical design of sealing areas
- Splash lubrication
- New high performance aluminum alloy connecting rods and a floating wrist pin enable extra load at half the weight. This reduces vibrations and off center loads on the bearing for longer life and quieter operation
- Patent-pending "high tech" low and high pressure seals

## MATERIALS

- Die-cast aluminum crankcase
- 316 Stainless steel manifold
- Taper roller bearings
- Special antifriction light alloy, forged, connecting rods
- Forged alloy steel crankshaft, hardened, tempered and nitrided
- Cast iron piston guide, nickel-treated
- Solid ceramic plungers
- 316 Stainless Steel valves

## COMMON SPECIFICATIONS

- Maximum Inlet Pressure: ..... 45 PSI
- Minimum Inlet Pressure: ..... 5 PSI
- Maximum Fluid Temperature: ..... \*140° F
- Inlet Port Thread: ..... 1" NPT-F
- Discharge Port Thread: ..... 1/2" NPT-F
- Shaft Diameter: ..... 1.181"/30 mm
- Stroke: ..... 0.9055"/23 mm
- Pump Dimensions: ..... 15.1" x 13.4" x 7.7"
- Crankcase Oil Capacity: ..... 67.63 oz. (2 liters)  
..... (use GP Series 220 Oil-see page 57)
- Shipping Weight: ..... 88 lbs./40 kg

## Product Group: V

\*Please consult technical guide or GP Sales Representative for Temperature/Inlet Pressure Information.

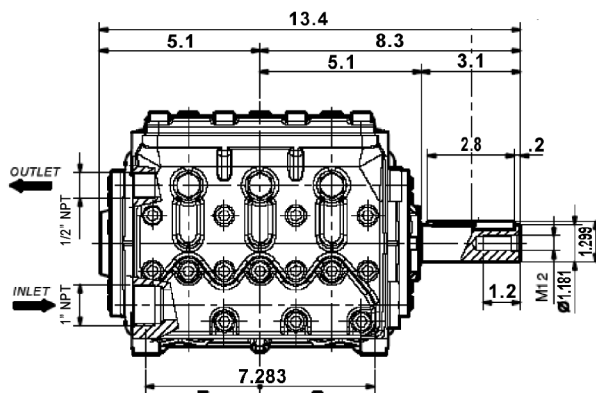
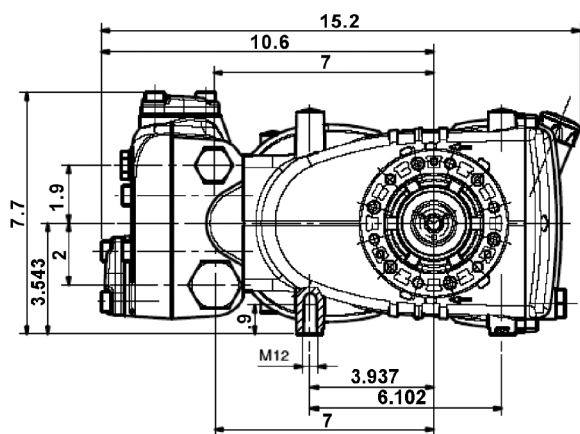

Note: All models come standard with crankshaft on right side (when facing manifold). Specify "L" when ordering left-hand version.

MODEL	GPM/LPM	PSI/BAR	RPM	BORE	EBHP
KEZ20A	8.0 GPM/31 LPM	3000 PSI/207 BAR	1450 RPM	.787 in./20 mm	17
KEZ22A	10.0 GPM/38 LPM	3000 PSI/207 BAR	1450 RPM	.866 in./22 mm	21
KEZ24A	11.9 GPM/45 LPM	3000 PSI/207 BAR	1450 RPM	.944 in./24 mm	25
KEZ28A	16.3 GPM/61 LPM	2170 PSI/150 BAR	1450 RPM	1.102 in./28 mm	25
KEZ30A	18.5 GPM/70 LPM	1880 PSI/130 BAR	1450 RPM	1.181 in./30 mm	25
KEZ36A	24.0 GPM/91 LPM	1450 PSI/100 BAR	1300 RPM	1.417 in./36 mm	25

# KFZ SERIES AGGRESSIVE ENVIRONMENT PUMPS

## FEATURES

- High Pressure Triplex Plunger Pump
- Patent pending, symmetrical power end design featuring top and bottom mounting holes allowing for easy left to right shaft conversion
- Low-high pressure packing design with integrated cooling system
- High volumetric efficiency suction/delivery valves featuring new spherical design of sealing areas
- Splash lubrication
- New high performance aluminum alloy connecting rods and a floating wrist pin enable extra load at half the weight
- SAE-C hydraulic drive available
- Available with external gearbox
- Patent-pending "high tech" low and high pressure seals  
Solid shaft only for belt-driven applications

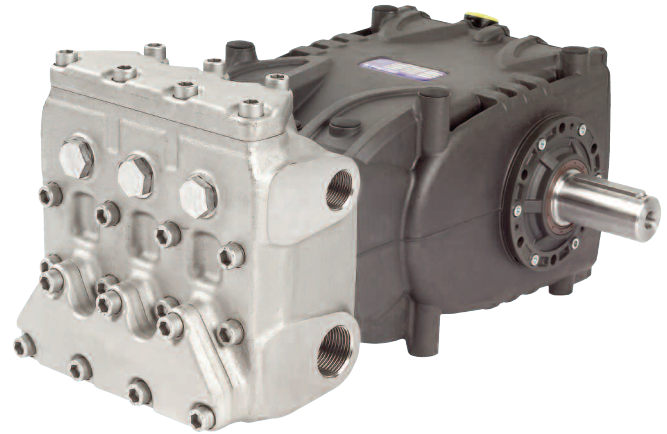

## MATERIALS

- High resistance light alloy crankcase
- 316 Stainless steel manifold
- Taper roller bearings
- Special antifriction light alloy, forged, connecting rods
- Forged alloy steel crankshaft, hardened, tempered and nitrided
- Cast iron piston guide, nickel-treated
- Solid ceramic plungers
- 316 Stainless Steel valves

## COMMON SPECIFICATIONS

- Maximum Inlet Pressure: ..... 45 PSI
- Maximum Fluid Temperature: ..... \*140° F
- Inlet Port Thread: ..... 1-1/2" NPT-F
- Discharge Port Thread: ..... 1" NPT-F
- Shaft Diameter: ..... 1.575"/40 mm
- Stroke: ..... 1.969"/50 mm
- Pump Dimensions: ..... 20.7" x 14.5" x 9.9"
- Crankcase Oil Capacity: ..... 128.5 oz. (3.8 liters)  
..... (use GP Series 220 Oil-see page 57)
- Shipping Weight: ..... 150 lbs./68 kg

### Product Group: V

\*Please consult technical guide or GP Sales Representative for Temperature/Inlet Pressure Information.

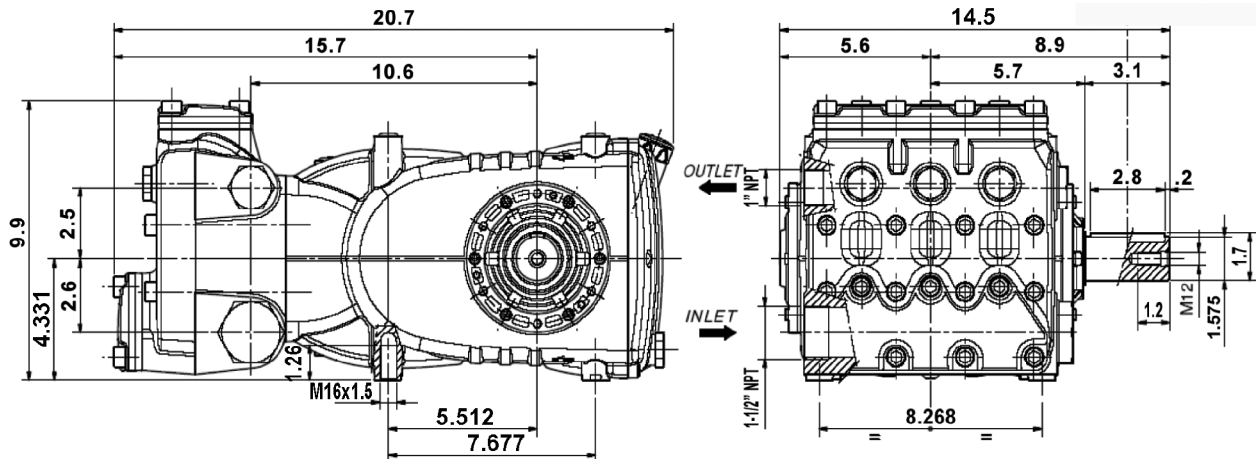

Note: All models come standard with crankshaft on right side (when facing manifold), specify "L" when ordering left hand version.

MODEL	GPM/LPM	PSI/BAR	RPM	BORE	EBHP
KFZ28A	24.5 GPM/93 LPM	3000 PSI/207 BAR	1000 RPM	1.102 in./28 mm	50
KFZ30A	28.0 GPM/106 LPM	2900 PSI/200 BAR	1000 RPM	1.181 in./30 mm	55
KFZ36A	32.2 GPM/122 LPM	2300 PSI/160 BAR	800 RPM	1.417 in./36 mm	50
KFZ36A	36.2 GPM/137 LPM	2050 PSI/140 BAR	900 RPM	1.417 in./36 mm	50
KFZ36A	40.0 GPM/153 LPM	1900 PSI/130 BAR	1000 RPM	1.417 in./36 mm	52
KFZ40A	45.0 GPM/170 LPM	1600 PSI/110 Bar	900 RPM	1.574 in./40 mm	49

Please refer to pages 42-45 for fittings, safety devices and other accessories. Performances refer to theoretical delivery with 100% volumetric efficiency. Under normal operating conditions, pump volumetric efficiency is over 95%. Please contact our technical staff in case of continuous, heavy-duty, or special applications.

# AGGRESSIVE ENVIRONMENT PUMPS MSN/MSZ SERIES

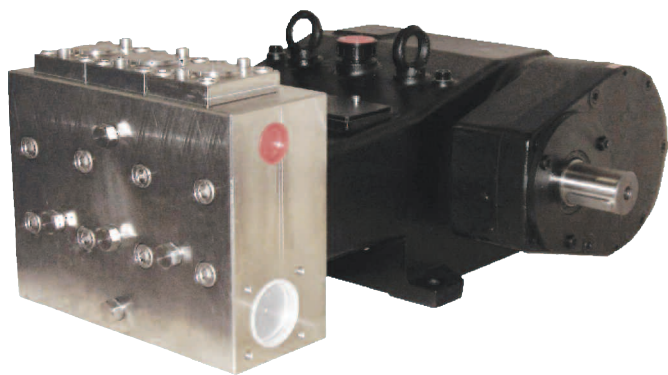

## FEATURES

- High Pressure Triplex Plunger Pump with gear box
- 316 Stainless Steel or Duplex Stainless Steel (ASTM A890) Manifold
- MSZ features 316 Stainless Steel wetted parts including valve plate and seat
- MSN feature 316 Stainless Steel wetted parts with 431 Stainless Steel valve plate and seat
- Gear reducer options in 1500 or 1800 RPM
- Gear Ratios: 1500 RPM=2.037:1, 1800 RPM=2.417:1

## MATERIALS

- Manifold in Duplex F51
- Plungers are Ceramic
- 316 Stainless Steel Valves and Wetted Parts
- MSN Features High Pressure ASI Stainless Valves
- Forged Steel Connecting Rods
- Pump Body in Cast Iron

## COMMON SPECIFICATIONS

- Maximum Inlet Pressure: ..... 45 PSI
- Maximum Fluid Temperature: ..... \*140° F
- Inlet Port Thread: ..... 2-1/2" BSP-F
- Discharge Port Thread: ..... 1-1/4" BSP-F
- Shaft Diameter: ..... 1.969"/50 mm
- Stroke: ..... 2.362"/60 mm
- Pump Dimensions: ..... 27.8" x 23.8" x 12.1"
- Crankcase Oil Capacity: ..... 338 oz. (10 liters)  
..... (use GP Series 220 Oil-see page 57)
- Shipping Weight: ..... .650 lbs./750 kg

## Product Group: V

\*Please consult technical guide or GP Sales Representative for Temperature/Inlet Pressure Information.

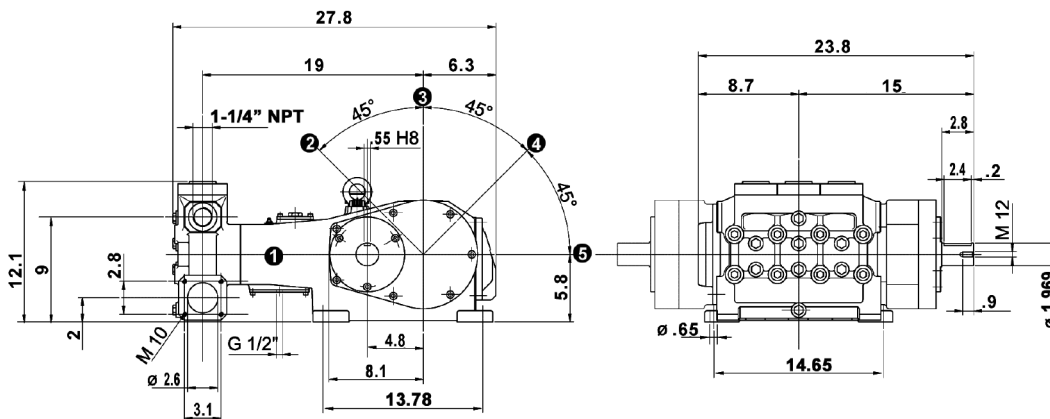

Note: All models come standard with crankshaft on right side (when facing manifold).

MODEL	GPM/LPM	PSI/BAR	BORE	EBHP
MSN36	35.4 GPM/134 LPM	4350 PSI/300 BAR	1.417 in./36 mm	105
MSN40	43.9 GPM/166 LPM	3500 PSI/241 BAR	1.575 in./40 mm	105
MSN45	55.5 GPM/210 LPM	2750 PSI/190 BAR	1.772 in./45 mm	104
MSN50	68.7 GPM/260 LPM	2250 PSI/155 BAR	1.969 in./50 mm	106
MSN55	83.0 GPM/314 LPM	1800 PSI/124 BAR	2.165 in./55 mm	102
MODEL	GPM/LPM	PSI/BAR	BORE	EBHP
MSZ45	55.5 GPM/210 LPM	1160 PSI/80 BAR	1.772 in./45 mm	37
MSZ50	68.7 GPM/260 LPM	1160 PSI/80 BAR	1.969 in./50 mm	46
MSZ55	83.0 GPM/314 LPM	1160 PSI/80 BAR	2.165 in./55 mm	55

# LHN/ LHZ SERIES

# AGGRESSIVE ENVIRONMENT PUMPS

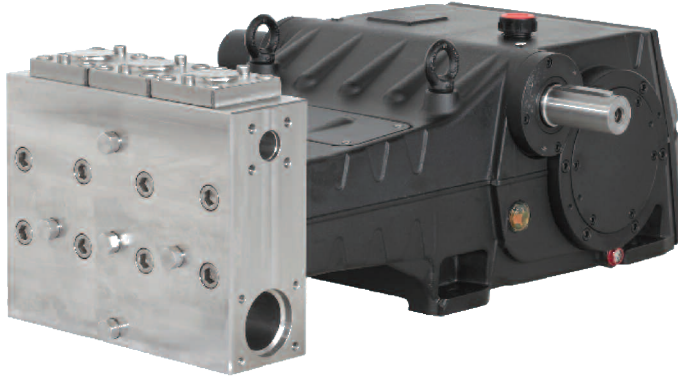

## FEATURES

- High Pressure Triplex Plunger Pump with internal gear reduction
- Self-adjusting Double Roller Bearings
- Rated for Continuous Duty
- Optional Drain/Priming Valve
- LHZ features 316 Stainless Steel wetted parts including valve plate and seat
- LHN features 316 Stainless Steel wetted parts with 431 Stainless Steel valve plate and seat

## MATERIALS

- Manifold in Duplex F51
- Plungers are Solid Ceramic
- 316 Stainless Steel Valves and Wetted Parts
- LHN Features High Pressure ASI Stainless Valves
- Forged Steel Connecting Rods
- Pump Body in Cast Iron

## COMMON SPECIFICATIONS

- Maximum Inlet Pressure: ..... 45 PSI
- Maximum Fluid Temperature: ..... \*140° F
- Inlet Port Thread: ..... 3" BSP-F Flange
- Discharge Port Thread: ..... 1-1/4" BSP-F Flange
- Shaft Diameter: ..... 1.969"/50 mm
- Stroke: ..... 3.546"/90 mm
- Pump Dimensions: ..... 36.3" x 25.8" x 13.57"
- Crankcase Oil Capacity: ..... 473.4 oz. (14 liters)  
..... (use GP Series 220 Oil-see page 57)
- Shipping Weight: ..... 850 lbs./386 kg

## Product Group: V

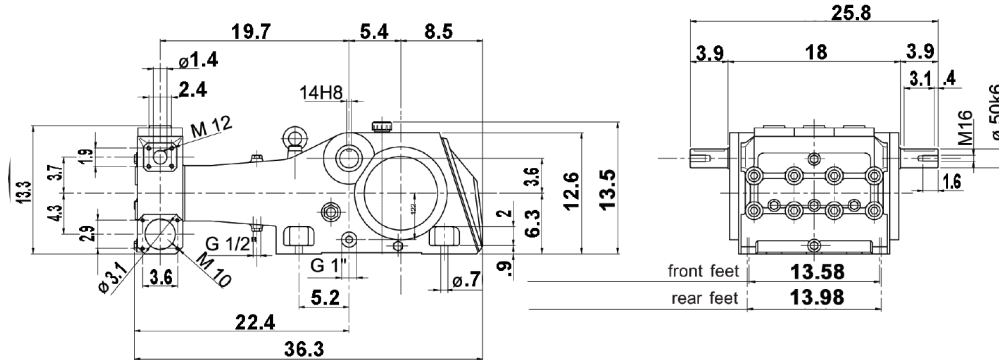

Note: All models come standard with crankshaft on right side (when facing manifold), specify "L" when ordering left hand version.

MODEL	GPM/LPM	PSI/BAR	RPM	BORE	EBHP
LHN4015	45.4 GPM/172 LPM	4350 PSI/300 BAR	1500 RPM	1.575 in./40 mm	136
LHN4017	49.7 GPM/188 LPM	4350 PSI/300 BAR	1750 RPM	1.575 in./40 mm	148
LHN4515	57.6 GPM/218 LPM	3500 PSI/241 BAR	1500 RPM	1.772 in./45 mm	138
LHN4517	62.9 GPM/238 LPM	3500 PSI/241 BAR	1750 RPM	1.772 in./45 mm	151
LHN5015	71.1 GPM/269 LPM	2900 PSI/200 BAR	1500 RPM	1.969 in./50 mm	142
LHN5017	77.4 GPM/293 LPM	2900 PSI/200 BAR	1750 RPM	1.969 in./50 mm	154
LHN5515	86.1 GPM/326 LPM	2300 PSI/159 BAR	1500 RPM	2.165 in./55 mm	136
LHN5517	93.8 GPM/355 LPM	2300 PSI/159 BAR	1750 RPM	2.165 in./55 mm	148
LHN6015	102.0 GPM/386 LPM	2050 PSI/141 BAR	1500 RPM	2.362 in./60 mm	144
LHN6017	112.0 GPM/424 LPM	2050 PSI/141 BAR	1750 RPM	2.362 in./60 mm	158
MODEL	GPM/LPM	PSI/BAR	RPM	BORE	EBHP
LHZ5015	71.1 GPM/269 LPM	1160 PSI/80 BAR	1500 RPM	1.969 in./50 mm	49
LHZ5017	77.4 GPM/293 LPM	1160 PSI/80 BAR	1750 RPM	1.969 in./50 mm	57
LHZ5515	86.1 GPM/326 LPM	1160 PSI/80 BAR	1500 RPM	2.165 in./55 mm	59
LHZ5517	93.8 GPM/355 LPM	1160 PSI/80 BAR	1750 RPM	2.165 in./55 mm	69
LHZ6015	102.0 GPM/386 LPM	1160 PSI/80 BAR	1500 RPM	2.362 in./60 mm	71
LHZ6017	112.0 GPM/424 LPM	1160 PSI/80 BAR	1750 RPM	2.362 in./60 mm	83

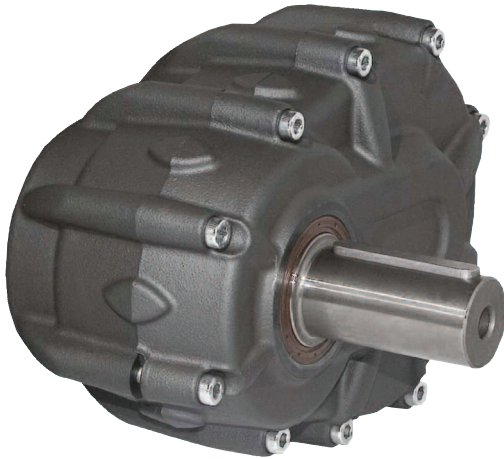

## OPTIONAL GEAR BOX FOR THE KF, HF, AND VF PUMPS

VF, HF and KF pumps can be supplied with an optional gear box available in three different ratios. The gear box can be mounted on the left or right side of the pump at four different angles.

### SPECIFICATIONS

- Gear Tothing: ..... Helicol
- Lubrication: ..... Splash
- Oil Qty.: ..... 13.5 oz. (.40 liters)
- Belt Drive Load: ..... None/Direct Drive Only
- Dry Weight: ..... 28 lbs./12.7 kg
- Output Shaft: ..... 40 mm

Part Number	Gearbox Ratios	Min. Input Speed RPM	Max. Input Speed RPM
34207301	R=1.25:1	625	1250
34207401	R=1.50:1	750	1500
34207501	R=1.83:1	915	1830

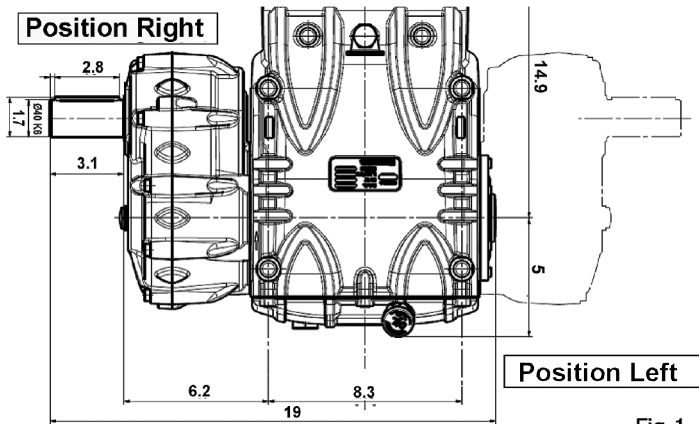

Fig.1

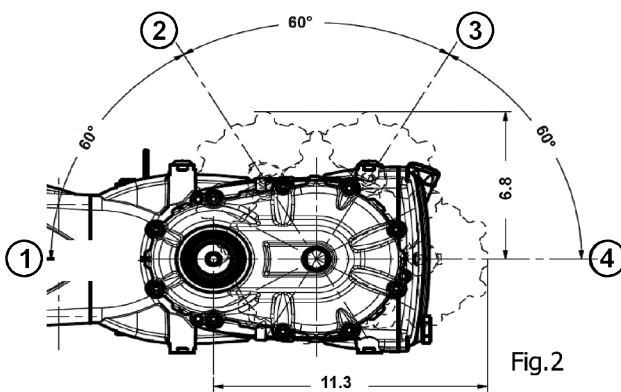

Fig.2

Gear box can be positioned on the left or right side of the pump in 4 different angles at 60°. Examples in **Figures 1** and **2** shows a gear box in position Right 1.

**NOTE: Direct Drive Only, No Belt Drive**

**NOTE:** When ordering a pump with a gear box, please ensure the input RPM coupled with the gearbox does NOT exceed the RPM rating of the pump.

**Example: KF30A has a maximum 1000 RPM**

Input 1800 and 1500 RPM  
 (Input RPM 1800 / 1.50 = 1200 RPM) The 1:1.5 gear box can **NOT** be used

(Input RPM 1500 / 1.50 = 1000 RPM) The 1:1.5 gear box **CAN** be used

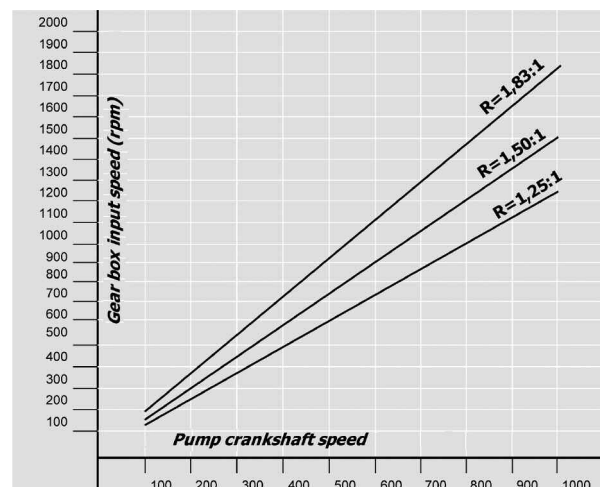

# NEW!

## HYDRAULIC DRIVE

### HYDRAULIC VERSIONS OF 51(TT), 60(TC) and 63(TX) SERIES PUMPS SAE Type "A" Flange, 5/8" Straight Shaft



**TT1509HA28**  
3.43 GPM  
2175 PSI  
2500 RPM



**TC1809HA17**  
3.30 GPM  
2165 PSI  
1750 RPM

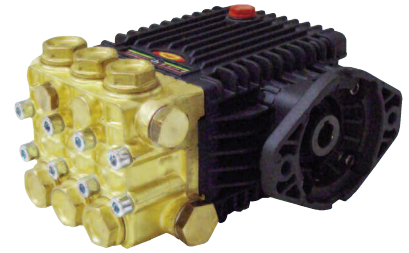

**TX1810HA17**  
4.20 GPM  
2405 PSI  
1750 RPM

### HYDRAULIC FLANGE/COUPLER FOR 47, 66(TSF/TSP) SERIES PUMPS



**ZFH47SB**  
SAE Type "B", 2 Bolt



**ZGH47SB**  
SAE Type "B", 7/8" Straight Shaft

### HYDRAULIC FLANGE/COUPLER FOR 70 (KE) SERIES PUMPS



**ZFH70SB**  
SAE Type "B", 2 and 4 Bolt



**ZGH70SB**  
SAE Type "B", 1" Straight Shaft

### HYDRAULIC FLANGE/COUPLER FOR 71 & 72 (KF, HF, VF and KS) SERIES PUMPS



**ZFH71SC**  
SAE Type "C", 2 and 4 Bolt

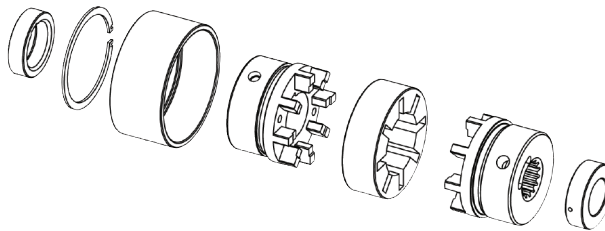

To be used with these GP Couplers:

ZGH71SCB.....	SAE-C-1-1/4" Parallel .....	40 mm Pump Hub and 1-1/4" Motor Hub, Blue Insert, 46 HP Max
ZGH71SCT.....	SAE-C-1-1/4" Parallel .....	40 mm Pump Hub and 1-1/4" Motor Hub, Black Insert, 46 HP+
ZGH71SCR.....	SAE-C-1-1/4" Parallel .....	40 mm Pump Hub and 1-1/4" Motor Hub, Red Insert, 25 HP Max
ZGH71SC14TB.....	SAE-C-14T 12/24DP .....	40 mm Pump Hub and Splined 14 Tooth 12/24 Motor Hub, Blue Insert, 46 HP Max
ZGH71SC14TT.....	SAE-C-14T 12/24DP .....	40 mm Pump Hub and Splined 14 Tooth 12/24 Motor Hub, Black Insert, 46 HP+
ZGH71SC14TR.....	SAE-C-14T 12/24DP .....	40 mm Pump Hub and Splined 14 Tooth 12/24 Motor Hub, Red Insert, 25 HP Max



# INDUSTRIAL PUMP FITTINGS & ACCESSORIES



**Fittings**

## Zinc-Coated Industrial Pump Fittings

### Product Group: J

680030	1/4" BSP-M x 1/4" NPT-M
680099	3/8" BSP-M x 1" BSP-M
680100	1/2" BSP-M x 1/4" NPT-F
680102	1/2" BSP-M x 1/2" NPT-M
680103	1/2" BSP-M x 1" BSP-M
680104	3/4" BSP-M x 3/4" BSP-M
680058	3/4" BSP-M x 3/4" NPT-M
680065	3/4" BSP-M x 3/4" NPT-F
680105	3/4" BSP-M x 1" BSP-M
680106	1" BSP-M x 1" BSP-M
680066	1" BSP-M x 1" NPT-M
680056	1" BSP-M x 1" NPT-F
680107	1 1/4" BSP-M x 1 1/4" BSP-M
680067	1 1/4" BSP-M x 1 1/4" NPT-M
680057	1 1/4" BSP-M x 1 1/4" NPT-F
680108	1 1/4" BSP-M x 1 1/2" BSP-M
680139	1 1/4" BSP-F x 1 1/4" NPT-M
680137	3" BSP-M x 3" NPT-M

## Zinc-Coated Steel Seal Rings with Rubber Insert

### Product Group: J

680109	1/4" BSP
680110	1/2" BSP
680111	3/4" BSP
680112	1" BSP
680113	1 1/4" BSP
680114	1 1/2" BSP
680138	3" BSP

## Zinc-Coated Steel Plugs

### Product Group: J

680115	1/4" BSP-M
680116	3/8" BSP-M
680117	1/2" BSP-M
680118	3/4" BSP-M
680119	1" BSP-M
680120	1 1/4" BSP-M
680121	1 1/2" BSP-M

## 300 Series Stainless Steel Seal Rings

### Product Group: J

680078	1/4" BSP
680079	3/8" BSP
680080	1/2" BSP
680082	3/4" BSP
680083	1" BSP
680084	1 1/4" BSP
680085	1 1/2" BSP



**680078**

## 300 Series Stainless Steel Fittings

### Product Group: J

F680022	1/2" NPT-M x 1/2" BSP-F
680075	3/4" BSP-M x 3/4" BSP-M
680062	3/4" BSP-M x 3/4" NPT-M
680059	3/4" BSP-M x 3/4" NPT-F
520150	3/4" BSP-M x 3/4" BSP-M
680076	3/4" BSP-M x 1" BSP-M
520151	3/4" BSP-M x 3/4" BSP-F, 90°
520263	3/4" BSP-M x 1/2"-14 NPT-M
680060	1" BSP-M x 1" NPT-F
680063	1" BSP-M x 1" NPT-M
680123	1 1/4" BSP-M x 1 1/4" BSP-M
680061	1 1/4" BSP-M x 1 1/4" NPT-F
680064	1 1/4" BSP-M x 1 1/4" NPT-M
520146	1 1/2" BSP-M x 1 1/2" NPT-F

## 300 Series Stainless Steel Plugs, Hex

### Product Group: J

680088	1/2" BSP-M
680090	3/4" BSP-M
680091	1" BSP-M
680092	1 1/4" BSP-M
680093	1 1/2" BSP-M

## Fittings for VF, VS, VK and SK Series Pumps

### Product Group: J

680086	1/2" Conical seat for discharge ports (supplied with pumps)
680087	Conical Gasket, G, 1/2" – SK and VF Pumps
680132	3/4" Conical seat for discharge ports (supplied with pumps)
680089	1/2" Gas - M Discharge Plug
680133	3/4" Gas - M Discharge Plug
680125	1/2" Gas - M x LF9 (HIP)
F1125	Inlet plug, G, 1 1/2" (SK and VS pumps)
F1126	Outlet plug, G, 1/2" HP, 9/16" (VF pumps)
F1128	Outlet plug, G, F, 3/4" (SK and VS pumps)
F1257	1/2" Gas Mounting Block Kit with bolts and o-ring (VF, VK Only)
F1127	3/4" Gas Mounting Block Kit with bolts and o-ring (VS and SK Only)
680081	1/2" BSP SS Seal Rings (copper washer for VF discharge ports)
680086	Conical seat for VH discharge ports (4 included with pump)
680038	1/2" BSP-M x 1/2" BSP-F SS Fittings
680136	1/2" Gas - M x 1/2" NPT-M, for use with 680132 below 15,000 PSI



**680086**

# INDUSTRIAL PUMP FITTINGS & ACCESSORIES

## Miscellaneous Accessories

### Product Group: J

680094	Belt Tension Slide Plate, rated for 40 horsepower
680095	Priming/Drain valve kit for MS series pumps (includes 3 valves)
680096	Priming/Drain valve kit for LH/MK/MKS series pumps (includes 3 valves)
190600	Priming/Drain valve kit for MS series pumps (includes 3 valves)
190601	Priming/Drain valve kit for MS series pumps (single valve)

## Industrial Unloaders

### Product Group: K

#### Manual bypass lever and automatic operation

	GPM	RATED	MAX	INLET	OUTLET	BYPASS	SHP WGHT
AL2	61.0 GPM	3050 PSI	2900 PSI	1" BSP-F	3/4" BSP-F	1 1/2" BSP-M	12.5 lbs.

#### Automatic only

VU2	61.0 GPM	3050 PSI	2900 PSI	1" BSP-F	3/4" BSP-F	1 1/2" BSP-M	12.5 lbs.
ZKX600	16.0 GPM	8700 PSI	8700 PSI	1/2" BSP-F	1/2" BSP-F	3/4" BSP-F	17.6 lbs.

	GPM	MAX	INLET	OUTLET	BYPASS	SHP WGHT
YVB16	21.0 GPM	8120 PSI	1/2" BSP-F	1/2" BSP-F	1/2" BSP-F	7.6 lbs.
YVB280SS	21.0 GPM	4500 PSI	1/2" BSP-F	1/2" BSP-F	1/2" BSP-F	2.7 lbs.
ZK3608SS	7.92 GPM	3600 PSI	3/8" BSP-F	3/8" BSP-M	(2) 3/8" BSP-F	2.3 lbs.
ZK7216SS	15.85 GPM	7200 PSI	1/2" BSP-F	1/2" BSP-F	(2) 1/2" BSP-F	5.9 lbs.

## Industrial Regulating Valves

### Product Group: K

	GPM	MAX	INLET	OUTLET	BYPASS	SHP WGHT
RV1/100	32.0 GPM	1450 PSI	3/4" BSP-F	N/A	3/4" BSP-F	9.5 lbs.
RV1/200	32.0 GPM	2900 PSI	3/4" BSP-F	N/A	3/4" BSP-F	9.5 lbs.
RV1/300	32.0 GPM	4350 PSI	3/4" BSP-F	N/A	3/4" BSP-F	9.5 lbs.
RV1/400	21.0 GPM	5800 PSI	3/4" BSP-F	N/A	3/4" BSP-F	9.5 lbs.
RV1/500	21.0 GPM	7250 PSI	3/4" BSP-F	N/A	3/4" BSP-F	9.5 lbs.
RV1/600	11.0 GPM	8700 PSI	3/4" BSP-F	N/A	3/4" BSP-F	9.5 lbs.
RV2	61.0 GPM	3050 PSI	1" BSP-F	3/4" BSP-F	1 1/4" BSP-M	10.0 lbs.
RV3/300	132.0 GPM	4350 PSI	1 1/4" BSP-F	N/A	1 1/4" BSP-M	26.4 lbs.
RV3/450	53.0	6500 PSI	1 1/4" BSP-F	N/A	1 1/4" BSP-M	26.4 lbs.
RV14/800	26.4 GPM	11600 PSI	Flanged/Block/VF	1/2" G-F Special	1" BSP-M	22 lbs.
RV14/1500	26.4 GPM	21750 PSI	Flanged/Block/VF	1/2" G-F Special	3/4" BSP-M	22 lbs.
RV14/1200VH	7.9 GPM	17400 PSI	Flanged/Block/VF	1/2" G-F Special	3/4" BSP-M	22 lbs.
RV14/1500A	7.9 GPM	21750 PSI	Flanged/Block/VF	1/2" G-F Special	3/4" BSP-M	22 lbs.

#### Features manual bypass lever and automatic operation

NL2	61.0 GPM	3050 PSI	1" BSP-F	3/4" BSP-F	1 1/2" BSP-F	12.5 lbs.
-----	----------	----------	----------	------------	--------------	-----------

#### 1.125" I.D. Hose Barb

ZKTIMAX	53.0 GPM	870 PSI	3/4" BSP-F	1/2" BSP-F	1" BSP-F	4.5 lbs.
---------	----------	---------	------------	------------	----------	----------

## Stainless Steel Regulating Valves

### Product Group: K

	GPM	MAX	INLET	OUTLET	BYPASS	SHP WGHT
ZKSX1	16.0 GPM	3600 PSI	1/2" BSP-F	-	1/2" BSP-F	2.3 lbs.
RX1/1450A	32.0 GPM	1450 PSI	3/4" NPT-F	N/A	3/4" NPT-F	11.0 lbs.
RX1/2900A	32.0 GPM	2900 PSI	3/4" NPT-F	N/A	3/4" NPT-F	11.0 lbs.
RX1/4350A	32.0 GPM	4350 PSI	3/4" NPT-F	N/A	3/4" NPT-F	11.0 lbs.
RX1/5800A	21.0 GPM	5800 PSI	3/4" NPT-F	N/A	3/4" NPT-F	11.0 lbs.
RX1/7250A	21.0 GPM	7250 PSI	3/4" NPT-F	N/A	3/4" NPT-F	11.0 lbs.
RX3/100	120.0 GPM	1450 PSI	1" BSP-F	3/4" BSP-F	1 1/4" BSP-F	11.0 lbs.
RX3/200	132.0 GPM	2900 PSI	1" BSP-F	3/4" BSP-F	1 1/4" BSP-F	11.0 lbs.
RX3/300	132.0 GPM	4350 PSI	1" BSP-F	3/4" BSP-F	1 1/4" BSP-F	11.0 lbs.
YVS280SS	21.0 GPM	4500 PSI	1/2" BSP-F	1/2" BSP-F	1/2" BSP-F	2.7 lbs.

**NEW!**



190601



AL2



ZKX600



YVB16



ZK3608SS



VU2



RV1/300



ZKSX1



RX1

# INDUSTRIAL PUMP FITTINGS & ACCESSORIES



**100315**

## Jetter Valve for use in Sewer Cleaning Applications

*Product Group: D*

	DESCRIPTION	SHP WGHT
100315	Use with TT Pumps (Replaces Valve Cap)	0.7 lbs.
100316	Use with EZ Pumps (Replaces Valve Cap)	0.7 lbs.
100317	Use with 47 Series Pumps (Replaces Valve Cap, coarse thread)	0.7 lbs.
100072	Use with 47 Series Pumps (Replaces Valve Cap, fine thread)	0.7 lbs.



**SV12/1000**

## Industrial Safety Relief Valves

*Product Group: K*

	GPM	MAX	INLET	DISCHARGE	SHP WGHT
SV2/100	50.0 GPM	1450 PSI	1/2" BSP-M	Bottom	2.5 lbs.
SV2/200	50.0 GPM	2900 PSI	1/2" BSP-M	Bottom	2.5 lbs.
SV2/300	50.0 GPM	4350 PSI	1/2" BSP-M	Bottom	2.5 lbs.
SV2/400	50.0 GPM	5800 PSI	1/2" BSP-M	Bottom	2.5 lbs.
SV2/500	50.0 GPM	7250 PSI	1/2" BSP-M	Bottom	2.5 lbs.
SV3/200	132.0 GPM	2900 PSI	3/4" BSP-M	Bottom	2.5 lbs.
SV3/100	132.0 GPM	1450 PSI	3/4" BSP-M	Bottom	2.5 lbs.
SV3/300	132.0 GPM	4350 PSI	3/4" BSP-M	Bottom	2.5 lbs.
SV12/800	26.4 GPM	11600 PSI	1/2" BSP-M	Bottom	2.5 lbs.
SV12/1000	26.4 GPM	14500 PSI	1/2" BSP-M	Bottom	7.5 lbs.
SV12/1100	26.4 GPM	15950 PSI	1/2" BSP-M	Bottom	7.5 lbs.
SV12/1250	26.4 GPM	18125 PSI	1/2" BSP-M	Bottom	7.5 lbs.
SV12/1500	26.4 GPM	21750 PSI	1/2" BSP-M	Bottom	7.5 lbs.

*Stainless Steel*

SX2/100	50.0 GPM	1450 PSI	1/2" BSP-M	Bottom	2.5 lbs.
SX2/200	50.0 GPM	2900 PSI	1/2" BSP-M	Bottom	2.5 lbs.
SX2/300	50.0 GPM	4350 PSI	1/2" BSP-M	Bottom	2.5 lbs.
SX2/400	50.0 GPM	5800 PSI	1/2" BSP-M	Bottom	2.5 lbs.
SX2/500	50.0 GPM	7250 PSI	1/2" BSP-M	Bottom	2.5 lbs.



**UDI**

## Industrial Valves

*Product Group: K*

Check Valve for KE, HF & KF Pumps

	GPM	RATED	MAX	INLET	OUTLET	SHP WGHT
UD1	48.0 GPM	75 PSI	3650 PSI	3/4" BSP-M	3/4" BSP-F	1.5 lbs.



**FPN12**

## Industrial Pneumatic Valves

*Product Group: K*

	GPM	MAX	INLET	OUTLET	BYPASS	SHP WGHT
PN/RV2	61.0 GPM	3050 PSI	1" BSP-F	3/4" BSP-F	1 1/4" BSP-M	17.5 lbs.
PN2	61.0 GPM	7250 PSI	1 1/2" BSP-F	1 1/2" BSP-M	1 1/2" BSP-M	55.0 lbs.
PN3/160	132.0 GPM	2350 PSI	1 1/2" BSP-F	1 1/2" BSP-F	1 1/2" BSP-F	55.3 lbs.
PN3/240	111.0 GPM	3500 PSI	1 1/2" BSP-F	1 1/2" BSP-M	1 1/2" BSP-M	55.0 lbs.
PN3/300	79.0 GPM	4350 PSI	1 1/2" BSP-F	1 1/2" BSP-M	1 1/2" BSP-M	55.0 lbs.
PNRV14/800	26.4 GPM	11600 PSI	Flanged/Block	3/4" BSP-F	1" BSP-F	17.6 lbs.
PNRV14/VH	26.4 GPM	17400 PSI	Flanged/Block	1/2" BSP-F	1" BSP-F	17.6 lbs.
PNRV14/1500	26.4 GPM	21750 PSI	Flanged/Block	3/4" BSP-F	1" BSP-F	17.6 lbs.

*Features Check Valve*

PN/VU2	61.0 GPM	3050 PSI	1" BSP-F	3/4" BSP-F	1 1/4" BSP-M	17.5 lbs.
FPN12	21.0 GPM	17400 PSI	3/8" BSP-F	3/8" BSP-F	3/8" BSP-F	55.3 lbs.
FPN14	21.0 GPM	21750 PSI	3/8" BSP-F	3/8" BSP-F	3/8" BSP-F	55.3 lbs.



**VP12**

## Industrial Foot Valve

*Product Group: K*

	GPM	MAX	INLET	OUTLET	BYPASS	SHP WGHT
VP12	21.0 GPM	21750 PSI	3/8" BSP-F	3/8" BSP-F	3/8" BSP-F	22.5 lbs.

# INDUSTRIAL PUMP FITTINGS & ACCESSORIES

## Industrial Pulsation Dampeners

Product Group: K

	MATERIAL	GPM	RATED	INLET	SHP WGHT
*A4X	316 Stainless Steel	16 GPM	3050 PSI	1/2" BSP-M	7.0 lbs.
*A7	Forged Steel	43 GPM	3050 PSI	1/2" BSP-M	7.0 lbs.
*A7S	Forged Steel	43 GPM	4750 PSI	3/4" BSP-M	12.0 lbs.
*A7X	316 Stainless Steel	43 GPM	2150 PSI	3/4" BSP-M	8.5 lbs.
*A15	Forged Steel	105.6 GPM	4750 PSI	3/4" BSP-M	15.0 lbs.
*A15X	316 Stainless Steel	105.6 GPM	2150 PSI	3/4" BSP-M	15.0 lbs.

\*190417 Recharge kit and fitting (100038 recharge kit, 680135 adapter fitting)



A4X

## Industrial Spray Gun

Product Group: K

	DESCRIPTION	GPM	MAX	SHP WGHT
ZP87SS	SS Professional Gun	15.85 GPM	8700 PSI	3.5 lbs.
ZP87SSL19	SS Gun with 19" Lance	15.85 GPM	8700 PSI	4.9 lbs.
ZP87SSL39	SS Gun with 39" Lance	15.85 GPM	8700 PSI	6.1 lbs.
ZP87SSL19S	SS Gun with 19" Lance and Shoulder Support	15.85 GPM	8700 PSI	5.6 lbs.
ZP87SSL39S	SS Gun with 39" Lance and Shoulder Support	15.85 GPM	8700 PSI	7.2 lbs.



ZP87SSL19S

	DESCRIPTION	GPM	MAX	INLET	OUTLET	SHP WGHT
P12	Dump Gun	21.0 GPM	21750 PSI	1/2" BSP-M	1/4" BSP-M	12.0 lbs.
P45	Gun with 20" Lance	21.0 GPM	7250 PSI	1/2" BSP-F	1/4" BSP-F	5.0 lbs.
P47	Gun with 39" Lance	21.0 GPM	7250 PSI	1/2" BSP-F	1/4" BSP-F	10.0 lbs.
PS12	Submersible Dump Gun	21.0 GPM	21750 PSI	1/2" BSP-F	1/4" BSP-F	12.5 lbs.
YG7221	Rear Entry Gun	21.0 GPM	8100 PSI	1/2" BSP-F	1/2" BSP-F	5.0 lbs.



P12

## Spray Gun with Lance and Side Grip

Product Group: K

	DESCRIPTION	GPM	RATED	MAX	INLET	OUTLET	MAX TEMP	SHP WGHT
YG7221/L31	31" Lance	21.0 GPM	7250 PSI	8100 PSI	1/2" BSP-F	1/2" BSP-M	210° F	7.0 lbs.
YG7221/L51	48" Lance	21.0 GPM	7250 PSI	8100 PSI	1/2" BSP-F	1/2" BSP-M	210° F	7.0 lbs.



YG7221-L51

## Industrial Rotating Nozzles

	ORIFICE	GPM	MAX	INLET	MAX TEMP	SHP WGHT
ZRMAX112	1.10	2.02 to 4.73 GPM	11000 PSI	3/8" BSP-F	176° F	2.2 lbs.
ZRMAX113	1.35	3.32 to 7.78 GPM	11000 PSI	3/8" BSP-F	176° F	2.2 lbs.
ZRMAX114	1.55	4.44 to 10.40 GPM	11000 PSI	3/8" BSP-F	176° F	2.2 lbs.
ZRMAX115	1.80	5.71 to 13.39 GPM	11000 PSI	3/8" BSP-F	176° F	2.2 lbs.

## Titanium Nozzle Seat

	ORIFICE	GPM	MAX	INLET	MAX TEMP	SHP WGHT
ZRMAX2220	.9	1.4 - 4.7	22000	M14 x 1/2"	140° F	2.64 lbs.
ZRMAX2225	1.0	1.8 - 6.0	22000	M14 x 1/2"	140° F	2.64 lbs.
ZRMAX2231	1.1	2.2 - 7.3	22000	M14 x 1/2"	140° F	2.64 lbs.
ZRMAX2245	1.2	2.6 - 8.6	22000	M14 x 1/2"	140° F	2.64 lbs.
ZRMAX2259	1.35	3.4 - 11.2	22000	M14 x 1/2"	140° F	2.64 lbs.



ZRMAX2220



ZRMAX112

## Industrial Filters

Product Group: K

	DESCRIPTION	GPM	MESH/MICRON	INLET	OUTLET	SHP WGHT
F50/80	Stainless Steel, Two-Stage	10.5 GPM	10/70	1" BSP-F	1" BSP-F	12.0 lbs.
F10	Aluminum	15.8 GPM	60/80	1 1/2" BSP-F	1 1/2" BSP-F	3.5 lbs.
F60	Stainless Steel	52.0 GPM	15 to 100	2" BSP-F	2" BSP-M	33.0 lbs.
F20	Aluminum	53.0 GPM	60/80/110	2" BSP-F	2" BSP-F	13.0 lbs.
F30	Plastic	53.0 GPM	50/100	2" BSP-M	2" BSP-M	3.8 lbs.
F40	Plastic	120.0 GPM	50/100	3" BSP-M	3" BSP-M	6.6 lbs.
639273	Plastic	55.0 GPM	50/297	2" NPT-F	2" NPT-F	4 lbs.
639276	Plastic	125.0 GPM	50/297	3" NPT-F	3" NPT-F	7 lbs.



F30

# VEHICLE CLEANING APPLICATIONS



## **Self-service wash**

- Single or multi-bay applications
- Spot-free rinse application
- Chemical application
- Pre-soak/Tire-motor cleaner
- Foam brush
- Reclaim water
- Weep-systems

## **Automatic wash**

- Roll-over automatic
- Spot-free rinse application
- Pre-soak systems
- Weep systems
- Foam application

## **Tunnel wash**

- Prep station
- Brush wetting
- Detergent application
- Spot-free rinse application
- Bay wash-down

## **Mobile vehicle wash**

- Truck mounted wash units
- Spot-free rinse application

# VEHICLE CLEANING PUMPS

## Emperor Pumps

Emperor HTS, 47HT Series, Triplex plunger pump features exclusive HT technology. Specifically designed to handle the rigorous duty cycles, high temperatures and chemicals associated with self-service car wash applications. Also ideal for use in carpet cleaning and other high pressure cleaning applications.

**Max. Inlet Pressure: 125 PSI Max. Fluid Temperature: 185° F Inlet Port Thread: 1/2" - 14 BSP-F Discharge Port Thread: 3/8" - 19 BSP-F Shaft Diameter: .945 in./24 mm Pump Dimensions: 12.2" x 9.2" x 6.9" 12.4" x 10" x 6.9" (with rails) Max. Inlet Vacuum: 9 ft. water (7.9 in. Hg) Crankcase Oil Capacity: 40.6 oz. Use GP Series 100 Oil, (see page 57) Product Group: X**

	GPM	PSI	RPM	BORE	STROKE	HP	SHP WGHT
HTS2210S	2.6/4.0	2300	950/1450	.866 in/22 mm	.394 in/10 mm	4.1/6.3	32 lbs.
HTS2212S	3.2/4.75	2300	950/1450	.866 in/22 mm	.472 in/12 mm	5/7.5	32 lbs.
HTS2215S	4.0/5.0	2300	950/1200	.866 in/22 mm	.591 in/15 mm	4.1/7.8	32 lbs.

Emperor HTX, 63HT Series, Triplex plunger pump features exclusive HT technology. Specifically designed to handle the rigorous duty cycles, high temperatures and chemicals associated with self-service car wash applications. Also ideal for use in carpet cleaning and other high pressure cleaning applications. This pump offers a compact and economical design.

**Max. Inlet Pressure: 125 PSI Max. Fluid Temperature: 185° F Inlet Port Thread: 1/2" - 14 BSP-F Discharge Port Thread: 3/8" - 19 BSP-F Shaft Diameter: .945 in./24 mm Pump Dimensions: 8.4" x 8.3" x 4.8" 8.4" x 8.3" x 5.6" (with rails) Max. Inlet Vacuum: 3 ft. water (2.9 in. Hg) Crankcase Oil Capacity: 14 oz. Use GP Series 100 Oil, (see page 57) Product Group: X**

	GPM	PSI	RPM	BORE	STROKE	HP	SHP WGHT
HTX1810S	2.7/3.1	2000	1450/1750	.709 in./18 mm	.394 in./10 mm	3.5/4.2	18 lbs.
HTX1812S	3.2/3.8	2000	1450/1750	.709 in./18 mm	.472 in/12 mm	4.3/5.2	18 lbs.
HTX1813S	3.5	2500	1450	.709 in./18 mm	.512 in/13 mm	6	18 lbs.

Emperor HTF, 66HT Series, Triplex plunger pump features exclusive HT technology. Designed for use in prep units, conveyor and multiple gun applications. Excellent for carpet cleaning and for use in industrial plant systems where hot water is required.

**Max. Inlet Pressure: 125 PSI Max. Fluid Temperature: 185° F Inlet Port Thread: 3/4" - 14 BSP-F Discharge Port Thread: 3/8" - 19 BSP-F Shaft Diameter: .945 in./24 mm Pump Dimensions: 13.27" x 9.6" x 6.23" 13.4" x 9.8" x 7.5" (with rails) Max. Inlet Vacuum: 9 ft. water (7.9 in. Hg) Crankcase Oil Capacity: 31 oz. Use GP Series 100 Oil, (see page 57) Product Group: X**

	GPM	PSI	RPM	BORE	STROKE	HP	SHP WGHT
HTF2018S	4.0/5.0/7.5	3600	950/1200/1750	.787 in/20 mm	.748 in/18 mm	10/12/18.5	41 lbs.
HTF2221S	8.5/10.2	3000	1450/1750	.866 in/22 mm	.826 in/21 mm	17.5/21	41 lbs.
HTF2421S	10.0/12.0	3000/2500	1450/1750	.945 in/24 mm	.826 in/21 mm	20.5	41 lbs.

Emperor HTW, 69HT Series, Triplex plunger pump features exclusive HT technology. Designed for touchless car wash systems, multiple gun systems and industrial plant systems where hot water is required.

**Max. Inlet Pressure: 125 PSI Max. Fluid Temperature: 185° F Inlet Port Thread: 1" - 11 BSP-F Discharge Port Thread: 3/4" - 14 BSP-F Shaft Diameter: 1.378 in./35 mm Pump Dimensions: 13" x 11.9" x 7.3" Max. Inlet Vacuum: 9 ft. water (7.9 in. Hg) Crankcase Oil Capacity: 50.7 oz. Use GP Series 100 Oil, (see page 57) Product Group: X**

	GPM	PSI	RPM	BORE	STROKE	HP	SHP WGHT
HTW3624S	18.0	1200	1000	1.417 in/36 mm	.945 in/24 mm	19.5	57 lbs.



**HTS2210S**



**HTX1810S**

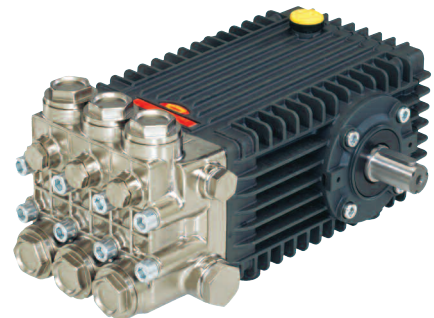

**HTF2018S**



**HTW3624S**

# VEHICLE CLEANING PUMPS EMPEROR HTCK SERIES



**HTCK3623S**  
70 Series

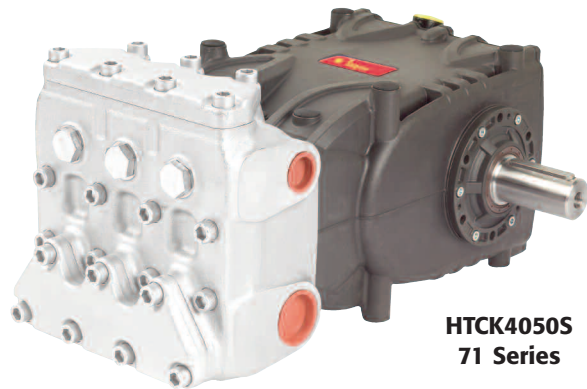

**HTCK4050S**  
71 Series

## FEATURES

- Features patent-pending "high tech" packings
- Solid ceramic plungers
- Patent-pending inlet/outlet valve cage
- Nickel-plated forged brass manifold with an exclusive lifetime warranty
- Heavy-duty taper roller bearings
- Specifically designed to handle rigorous duty cycles, high temperatures and chemicals
- Ideal for use in car wash and other high pressure cleaning applications

## COMMON SPECIFICATIONS

- Maximum Inlet Pressure: ..... 125 PSI
- Maximum Fluid Temperature: ..... 185° F
- Inlet Port Thread: ..... 1" NPT-F (HTCK3623S)  
..... 1-1/2" NPT-F (HTCK4050S)
- Discharge Port Thread: ..... 1/2" NPT-F (HTCK3623S)  
..... 1" NPT-F (HTCK4050S)
- Shaft Diameter: ..... 1.181"/30 mm (HTCK3623S)  
..... 1.575"/40 mm (HTCK4050S)
- Maximum Inlet Vacuum: ..... 3 ft. Water (2.6" Hg)
- Pump Dimensions: ..... 15.3" x 13.4" x 7.7" (HTCK3623S)  
..... 20.7" x 14.5" x 9.9" (HTCK4050S)
- Crankcase Oil Capacity: 64.2 oz. (1.90 liters) (HTCK3623S)  
..... 124.4 oz. (3.68 liters) (HTCK4050S)  
..... (use GP Series 220 Oil-see page 57)

## MATERIALS

- High resistance light alloy crankcase
- Nickel-plated forged brass manifold
- Taper roller bearings
- Special antifriction light alloy connecting rods
- Forged alloy steel crankshaft, hardened, tempered and nitrided
- Cast iron piston guide, nickel treated
- Solid ceramic plungers
- Stainless steel valves

## Product Group: X

**HTCK3623S**

**HTCK4050S**

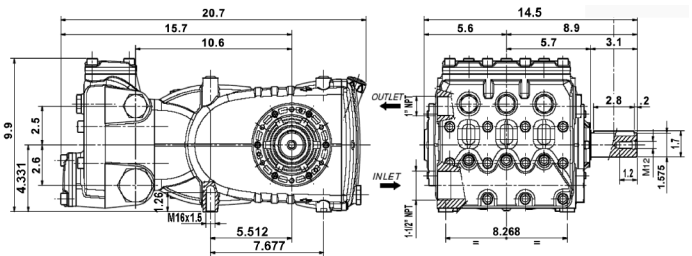
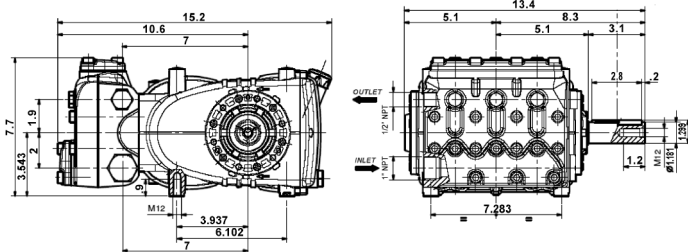

MODEL	GPM/LPM	PSI/BAR	BORE	STROKE	HP	WEIGHT
HTCK3623S	21.0 GPM/79.4 LPM 25.0 GPM/94.6 LPM	1500 PSI/103 BAR 1300 PSI/89.6 BAR	1.4 in./36 mm	.9 in./23 mm	22	79.6 lbs.
HT125 RCK	Pump Rails					
HTCK4050S	36.0 GPM/136.2 LPM	1500 PSI/103 BAR	1.6 in./40 mm	1.9 in./50 mm	38	157 lbs.
HT150 RCK ZUH40	Pump Rails Universal Hub, 40 mm					

## Vehicle Cleaning Pumps

Car Wash Series 47 Triplex Plunger Pump – Forged brass manifold with an exclusive lifetime warranty. The preferred pump frame in the car wash self-service industry. Solid ceramic plungers with continuously lubricated packings.

**Max. Inlet Pressure: 125 PSI Max. Fluid Temperature: 165° F Inlet Port Thread: 1/2" - 14 BSP-F**  
**Discharge Port Thread: 3/8" - 19 BSP-F Shaft Diameter: .945 in./24 mm (dual shaft)**  
**Pump Dimensions: 11.4" x 10.8" x 6.9" Max. Inlet Vacuum: 9 ft. water (7.9 in. Hg)**  
**Crankcase Oil Capacity: 33.8 oz. Use GP Series 100 Oil, (see page 57) Product Group: X**

	GPM	PSI	RPM	BORE	STROKE	HP	SHP WGHT
CW2004	4.0 GPM	2000 PSI	1750 RPM	.787 in./20 mm	.394 in./10 mm	5.5 EBHP	30.0 lbs.
CW2040	5.0 GPM	2500 PSI	1250 RPM	.787 in./20 mm	.630 in./16 mm	8.6 EBHP	30.0 lbs.
CW24	5.0 GPM	2500 PSI	1250 RPM	.787 in./20 mm	.630 in./16 mm	8.6 EBHP	30.0 lbs.
CW3040	5.0 GPM	3000 PSI	1250 RPM	.787 in./20 mm	.630 in./16 mm	10.3 EBHP	32.0 lbs.

- 190237 CW2040 Pump and Retrofit Rail and 24 MM H Bushing for Cat 310 Replacement
- 190238 CW2040 Pump and Retrofit Rail and 8" OD Pulley for Cat 310 Replacement
- 190239 CW3040 Pump and Retrofit Rail for Cat 530 Replacement
- 190245 CW3040L Pump and Retrofit Rail and H Bushing for Cat 530 Replacement

Car Wash Series 69 Triplex Plunger Pump – Forged brass manifold with an exclusive lifetime warranty. The preferred pump frame in the two-gun prep conveyor and tunnel car wash industry. Solid ceramic plungers with continuously lubricated packings.

**Max. Inlet Pressure: 125 PSI Max. Fluid Temperature: 165° F Inlet Port Thread: 3/4" - 14 BSP-F**  
**Discharge Port Thread: 3/8" - 19 BSP-F Shaft Diameter: 1.378 in./35 mm**  
**Pump Dimensions: 13.0" x 11.9" x 7.3" Crankcase Oil Capacity: 50.7 oz. Use GP Series 8090 Oil, (see page 57) Max. Inlet Vacuum: 2 ft. water (1.8 in. Hg) Product Group: Y**

	GPM	PSI	RPM	BORE	STROKE	HP	SHP WGHT
CW1012	10.0 GPM	1200 PSI	750 RPM	1.18 in./30 mm	.946 in./24 mm	8.2 EBHP	45.0 lbs.
CW1012	12.0 GPM	1000 PSI	900 RPM	1.18 in./30 mm	.946 in./24 mm	8.2 EBHP	45.0 lbs.

Car Wash Series 76 Triplex Plunger Pump – Forged brass manifold with an exclusive lifetime warranty. Oversized bronze connecting rods for maximum life. Solid ceramic plungers with continuously lubricated packings.

**Max. Inlet Pressure: 125 PSI Max. Fluid Temperature: 165° F Inlet Port Thread: 1" - 11 BSP-F**  
**Discharge Port Thread: 3/4" - 14 BSP-F Shaft Diameter: 1.378 in./35 mm**  
**Pump Dimensions: 15.6" x 14.0" x 9.5" Max. Inlet Vacuum: 9 ft. water (7.9 in. Hg)**  
**Crankcase Oil Capacity: 91.0 oz. Use GP Series 8090 Oil, (see page 57) Product Group: Y**

	GPM	PSI	RPM	BORE	STROKE	HP	SHP WGHT
CW61	17.0 GPM	1200 PSI	1000 RPM	1.417 in./36 mm	.945 in./24 mm	14.0 EBHP	92.0 lbs.
CW81	21.0 GPM	1200 PSI	1000 RPM	1.417 in./36 mm	1.102 in./28 mm	17.3 EBHP	92.0 lbs.

Car Wash Series 77 Sixplex Plunger Pump – Forged brass manifold with an exclusive lifetime warranty. Most widely used pump frame in the touchless car wash industry. Dual manifolds utilizing a common crankcase for efficient performance. (Recommend Series 80/90 Oil, part number 100734.)

**Max. Inlet Pressure: 125 PSI Max. Fluid Temperature: 165° F Inlet Port Thread: Dual 1" - 11 NPT-F**  
**Discharge Port Thread: Dual 3/4" - 14 NPT-F Shaft Diameter: 1.378 in./35 mm**  
**Crankcase Oil Capacity: 2 quarts Use GP Series 8090 Oil, (see page 57)**  
**Pump Dimensions: 22.1" x 14.0" x 9.7" Max. Inlet Required: Flooded Product Group: Y**

	GPM	PSI	RPM	BORE	STROKE	HP	SHP WGHT
CW1541	41.0 GPM	1200 PSI	1000 RPM	1.417 in./36 mm	1.102 in./28 mm	33.7 EBHP	156 lbs.



CW2040



CW1012



CW61



CW1541

See pages 50-54 for Vehicle Cleaning Accessories.

All car wash pumps are covered under warranty for damage caused by fresh water wash out for the life of the pump.



# VEHICLE CLEANING ACCESSORIES

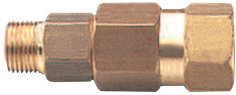

**YSW38MFB**

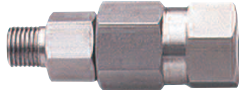

**YSW38MFSS**



**SW38MF90N**



**SW14MFN**



**560002**



**105140**

## Swivels

*Product Group: H*

	DESCRIPTION	GPM	RATED	MAX	INLET	OUTLET	MAX TEMP	SHP WGHT
YSW38MFB	Medium Resistance, Brass	10.5 GPM	3650 PSI	4050 PSI	3/8" BSP-M	3/8" BSP-F	320° F	0.3 lbs.
YSW14MFSS	Medium Resistance, SS	10.5 GPM	5100 PSI	5650 PSI	3/8" BSP-M	3/8" BSP-F	320° F	0.3 lbs.
YSW38MFSS	Medium Resistance, SS	10.5 GPM	5100 PSI	5650 PSI	1/4" BSP-M	1/4" BSP-F	320° F	0.3 lbs.
YSW14MFB	Medium Resistance, Brass	10.5 GPM	3650 PSI	4050 PSI	1/4" BSP-M	1/4" BSP-F	320° F	0.3 lbs.

	DESCRIPTION	GPM	RATED	INLET	OUTLET	MAX TEMP	SHP WGHT
SW14MFN	Nickel-Plated	12.0 GPM	1500 PSI	1/4" NPT-M	1/4" NPT-F	200° F	0.3 lbs.
SW38MF90N	Nickel-Plated, 90° Elbow	12.0 GPM	1500 PSI	3/8" NPT-M	3/8" NPT-F	200° F	0.5 lbs.
SW38MFN	Nickel-Plated	12.0 GPM	1500 PSI	3/8" NPT-M	3/8" NPT-F	200° F	0.3 lbs.

## Squeegees

*Product Group: I*

	DESCRIPTION
560002	5 Foot Tapered Wood Handle
PXW20075	30" Foam Rubber Squeegee Head, cleans dirt out of the deepest cracks, even on rough surfaces
560001	Assembled Squeegee Head and Handle

## Nozzle Packs

*Product Group: I*

	DESCRIPTION	SHP WGHT
105140	Nozzle Kit for Laser Wash 4000, contains all nozzles for arch, 19 Nozzles	0.5 lbs.
105144	Nozzle Kit for D & S 5000 – Gantry, 16 Nozzles	0.5 lbs.
105145	Nozzle Kit for D & S 5000 – Blaster, 12 Nozzles	0.5 lbs.
105154	Nozzle Kit for SSA Futura, 30 – 1/8" NPT Nozzles	3.0 lbs.
105162	Nozzle Kit for Oasis, Front Bridge of 8530 Windcar, 14 Nozzles	1.4 lbs.
105163	Nozzle Kit for Oasis, Main Bridge 8530 Windcar, 18 Nozzles	1.8 lbs.
105164	Nozzle Kit for Oasis, Front Bridge 8530 Windvan, 16 Nozzles	1.6 lbs.
105165	Nozzle Kit for Oasis, Main Bridge 8530 Windvan, 20 Nozzles	2.0 lbs.
105166	Nozzle Kit for Oasis 8530 Oscillating Windcar/Windvan, 12 Nozzles	1.2 lbs.
105167	Nozzle Kit for Oasis 9120 Windvan, 24 Nozzles	2.4 lbs.
105168	Nozzle Kit for Oasis Undercarriage, 27 Nozzles	2.7 lbs.
105169	Nozzle Kit for Oasis Rocker Panel Sprayers, 10 Nozzles	1.0 lbs.
105191	Nozzle Kit for Hydrospray Cobra-Tower, 16 Nozzles	1.6 lbs.
105192	Nozzle Kit for Hydrospray Cobra-Wheel/Undercarriage, 20 Nozzles	2.0 lbs.
105193	Nozzle Kit for Hydrospray Rainmaker-Tower, 9 Nozzles	1.0 lbs.

*105162, 105163, 105166 will replace all nozzles on Windcar unit  
105164, 105165, 105166 will replace all nozzles on Windvan unit*

# VEHICLE CLEANING ACCESSORIES

## Regulators – Great for Multiple Gun Prep Units

Product Group: S

	DESCRIPTION	GPM	RATED	MAX	INLET	OUTLET	MAX TEMP	SHP WGHT
100878	Brass	5.0 GPM	2000 PSI	3650 PSI	3/8" NPT-F	1/4" NPT-F	190° F	1.3 lbs.
100892	Nickel Plated	5.0 GPM	2000 PSI	3650 PSI	3/8" NPT-F	1/4" NPT-F	220° F	1.4 lbs.
ZKSX1	316 SS	16.0 GPM	3600 PSI	5400 PSI	1/2" BSP-F	1/2" BSP-F	185° F	2.3 lbs.
100992*	Nickel Plated	10.0 GPM	2000 PSI	3650 PSI	1/2" NPT-F	1/4" NPT-F	220° F	2.8 lbs.

\*Coming soon in 2010



## Balanced Relief Valves

Product Group: T

	GPM	RATED	MAX	INLET	BYPASS	MAX TEMP	SHP WGHT
YBRV624	6.3 GPM	2200 PSI	2450 PSI	3/8" BSP-F	3/8" BSP-F	195° F	0.8 lbs.
YBRV624D	6.3 GPM	2200 PSI	2450 PSI	(2) 3/8" BSP-F	3/8" BSP-F	195° F	1.0 lbs.
100268	6.3 GPM	300 PSI	N/A	(2) 3/8" BSP-F	3/8" BSP-F	195° F	1.0 lbs.
100269	6.3 GPM	300 PSI	N/A	3/8" BSP-F	3/8" BSP-F	195° F	0.8 lbs.
YBRV5325	53.0 GPM	2600 PSI	2900 PSI	3/4" BSP-F	1/2" BSP-F	195° F	2.0 lbs.

YBRV624D



YBRV624

## Unloaders

Product Group: S

	GPM	RATED	MAX	INLET	OUTLET	BYPASS	MAX TEMP	SHP WGHT
YU831	8.0 GPM	3200 PSI	3650 PSI	3/8" NPT-F	3/8" NPT-F	3/8" NPT-F	195° F	1.4 lbs.
YU831D	8.0 GPM	3200 PSI	3650 PSI	(2) 3/8" NPT-F	3/8" NPT-F	(2) 3/8" NPT-F	195° F	1.5 lbs.
ZK4010	10.5 GPM	4000 PSI	4000 PSI	3/8" BSP-F	3/8" BSP-M	(2) 3/8" BSP-F	185° F	2.3 lbs.
YU2121	21.0 GPM	2200 PSI	2450 PSI	(2) 1/2" NPT-F	1/2" NPT-F	(2) 1/2" NPT-F	200° F	3.1 lbs.
YU5221	53.0 GPM	2200 PSI	2450 PSI	1" NPT-F	1" NPT-F	1" NPT-F	200° F	4.5 lbs.



YU2121

YU5221



ZK4010

## Check Valves

Product Group: T

	DESCRIPTION	GPM	RATED	MAX	INLET	MAX TEMP	SHP WGHT
YCV14FSS	Stainless Steel	6.5 GPM	5800 PSI	6500 PSI	1/4" BSP-F	195° F	0.5 lbs.
YCV38FSS	Stainless Steel	10.5 GPM	5800 PSI	6500 PSI	3/8" BSP-F	195° F	0.5 lbs.
YCV12FB	Brass	21.0 GPM	2200 PSI	2300 PSI	1/2" BSP-F	195° F	0.5 lbs.
YCV12FSS	Stainless Steel	21.0 GPM	5800 PSI	6500 PSI	1/2" BSP-F	195° F	0.5 lbs.
YCV34FB	Brass	47.6 GPM	2200 PSI	2300 PSI	3/4" BSP-F	195° F	0.8 lbs.
YCV34FSS	Stainless Steel	47.6 GPM	5800 PSI	6500 PSI	3/4" BSP-F	195° F	0.8 lbs.



YCV12FB

## Accumulators

Product Group: K

	DESCRIPTION	GPM	RATED	MAX	INLET	SHP WGHT
686011	Non-Rechargeable	10.0 GPM	3000 PSI	3000 PSI	1/2" NPT-M	2.5 lbs.
686028	Rechargeable	10.0 GPM	3000 PSI	3000 PSI	1/2" NPT-M	2.5 lbs.
686010	Rechargeable	40.0 GPM	3000 PSI	3000 PSI	1" NPT-M	7.0 lbs.



686011

## Rear Entry Spray Guns

Product Group: I

	DESCRIPTION	GPM	RATED	MAX	INLET	OUTLET	MAX TEMP	SHP WGHT
YRL2640		8.0 GPM	3650 PSI	4000 PSI	3/8" NPT-F	1/4" NPT-F	320° F	1.0 lbs.
YRL2640W	Weep Seat	8.0 GPM	3650 PSI	4000 PSI	3/8" NPT-F	1/4" NPT-F	320° F	1.0 lbs.
YG4000		10.0 GPM	4500 PSI	5000 PSI	3/8" NPT-F	1/4" NPT-F	320° F	1.8 lbs.
YG4000W	Weep Seat	10.5 GPM	3650 PSI	4050 PSI	3/8" NPT-F	1/4" NPT-F	320° F	1.8 lbs.
YG4010		10.5 GPM	4500 PSI	5000 PSI	3/8" NPT-F	1/4" NPT-F	320° F	1.2 lbs.
YG4010W	Weep Seat	10.5 GPM	4500 PSI	5000 PSI	3/8" NPT-F	1/4" NPT-F	320° F	1.2 lbs.
YG5000		10.0 GPM	5000 PSI	5000 PSI	3/8" NPT-F	1/4" NPT-F	320° F	1.2 lbs.
YG5000W	Weep Seat	10.0 GPM	5000 PSI	5000 PSI	3/8" NPT-F	1/4" NPT-F	320° F	1.2 lbs.
DG5010		10.0 GPM	5000 PSI	5000 PSI	3/8" NPT-F	1/4" NPT-F	320° F	1.4 lbs.
DG5010W	Weep Seat	10.0 GPM	5000 PSI	5000 PSI	3/8" NPT-F	1/4" NPT-F	320° F	1.4 lbs.



YRL2640W

# VEHICLE CLEANING ACCESSORIES



**YL20PNS**



**YL20PNB**

## Insulated Lances

*Product Group: I*

	LENGTH	GPM	RATED	MAX	INLET	OUTLET	MAX TEMP	SHP WGHT
YL20PNS	20" Straight	10.5 GPM	3650 PSI	4050 PSI	1/4" NPT-M	1/4" NPT-F	320° F	1.1 lbs.
YL24PNS	24" Straight	10.5 GPM	3650 PSI	4050 PSI	1/4" NPT-M	1/4" NPT-F	320° F	1.3 lbs.
YL27PNS	27" Straight	10.5 GPM	3650 PSI	4050 PSI	1/4" NPT-M	1/4" NPT-F	320° F	1.4 lbs.
YL20PNB	20" Bend	10.5 GPM	3650 PSI	4050 PSI	1/4" NPT-M	1/4" NPT-F	320° F	1.1 lbs.
YL24PNB	24" Bend	10.5 GPM	3650 PSI	4050 PSI	1/4" NPT-M	1/4" NPT-F	320° F	1.3 lbs.
YL27PNB	27" Bend	10.5 GPM	3650 PSI	4050 PSI	1/4" NPT-M	1/4" NPT-F	320° F	1.4 lbs.

## Flexible Lances

	LENGTH	GPM	RATED	MAX	INLET	OUTLET	MAX TEMP	SHP WGHT
DL18FWRD	18"	10.0 GPM	2250 PSI	2500 PSI	1/4" NPT-M	1/8" NPT-F	200° F	1.1 lbs.
DL18FWBL	18"	10.0 GPM	2250 PSI	2500 PSI	1/4" NPT-M	1/8" NPT-F	200° F	1.1 lbs.
DL18FWBK	18"	10.0 GPM	2250 PSI	2500 PSI	1/4" NPT-M	1/8" NPT-F	200° F	1.1 lbs.
DL18FWRDM	18"	10.0 GPM	2250 PSI	2500 PSI	1/4" NPT-M	1/4" NPT-M	200° F	1.1 lbs.
DL18FWBLM	18"	10.0 GPM	2250 PSI	2500 PSI	1/4" NPT-M	1/4" NPT-M	200° F	1.1 lbs.
DL18FWBKM	18"	10.0 GPM	2250 PSI	2500 PSI	1/4" NPT-M	1/4" NPT-M	200° F	1.1 lbs.

## Stainless Steel Flexible Lances

DL18FRDSS	18"	10.0 GPM	2250 PSI	2500 PSI	1/4" NPT-M	1/8" NPT-F	200° F	0.9 lbs.
DL18FBLSS	18"	10.0 GPM	2250 PSI	2500 PSI	1/4" NPT-M	1/8" NPT-F	200° F	0.9 lbs.
DL18FBKSS	18"	10.0 GPM	2250 PSI	2500 PSI	1/4" NPT-M	1/8" NPT-F	200° F	0.9 lbs.



**DL18FWBK**



**DL18FWBL**



**DL18FWRD**



**DL18FBLSS**

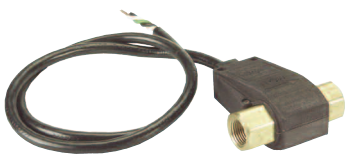

**100934**

## Reedless Flow Switch

*Product Group: D*

*TMT Inline Flowswitch, 5 amp micro switch, minimum flow 0.5 GPM, activation, 48" 18 awg lead, no spring, uses magnets for all movements.*

	GPM	MAX	MAX TEMP	INLET	OUTLET	VOLTAGE	MATERIAL	SHP WGHT
100934	12.0 GPM	5000 PSI	180° F	3/8" NPT-F	3/8" NPT-F	250 VAC	Brass	0.3 lbs.
100953	12.0 GPM	5800 PSI	180° F	3/8" NPT-F	3/8" NPT-F	250 VAC	SS	0.5 lbs.

# VEHICLE CLEANING ACCESSORIES

## Chemical Injectors – Brass Body, SS Nozzle, Viton Elastomers and Ceramic Ball

	ORIFICE	GPM	MAX	INLET	OUTLET	MAX TEMP	HOSE BARB	SHP WGHT
100947	1.6 mm	2.0 to 3.0 GPM	4500 PSI	3/8" NPT-M	3/8" NPT-M	190° F	1/4"	0.4 lbs.
100948	1.8 mm	2.0 to 3.0 GPM	4500 PSI	3/8" NPT-M	3/8" NPT-M	190° F	1/4"	0.4 lbs.
100949	2.1 mm	3.0 to 5.0 GPM	4500 PSI	3/8" NPT-M	3/8" NPT-M	190° F	1/4"	0.4 lbs.
100950	2.3 mm	5.0 to 8.0 GPM	4500 PSI	3/8" NPT-M	3/8" NPT-M	190° F	1/4"	0.4 lbs.

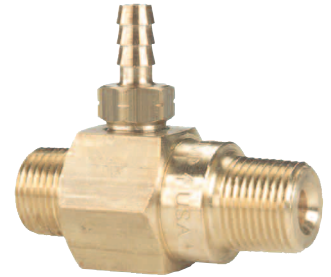

100948

## Chemical Injectors – Brass Body, SS Nozzle, Viton Elastomers and SS Ball

	ORIFICE	GPM	MAX	INLET	OUTLET	MAX TEMP	HOSE BARB	SHP WGHT
100913	1.45 mm	1.0 to 2.0 GPM	4000 PSI	3/8" NPT-M	3/8" NPT-M	190° F	1/4"	0.4 lbs.
100615	1.8 mm	2.0 to 3.0 GPM	4000 PSI	3/8" NPT-M	3/8" NPT-M	190° F	1/4"	0.4 lbs.
100511	2.1 mm	3.0 to 5.0 GPM	4000 PSI	3/8" NPT-M	3/8" NPT-M	190° F	1/4"	0.4 lbs.



100615

## Chemical Injectors – Brass Body, SS Nozzle, Viton Elastomers and Teflon Ball

	ORIFICE	GPM	MAX	INLET	OUTLET	MAX TEMP	HOSE BARB	SHP WGHT
100871	1.5 mm	1.0 to 2.0 GPM	4000 PSI	3/8" NPT-M	3/8" NPT-M	190° F	1/4"	0.3 lbs.
100872	2.3 mm	5.0 to 8.0 GPM	4000 PSI	3/8" NPT-M	3/8" NPT-M	190° F	1/4"	0.3 lbs.
100854	1.5 mm	1.0 to 2.0 GPM	4000 PSI	3/8" NPT-M	3/8" NPT-M	190° F	1/4" Dual	0.4 lbs.
100855	2.3 mm	5.0 to 8.0 GPM	4000 PSI	3/8" NPT-M	3/8" NPT-M	190° F	1/4" Dual	0.4 lbs.



100872

## Chemical Injectors – SS Body, SS Nozzle, Special Elastomers and SS Ball

	ORIFICE	GPM	MAX	INLET	OUTLET	MAX TEMP	HOSE BARB	SHP WGHT
100336S	1.45 mm	1.0 to 2.0 GPM	5500 PSI	3/8" NPT-M	3/8" NPT-M	190° F	1/4"	0.4 lbs.
100334S	2.1 mm	2.0 to 4.0 GPM	5500 PSI	3/8" NPT-M	3/8" NPT-M	190° F	1/4"	0.4 lbs.
100333S	2.2 mm	3.0 to 5.0 GPM	5500 PSI	3/8" NPT-M	3/8" NPT-M	190° F	1/4"	0.4 lbs.
100339S	2.5 mm	5.0 to 8.0 GPM	5500 PSI	3/8" NPT-M	3/8" NPT-M	190° F	1/4"	0.4 lbs.
100541S	2.1 mm	3.0 to 5.0 GPM	5500 PSI	3/8" NPT-M	3/8" NPT-M	190° F	1/4" Dual	0.5 lbs.

Repair Kits Available

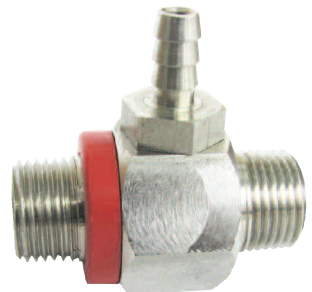

100336S

## Chemical Injectors – SS Body, SS Nozzle, EPDM Elastomers and SS Ball

	ORIFICE	GPM	MAX	INLET	OUTLET	MAX TEMP	HOSE BARB	SHP WGHT
100075	1.45 mm	1.0 to 2.0 GPM	5500 PSI	3/8" NPT-M	3/8" NPT-M	190° F	1/4"	0.4 lbs.
100093	2.1 mm	2.0 to 4.0 GPM	5500 PSI	3/8" NPT-M	3/8" NPT-M	190° F	1/4"	0.4 lbs.
100074	2.2 mm	3.0 to 5.0 GPM	5500 PSI	3/8" NPT-M	3/8" NPT-M	190° F	1/4"	0.4 lbs.
100076	2.5 mm	5.0 to 8.0 GPM	5500 PSI	3/8" NPT-M	3/8" NPT-M	190° F	1/4"	0.4 lbs.
100541	2.1 mm	3.0 to 5.0 GPM	5500 PSI	3/8" NPT-M	3/8" NPT-M	190° F	1/4" Dual	0.5 lbs.

Repair Kits Available

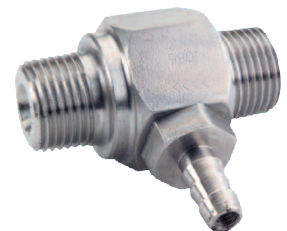

100075

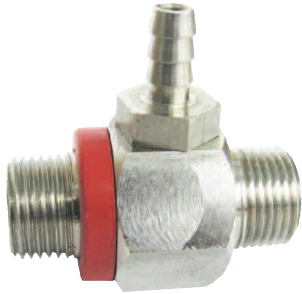

**100336**

## Chemical Injectors – SS Body, SS Nozzle, Viton Elastomers and SS Ball

	ORIFICE	GPM	MAX	INLET	OUTLET	MAX TEMP	HOSE BARB	SHP WGHT
100336	1.45 mm	1.0 to 2.0 GPM	5500 PSI	3/8" NPT-M	3/8" NPT-M	190° F	1/4"	0.4 lbs.
100094	1.6 mm	2.0 to 3.0 GPM	5500 PSI	3/8" NPT-M	3/8" NPT-M	190° F	1/4"	0.4 lbs.
100835	1.8 mm	2.0 to 3.0 GPM	5500 PSI	3/8" NPT-M	3/8" NPT-M	190° F	1/4"	0.4 lbs.
100334	2.1 mm	2.0 to 4.0 GPM	5500 PSI	3/8" NPT-M	3/8" NPT-M	190° F	1/4"	0.4 lbs.
100333	2.2 mm	3.0 to 5.0 GPM	5500 PSI	3/8" NPT-M	3/8" NPT-M	190° F	1/4"	0.4 lbs.
100339	2.5 mm	5.0 to 8.0 GPM	5500 PSI	3/8" NPT-M	3/8" NPT-M	190° F	1/4"	0.4 lbs.

Repair Kits Available



**100938**

## Chemical Injectors – CPVC Body, CPVC Nozzle, Kynar Hose Barb and Teflon Ball

	ORIFICE	GPM	MAX PSI	O-RING MAT.	INLET	OUTLET	MAX TEMP	HOSE BARB	SHP WGHT
100938	1.6 mm	2.0 to 3.0 GPM	250	Viton	3/8" NPT-M	3/8" NPT-M	190° F	1/4"	0.3 lbs.
100853	2.1 mm	3.0 to 5.0 GPM	250	EPDM	3/8" NPT-M	3/8" NPT-M	190° F	1/4"	0.3 lbs.
100955	1.4 mm	1.0 to 2.0 GPM	250	Viton	1/2" NPT-M	1/2" NPT-M	190° F	1/4"	0.4 lbs.
100956	1.6 mm	2.0 to 3.0 GPM	250	Viton	1/2" NPT-M	1/2" NPT-M	190° F	1/4"	0.4 lbs.
100957	2.1 mm	3.0 to 5.0 GPM	250	EPDM	1/2" NPT-M	1/2" NPT-M	190° F	1/4"	0.4 lbs.



**100966**

## Chemical Injectors – Kynar Body, SS Nozzle, Kynar Hose Barb and Teflon Ball

	ORIFICE	GPM	O-RING MAT.	INLET	OUTLET	MAX TEMP	HOSE BARB	SHP WGHT
100965	1.45 mm	1.0 to 2.0 GPM	Viton	Flange	Flange	190° F	1/4"	0.3 lbs
100966	1.45 mm	1.0 to 2.0 GPM	Viton	Flange	Flange	190° F	1/4" Dual	0.4 lbs
100967	2.1 mm	3.0 to 5.0 GPM	Viton	Flange	Flange	190° F	1/4"	0.3 lbs.
100968	1.45 mm	1.0 to 2.0 GPM	EPDM	Flange	Flange	190° F	1/4"	0.3 lbs.
100969	1.45 mm	1.0 to 2.0 GPM	Butyl	Flange	Flange	190° F	1/4"	0.3 lbs.



**100096**

## Chemical Injectors – SS Body, SS Nozzle, Kynar Hose Barb and Teflon Ball

	ORIFICE	GPM	MAX PSI	O-RING MAT.	INLET	OUTLET	MAX TEMP	HOSE BARB	SHP WGHT
100096	1.45 mm	1.0 to 2.0 GPM	250	EPDM	3/8" NPT-M	3/8" NPT-M	190° F	1/4"	0.4 lbs.
100097	2.2 mm	3.0 to 5.0 GPM	250	EPDM	3/8" NPT-M	3/8" NPT-M	190° F	1/4"	0.4 lbs.

1



LUBRICANTS

TRAPPED PRESSURE

UNLOADERS

FLOW SENSITIVE UNLOADERS

REGULATING VALVES

SAFETY RELIEF VALVES

NEEDLE VALVES

PUMP THERMAL PROTECTORS

CHECK VALVES

CHEMICAL INJECTORS

SPRAY GUNS

LANCES

HOSE REELS

HIGH-PRESSURE SPRAY TIPS

ADJUSTABLE AND ROTATING

NOZZLES

TANK CLEANING NOZZLES

COUPLERS AND FITTINGS

INLET FILTERS AND STRAINERS

THERMOSTATS

PRESSURE SWITCHES

FLOW SWITCHES

SWIVELS

ACCUMULATORS



**ZGR1000**

## Gear Reducers and Multipliers

*Product Group: F*

	DESCRIPTION	SHP WGHT
ZGR0750	2.4 to 1 Reduction for 3/4" Shafted Engines, 3 to 5 HP, J609A (Series 49 and 50 at 1450 RPM)	5.0 lbs.
ZGR1000	2.2 to 1 Reduction for 1" Shafted Engines, 7 to 18 HP, J609B (Series 47 at 1450 RPM)	11.0 lbs.
ZGR1125	2.2 to 1 Reduction for 1 1/8" Shafted Engines, 7 to 18 HP, J609B (Series 47 and 48 at 1450 RPM)	11.0 lbs.
SGR1125	Mounting Plate for Flat mounting (ZGR1000 and ZGR1125)	0.5 lbs.
ZGRS1000	2.2 to 1, 1" Shafted Engines, up to 25 hp, J609A Flange	9.5 lbs.
ZGRS1125	2.2 to 1, 1 1/8" Shafted Engines, up to 25 hp, J609A Flange	9.5 lbs.



**YGR1000**

	DESCRIPTION	SHP WGHT
YGR0750	2.4 to 1 Reduction, 3/4" Shafted Engines, 3 to 5 HP, J609A (Series 49 and 50 at 1450 RPM)	4.0 lbs.
YGR1000	2.2 to 1 Reduction, Dual Bearing, 1" Shafted Engines, 11 to 18 HP, J609B (Series 47 at 1450 RPM)	6.0 lbs.
YGR1000P	2.2 to 1 Reduction, Dual Bearings, 1" Shafted Engines, 11 to 24 HP, J609B (Series 47 and 66 at 1450 RPM)	6.0 lbs.
YGR1125	2.2 to 1 Reduction, 1 1/8" Shaft, Dual Bearings, 11 to 18 HP, J609B (Series 47 and 48 at 1450 RPM)	6.0 lbs.
YGR1125P	2.2 to 1 Reduction, Dual Bearings, 1 1/8" Shafted Engines, 11 to 24 HP, J609B (Series 47, 48 and 66 at 1450 RPM)	6.0 lbs.
ZGRPTO	1 to 1.9 Multiplier, 540 RPM PTO, 1 3/8" Spline Shaft, up to 10 HP Pumps	9.5 lbs.



**ZGL100**

## Flex Coupler

*Product Group: F*

	DESCRIPTION	SHP WGHT
ZG56C	24 mm x 5/8" (Finger)	1.2 lbs.
ZG145TC	24 mm x 7/8" (Finger)	1.3 lbs.
ZG184TC	24 mm x 1 1/8" (Finger)	1.5 lbs.
ZG202	24 mm x 1 3/8" (Finger)	2.5 lbs.
ZGL100	24 mm x 1" (Jaw) for use with ZF811 on 8 to 11 HP Engines	3.0 lbs.



**ZG184TC**

## Flanges

*Product Group: F*

*\*Ensure pump and motor RPM's match when selecting flanges*



**ZF184**

	DESCRIPTION	SHP WGHT
ZF184N	For NEMA-C Electric 184TC Frame, use with ZG184TC Coupler (Series 63 and 44 Series)	3.5 lbs.
ZF184	For NEMA-C Electric Motors 184TC Frame, 3 and 5 HP (Series 50 Pumps)	3.0 lbs.
640042	Gas Flange Adapter (TT/TP Series 51 Pumps)	0.3 lbs.
ZF213215	For NEMA-C Electric Motors, 213TC, 215TC and 184TC Frames, 5 and 7-1/2 HP (Series 47 and 48 Pumps)	4.0 lbs.
ZF56145	For NEMA-C Electric Motors, 56C, 145TC and 182TC Frames, 1-1/2 HP and 2 HP (Series 49 and 50 Pumps)	1.5 lbs.
ZF811	Gas Engine Flange for 8 to 11 HP Gas Engines (TT9351 or TT9441 Pumps)	3.0 lbs.
ZFWWS	Gas Engine Flange for 3.5 to 8 HP Gas Engines (TT/TP Series 51 Pumps)	2.0 lbs.
ZFWWU	For NEMA-C Electric Motors 56C Frame (TT/TP Series 51 Pumps)	2.0 lbs.
ZFH70SB	Hydraulic Flange, SAE-B (KE Series), call GP sales for more information	6.0 lbs.
ZFH71SC	Hydraulic Flange, SAE-C (KF, HF, VF, KS Series), call GP sales for more information	6.0 lbs.

## Pulleys *Product Group: F*

2 Groove, A Section Aluminum Pulley

	DESCRIPTION	SHP WGHT
ZP100	3.94 in./100 mm	1.0 lbs.
ZP140	5.51 in./140 mm	1.4 lbs.
ZP160	6.30 in./160 mm	1.8 lbs.
190225	Pulley and Rail Kit (includes 639015 and (2) 540015)	1.5 lbs.
639015	1 Groove, B Section, Aluminum, 8" Outer Diameter, 24 mm Hub	1.5 lbs.
ZP4140	4 Groove, B Section, Aluminum, 32 mm	2.5 lbs.



**ZP-Pulleys**

## Browning Type "H" Pulley Bushing *Product Group: F*

	DESCRIPTION	SHP WGHT
ZBBH24	24 mm	0.5 lbs.
ZBBH32	32 mm	0.5 lbs.
ZBBH35	35 mm	0.5 lbs.
ZUH40	40 mm, Universal	1.0 lbs.

## Clutches *Product Group: C*

	DESCRIPTION	SHP WGHT
100687	12 Volt Double Groove Clutch Adapter Kit for 47 Series Pumps	11.0 lbs.
100688	12 Volt Double Groove Clutch Adapter Kit for 44, 50 and 63 Series Pumps	11.0 lbs.
100717	12 Volt Single Groove Clutch Adapter Kit for 47 Series Pumps	11.0 lbs.
100718	12 Volt Single Groove Clutch Adapter Kit for 44, 50 and 63 Series Pumps	11.0 lbs.
100719	24 Volt Double Groove Clutch Adapter Kit for 47 Series Pumps	11.0 lbs.
100720	24 Volt Double Groove Clutch Adapter Kit for 44 and 50 Series Pumps	11.0 lbs.



**100687**

## Oil *Product Group: M*

	DESCRIPTION	SHP WGHT
100295	Series 100 Oil, 16 oz. Bottle	3.0 lbs.
100552	Series 100 Oil, 2 1/2 Gallons	25.0 lbs.
100450	Series 220 Industrial Oil, 2 1/2 Gallons	25.0 lbs.
100734	Series 8090 Oil, 2 1/2 Gallons	25.0 lbs.
100256	Grease Gun Kit, 3 oz. Tube with Gun	2.0 lbs.
100264	Packing Lubricant, 3 oz. Tube	0.70 lbs.
100278	Industrial Packing Lubricant, 12 oz. Tube	0.75 lbs.



**Oil**

### Bulk Packaged Oil *Product Group: B*

100214	Series 100 Oil, 6-pack of 16 oz. Bottles	7.0 lbs.
100216	Series 100 Oil, 24-pack of 16 oz. Bottles	25.0 lbs.
100553	Series 100 Oil, 2 - 2 1/2 Gallons	50.0 lbs.
100219	Series 100 Oil, 15 Gallon Plastic Drum	117.0 lbs.
100016	Series 220 Industrial Oil, 6-pack of 16 oz. Bottles	7.0 lbs.
100217	Series 220 Industrial Oil, 5 Gallons	50.0 lbs.
100735	Series 8090 Oil, 2.5 Gallon Twin Pack	50.0 lbs.

Series 100 oil is 30 weight

Series 220 oil is 50 weight

Series 8090 is 80/90 weight gear lube

## Oil Drain Kits *Product Group: M*

	DESCRIPTION	SHP WGHT
190446	Oil drain kit, 1/4", For Series 60, 63, 47, 44, 50, 66 pumps	1.5 lbs.
190447	Oil drain kit, 3/8", For Series 69, 70, 76, 77 pumps	1.5 lbs.
190448	Oil drain kit, 1/2", For Series 71, 72, MSS, VS pumps	1.5 lbs.



**Oil Drain Kit**





**YU815**



**YU831**



**ZK5813**



**ZK4010**

## Trapped Pressure Unloaders

*Product Group: S*

Single Port Unloader White Spring

	GPM	RATED	MAX	INLET	OUTLET	BYPASS	MAX TEMP	SHW WGHT
YU815	8 GPM	1450 PSI	1750 PSI	3/8" NPT-F	3/8" NPT-F	3/8" NPT-F	195° F	1.5 lbs.
YU815RK	8 GPM	1450 PSI	1750 PSI	3/8" NPT-F	3/8" NPT-F	3/8" NPT-F	195° F	1.5 lbs.

Multi-port unloader

YU815D	8 GPM	1450 PSI	1750 PSI	(2) 3/8" NPT-F	3/8" NPT-F	(2) 3/8" NPT-F	195° F	1.5 lbs.
YU815DRK	8 GPM	1450 PSI	1750 PSI	(2) 3/8" NPT-F	3/8" NPT-F	(2) 3/8" NPT-F	195° F	1.5 lbs.

Single Port Unloader Blue Spring

YU831	8 GPM	3200 PSI	3650 PSI	3/8" NPT-F	3/8" NPT-F	3/8" NPT-F	195° F	1.4 lbs.
-------	-------	----------	----------	------------	------------	------------	--------	----------

Multi-port unloader

YU831D	8 GPM	3200 PSI	3650 PSI	(2) 3/8" NPT-F	3/8" NPT-F	(2) 3/8" NPT-F	195° F	1.5 lbs.
--------	-------	----------	----------	----------------	------------	----------------	--------	----------

Multi-port unloader with a built-in downstream chemical injector

YU831DI	8 GPM	3200 PSI	3650 PSI	(2) 3/8" NPT-F	3/8" NPT-M	(2) 3/8" NPT-F	195° F	2.0 lbs.
---------	-------	----------	----------	----------------	------------	----------------	--------	----------

Multi-port unloader with 2.1 mm Adjustable Injector (2.6 to 4 GPM) with knob

YU831DIRK	8 GPM	3200 PSI	3650 PSI	(2) 3/8" BSP-F	3/8" BSP-F	(2) 3/8" BSP-F	195° F	2.0 lbs.
-----------	-------	----------	----------	----------------	------------	----------------	--------	----------

Unloader with pressure adjustment knob

YU831RK	8 GPM	3200 PSI	3650 PSI	3/8" NPT-F	3/8" NPT-F	3/8" NPT-F	195° F	1.5 lbs.
---------	-------	----------	----------	------------	------------	------------	--------	----------

*Product Group: N*

YUKNOB	Pressure Adjusting Knob for YU815 and YU831 Unloaders							0.2 lbs.
--------	---	--	--	--	--	--	--	----------

*Product Group: S*

PULSAR3	8.1 GPM	3200 PSI	3650 PSI	3/8" NPT-F	3/8" NPT-F	3/8" NPT-F	195° F	1.5 lbs.
PULSAR3KHP	8.1 GPM	3600 PSI	4000 PSI	3/8" NPT-F	3/8" NPT-F	3/8" NPT-F	195° F	1.5 lbs.
PULSAR3HP	8.1 GPM	3600 PSI	4000 PSI	3/8" NPT-F	3/8" NPT-F	3/8" NPT-F	195° F	1.0 lbs.

Unloader with Easy Start

PULSAR3KHPEZ	8.0 GPM	3600 PSI	4000 PSI	3/8" NPT-F	3/8" NPT-F	(2) 3/8" NPT-F	195° F	1.6 lbs.
P3KHPEZF21	8.0 GPM	3600 PSI	4000 PSI	3/8" NPT-F	3/8" NPT-F	3/8" NPT-F	195° F	1.6 lbs.

PULSAR3 with Viton Packings

Y60012205	8.0 GPM	1500 PSI		3/8" NPT-F	3/8" NPT-F	3/8" NPT-F	195° F	1.5 lbs.
-----------	---------	----------	--	------------	------------	------------	--------	----------

ZK3608	2.11 to 8.0 GPM		3600 PSI	3/8" BSP-F	3/8" BSP-M	(2) 3/8" BSP-F	165° F	2.3 lbs.
ZK4010	2.11 to 10.5 GPM		4000 PSI	3/8" BSP-F	3/8" BSP-M	(2) 3/8" BSP-F	185° F	2.3 lbs.
ZK5813	2.11 to 13.2 GPM		5800 PSI	1/2" BSP-F	1/2" BSP-M	(2) 1/2" BSP-F	185° F	6.2 lbs.

## Trapped Pressure Unloaders

*Product Group: S*

	GPM	RATED	MAX	INLET	OUTLET	BYPASS	MAX TEMP	SHP WGHT
Yellow Spring YU2121	21 GPM	2200 PSI	2450 PSI	(2) 1/2" NPT-F	1/2" NPT-F	(2) 1/2" NPT-F	200° F	3.1 lbs.
White Spring YUW2121	21 GPM	2200 PSI	2450 PSI	(2) 1/2" NPT-F	1/2" NPT-F	1/2" NPT-F	200° F	3.1 lbs.
Green Spring YU2140	21 GPM	4050 PSI	4350 PSI	(2) 1/2" NPT-F	1/2" NPT-F	(2) 1/2" NPT-F	200° F	3.1 lbs.
Blue Spring YUB2140	21 GPM	4050 PSI	4350 PSI	(2) 1/2" NPT-F	1/2" NPT-F	1/2" NPT-F	200° F	3.1 lbs.
With Microswitch, 10 Amp YU2140MS	21 GPM	4050 PSI	4350 PSI	(2) 1/2" NPT-F	1/2" NPT-F	1/2" NPT-F	200° F	3.1 lbs.
Hi-flow YU5221	53.0 GPM	2200 PSI	2450 PSI	1" NPT-F	1" NPT-F	1" NPT-F	200° F	4.5 lbs.



**YU2121**



**YU5221**

303 Stainless Steel

*Product Group: K*

YU2158	21 GPM	5800 PSI	6500 PSI	(2) 1/2" NPT-F	1/2" NPT-F	(2) 1/2" NPT-F	200° F	4.0 lbs.
--------	--------	----------	----------	----------------	------------	----------------	--------	----------



**YU2158**

## Adjustable Trapped Pressure Unloaders

*Product Group: S*

YVB5K	8 GPM	3200 PSI	3650 PSI	3/8" BSP-M	3/8" BSP-F	3/8" BSP-F	195° F	1.2 lbs.
YVB7K	8 GPM	3200 PSI	3650 PSI	3/8" NPT-M	3/8" NPT-F	3/8" NPT-F	195° F	1.2 lbs.



**YVB5K**

*Includes Panel Mount Feature*

YVB9K	8 GPM	3200 PSI	3650 PSI	3/8" NPT-F	3/8" NPT-F	3/8" NPT-F	195° F	2.0 lbs.
-------	-------	----------	----------	------------	------------	------------	--------	----------



**YVB9K**

## Adjustable Trapped Pressure Unloaders

Product Group: S



YVB8KMS

PULSAR3HPMS



ZKHM



YU5075KMM



YVB3K

	GPM	RATED	MAX	MS AMPS	INLET	OUTLET	BYPASS	MAX TEMP	SHF WGHT
with Microswitch									
YVB8KMS	8.0 GPM	3200 PSI	3650 PSI	5	3/8" BSP-F	3/8" BSP-F	3/8" BSP-F	195° F	2.0 lbs.
YVB8KMS10	8.0 GPM	3200 PSI	3650 PSI	10	3/8" BSP-F	3/8" BSP-F	3/8" BSP-F	195° F	2.0 lbs.
YVB9KMS2	8.0 GPM	3200 PSI	3650 PSI	5	3/8" BSP-F	3/8" BSP-F	(2) 3/8" BSP-F	195° F	2.0 lbs.

Includes Panel Mount Feature

with Microswitch – 5 amp, Stainless Steel Check Valve

YVB9KMSS	8.0 GPM	3200 PSI	3650 PSI	3/8" BSP-F	1/2" BSP-M	3/8" BSP-F	195° F	2.0 lbs.
----------	---------	----------	----------	------------	------------	------------	--------	----------

Includes Panel Mount Feature

With Microswitch, 10 Amp

PULSAR3KMS2	8 GPM	3200 PSI	3650 PSI	3/8" NPT-F	3/8" NPT-F	(2) 3/8" NPT-F	195° F	2.0 lbs.
PULSAR3HPMS	8.0 GPM	3600 PSI	4000 PSI	3/8" NPT-F	3/8" NPT-F	(2) 3/8" NPT-F	195° F	2.0 lbs.

	GPM	MAX	INLET	OUTLET	BYPASS	MAX TEMP	SHF WGHT
--	-----	-----	-------	--------	--------	-------------	-------------

Regulating Unloader

ZKHM	10.8 GPM	3000 PSI	3/8" BSP-F	1/4" BSP-F & 3/8" BSP-M	(2) 3/8" BSP-F	195° F	2.5 lbs.
------	----------	----------	------------	-------------------------	----------------	--------	----------

Regulating Unloader without Spring and Knob with EZ Start

ZKHM1	10.8 GPM	3000 PSI	3/8" BSP-F	1/4" BSP-F & 3/8" BSP-M	(2) 3/8" BSP-F	195° F	2.5 lbs.
-------	----------	----------	------------	-------------------------	----------------	--------	----------

	GPM	RATED	MAX	INLET	OUTLET	BYPASS	MAX TEMP	SHF WGHT
--	-----	-------	-----	-------	--------	--------	-------------	-------------

High Pressure Unloaders with Knob (YU4050K - Black, YU5075K - Red)

YU4050K	10.0 GPM	4050 PSI	4500 PSI	3/8" BSP-M	3/8" BSP-F	1/2" BSP-F	195° F	2.0 lbs.
YU5075K	10.0 GPM	5075 PSI	5650 PSI	3/8" BSP-M	3/8" BSP-F	1/2" BSP-F	195° F	2.0 lbs.
YU5075KS	10.0 GPM	5075 PSI	5650 PSI	3/8" BSP-M	3/8" BSP-F	1/2" BSP-F	195° F	2.0 lbs.

with Microswitch – 5 amp, Stainless Steel Check Valve

YU5075KMS	10.0 GPM	5075 PSI	5650 PSI	3/8" BSP-M	3/8" BSP-F	3/8" BSP-F	195° F	3.0 lbs.
-----------	----------	----------	----------	------------	------------	------------	--------	----------

Premium Pressure-Compensating Unloader min-max setting, Stainless Steel Check Valve, Brass Knob

	GPM	RATED	MAX	INLET	OUTLET	BYPASS	MAX TEMP	SHF WGHT
--	-----	-------	-----	-------	--------	--------	-------------	-------------

YU5075KMM	10.0 GPM	5075 PSI	5650 PSI	3/8" BSP-M	3/8" BSP-F	1/2" BSP-F	195° F	3.0 lbs.
-----------	----------	----------	----------	------------	------------	------------	--------	----------

Trapped Pressure Unloader for the 51 and 60 Series Pumps

	GPM	RATED	MAX	INLET	OUTLET	BYPASS	MAX TEMP	SHF WGHT
--	-----	-------	-----	-------	--------	--------	-------------	-------------

YVB3K	6.5 GPM	3200 PSI	3650 PSI	3/8" BSP-M	3/8" BSP-M	3/8" BSP-M	195° F	1.0 lbs.
YVB3KA	6.5 GPM	3200 PSI	3650 PSI	3/8" NPT-M	3/8" NPT-M	3/8" NPT-M	195° F	1.0 lbs.
YVB3KIT	6.5 GPM	3200 PSI	3650 PSI	1/4" NPT-M	3/8" NPT-M	3/8" NPT-F	195° F	1.0 lbs.

Unloader with Knob and Injector

	GPM	RATED	MAX	INLET	OUTLET	BYPASS	INJECTOR	MAX TEMP	SHF WGHT
--	-----	-------	-----	-------	--------	--------	----------	-------------	-------------

YVB3KIT118	6.5 GPM	3200 PSI	3650 PSI	1/4" NPT-M	3/8" NPT-M	3/8" NPT-F	1.8 mm	195° F	1.25 lbs.
YVB3KIT121	6.5 GPM	3200 PSI	3650 PSI	1/4" NPT-M	3/8" NPT-M	3/8" NPT-F	2.1 mm	195° F	1.25 lbs.
YVB3KIT123	6.5 GPM	3200 PSI	3650 PSI	1/4" NPT-M	3/8" NPT-M	3/8" NPT-F	2.3 mm	195° F	1.25 lbs.

## Modified Pressure Unloaders

Product Group: S

	GPM	RATED	MAX	INLET	OUTLET	HOSE BARB	MAX TEMP	SHP WGHT
YU3678	8 GPM	3200 PSI	3650 PSI	3/8" NPT-F	3/8" NPT-F	3/8" NPT-F	195° F	2.5 lbs.

Includes Panel Mount Feature

### Stainless Steel Check Valve

YU3678MS	8 GPM	3200 PSI	3650 PSI	3/8" NPT-F	1/2" NPT-M	3/8" NPT-F	195° F	2.5 lbs.
----------	-------	----------	----------	------------	------------	------------	--------	----------

Includes Panel Mount Feature



**YU3678**

## Control Set Unloaders

Product Group: S

	GPM	RATED	MAX	INLET	OUTLET	HOSE BARB	MAX TEMP	SHP WGHT
<b>Direct Mount Unloader with Chemical Injector, Pressure Gauge and Filter</b>								
ZOKR1	2.1 GPM	1000 PSI	1000 PSI	3/8" BSP-F	M22	1/4"	165° F	2.0 lbs.

### Direct Mount Unloader with 2 mm Injector

ZKW1	3 GPM	1600 PSI	1600 PSI	3/8" BSP-F	3/8" BSP-M	1/4"	165° F	2.0 lbs.
------	-------	----------	----------	------------	------------	------	--------	----------

### Direct Mount Unloader without Injector

ZKW1SC	3 GPM	1600 PSI	1600 PSI	3/8" BSP-F	3/8" BSP-M	1/4"	165° F	2.0 lbs.
--------	-------	----------	----------	------------	------------	------	--------	----------



**ZKW1**

### New Interpump direct-mount, control-set unloaders, available with or without injectors

ZKW326	2.6 GPM	3000 PSI	3000 PSI	1/2" BSP-F	3/8" BSP-M	1/4"	165° F	2.0 lbs.
ZKW340	4.0 GPM	3000 PSI	3000 PSI	1/2" BSP-F	3/8" BSP-M	1/4"	165° F	2.0 lbs.
ZKW355	5.5 GPM	3000 PSI	3000 PSI	1/2" BSP-F	3/8" BSP-M	1/4"	165° F	2.0 lbs.



**ZKW326**

### Direct Mount Unloader with 2.2 mm Injector

ZKW21	4.5 GPM	3000 PSI	3000 PSI	1/2" BSP-F	3/8" BSP-M	1/4"	200° F	2.0 lbs.
-------	---------	----------	----------	------------	------------	------	--------	----------

### Long body Unloader with 2.2 mm Injector

ZKW21L	4.5 GPM	3000 PSI	3000 PSI	1/2" BSP-F	3/8" BSP-M	1/4"	200° F	2.0 lbs.
--------	---------	----------	----------	------------	------------	------	--------	----------

### Long body Unloader with 2.5 mm Injector

ZKW22L	6.0 GPM	3000 PSI	3000 PSI	1/2" BSP-F	3/8" BSP-M	1/4"	200° F	2.0 lbs.
--------	---------	----------	----------	------------	------------	------	--------	----------

### Long body Unloader without Injector

ZKW2LSC	6.0 GPM	3000 PSI	3000 PSI	1/2" BSP-F	3/8" BSP-M	1/4"	200° F	2.0 lbs.
---------	---------	----------	----------	------------	------------	------	--------	----------

### Unloader with 2.2 mm Injector

ZKW2SC	4.5 GPM	3000 PSI	3000 PSI	1/2" BSP-F	3/8" BSP-M	1/4"	200° F	2.0 lbs.
190043	ZKW2SC with Banjo Fittings							

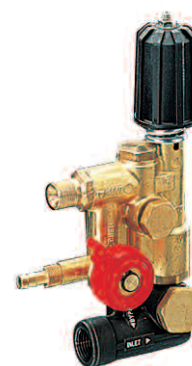

**ZKW21**



**YVB351KDM**



**YVB75KDMN**

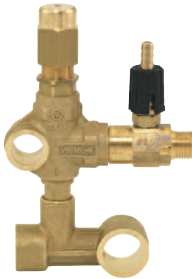

**YVB55KDM**



**ZK50**

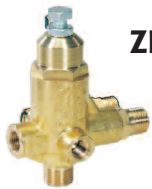

**ZK1**



**ZK9**



**ZK3**

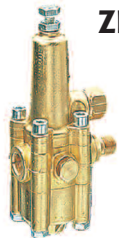

**ZK7**



**PULSARZ**



**NEW!**  
**PULSARZMS**

## Control Set Unloaders

Direct Mount Unloaders for TT/TP Series 51 Pumps

*Product Group: S*

	GPM	RATED	MAX	INLET	OUTLET	INJECTOR	MAX TEMP	SHW WGHT	BOX QTY
YVB351KDM	6.5 GPM	3200 PSI	3650 PSI	3/8" BSP-F	1/4" BSP-F	N/A	195° F	1.8 lbs.	24
YVB351KDMI18	6.5 GPM	3200 PSI	3650 PSI	3/8" BSP-F	1/4" BSP-F	1.8 mm	195° F	1.9 lbs.	20
YVB75KTP	8.0 GPM	3200 PSI	3650 PSI	3/8" BSP-F	3/8" BSP-M	N/A	195° F	1.8 lbs.	20
YVB75KTPF21	8.0 GPM	3200 PSI	3650 PSI	3/8" BSP-F	3/8" BSP-M	2.1 mm	195° F	2.1 lbs.	20

Direct Mount Unloaders for EZ, 47 and 63 Series Pumps

	GPM	RATED	MAX	INLET	OUTLET	HOSE BARB	INJECTOR	MAX TEMP	SHW WGHT	BOX QTY
YVB35KDM	6.5 GPM	3200 PSI	3650 PSI	1/2" BSP-F	3/8" BSP-M	N/A	N/A	195° F	1.5 lbs.	20
YVB35KDMI18	6.5 GPM	3200 PSI	3650 PSI	1/2" BSP-F	3/8" BSP-M	1/4"	1.8 mm	195° F	1.8 lbs.	15
YVB35KDMI21	6.5 GPM	3200 PSI	3650 PSI	1/2" BSP-F	3/8" BSP-M	1/4"	2.1 mm	195° F	1.8 lbs.	15
YVB55KDM	8.0 GPM	3200 PSI	3650 PSI	1/2" BSP-F	3/8" BSP-F	N/A	N/A	195° F	2.0 lbs.	20
YVB55KDMI21	8.0 GPM	3200 PSI	3650 PSI	1/2" BSP-F	3/8" BSP-F	1/4"	2.1 mm	195° F	2.1 lbs.	20
YVB75KDMN	7.8 GPM	3200 PSI	3650 PSI	1/2" BSP-F	3/8" BSP-F	N/A	N/A	195° F	1.8 lbs.	20
YVB75KDMN21	7.8 GPM	3200 PSI	3650 PSI	1/2" BSP-F	3/8" BSP-F	1/4"	2.1 mm	195° F	2.1 lbs.	20
EZ Series Only										
YU4050KDM	10.0 GPM	4050 PSI	4500 PSI	3/8" BSP-F	3/8" BSP-M	N/A	N/A	195° F	3.0 lbs.	10

## Flow Sensitive Unloaders

*Product Group: S*

*Inlet: 3/8" BSP-F*

	GPM	MAXIMUM	OUTLET	BYPASS	MAX TEMP	SHW WGHT	BOX QTY
ZK1	2.3 to 10.8 GPM	3600 PSI	1/2" BSP-M	1/2" BSP-M	165° F	2.3 lbs.	10
ZK138	2.3 to 10.8 GPM	3600 PSI	3/8" BSP-M	1/2" BSP-M	165° F	2.3 lbs.	10

*Inlet: 3/8" BSP-F*

	GPM	MAXIMUM	OUTLET	BYPASS	MAX TEMP	SHW WGHT	BOX QTY
ZK30	2.1 to 3.0 GPM	1500 PSI	3/8" BSP-M	3/4" BSP-M/F	165° F	2.0 lbs.	10
ZK31	3.0 to 4.2 GPM	1500 PSI	3/8" BSP-M	3/4" BSP-M/F	165° F	2.0 lbs.	10
ZK32	4.2 to 5.5 GPM	1500 PSI	3/8" BSP-M	3/4" BSP-M/F	165° F	2.0 lbs.	10
ZK33	5.0 to 6.0 GPM	1500 PSI	3/8" BSP-M	3/4" BSP-M/F	165° F	2.0 lbs.	10
ZK50	2.1 to 3.0 GPM	3000 PSI	3/8" BSP-M	3/4" BSP-M/F	165° F	2.5 lbs.	10
ZK51	3.0 to 4.2 GPM	3000 PSI	3/8" BSP-M	3/4" BSP-M/F	165° F	2.5 lbs.	10
ZK52	4.2 to 6.6 GPM	3000 PSI	3/8" BSP-M	3/4" BSP-M/F	165° F	2.5 lbs.	10
ZK53	6.6 to 10.8 GPM	3000 PSI	3/8" BSP-M	3/4" BSP-M/F	165° F	2.5 lbs.	10

ZK70 (GPV)	2.1 to 3.0 GPM	3500 PSI	3/8" BSP-M	3/8" BSP-F	165° F	5.0 lbs.	5
ZK71 (GPV)	3.0 to 4.2 GPM	3500 PSI	3/8" BSP-M	3/8" BSP-F	165° F	5.0 lbs.	5
ZK72 (GPV)	4.2 to 6.6 GPM	3500 PSI	3/8" BSP-M	3/8" BSP-F	165° F	5.0 lbs.	5
ZK73 (GPV)	6.6 to 10.8 GPM	3500 PSI	3/8" BSP-M	3/8" BSP-F	165° F	5.0 lbs.	5

ZK9	2.5 to 13.2 GPM	5800 PSI	3/8" BSP-M	1/2" BSP-F	165° F	11.0 lbs.	1
-----	-----------------	----------	------------	------------	--------	-----------	---

ZK72 Unloader with #1 Bypass Orifice 190009	4.2 to 6.6 GPM	3000 PSI	3/8" BSP-M	3/8" BSP-F	165° F	5.0 lbs.	5
--	----------------	----------	------------	------------	--------	----------	---

ZK71 Unloader with a #0 Bypass Orifice 190079	3.0 to 4.2 GPM	3000 PSI	3/8" BSP-M	3/8" BSP-F	165° F	5.0 lbs.	5
--	----------------	----------	------------	------------	--------	----------	---

ZK73 Unloader with #2 Bypass Orifice 190361	6.6 to 10.8 GPM	3000 PSI	3/8" BSP-M	3/8" BSP-F	165° F	5.0 lbs.	5
--	-----------------	----------	------------	------------	--------	----------	---

PULSARZ	2.4 to 10.5 GPM	3650 PSI	3/8" NPT-F	3/8" NPT-F (2)	195° F	2.5 lbs.	12
---------	-----------------	----------	------------	----------------	--------	----------	----

PULSARZ with Microswitch - 5 amp PULSARZMS	2.4 to 10.5 GPM	3650 PSI	3/8" NPT-F	3/8" NPT-F (2)	195° F	2.5 lbs.	12
---	-----------------	----------	------------	----------------	--------	----------	----

## Balanced Relief Valves

Product Group: T

	GPM	RATED	MAX	INLET	BYPASS	MAX TEMP	SHW WGHT	BOX QTY
YBRV5325	53 GPM	2600 PSI	2900 PSI	3/4" BSP-F	1/2" BSP-F	195° F	2.0 lbs.	4
YBRV624	6.3 GPM	2200 PSI	2450 PSI	3/8" BSP-F	3/8" BSP-F	195° F	0.8 lbs.	40
YBRV624D	6.3 GPM	2200 PSI	2450 PSI	(2) 3/8" BSP-F	3/8" BSP-F	195° F	1.0 lbs.	40
YBRV631	6.3 GPM	3200 PSI	3650 PSI	3/8" BSP-F	3/8" BSP-F	195° F	0.8 lbs.	40
YBRV631D	6.3 GPM	3200 PSI	3650 PSI	(2) 3/8" BSP-F	3/8" BSP-F	195° F	1.0 lbs.	40
100268	6.3 GPM	300 PSI	N/A	(2) 3/8" BSP-F	3/8" BSP-F	195° F	1.0 lbs.	40
100269	6.3 GPM	300 PSI	N/A	3/8" BSP-F	3/8" BSP-F	195° F	0.8 lbs.	40



**YBRV624D**

## Regulating Valves – Great for Multiple Gun Applications

Product Group: S

	GPM	RATED	INLET	OUTLET	BYPASS	MAX TEMP	SHW WGHT	BOX QTY
ZKHX	4.0 GPM	1900 PSI	3/8" BSP-M	3/8" BSP-M	3/8" BSP-M	165° F	0.6 lbs.	5
ZKSX1	16.0 GPM	3600 PSI	1/2" BSP-M	1/2" BSP-M	-	185° F	2.3 lbs.	1
YVS5100B	6.5 GPM	5600 PSI	3/8" BSP-F	3/8" BSP-F	3/8" BSP-F	195° F	1.0 lbs.	25



**ZKSX1**

## Regulators

Product Group: S

	DESCRIPTION	GPM	RATED	INLET	OUTLET	MAX TEMP	WGHT
100878	Brass	5.0 GPM	2000 PSI	3/8" NPT-F	1/4" NPT-F	190° F	1.3 lbs.
100892	Nickel Plated	5.0 GPM	2000 PSI	3/8" NPT-F	1/4" NPT-F	220° F	1.4 lbs.



**100892**



**100878**



**ZKSR**

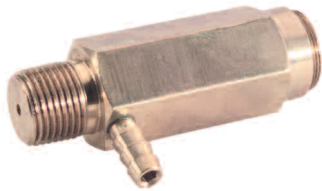

**100722**



**100534**



**YRV2063**



**ZKS3**

**NEW!**



**100971**

## Safety Relief Valves

*Product Group: T*

	<b>GPM</b>	<b>MAX</b>	<b>INLET</b>	<b>OUTLET</b>	<b>MAX TEMP</b>	<b>SHW WGHT</b>
ZKSR	1.3 to 10.8 GPM	3000 PSI	3/8" BSP-M	1/4" BSP-F	165° F	1.5 lbs.
<b>Side Discharge with Hose Barb</b>						
100724	6.0 GPM	6000 PSI	1/4" NPT	Side w/ 1/4" Barb	195° F	1.0 lbs.
100723	6.0 GPM	6000 PSI	3/8" NPT	Side w/ 1/4" Barb	195° F	1.0 lbs.
100722	6.0 GPM	6000 PSI	1/2" NPT	Side w/ 1/4" Barb	195° F	1.0 lbs.
<b>Side Discharge without Hose Barb</b>						
100725	6.0 GPM	6000 PSI	1/4" NPT	Side	195° F	1.0 lbs.
100726	6.0 GPM	6000 PSI	3/8" NPT	Side	195° F	1.0 lbs.
100727	6.0 GPM	6000 PSI	1/2" NPT	Side	195° F	1.0 lbs.
<b>End Discharge</b>						
100728	6.0 GPM	6000 PSI	1/4" NPT	End	195° F	1.0 lbs.
100534	6.0 GPM	6000 PSI	3/8" NPT-M	End	195° F	1.0 lbs.
100729	6.0 GPM	6000 PSI	1/2" NPT	End	195° F	1.0 lbs.
100547	6.0 GPM	6000 PSI	3/8" NPT-M	End 1/8" F	195° F	1.0 lbs.
<b>Preset at 100 PSI Increments (50 piece minimum)</b>						
100547P	6.0 GPM	6000 PSI	3/8" NPT-M	End 1/8" F	195° F	1.0 lbs.
100534P	6.0 GPM	6000 PSI	3/8" NPT-M	End	195° F	1.0 lbs.
100728P	6.0 GPM	6000 PSI	1/4" NPT-M	End	195° F	1.0 lbs.
100723P	6.0 GPM	6000 PSI	3/8" NPT	Side w/ 1/4" Barb	195° F	1.0 lbs.
100726P	6.0 GPM	6000 PSI	3/8" NPT-M	Side	195° F	1.0 lbs.
100722P	6.0 GPM	6000 PSI	1/2" NPT-M	Side w/ 1/4" Barb	195° F	1.0 lbs.
100729P	6.0 GPM	6000 PSI	1/2" NPT-M	End	195° F	1.0 lbs.
<i>All sizes are available preset, please contact General Pump Sales.</i>						
YRV2063	6.3 GPM	2000 PSI	3/8" NPT-M	Side	140° F	1.5 lbs.
YRV3463	6.3 GPM	3500 PSI	3/8" BSP-M	Side	140° F	1.5 lbs.
ZKS3	2.6 to 21.4 GPM	10000 PSI	1/2" BSP-M	Side	284° F	2.0 lbs.

## Hot Water Safety Relief Valves - 303 Stainless

*Product Group: T*

	<b>GPM</b>	<b>MAX</b>	<b>INLET</b>	<b>OUTLET</b>	<b>MAX TEMP</b>	<b>SHW WGHT</b>
100971*	6.0 GPM	6000 PSI	3/8" NPT-M	Side w/ 1/4" Barb	284° F	1.5 lbs.
100972*	6.0 GPM	6000 PSI	1/2" NPT-M	Side w/ 1/4" Barb	284° F	1.5 lbs.

\* Stainless Steel seat and ball

## Pump Thermal Protectors

Product Group: Q

	DESCRIPTION	INLET	HOSE BARB	RELIEF TEMP	SHP WGHT
100556	90° Hose Barb	1/4" NPT	1/4"	145° F	1.5 oz.
100557	90° Hose Barb	3/8" NPT	1/4"	145° F	1.5 oz.
100558	90° Hose Barb	1/2" NPT	1/4"	145° F	1.5 oz.
100844	90° Hose Barb	1/4" BSP-M	1/4"	145° F	1.5 oz.
100845	90° Hose Barb	3/8" BSP-M	1/4"	145° F	1.5 oz.
100846	90° Hose Barb	1/2" BSP-M	1/4"	145° F	1.5 oz.
100677	No Hose Barb	3/8" NPT	N/A	190° F	1.5 oz.
100678	No Hose Barb	1/2" NPT	N/A	190° F	1.5 oz.
100679	90° Hose Barb	3/8" NPT	1/4" SS	190° F	1.5 oz.
100680	90° Hose Barb	1/2" NPT	1/4" SS	190° F	1.5 oz.
100156	90° Hose Barb	3/8" NPT	1/4" SS	145° F	1.5 oz.
100259	Banjo Fitting	3/8" BSP	N/A	145° F	2.5 oz.



100558

**NEW!**



100156

## Easy Start Valves

Product Group: T

	GPM	MAX	INLET	OUTLET	MAX TEMP	SHP WGHT
YESTVALVE	7.8 GPM	3650 PSI	3/8" NPT-M	1/4" Hose Barb	176° F	0.25 lbs.
<i>Provides Easy Start for manual start gas engines</i>						
100323	8.0 GPM	5000 PSI	3/8" NPT-M	1/4" Hose Barb	195° F	0.25 lbs.
100324	8.0 GPM	5000 PSI	1/4" NPT-M	1/4" Hose Barb	195° F	0.25 lbs.
100543	8.0 GPM	5000 PSI	1/4" NPT-M	1/8" NPT-F	195° F	0.25 lbs.
100544	8.0 GPM	5000 PSI	3/8" NPT-M	1/8" NPT-F	195° F	0.25 lbs.
100490	8.0 GPM	5000 PSI	1/2" NPT-M	1/8" NPT-F	195° F	0.25 lbs.
<i>Stainless Steel Seat and Ball</i>						
100970	8.0 GPM	5000 PSI	3/8" NPT-M	1/4" Hose Barb	195° F	0.25 lbs.



YESTVALVE



100324



100543

**NEW!**

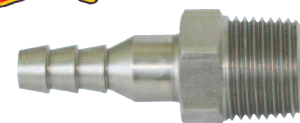

100970





**100325**



**100730**



**YCV34FB**



**YCV12FB**



**Y29092015**



**100814**



**100838**

## Bleeder Valves

*Product Group: T*

	GPM	MAX	INLET	OUTLET	MAX TEMP	SHP WGHT
100325	8.0 GPM	5000 PSI	1/4" NPT-M	1/8" Hose Barb	195° F	0.25 lbs.
100326	8.0 GPM	5000 PSI	3/8" NPT-M	1/8" Hose Barb	195° F	0.25 lbs.
100545	8.0 GPM	5000 PSI	1/4" NPT-M	1/8" NPT-F	195° F	0.25 lbs.
100546	8.0 GPM	5000 PSI	3/8" NPT-M	1/8" NPT-F	195° F	0.25 lbs.

Provides Easy Start function for electric start gas engines.

100676	8.0 GPM	5000 PSI	1/4" NPT-M	1/8" Hose Barb	195° F	0.25 lbs.
100730	8.0 GPM	5000 PSI	1/2" NPT-M	1/8" NPT-F	195° F	0.25 lbs.
100684	8.0 GPM	5000 PSI	3/8" NPT-M	1/8" Hose Barb	195° F	0.25 lbs.

## Check Valves

*Product Group: T*

	DESCRIPTION	GPM	RATED	MAX	INLET	MAX TEMP	SHP WGHT
YCV14FB	Brass	6.5 GPM	2200 PSI	2300 PSI	1/4" BSP-F	195° F	0.5 lbs.
YCV14FSS	Stainless Steel	6.5 GPM	5800 PSI	6500 PSI	1/4" BSP-F	195° F	0.5 lbs.
YCV38FB	Brass	10.5 GPM	2200 PSI	2300 PSI	3/8" BSP-F	195° F	0.5 lbs.
YCV38FSS	Stainless Steel	10.5 GPM	5800 PSI	6500 PSI	3/8" BSP-F	195° F	0.5 lbs.
YCV12FB	Brass	21.0 GPM	2200 PSI	2300 PSI	1/2" BSP-F	195° F	0.5 lbs.
YCV12FSS	Stainless Steel	21.0 GPM	5800 PSI	6500 PSI	1/2" BSP-F	195° F	0.5 lbs.
YCV34FB	Brass	47.6 GPM	2200 PSI	2300 PSI	3/4" BSP-F	195° F	0.8 lbs.
YCV34FSS	Stainless Steel	47.6 GPM	5800 PSI	6500 PSI	3/4" BSP-F	195° F	0.8 lbs.

## Steam Valves

*Product Group: T*

	GPM	RATED	MAX	PANEL FITTING	INLET	OUTLET	MAX TEMP	SHP WGHT
Y29092008	2.3 GPM	3650 PSI	4050 PSI	3/4"	1/4" BSP-M	1/4" BSP-M	175° F	0.3 lbs.
Y29092012	3.4 GPM	3650 PSI	4050 PSI	3/4"	1/4" BSP-M	1/4" BSP-M	175° F	0.3 lbs.
Y29092015	4.0 GPM	3650 PSI	4050 PSI	3/4"	1/4" BSP-M	1/4" BSP-M	175° F	0.3 lbs.

## Needle Valve

*Product Group: D*

	GPM	MAX	INLET	OUTLET	MAX TEMP	SHP WGHT
100814	6.0 GPM	4000 PSI	1/4" NPT-F	1/4" NPT-F	190° F	0.3 lbs.

## Metering Needle Valve

*Adjustable SS Stem allows you to regulate the opening in the bore for fine control of flow.*

	GPM	MAX	INLET	OUTLET	ADJUSTMENT	MAX TEMP	SHP WGHT
100838	6.0 GPM	4000 PSI	1/4" NPT-F	1/4" NPT-F	Side	190° F	0.4 lbs.
100865	6.0 GPM	4000 PSI	1/4" NPT-F	1/4" NPT-F	Bottom	190° F	0.4 lbs.

## Adjustable Chemical Injectors – Brass

Product Group: L

Inlet: 3/8" BSP-M Outlet: 3/8" BSP-M

	ORIFICE	GPM	RATED	MAX TEMP	HOSE BARB	SHP WGHT	BOX QTY
ZROBO0	2.0 mm	2.1 to 2.9 GPM	3200 PSI	210° F	1/4"	0.8 lbs.	25
ZROBO1	2.2 mm	2.9 to 4.0 GPM	3200 PSI	210° F	1/4"	0.8 lbs.	25
ZROBO2	2.5 mm	4.0 to 5.6 GPM	3200 PSI	210° F	1/4"	0.8 lbs.	25
ZROBO3	2.75 mm	6.6 to 10.8 GPM	3200 PSI	210° F	1/4"	0.8 lbs.	25

Chemical Injectors with Brass Knob

ZROBO0B	2.0 mm	2.1 to 2.9 GPM	3200 PSI	210° F	1/4"	0.8 lbs.	25
ZROBO1B	2.2 mm	2.9 to 4.0 GPM	3200 PSI	210° F	1/4"	0.8 lbs.	25
ZROBO2B	2.5 mm	4.0 to 5.6 GPM	3200 PSI	210° F	1/4"	0.8 lbs.	25
ZROBO3B	2.75 mm	6.6 to 10.8 GPM	3200 PSI	210° F	1/4"	0.8 lbs.	25

EPDM O-Ring

	ORIFICE	GPM	RATED	INLET	OUTLET	MAX TEMP	HOSE BARB	SHP WGHT
YAINJ18E	1.8 mm	2.0 to 2.6 GPM	4000 PSI	3/8" NPT-M	3/8" NPT-M	195° F	1/4"	0.4 lbs.
YAINJ21E	2.1 mm	2.6 to 4.0 GPM	4000 PSI	3/8" NPT-M	3/8" NPT-M	195° F	1/4"	0.4 lbs.
YAINJ23E	2.3 mm	4.0 to 5.3 GPM	4000 PSI	3/8" NPT-M	3/8" NPT-M	195° F	1/4"	0.4 lbs.

## Standard Adjustable Chemical Injector

Product Group: L

	ORIFICE	GPM	MAX	INLET/OUTLET	MAX TEMP	HOSE BARB	SHP WGHT
100823	1.5 mm	1.0 to 2.0 GPM	4250 PSI	3/8" NPT-M	190° F	1/4"	0.3 lbs.
100824	1.8 mm	2.0 to 3.0 GPM	4250 PSI	3/8" NPT-M	190° F	1/4"	0.3 lbs.
100825	2.1 mm	3.0 to 5.0 GPM	4250 PSI	3/8" NPT-M	190° F	1/4"	0.3 lbs.
100826	2.3 mm	5.0 to 8.0 GPM	4250 PSI	3/8" NPT-M	190° F	1/4"	0.3 lbs.

## Adjustable Chemical Injectors – Stainless Steel

	ORIFICE	GPM	RATED	INLET	OUTLET	MAX TEMP	HOSE BARB	SHP WGHT
100861	1.8 mm	2.0 to 3.0 GPM	5500 PSI	3/8" NPT-M	3/8" NPT-M	190° F	1/4"	0.5 lbs.
100862	2.1 mm	3.0 to 5.0 GPM	5500 PSI	3/8" NPT-M	3/8" NPT-M	190° F	1/4"	0.5 lbs.
100863	2.3 mm	5.0 to 8.0 GPM	5500 PSI	3/8" NPT-M	3/8" NPT-M	190° F	1/4"	0.5 lbs.

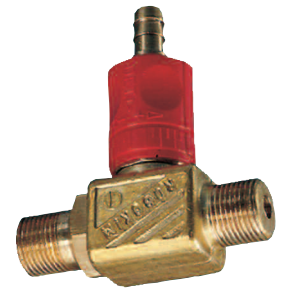

**ZROBO**



**YAINJ18E**



**100823**



**100861**



**100810**

## High Draw Adjustable Chemical Injectors

*Product Group: L*

*Chemical draw up to 20%*

	ORIFICE	GPM	RATED	INLET	OUTLET	MAX TEMP	HOSE BARB	SHP WGHT
100810	1.5 mm	1.0 to 2.0 GPM	4500 PSI	3/8" NPT-M	3/8" NPT-M	195° F	1/4"	0.3 lbs.
100811	1.8 mm	2.0 to 3.0 GPM	4500 PSI	3/8" NPT-M	3/8" NPT-M	195° F	1/4"	0.3 lbs.
100812	2.1 mm	3.0 to 5.0 GPM	4500 PSI	3/8" NPT-M	3/8" NPT-M	195° F	1/4"	0.3 lbs.
100813	2.3 mm	5.0 to 8.0 GPM	4500 PSI	3/8" NPT-M	3/8" NPT-M	195° F	1/4"	0.3 lbs.



**100575**

## High Draw Adjustable Chemical Injectors with Acid Kit

*Product Group: L*

	ORIFICE	GPM	RATED	INLET	OUTLET	MAX TEMP	HOSE BARB	SHP WGHT
100827	1.5 mm	1.0 to 2.0 GPM	4500 PSI	3/8" NPT-M	3/8" NPT-M	190° F	1/4"	0.3 lbs.
100828	1.8 mm	2.0 to 3.0 GPM	4500 PSI	3/8" NPT-M	3/8" NPT-M	190° F	1/4"	0.3 lbs.
100829	2.1 mm	3.0 to 5.0 GPM	4500 PSI	3/8" NPT-M	3/8" NPT-M	190° F	1/4"	0.3 lbs.
100830	2.3 mm	5.0 to 8.0 GPM	4500 PSI	3/8" NPT-M	3/8" NPT-M	190° F	1/4"	0.3 lbs.



**100633**

## Quick Connect Adjustable Chemical Injectors – Brass

*Product Group: L*

	ORIFICE	GPM	MAX	INLET	OUTLET	MAX TEMP	HOSE BARB	SHP WGHT
100575	1.8 mm	2.0 to 3.0 GPM	3500 PSI	3/8" M Plug	3/8" F Coupler	190° F	1/4"	0.4 lbs.
100576	2.1 mm	3.0 to 5.0 GPM	3500 PSI	3/8" M Plug	3/8" F Coupler	190° F	1/4"	0.4 lbs.
100577	2.3 mm	5.0 to 8.0 GPM	3500 PSI	3/8" M Plug	3/8" F Coupler	190° F	1/4"	0.4 lbs.
100617	1.8 mm	2.0 to 3.0 GPM	3500 PSI	3/8" F Coupler	3/8" M Plug	190° F	1/4"	0.4 lbs.
100618	2.1 mm	3.0 to 5.0 GPM	3500 PSI	3/8" F Coupler	3/8" M Plug	190° F	1/4"	0.4 lbs.
100619	2.3 mm	5.0 to 8.0 GPM	3500 PSI	3/8" F Coupler	3/8" M Plug	190° F	1/4"	0.4 lbs.



**100654**

## Quick Connect Adjustable Chemical Injectors – Stainless Steel Plug

*Product Group: L*

	ORIFICE	GPM	MAX	INLET	OUTLET	MAX TEMP	HOSE BARB	SHP WGHT
100633	1.8 mm	2.0 to 3.0 GPM	3500 PSI	3/8" F Coupler	3/8" M Plug	190° F	1/4"	0.4 lbs.
100634	2.1 mm	3.0 to 5.0 GPM	3500 PSI	3/8" F Coupler	3/8" M Plug	190° F	1/4"	0.4 lbs.
100635	2.3 mm	5.0 to 8.0 GPM	3500 PSI	3/8" F Coupler	3/8" M Plug	190° F	1/4"	0.4 lbs.

	ORIFICE	GPM	MAX	INLET	OUTLET	MAX TEMP	HOSE BARB	SHP WGHT
100653	1.8 mm	2.0 to 3.0 GPM	3500 PSI	3/8" M Plug	3/8" F Coupler	190° F	1/4"	0.4 lbs.
100654	2.1 mm	3.0 to 5.0 GPM	3500 PSI	3/8" M Plug	3/8" F Coupler	190° F	1/4"	0.4 lbs.
100655	2.3 mm	5.0 to 8.0 GPM	3500 PSI	3/8" M Plug	3/8" F Coupler	190° F	1/4"	0.4 lbs.

## Quick Connect Adjustable Chemical Injectors – Stainless Steel Plug and Collar

Product Group: L

	ORIFICE	GPM	MAX	INLET	OUTLET	MAX TEMP	HOSE BARB	SHP WGHT
100763	1.8 mm	2.0 to 3.0 GPM	4500 PSI	3/8" M Plug	3/8" F Coupler	190° F	1/4"	0.4 lbs.
100764	2.1 mm	3.0 to 5.0 GPM	4500 PSI	3/8" M Plug	3/8" F Coupler	190° F	1/4"	0.4 lbs.
100765	2.3 mm	5.0 to 8.0 GPM	4500 PSI	3/8" M Plug	3/8" F Coupler	190° F	1/4"	0.4 lbs.



**100764**

## Standard Fixed Chemical Injector

Product Group: L

	ORIFICE	GPM	MAX	INLET/OUTLET	MAX TEMP	HOSE BARB	SHP WGHT
100819	1.5 mm	1.0 to 2.0 GPM	4250 PSI	3/8" NPT-M	190° F	1/4"	0.3 lbs.
100820	1.8 mm	2.0 to 3.0 GPM	4250 PSI	3/8" NPT-M	190° F	1/4"	0.3 lbs.
100821	2.1 mm	3.0 to 5.0 GPM	4250 PSI	3/8" NPT-M	190° F	1/4"	0.3 lbs.
100822	2.3 mm	5.0 to 8.0 GPM	4250 PSI	3/8" NPT-M	190° F	1/4"	0.3 lbs.



**100821**

## Fixed Chemical Injectors – Stainless Steel

Product Group: L

	ORIFICE	GPM	RATED	INLET	OUTLET	MAX TEMP	HOSE BARB	SHP WGHT
100873	1.8 mm	2.0 to 3.0 GPM	5500 PSI	3/8" NPT-M	3/8" NPT-M	190° F	1/4"	0.4 lbs.
100874	2.1 mm	3.0 to 5.0 GPM	5500 PSI	3/8" NPT-M	3/8" NPT-M	190° F	1/4"	0.4 lbs.
100875	2.3 mm	5.0 to 8.0 GPM	5500 PSI	3/8" NPT-M	3/8" NPT-M	190° F	1/4"	0.4 lbs.



**100873**

	ORIFICE	GPM	MAX	INLET	OUTLET	MAX TEMP	HOSE BARB	SHP WGHT
100336	1.44 mm	1.0 to 2.0 GPM	5500 PSI	3/8" NPT-M	3/8" NPT-M	190° F	1/4"	0.4 lbs.
100094	1.6 mm	2.0 to 3.0 GPM	5500 PSI	3/8" NPT-M	3/8" NPT-M	190° F	1/4"	0.4 lbs.
100835	1.8 mm	2.0 to 3.0 GPM	5500 PSI	3/8" NPT-M	3/8" NPT-M	190° F	1/4"	0.4 lbs.
100334	2.1 mm	2.0 to 4.0 GPM	5500 PSI	3/8" NPT-M	3/8" NPT-M	190° F	1/4"	0.4 lbs.
100333	2.2 mm	3.0 to 5.0 GPM	5500 PSI	3/8" NPT-M	3/8" NPT-M	190° F	1/4"	0.4 lbs.
100339	2.5 mm	5.0 to 8.0 GPM	5500 PSI	3/8" NPT-M	3/8" NPT-M	190° F	1/4"	0.4 lbs.

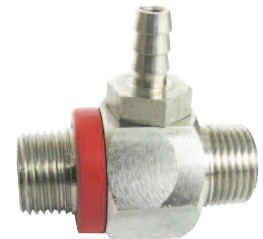

**100336**

## High Draw Fixed Chemical Injectors

Product Group: L

Chemical draw up to 20%

	ORIFICE	GPM	MAX	INLET	OUTLET	MAX TEMP	HOSE BARB	SHP WGHT
100773	1.5 mm	1.0 to 2.0 GPM	4500 PSI	3/8" NPT-M	3/8" NPT-M	190° F	1/4"	0.3 lbs.
100774	1.8 mm	2.0 to 3.0 GPM	4500 PSI	3/8" NPT-M	3/8" NPT-M	190° F	1/4"	0.3 lbs.
100775	2.1 mm	3.0 to 5.0 GPM	4500 PSI	3/8" NPT-M	3/8" NPT-M	190° F	1/4"	0.3 lbs.
100776	2.3 mm	5.0 to 8.0 GPM	4500 PSI	3/8" NPT-M	3/8" NPT-M	190° F	1/4"	0.3 lbs.



**100775**



**100790**

## High Draw Fixed Chemical Injectors w/Acid Kit

*Product Group: L*

	ORIFICE	GPM	MAX	INLET	OUTLET	MAX TEMP	HOSE BARB	SHW WGHT
100947	1.5 mm	1.0 to 2.0 GPM	4500 PSI	3/8" NPT-M	3/8" NPT-M	190° F	1/4"	0.3 lbs.
100948	1.8 mm	2.0 to 3.0 GPM	4500 PSI	3/8" NPT-M	3/8" NPT-M	190° F	1/4"	0.3 lbs.
100949	2.1 mm	3.0 to 5.0 GPM	4500 PSI	3/8" NPT-M	3/8" NPT-M	190° F	1/4"	0.3 lbs.
100950	2.3 mm	5.0 to 8.0 GPM	4500 PSI	3/8" NPT-M	3/8" NPT-M	190° F	1/4"	0.3 lbs.

## High Draw Dual Port Chemical Injectors

*Product Group: L*

	ORIFICE	GPM	MAX	INLET	OUTLET	MAX TEMP	HOSE BARB	SHW WGHT
100790	2.1 mm	3.0 to 5.0 GPM	4500 PSI	3/8" NPT-M	3/8" NPT-M	190° F	1/4"	0.4 lbs.
100791	2.3 mm	5.0 to 8.0 GPM	4500 PSI	3/8" NPT-M	3/8" NPT-M	190° F	1/4"	0.4 lbs.

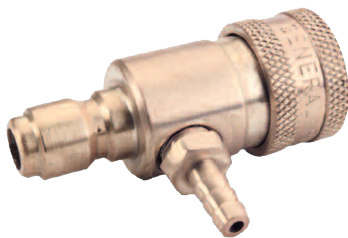

**100570**

## Quick Connect Fixed Chemical Injectors – Brass

*Product Group: L*

	ORIFICE	GPM	MAX	INLET	OUTLET	MAX TEMP	HOSE BARB	SHW WGHT
100570	1.8 mm	2.0 to 3.0 GPM	3500 PSI	3/8" M Plug	3/8" F Coupler	190° F	1/4"	0.4 lbs.
100571	2.1 mm	3.0 to 5.0 GPM	3500 PSI	3/8" M Plug	3/8" F Coupler	190° F	1/4"	0.4 lbs.
100572	2.3 mm	5.0 to 8.0 GPM	3500 PSI	3/8" M Plug	3/8" F Coupler	190° F	1/4"	0.4 lbs.
100594	1.8 mm	2.0 to 3.0 GPM	3500 PSI	3/8" F Coupler	3/8" M Plug	190° F	1/4"	0.4 lbs.
100595	2.1 mm	3.0 to 5.0 GPM	3500 PSI	3/8" F Coupler	3/8" M Plug	190° F	1/4"	0.4 lbs.
100616	2.3 mm	5.0 to 8.0 GPM	3500 PSI	3/8" F Coupler	3/8" M Plug	190° F	1/4"	0.4 lbs.



**100630**

## Quick Connect Fixed Chemical Injectors with Stainless Steel Plug

*Product Group: L*

	ORIFICE	GPM	MAX	INLET	OUTLET	MAX TEMP	HOSE BARB	SHW WGHT
100690	1.5 mm	1.0 to 2.0 GPM	3500 PSI	3/8" F Coupler	3/8" M Plug	190° F	1/4"	0.4 lbs.
100630	1.8 mm	2.0 to 3.0 GPM	3500 PSI	3/8" F Coupler	3/8" M Plug	190° F	1/4"	0.4 lbs.
100631	2.1 mm	3.0 to 5.0 GPM	3500 PSI	3/8" F Coupler	3/8" M Plug	190° F	1/4"	0.4 lbs.
100632	2.3 mm	5.0 to 8.0 GPM	3500 PSI	3/8" F Coupler	3/8" M Plug	190° F	1/4"	0.4 lbs.

## Quick Connect Fixed Chemical Injectors with Stainless Steel Plug

*Product Group: L*

	ORIFICE	GPM	MAX	INLET	OUTLET	MAX TEMP	HOSE BARB	SHW WGHT
100636	1.8 mm	2.0 to 3.0 GPM	3500 PSI	3/8" M Plug	3/8" F Coupler	190° F	1/4"	0.4 lbs.
100637	2.1 mm	3.0 to 5.0 GPM	3500 PSI	3/8" M Plug	3/8" F Coupler	190° F	1/4"	0.4 lbs.
100638	2.3 mm	5.0 to 8.0 GPM	3500 PSI	3/8" M Plug	3/8" F Coupler	190° F	1/4"	0.4 lbs.



**100636**

## Dual Port Injector

Product Group: L

	ORIFICE	GPM	MAX	INLET	OUTLET	MAX TEMP	HOSE BARB	SHP WGHT
100541	2.1 mm	3.0 to 5.0 GPM	5500 PSI	3/8" NPT-M	3/8" NPT-M	190° F	1/4"	0.5 lbs.

100541



## Pulse Pump

Product Group: S

	GPM	RATED	INLET	OUTLET	MAX TEMP	SHP WGHT
100906	0.75 GPM	1500 PSI	1/8" NPT-F	1/8" NPT-F	190° F	1.5 lbs.

Adapter fittings for pulse pump

SERIES	FITTING	VALVE
60 (TC, HTC)	520222	103036
47 (HTS)	520190	103035
44 (EZ)	520197	103036
63 (TX, (HTX)	520197	103036
66 (HTF)	520223	103090

100906



## Pulse Pump with Ball Valve (3000 PSI)

Product Group: S

	GPM	RATED	INLET	OUTLET	MAX TEMP	SHP WGHT
100152	0.75 GPM	1500 PSI	1/8" NPT-F	1/8" NPT-F	190° F	1.5 lbs.

Adapter fittings for pulse pump

SERIES	FITTING	VALVE
60 (TC, HTC)	520275	103036
47 (HTS)	520274	103035
44 (EZ)	520273	103036
63 (TX, (HTX)	520273	103036
66 (HTF)	520276	103090



100152

## Chemical Valves

Product Group: T

	DESCRIPTION	GPM	RATED	CONNECTIONS	MAX TEMP	HOSE BARB	SHP WGHT
Y29095400	90° Elbow	2.6 GPM	400 PSI	1/4" BSP-M	105° F	1/4"	0.5 lbs.
Y29094500	Straight	2.6 GPM	400 PSI	1/4" BSP-M	105° F	1/4"	0.4 lbs.

Y29095400

Y29094500



## High Pressure Soap Shooter

Product Group: L

Attaches to a QC on lance or extension wand, can shoot soap up to 3 stories! Includes 30 foot hose, filter and nozzle.

	NOZZLE SIZE
100145	#4.0
100146	#4.5
100147	#5.0



100145

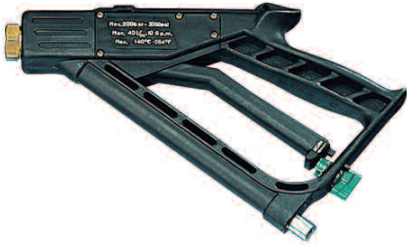

**ZGPIM**

## Front Entry Spray Gun

Product Group: I

	GPM	RATED	MAX	INLET	OUTLET	MAX TEMP	SHW	WGHT
ZGPIM	10.5 GPM	3000 PSI	3000 PSI	1/4" BSP-M	1/4" BSP-F	284° F		2.0 lbs.
YRL20	8.0 GPM	2900 PSI	3200 PSI	3/8" BSP-F	1/4" BSP-F	320° F		0.8 lbs.
ZGP11	10.5 GPM	3000 PSI	3000 PSI	3/8" BSP-F	1/4" BSP-F	285° F		1.2 lbs.



**YG4000S**

## Rear Entry Spray Gun

Product Group: I

	DESCRIPTION	GPM	RATED	MAX	INLET	OUTLET	MAX TEMP	SHW	WGHT	BOX QTY
YG4000S	Straight	10.5 GPM	3650 PSI	4050 PSI	3/8" NPT-F	1/4" NPT-F	300° F	1.2 lbs.		20



**YRL2640W**

YRL2640		8.0 GPM	3650 PSI	4000 PSI	3/8" NPT-F	1/4" NPT-F	320° F	1.0 lbs.		20
YRL2640W	Weep Seat	8.0 GPM	3650 PSI	4000 PSI	3/8" NPT-F	1/4" NPT-F	320° F	1.0 lbs.		20
YG3600		9.0 GPM	3200 PSI	3650 PSI	3/8" NPT-F	1/4" NPT-F	320° F	1.2 lbs.		15
YG3600W	Weep Seat	9.0 GPM	3200 PSI	3650 PSI	3/8" NPT-F	1/4" NPT-F	320° F	1.2 lbs.		15

YG5000		10.0 GPM	5000 PSI	5000 PSI	3/8" NPT-F	1/4" NPT-F	320° F	1.2 lbs.		20
YG5000W	Weep Seat	10.0 GPM	5000 PSI	5000 PSI	3/8" NPT-F	1/4" NPT-F	320° F	1.2 lbs.		20

### Chlorine Applications

YG5000C	Ceramic Ball	10.0 GPM	5000 PSI	5000 PSI	3/8" NPT-F	1/4" NPT-F	320° F	1.2 lbs.		20
---------	--------------	----------	----------	----------	------------	------------	--------	----------	--	----

YG4010		10.5 GPM	4500 PSI	5000 PSI	3/8" NPT-F	1/4" NPT-F	320° F	1.2 lbs.		15
YG4010W	Weep Seat	10.5 GPM	4500 PSI	5000 PSI	3/8" NPT-F	1/4" NPT-F	320° F	1.2 lbs.		11

YG4000		10.0 GPM	4500 PSI	5000 PSI	3/8" NPT-F	1/4" NPT-F	320° F	1.8 lbs.		40
YG4000W	Weep Seat	10.5 GPM	3650 PSI	4050 PSI	3/8" NPT-F	1/4" NPT-F	320° F	1.8 lbs.		40

**YG5000**

## Rear Entry Spray Gun

Product Group: I

	DESCRIPTION	GPM	RATED	MAX	INLET	OUTLET	MAX TEMP	SHP WGHT	BOX QTY
DG4000		8.0 GPM	4000 PSI	4000 PSI	3/8" NPT-F	1/4" NPT-F	320° F	1.1 lbs.	20
DG5010		10.0 GPM	5000 PSI	5000 PSI	3/8" NPT-F	1/4" NPT-F	320° F	1.4 lbs.	20
DG5010W	Weep Seat	10.0 GPM	5000 PSI	5000 PSI	3/8" NPT-F	1/4" NPT-F	320° F	1.4 lbs.	20



**DG5010**

DCG5010	Compensating	10.0 GPM	5000 PSI	5000 PSI	3/8" NPT-F	1/4" NPT-F	320° F	1.4 lbs.	20
---------	--------------	----------	----------	----------	------------	------------	--------	----------	----



**DCG5010**

YRL51	Compensating	13.2 GPM	3650 PSI	4050 PSI	3/8" NPT-F	1/4" NPT-F	320° F	1.5 lbs.	8
-------	--------------	----------	----------	----------	------------	------------	--------	----------	---



**YRL51**

YRL56	Compensating	8.0 GPM	5100 PSI	5650 PSI	3/8" NPT-F	1/4" NPT-F	320° F	1.5 lbs.	8
-------	--------------	---------	----------	----------	------------	------------	--------	----------	---



**YRL56**

## High Flow Rear Entry Wash Down Gun

Product Group: I

	DESCRIPTION	GPM	RATED	MAX	INLET	OUTLET	MAX TEMP	SHP WGHT	BOX QTY
YG1635	Wash Down	16.0 GPM	350 PSI	350 PSI	1/2" BSP-F	Adj. Cone Nozzle	195° F	2.1 lbs.	10
YG1635S	Wash Down	16.0 GPM	350 PSI	350 PSI	1/2" BSP-F	Adj. Cone Nozzle	195° F	2.1 lbs.	10
(w/swivel)									
YG1635SS	Wash Down	16.0 GPM	350 PSI	350 PSI	1/2" BSP-F	Adj. Cone Nozzle	195° F	2.1 lbs.	10
(316SS)									



**YG1635**



# GUNS & LANCES



**YG4060SS**



**YG1732**



**YG2953B**



**YG5200**

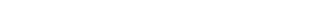

## Rear Entry Spray Gun – Stainless Steel

*Product Group: I*

	DESCRIPTION	GPM	RATED	MAX	INLET	OUTLET	MAX TEMP	SHW WGHT	BOX QTY
YG4060SS		10.5 GPM	3650 PSI	4050 PSI	3/8" NPT-F	1/4" NPT-F	320° F	2.0 lbs.	2
YG1732	Cartridge	32 GPM	1740 PSI	1950 PSI	1/2" BSP-F	1/2" BSP-F	320° F	4.0 lbs.	20
YG2953B	Cartridge	53 GPM	2900 PSI	3200 PSI	3/4" BSP-F	1/2" BSP-F	210° F	5.0 lbs.	10
YG5200	Compensating	10.5 GPM	5800 PSI	6400 PSI	3/8" NPT-F	1/4" NPT-F	320° F	2.0 lbs.	20
YG5200/L42	YG5200 with 42" Stainless Steel Lance								

## Spray Gun with Lance

*Product Group: I*



**Y30256717**

	DESCRIPTION	GPM	RATED	MAX	INLET	OUTLET	MAX TEMP	SHW WGHT
YRL56L	42" Lance	8.0 GPM	5100 PSI	5650 PSI	3/8" NPT-F	1/4" NPT-F	320° F	3.3 lbs.
YG3000DS	16" Lance	10.5 GPM	2750 PSI	3050 PSI	3/8" NPT-F	1/8" NPT-F	140° F	2.5 lbs.
YG3000D	40" Lance	10.5 GPM	2750 PSI	3050 PSI	3/8" NPT-F	1/8" NPT-F	140° F	3.0 lbs.
Y30256717	YG5000 assembled with 36" S3 Lance and 1/4" Quick Disconnect							
100751	YG5000 assembled with 18" Lance and 1/4" Quick Disconnect							
100059	YG4010 assembled with 36" Insulated Lance and 1/4" Quick Disconnect							

## Stainless Steel Lance

Product Group: I

	LENGTH	GPM	RATED	MAX	INLET	OUTLET	SHP WGHT	BOX QTY
YL8SS	8"	10.5 GPM	3650 PSI	4050 PSI	1/4" NPT-M	1/4" NPT-M	0.5 lbs.	200
YL31SS	31"	10.5 GPM	3650 PSI	4050 PSI	1/4" NPT-M	1/4" NPT-M	0.7 lbs.	100
YL40SS	40"	10.5 GPM	3650 PSI	4050 PSI	1/4" NPT-M	1/4" NPT-M	1.0 lbs.	100
YL72SS	72"	10.5 GPM	3650 PSI	4050 PSI	1/4" NPT-M	1/4" NPT-M	1.8 lbs.	50

## Straight-Insulated Lance

Product Group: I

	LENGTH	GPM	RATED	MAX	INLET	OUTLET	MAX TEMP	SHP WGHT	BOX QTY
YL20PNS	20"	10.5 GPM	3650 PSI	4050 PSI	1/4" NPT-M	1/4" NPT-F	320° F	1.1 lbs.	25
YL24PNS	24"	10.5 GPM	3650 PSI	4050 PSI	1/4" NPT-M	1/4" NPT-F	320° F	1.3 lbs.	25
YL27PNS	27"	10.5 GPM	3650 PSI	4050 PSI	1/4" NPT-M	1/4" NPT-F	320° F	1.4 lbs.	25
YL35PNS	35"	10.5 GPM	3650 PSI	4050 PSI	1/4" NPT-M	1/4" NPT-F	320° F	1.7 lbs.	25
YL47PNS	47"	10.5 GPM	3650 PSI	4050 PSI	1/4" NPT-M	1/4" NPT-F	320° F	2.2 lbs.	25
YL59PNS	59"	10.5 GPM	3650 PSI	4050 PSI	1/4" NPT-M	1/4" NPT-F	320° F	2.8 lbs.	10
YL67PNS	67"	10.5 GPM	3650 PSI	4050 PSI	1/4" NPT-M	1/4" NPT-F	320° F	3.0 lbs.	10
YL79PNS	79"	10.5 GPM	3650 PSI	4050 PSI	1/4" NPT-M	1/4" NPT-F	320° F	3.4 lbs.	10

## Bent-Insulated Lance

Product Group: I

	LENGTH	GPM	RATED	MAX	INLET	OUTLET	MAX TEMP	SHP WGHT	BOX QTY
YL36B	Vented 36"	10.5 GPM	3650 PSI	4050 PSI	1/4" NPT-M	1/4" NPT-F	320° F	1.7 lbs.	20
YL20PNB	20"	10.5 GPM	3650 PSI	4050 PSI	1/4" NPT-M	1/4" NPT-F	320° F	1.1 lbs.	25
YL24PNB	24"	10.5 GPM	3650 PSI	4050 PSI	1/4" NPT-M	1/4" NPT-F	320° F	1.3 lbs.	25
YL27PNB	27"	10.5 GPM	3650 PSI	4050 PSI	1/4" NPT-M	1/4" NPT-F	320° F	1.4 lbs.	25
YL35PNB	35"	10.5 GPM	3650 PSI	4050 PSI	1/4" NPT-M	1/4" NPT-F	320° F	1.7 lbs.	25
YL47PNB	47"	10.5 GPM	3650 PSI	4050 PSI	1/4" NPT-M	1/4" NPT-F	320° F	2.2 lbs.	25
YL59PNB	59"	10.5 GPM	3650 PSI	4050 PSI	1/4" NPT-M	1/4" NPT-F	320° F	2.8 lbs.	10
YL67PNB	67"	10.5 GPM	3650 PSI	4050 PSI	1/4" NPT-M	1/4" NPT-F	320° F	3.0 lbs.	10
YL79PNB	79"	10.5 GPM	3650 PSI	4050 PSI	1/4" NPT-M	1/4" NPT-F	320° F	3.0 lbs.	10
ZZ15	59" Zinc Lance	10.5 GPM	3000 PSI		1/4" BSP-M	1/4" BSP-F	284° F	2.5 lbs.	

## Chrome-Plated Insulated Lances

Product Group: I

	LENGTH	GPM	RATED	INLET	OUTLET	MAX TEMP	SHP WGHT
DL24ICS	24"	10.0 GPM	4000 PSI	1/4" NPT-M	1/4" NPT-M	220° F	1.3 lbs.
DL27ICS	27"	10.0 GPM	4000 PSI	1/4" NPT-M	1/4" NPT-M	220° F	1.4 lbs.
DL36ICS	36"	10.0 GPM	4000 PSI	1/4" NPT-M	1/4" NPT-M	220° F	1.7 lbs.
DL42ICS	42"	10.0 GPM	4000 PSI	1/4" NPT-M	1/4" NPT-M	220° F	1.7 lbs.
DL47ICS	47"	10.0 GPM	4000 PSI	1/4" NPT-M	1/4" NPT-M	220° F	2.2 lbs.
DL59ICS	59"	10.0 GPM	4000 PSI	1/4" NPT-M	1/4" NPT-M	220° F	2.8 lbs.
DL79ICS	79"	10.0 GPM	4000 PSI	1/4" NPT-M	1/4" NPT-M	220° F	3.4 lbs.

## Vented Chrome-Plated Lances

	LENGTH	GPM	RATED	INLET	OUTLET	MAX TEMP	SHP WGHT
DL36VCS	36"	10.0 GPM	4000 PSI	1/4" NPT-M	1/4" NPT-M	320° F	1.7 lbs.
DL48VCS	48"	10.0 GPM	4000 PSI	1/4" NPT-M	1/4" NPT-M	320° F	2.2 lbs.

## Vented Stainless Steel Lance

	LENGTH	GPM	RATED	INLET	OUTLET	MAX TEMP	SHP WGHT
DL36VSSB	36"	10.0 GPM	4000 PSI	1/4" NPT-M	1/4" NPT-M	320° F	1.7 lbs.



YL8SS



YL20PNS

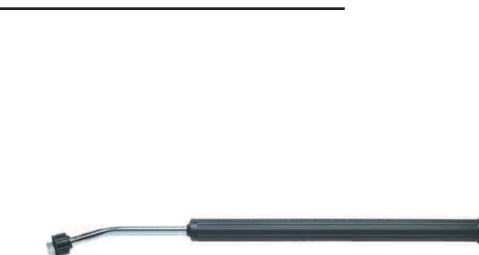

YL20PNB



DL241CS



DL36VCS



DL36VSSB



**YDL33**

## Stainless Steel, Insulated Handle, Straight Double Lance

*Product Group: I*

	LENGTH	GPM	RATED	MAX	INLET	OUTLET	MAX TEMP	SHW WT	BOX QTY
YDL33	33"	10.5 GPM	3650 PSI	4050 PSI	1/4" NPT-M	1/4" NPT-M	320° F	2.2 lbs.	20
YDL41	41"	10.5 GPM	3650 PSI	4050 PSI	1/4" NPT-M	1/4" NPT-M	320° F	2.4 lbs.	20
YDL41SS	41"	10.5 GPM	3650 PSI	4050 PSI	1/4" NPT-M	1/4" NPT-M	320° F	2.4 lbs.	10
YDL33SSB	33"	10.5 GPM	3650 PSI	4050 PSI	1/4" NPT-M	1/4" NPT-M	320° F	2.2 lbs.	20
YDL41SSB	41"	10.5 GPM	3650 PSI	4050 PSI	1/4" NPT-M	1/4" NPT-M	320° F	2.4 lbs.	20

## Zinc-Plated Steel, Bent Double Lance

*Product Group: I*

	LENGTH	GPM	RATED	MAX	INLET	OUTLET	MAX TEMP	SHW WT	BOX QTY
YDL33B	33"	10.5 GPM	3650 PSI	4050 PSI	1/4" NPT-M	1/4" NPT-M	320° F	2.2 lbs.	20
YDL41B	41"	10.5 GPM	3650 PSI	4050 PSI	1/4" NPT-M	1/4" NPT-M	320° F	2.4 lbs.	20
ZZDBL	36"	10.5 GPM	3000 PSI	3000 PSI	1/4" BSP-M	1/4" BSP-F	284° F	2.5 lbs.	50
100673	ZZDBL Lance assembly with 1/4" QD connector and 965400M nozzle								
ZZDBL72	72"	10.5 GPM	3000 PSI	3000 PSI	1/4" BSP-M	1/4" BSP-F	284° F	3.5 lbs.	50
100752	ZZDBL72 Lance assembly with 1/4" QD connector and 965400M nozzle								

## Rectangular Handle – Vented Grip

*Product Group: I*

	LENGTH	GPM	RATED	MAXIMUM	INLET	OUTLET	MAX TEMP	SHW WT	BOX QTY
YDL935	35"	10.5 GPM	3650 PSI	4050 PSI	1/4" NPT-M	1/4" NPT-F	320° F	2.6 lbs.	10
YDL943	43"	10.5 GPM	3650 PSI	4050 PSI	1/4" NPT-M	1/4" NPT-F	320° F	2.4 lbs.	10

## Lance Accessories

*Product Group: I*

D20011	12" Gutter cleaner, 1/4" QC connectors, for use with #5.0 or larger nozzle
D22000	Adjustable lance handle for 1/4" lances

## Gun Lance Combination

*Product Group: I*

	GPM	RATED	MAX TEMP	INLET	OUTLET	SHW WT
DG320014	6.5 GPM	3200 PSI	195° F	1/4" NPT-F	M22-F	1.5 lbs.
DG320038	6.5 GPM	3200 PSI	195° F	3/8" NPT-F	M22-F	1.5 lbs.
DG3200M	6.5 GPM	3200 PSI	195° F	M22-M	M22-F	1.5 lbs.
DG400038	8.0 GPM	4000 PSI	195° F	3/8" NPT-F	M22-F	2.0 lbs.
DG4000M	8.0 GPM	4000 PSI	195° F	M22-M	M22-F	2.0 lbs.

DGLN3230M	Gun, lance, 1.3 mm nozzle, M22 inlet
DGLN3299M	Gun, lance, 0.99 mm nozzle, M22 inlet

## Lances

	LENGTH	RATED	MAX TEMP	INLET	OUTLET	SHW WT
DLE1618	16"	3200 PSI	195° F	M22-M	1/8" NPT-M	0.5 lbs.
DLE2218	22"	3200 PSI	195° F	M22-M	1/8" NPT-M	0.75 lbs.
DLE2818	28"	3200 PSI	195° F	M22-M	1/8" NPT-M	1.0 lbs.
DLE1614	16"	3200 PSI	195° F	M22-M	1/4" NPT-M	0.75 lbs.
DLE2214	22"	3200 PSI	195° F	M22-M	1/4" NPT-M	1.0 lbs.
DLE2814	28"	3200 PSI	195° F	M22-M	1/4" NPT-M	1.25 lbs.



**DLE1614**

## Flat Surface Cleaner

*Clean flat surfaces in a percentage of the time. The cleaner glides easily across the surface uniformly cleaning pool decks, sidewalks, garage floors and more. 20" cover made from heavy-duty ABS material. Metal surfaces made from heavy-duty anodized aluminum.*

	MAX GPM	RATED	MIN	DECK	MAX TEMP	INLET	NOZZLE	SHP WGHT
DFSCP18	8.0 GPM	4000 PSI	1000 PSI	18"	180° F	3/8" NPT-F	925020M	19 lbs.
DFSCP20	8.0 GPM	4000 PSI	1000 PSI	20"	180° F	3/8" NPT-F	925020M	24 lbs.

	PART NUMBER
CASTER KIT (4)	2100200
ROTARY HEAD	2103000
ROTARY HEAD KIT - MAJOR	2100202
ROTARY HEAD KIT - MINOR	2100203
ROTARY ARM	2530009
BRUSH SKIRT	2660044
NOZZLE - 2	925020M
GUN	DG4000FSC

**\*COMING SOON!** DFSCP Flat Surface Cleaner with Compensating Gun Feature!

## Hose Reels

Product Group: N

*Direct Hand Crank Rewind with locking mechanism, Solid Steel Construction with Durable Powdercoat Paint and Full Flow Swivel Brass Joint*

	DESCRIPTION	TEMP	MAX
D30001	50' x 3/8", complete with mounting base	225° F	3500 PSI
D30002	100' x 3/8", complete with mounting base	225° F	3500 PSI
D30004	150' x 3/8", complete with mounting base	225° F	3500 PSI
D30006	200' x 3/8", complete with mounting base	225° F	3500 PSI
DHR50100D	Industrial, 100' x 3/8", complete with mounting base and pigtail	225° F	5000 PSI
DHR50150D	Industrial, 150' x 3/8", complete with mounting base and pigtail	225° F	5000 PSI
SHR50150	High Temp, with Stainless Steel drum, 100' x 3/8", complete with mounting base	400° F	5000 PSI

Replacement Swivels

100887	Fits D30001, D30002
100056	Fits D30004, D30006
2103051	Fits DHR50100D, DHR50150D

## Water Brooms

Product Group: N

	DESCRIPTION	NOZZLE PORTS	PRESSURE
100869	12" Water Broom with 65 degree nozzles	3	3000 PSI
100870	16" Water Broom with 65 degree nozzles	4	3000 PSI
100869C	100869 with 36" Molded lance, 1/4" QC and High Pressure SS QC Filter	3	3000 PSI
100870C	100870 with 36" Molded lance, 1/4" QC and High Pressure SS QC Filter	4	3000 PSI



Flat Surface Cleaner



DHR50100D

**NEW!**



SHR50150



100870



100870C

# PRESSURE CLEANING ACCESSORIES

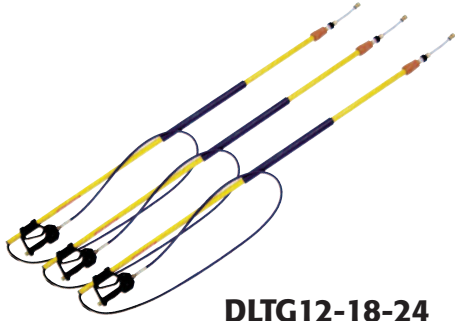

**DLTG12-18-24**

## The Giraffe – Telescoping Wands

*Product Group: I*

Cleaning Jobs up to 3 stories high, for use with hot or cold pressure washers. Nozzle holder accepts standard quick couple spray nozzles, gun included.

	LENGTH	GPM	MAX	OUTLET	MAX TEMP	RETRACTED DIMENSIONS	SHW WT
DLTG12	12 Feet	10.5 GPM	3500 PSI	1/4" QC	195° F	6.1" x 7' 5"	9.2 lbs.
DLTG18	18 Feet	10.5 GPM	3500 PSI	1/4" QC	195° F	6.1" x 7' 5"	11.6 lbs.
DLTG24	24 Feet	10.5 GPM	3500 PSI	1/4" QC	195° F	6.1" x 7' 8"	14.2 lbs.



**DLTG24A**

*Product Group: N*

D20015 Wand Belt - decreases strain on your back, shoulders and arms. Attaches to all General Pump Telescoping Wands.

All new aluminum pole, 3 sections, 5/16" double braid, 4,000 PSI hose. Lightweight aluminum pole.

	LENGTH	GPM	MAX	OUTLET	MAX TEMP	RETRACTED DIMENSIONS	SHW WT
DLTG18A	18 Feet	10.5 GPM	4000 PSI	1/4" QC	195° F	6.1" x 7' 5"	18.5 lbs.
DLTG24A	24 Feet	10.5 GPM	4000 PSI	1/4" QC	195° F	6.1" x 9' 5"	21.5 lbs.

**DLTG18A**

**COMING SOON!** Heavy duty all aluminum pole, 24 feet, 4 sections



**YLS12**

## Foamers

*Product Group: N*

	DESCRIPTION	GPM	RATED	MAX	SHW WT	BOX QTY
YLS12	Foamer Lance with 1.5 mm Injector	6.5 GPM	2900 PSI	3200 PSI	1.5 lbs.	45
YLS12T	Foamer Lance with 1.5 mm Injector (1 qt tank)	6.5 GPM	2900 PSI	3200 PSI	1.5 lbs.	5
YLS31T	Foamer Lance with 1.25 mm Injector	5.3 GPM	2300 PSI	2600 PSI	1.0 lbs.	5

**YLS12T**

ZOFOAM Foamer Nozzle Kit with Tank  
ZOSOAP 20 Soap Sticks for Brush Kit



**ZOFOAM**

## Brushes

*Product Group: N*

	DESCRIPTION	MAX TEMP	MAX	INLET	SHW WT	BOX QTY
YROTBRUSH 190092	Natural Bristle Rotating Brush YROTBRUSH with Lance	140° F	435 PSI	1/4" BSP-M	1.8 lbs.	21



**YROTBRUSH**



Black is a  
SOAP NOZZLE

# SPRAY TIPS & NOZZLES

## GENERAL PUMP

HIGH PRESSURE, SCREW-IN					HIGH PRESSURE, QUICK CONNECT				
NOZZLE SIZE	0°	15°	25°	40°	NOZZLE SIZE	0° (RED)	15° (YELLOW)	25° (GREEN)	40° (WHITE)
2.0	NOS-0002	NOS-1502	NOS-2502	NOS-4002	2.0	NOQS-0002	NOQS-1502	NOQS-2502	NOQS-4002
2.5	NOS-0002.5	NOS-1502.5	NOS-2502.5	NOS-4002.5	2.5	NOQS-0002.5	NOQS-1502.5	NOQS-2502.5	NOQS-4002.5
3.0	NOS-0003	NOS-1503	NOS-2503	NOS-4003	3.0	NOQS-0003	NOQS-1503	NOQS-2503	NOQS-4003
3.5	NOS-0003.5	NOS-1503.5	NOS-2503.5	NOS-4003.5	3.5	NOQS-0003.5	NOQS-1503.5	NOQS-2503.5	NOQS-4003.5
4.0	NOS-0004	NOS-1504	NOS-2504	NOS-4004	4.0	NOQS-0004	NOQS-1504	NOQS-2504	NOQS-4004
4.5	NOS-0004.5	NOS-1504.5	NOS-2504.5	NOS-4004.5	4.5	NOQS-0004.5	NOQS-1504.5	NOQS-2504.5	NOQS-4004.5
5.0	NOS-0005	NOS-1505	NOS-2505	NOS-4005	5.0	NOQS-0005	NOQS-1505	NOQS-2505	NOQS-4005
5.5	NOS-0005.5	NOS-1505.5	NOS-2505.5	NOS-4005.5	5.5	NOQS-0005.5	NOQS-1505.5	NOQS-2505.5	NOQS-4005.5
6.0	NOS-0006	NOS-1506	NOS-2506	NOS-4006	6.0	NOQS-0006	NOQS-1506	NOQS-2506	NOQS-4006
6.5	NOS-0006.5	NOS-1506.5	NOS-2506.5	NOS-4006.5	6.5	NOQS-0006.5	NOQS-1506.5	NOQS-2506.5	NOQS-4006.5
7.0	NOS-0007	NOS-1507	NOS-2507	NOS-4007	7.0	NOQS-0007	NOQS-1507	NOQS-2507	NOQS-4007
7.5	NOS-0007.5	NOS-1507.5	NOS-2507.5	NOS-4007.5	7.5	NOQS-0007.5	NOQS-1507.5	NOQS-2507.5	NOQS-4007.5
8.0	NOS-0008	NOS-1508	NOS-2508	NOS-4008	8.0	NOQS-0008	NOQS-1508	NOQS-2508	NOQS-4008
8.5	NOS-0008.5	NOS-1508.5	NOS-2508.5	NOS-4008.5	8.5	NOQS-0008.5	NOQS-1508.5	NOQS-2508.5	NOQS-4008.5
9.0	NOS-0009	NOS-1509	NOS-2509	NOS-4009	9.0	NOQS-0009	NOQS-1509	NOQS-2509	NOQS-4009
10	NOS-0010	NOS-1510	NOS-2510	NOS-4010	10	NOQS-0010	NOQS-1510	NOQS-2510	NOQS-4010

'QC' Nozzle Color Codes - 0° (Red) 15° (Yellow) 25° (Green) 40° (White)

# SPRAY TIPS & NOZZLES



**ASSORTED NOZZLES**



**Nozzle 5-Pack**



**Nozzle 4-Pack**

## Chemical Nozzles

*Product Group: O*

	DESCRIPTION	SHP WGHT	BOX QTY
915500MSS	#50 Orifice, 15° Spray Angle, Stainless Steel, 1/4" NPT-M	0.1 lbs.	250
915500QB	#50 Orifice, 15° Spray Angle, Brass, Q-Style	0.1 lbs.	250
965400M	#40 Orifice, 65° Spray Angle, 1/4" NPT-M	0.1 lbs.	250
965400Q	#40 Orifice, 65° Spray Angle, Q-Style, 100% Brass	0.1 lbs.	250
965400S	#40 Orifice, 65° Spray Angle, 1/8" NPT-M, 100% Brass	0.1 lbs.	250
925400M	#40 Orifice, 25° Spray Angle, 1/4" NPT-M	0.1 lbs.	250
925400Q	#40 Orifice, 25° Spray Angle, Q-Style, 100% Brass	0.1 lbs.	250
925400S	#40 Orifice, 25° Spray Angle, 1/8" NPT-M, 100% Brass	0.1 lbs.	250

## Nozzle 5-Pack, 1/4" Quick Disconnect

*Product Group: P*

*(one each: 0°, 15°, 25°, 40°; plus one 65° #40 chemical)*

	DESCRIPTION	SHP WGHT
105082	#3.0	0.5 lbs.
105083	#3.5	0.5 lbs.
105084	#4.0	0.5 lbs.
105085	#4.5	0.5 lbs.
105086	#5.0	0.5 lbs.
105087	#5.5	0.5 lbs.
105088	#6.0	0.5 lbs.
105089	#6.5	0.5 lbs.
105090	#7.0	0.5 lbs.

## Nozzle 4-Pack, 1/4" Quick Disconnect

*Product Group: P*

*(one each: 0°, 15°, 25°, and 40°)*

	DESCRIPTION	SHP WGHT
105120	#3.5	0.5 lbs.
105121	#4.0	0.5 lbs.
105122	#4.5	0.5 lbs.
105123	#5.0	0.5 lbs.
105124	#5.5	0.5 lbs.
105125	#6.0	0.5 lbs.
105126	#6.5	0.5 lbs.

## Adjustable Nozzle, Variable Spray Angle and High/Low Pressure Setting

Product Group: A

	SIZE/COLOR	RATED	MAX	MAX TEMP	INLET	SHP WGHT	BOX QTY
YHL20	#2.0 Light Green	3650 PSI	4050 PSI	195° F	1/4" BSP-F	0.4 lbs.	10
YHL25	#2.5 Pink	3650 PSI	4050 PSI	195° F	1/4" BSP-F	0.4 lbs.	10
YHL30	#3.0 White	3650 PSI	4050 PSI	195° F	1/4" BSP-F	0.4 lbs.	10
YHL35	#3.5 Brown	3650 PSI	4050 PSI	195° F	1/4" BSP-F	0.4 lbs.	10
YHL40	#4.0 Dark Yellow	3650 PSI	4050 PSI	195° F	1/4" BSP-F	0.4 lbs.	10
YHL45	#4.5 Blue	3650 PSI	4050 PSI	195° F	1/4" BSP-F	0.4 lbs.	10
YHL50	#5.0 Light Purple	3650 PSI	4050 PSI	195° F	1/4" BSP-F	0.4 lbs.	10
YHL55	#5.5 Dark Red	3650 PSI	4050 PSI	195° F	1/4" BSP-F	0.4 lbs.	10
YHL60	#6.0 Dark Green	3650 PSI	4050 PSI	195° F	1/4" BSP-F	0.4 lbs.	10
YHL70	#7.0 Orange	3650 PSI	4050 PSI	195° F	1/4" BSP-F	0.4 lbs.	10
YHL80	#8.0 Silver	3650 PSI	4050 PSI	195° F	1/4" BSP-F	0.4 lbs.	10



YHL20

## Adjustable Spray High/Low Pressure Nozzle

	SIZE/COLOR	RATED	TEMP	MAX INLET	SHP WGHT
DHL4086	0.86 mm/Green	3200 PSI	195° F	1/4" NPT-F	0.5 lbs.
DHL4099	0.99 mm/Pink	3200 PSI	195° F	1/4" NPT-F	0.5 lbs.
DHL4120	1.2 mm/Brown	3200 PSI	195° F	1/4" NPT-F	0.5 lbs.
DHL4130	1.3 mm/Yellow	3200 PSI	195° F	1/4" NPT-F	0.5 lbs.
DHL4140	1.4 mm/Blue	3200 PSI	195° F	1/4" NPT-F	0.5 lbs.
DHL4150	1.5 mm/Red	3200 PSI	195° F	1/4" NPT-F	0.5 lbs.
DHL4160	1.6 mm/Green	3200 PSI	195° F	1/4" NPT-F	0.5 lbs.
DHL4170	1.7 mm/Orange	3200 PSI	195° F	1/4" NPT-F	0.5 lbs.
DHL4180	1.8 mm/Silver	3200 PSI	195° F	1/4" NPT-F	0.5 lbs.



DHL4120

## Adjustable Nozzle, Premium High/Low Pressure Setting and Variable Spray Angle

Product Group: A

	SIZE/COLOR	RATED	MAX	MAX TEMP	INLET	SHP WGHT	BOX QTY
YHILO110	#3.0 White	4050 PSI	4500 PSI	195° F	1/4" BSP-F	0.5 lbs.	10
YHILO120	#3.5 Brown	4050 PSI	4500 PSI	195° F	1/4" BSP-F	0.5 lbs.	10
YHILO130	#4.0 Yellow	4050 PSI	4500 PSI	195° F	1/4" BSP-F	0.5 lbs.	10
YHILO140	#4.5 Blue	4050 PSI	4500 PSI	195° F	1/4" BSP-F	0.5 lbs.	10
YHILO150	#5.5 Red	4050 PSI	4500 PSI	195° F	1/4" BSP-F	0.5 lbs.	10
YHILO160	#6.0 Dark Green	4050 PSI	4500 PSI	195° F	1/4" BSP-F	0.5 lbs.	10
YHILO170	#7.0 Orange	4050 PSI	4500 PSI	195° F	1/4" BSP-F	0.5 lbs.	10



YHILO

	GPM	MAXIMUM	MAX TEMP	INLET	SHP WGHT
ZOMULTIREG99	5.5 GPM	3000 PSI	140° F	1/4" BSP-F	1.1 lbs.



ZOMULTIREG99



# SPRAY TIPS & NOZZLES

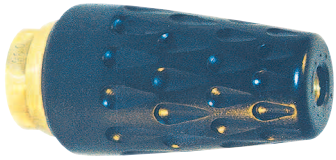

**Y3K**



**Y5K**

## Rotating Nozzle

Product Group: A

	SIZE	MAX	MAX TEMP	INLET	SHP WGHT
Y3K020	2.0	3000 PSI	194° F	1/4" BSP-F	.75 lbs.
Y3K030	3.0	3000 PSI	194° F	1/4" BSP-F	.75 lbs.
Y3K035	3.5	3000 PSI	194° F	1/4" BSP-F	.75 lbs.
Y3K040	4.0	3000 PSI	194° F	1/4" BSP-F	.75 lbs.
Y3K045	4.5	3000 PSI	194° F	1/4" BSP-F	.75 lbs.
Y3K050	5.0	3000 PSI	194° F	1/4" BSP-F	.75 lbs.
Y3K055	5.5	3000 PSI	194° F	1/4" BSP-F	.75 lbs.
Y3K065	6.5	3000 PSI	194° F	1/4" BSP-F	.75 lbs.
Y5K020	2.0	5000 PSI	194° F	1/4" BSP-F	1.75 lbs.
Y5K030	3.0	5000 PSI	194° F	1/4" BSP-F	1.75 lbs.
Y5K035	3.5	5000 PSI	194° F	1/4" BSP-F	1.75 lbs.
Y5K040	4.0	5000 PSI	194° F	1/4" BSP-F	1.75 lbs.
Y5K045	4.5	5000 PSI	194° F	1/4" BSP-F	1.75 lbs.
Y5K050	5.0	5000 PSI	194° F	1/4" BSP-F	1.75 lbs.
Y5K055	5.5	5000 PSI	194° F	1/4" BSP-F	1.75 lbs.
Y5K060	6.0	5000 PSI	194° F	1/4" BSP-F	1.75 lbs.
Y5K065	6.5	5000 PSI	194° F	1/4" BSP-F	1.75 lbs.
Y5K090	9.0	5000 PSI	194° F	1/4" BSP-F	1.75 lbs.
Y5K100	10.0	5000 PSI	194° F	1/4" BSP-F	1.75 lbs.

## Rotating Nozzle

Product Group: A

Shock resistant ceramic, internal stabilization spring, can be operated in any direction. YR23 is designed for lower pressures, YR36 is designed to operate at pressures most common in the market and YR51 is for higher pressures for more demanding applications.



**YR23K40**



**YR36K30**



**YR51K30**

	SIZE	MIN PRESSURE	MAX PRESSURE	MAX TEMP	INLET	SHP WGHT	SHP QTY
YR23K40	4.0	435 PSI	2300 PSI	212° F	1/4" BSP-F	0.9 lbs.	5
YR23K45	4.5	435 PSI	2300 PSI	212° F	1/4" BSP-F	0.9 lbs.	5
YR23K50	5.0	435 PSI	2300 PSI	212° F	1/4" BSP-F	0.9 lbs.	5
YR23K55	5.5	435 PSI	2300 PSI	212° F	1/4" BSP-F	0.9 lbs.	5
YR23K60	6.0	435 PSI	2300 PSI	212° F	1/4" BSP-F	0.9 lbs.	5
YR23K65	6.5	435 PSI	2300 PSI	212° F	1/4" BSP-F	0.9 lbs.	5
YR23K70	7.0	435 PSI	2300 PSI	212° F	1/4" BSP-F	0.9 lbs.	5
YR36K30	3.0	1150 PSI	3650 PSI	212° F	1/4" BSP-F	0.9 lbs.	5
YR36K35	3.5	1150 PSI	3650 PSI	212° F	1/4" BSP-F	0.9 lbs.	5
YR36K40	4.0	1150 PSI	3650 PSI	212° F	1/4" BSP-F	0.9 lbs.	5
YR36K45	4.5	1150 PSI	3650 PSI	212° F	1/4" BSP-F	0.9 lbs.	5
YR36K50	5.0	1150 PSI	3650 PSI	212° F	1/4" BSP-F	0.9 lbs.	5
YR36K55	5.5	1150 PSI	3650 PSI	212° F	1/4" BSP-F	0.9 lbs.	5
YR36K60	6.0	1150 PSI	3650 PSI	212° F	1/4" BSP-F	0.9 lbs.	5
YR36K65	6.5	1150 PSI	3650 PSI	212° F	1/4" BSP-F	0.9 lbs.	5
YR36K70	7.0	1150 PSI	3650 PSI	212° F	1/4" BSP-F	0.9 lbs.	5
YR36K80	8.0	1150 PSI	3650 PSI	212° F	1/4" BSP-F	0.9 lbs.	5
YR51K30	3.0	2600 PSI	5100 PSI	212° F	1/4" BSP-F	0.9 lbs.	5
YR51K35	3.5	2600 PSI	5100 PSI	212° F	1/4" BSP-F	0.9 lbs.	5
YR51K40	4.0	2600 PSI	5100 PSI	212° F	1/4" BSP-F	0.9 lbs.	5
YR51K45	4.5	2600 PSI	5100 PSI	212° F	1/4" BSP-F	0.9 lbs.	5
YR51K50	5.0	2600 PSI	5100 PSI	212° F	1/4" BSP-F	0.9 lbs.	5
YR51K55	5.5	2600 PSI	5100 PSI	212° F	1/4" BSP-F	0.9 lbs.	5
YR51K60	6.0	2600 PSI	5100 PSI	212° F	1/4" BSP-F	0.9 lbs.	5
YR51K65	6.5	2600 PSI	5100 PSI	212° F	1/4" BSP-F	0.9 lbs.	5
YR51K70	7.0	2600 PSI	5100 PSI	212° F	1/4" BSP-F	0.9 lbs.	5
YR51K80	8.0	2600 PSI	5100 PSI	212° F	1/4" BSP-F	0.9 lbs.	5



**ZROTOMAX**



**ZRMAX581**

## Adjustable Rotating Nozzle

Product Group: A

	COLOR	GPM	RATED	MAX	MAX TEMP	INLET	BEAR WGHT	QTY
ZROTOMAX1	Red	2.1 to 2.6 GPM	1450 PSI	3500 PSI	176° F	1/4" BSP-F	1.1 lbs.	15
ZROTOMAX2	Light Blue	2.9 to 4.0 GPM	1450 PSI	3500 PSI	176° F	1/4" BSP-F	1.1 lbs.	15
ZROTOMAX3	Black	4.2 to 5.5 GPM	1450 PSI	3500 PSI	176° F	1/4" BSP-F	1.1 lbs.	15
	ORIFICE	GPM	MAX	INLET	MAX TEMP	SHP WGHT	QTY	
ZRMAX581	140	2.3 to 4.7 GPM	5800 PSI	1/4" BSP-F	176° F	0.7 lbs.	0.7 lbs.	
ZRMAX583	160	3.3 to 6.6 GPM	5800 PSI	1/4" BSP-F	176° F	0.7 lbs.	0.7 lbs.	

\* 1/2" BSP- F Inlet Optional

## GP Viper Rotating Nozzle

Product Group: A

	SIZE	MAX	MAX TEMP	SHP WGHT
100467	#5.5	5000 PSI	190° F	1.1 lbs.
100487	#4.5	5000 PSI	190° F	1.1 lbs.



100467

## Stainless Steel Rotating Nozzle

Product Group: K

	SIZE	MAX	MAX TEMP	INLET	SHP WGHT
Y7K040	4.0	7000 PSI	194° F	1/4" BSP-F	1.5 lbs.
Y7K045	4.5	7000 PSI	194° F	1/4" BSP-F	1.5 lbs.
Y7K050	5.0	7000 PSI	194° F	1/4" BSP-F	1.5 lbs.
Y7K055	5.5	7000 PSI	194° F	1/4" BSP-F	1.5 lbs.
Y7K060	6.0	7000 PSI	194° F	1/4" BSP-F	1.5 lbs.
Y7K065	6.5	7000 PSI	194° F	1/4" BSP-F	1.5 lbs.
Y7K070	7.0	7000 PSI	194° F	1/4" BSP-F	1.5 lbs.



Y7K

## Drain Cleaning Nozzles

Product Group: A

	DESCRIPTION	GPM	MAX	INLET	SHP WGHT
YDRNT1	Microdrain, Brass, #3.5	2.3 GPM	1750 PSI	1/4" BSP-M	0.2 lbs.
YDRNT2	Microdrain, Stainless Steel, #4.0	3.8 GPM	3650 PSI	1/4" BSP-M	0.2 lbs.
YDRNT3	Microdrain, Stainless Steel, #6.0	5.7 GPM	3650 PSI	3/8" BSP-M	0.2 lbs.
ZUDRNT	Drainet, Adjustable Equivalent Orifice Diameter	16.0 GPM	3000 PSI	3/8" BSP-M	0.3 lbs.
ZUMDRNT1	Microdrain, #5.5 Equivalent Orifice Diameter	5.1 GPM	3500 PSI	1/8" BSP-F	0.2 lbs.
ZUMDRNT2	Microdrain, #8.5 Equivalent Orifice Diameter	7.4 GPM	3000 PSI	1/8" BSP-F	0.2 lbs.



YDRNT

## Adjustable Nozzle Holder

Product Group: H

	GPM	MAX	INLET	OUTLET	SHP WGHT
YADJNOZ	8 GPM	3650 PSI	1/4" BSP-F	1/4" BSP-F	0.5 lbs.



YADJNOZ

## Double Nozzle Holders

Product Group: H

	GPM	MAX	INLET	OUTLET	SHP WGHT
YDBL14	10.5 GPM	2900 PSI	1/4" BSP-F	(2) 1/4" NPT-F	0.5 lbs.
YDBL18	10.5 GPM	2900 PSI	1/4" BSP-F	(2) 1/8" NPT-F	0.5 lbs.
ZUDBL	5.5 GPM	3000 PSI	1/4" BSP-F	(2) 1/4" BSP-F	0.5 lbs.

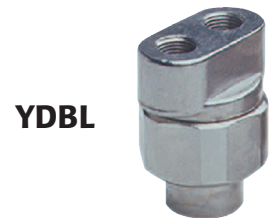

YDBL

## Steam Nozzle

Product Group: A

	DESCRIPTION	MAX	INLET	SHP WGHT
YSTN14F	1.5 mm, .06 Nozzle	1450 PSI	1/4" BSP-F	0.3 lbs.



YSTN14F

# SPRAY TIPS & NOZZLES

## Tank Cleaning Nozzles

Product Group: K



**Y25450000**

	DESCRIPTION	GPM	MAX	SHW WGHT
Y25450000	M63 Electric for small openings, 24v	4.0 to 10.5 GPM	2000 PSI	14.0 lbs.
Y25477000	M85 Electric for large openings, 24v	21.0 GPM	2000 PSI	14.0 lbs.



**Y25460000**

Y25460000	M63 Self Propelled for small openings	4.0 to 10.5 GPM	2000 PSI	14.0 lbs.
Y25475000	M85 Self Propelled for large openings	21.0 GPM	2000 PSI	14.0 lbs.



**Y25459000**

Y25459000	M63 Pneumatic for small openings	4.0 to 10.5 GPM	2000 PSI	10.0 lbs.
Y25479500	M85 Pneumatic for large openings	21.0 GPM	2000 PSI	11.5 lbs.



**Y25482000**

Y25482000	A-80R Self Propelled Request modified version when using non-rigid drop	6.0 to 32.0 GPM	2000 PSI	11.0 lbs.
Y25485000	A-80R2 Self Propelled (High RPM Version) Request modified version when using non-rigid drop	6.0 to 21.0 GPM	2000 PSI	11.0 lbs.



**Y25430060**

Y25430060	M21 Electric for barrel cleaning - Wine, chemical, etc. - For use with pressure washer - 110v	5.5 GPM	3200 PSI	7.0 lbs.
-----------	--	---------	----------	----------

Y25435060	M25E Electric for barrel cleaning - With suction capability - 110v	6.5 GPM	2300 PSI	9.0 lbs.
-----------	--	---------	----------	----------



**Y25438060**

Y25438060	M28E Electric for barrel cleaning - With 90° motor for small area - With suction capability	6.5 GPM	2300 PSI	9.0 lbs.
-----------	---	---------	----------	----------

## Quick Disconnect Couplers – EPDM O-Ring

Product Group: H

	DESCRIPTION	MAX
D10001	1/4" with 1/4" NPT-F	5000 PSI
D10003	3/8" with 3/8" NPT-F	4000 PSI
D10002	1/4" with 1/4" NPT-M	5000 PSI
D10004	3/8" with 3/8" NPT-M	4000 PSI
D10005	3/8" with 1/2" NPT-M	4000 PSI
D10035	3/8" with M22	4000 PSI
D10088	3/8" with M22-F	4000 PSI
D10097	1/4" with 1/4" NPT-F (one touch)	5000 PSI
D10098	3/8" with 3/8" NPT-F (one touch)	4000 PSI

## Easy-Grip Quick Connect Couplers

	DESCRIPTION	MAX
D10061	1/4" with 1/4" NPT-F, with Easy-Grip Feature	5000 PSI
D10062	1/4" with 1/4" NPT-M, with Easy-Grip Feature	5000 PSI
D10063	3/8" with 3/8" NPT-F, with Easy-Grip Feature	4000 PSI
D10064	3/8" with 3/8" NPT-M, with Easy-Grip Feature	4000 PSI

## Quick Disconnect Plugs

Product Group: H

	DESCRIPTION	MAX TEMP	MAX
D10006	1/4" Plug with 1/4" NPT-F, Hardened Steel, Brass Plated	175° F	5000 PSI
D10007	1/4" Plug with 1/4" NPT-M, Hardened Steel, Brass Plated	175° F	5000 PSI
D10008	3/8" Plug with 3/8" NPT-F, Hardened Steel, Brass Plated	175° F	4000 PSI
D10009	3/8" Plug with 3/8" NPT-M, Hardened Steel, Brass Plated	175° F	4000 PSI
100746	3/8" Plug with M22 Coupler	175° F	4000 PSI
D10089	3/8" Plug with M22-M	175° F	4000 PSI
520133	1/4" Plug with 1/4" NPT-F, Hardened Stainless Steel		5500 PSI
520134	1/4" Plug with 1/4" NPT-M, Hardened Stainless Steel		5500 PSI
520135	3/8" Plug with 3/8" NPT-F, Hardened Stainless Steel		5000 PSI
520136	3/8" Plug with 3/8" NPT-M, Hardened Stainless Steel		5000 PSI

## Stainless Steel Quick Disconnect Couplers

Product Group: H

	DESCRIPTION	MAX
D10072	1/4" with 1/4" NPT-F, Stainless Steel	6000 PSI
D10073	1/4" with 1/4" NPT-M, Stainless Steel	6000 PSI
D10074	3/8" with 3/8" NPT-F, Stainless Steel	5000 PSI
D10075	3/8" with 3/8" NPT-M, Stainless Steel	5000 PSI
D10090	1/2" with 1/2" NPT-F, Stainless Steel	5000 PSI
D10091	1/2" with 1/2" NPT-M, Stainless Steel	5000 PSI

## Stainless Steel Disconnect Plugs

Product Group: H

	DESCRIPTION	MAX
D10076	1/4" Plug with 1/4" NPT-F, Stainless Steel	6000 PSI
D10077	1/4" Plug with 1/4" NPT-M, Stainless Steel	6000 PSI
D10078	3/8" Plug with 3/8" NPT-F, Stainless Steel	5000 PSI
D10079	3/8" Plug with 3/8" NPT-M, Stainless Steel	5000 PSI
D10092	1/2" Plug with 1/2" NPT-F, Stainless Steel	5000 PSI
D10093	1/2" Plug with 1/2" NPT-M, Stainless Steel	5000 PSI

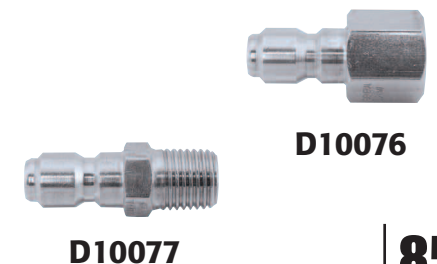
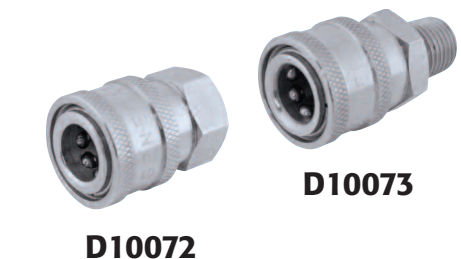
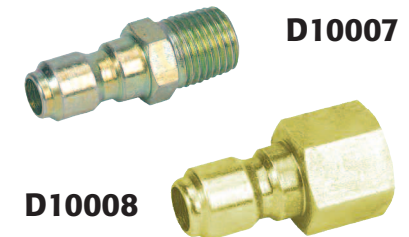
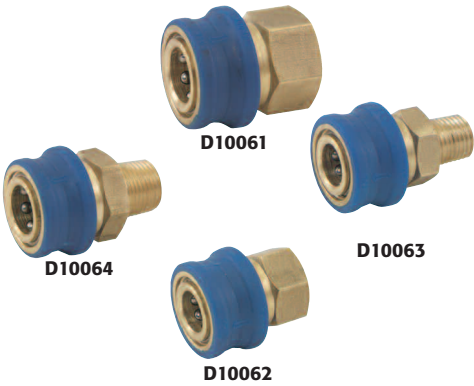

# COUPLERS & FITTINGS



**D10010**



**100275**



**D10084**



**D10017**



**D10032**



**700004**

## Garden Hose Fittings

*Product Group: H*

	DESCRIPTION	INLET	OUTLET
D10010	Garden Hose Assembly	3/4" M Garden Hose	1/2" QD-M
D10011	Plug	3/4" M Garden Hose	1/2" QD-M
D10012	Coupler	3/4" F Garden Hose	1/2" QD

100275	Garden Hose Adapter Kit	3/4" Garden Hose	1/2" NPT-M
100276	Garden Hose Adapter Kit	3/4" Garden Hose	1/2" NPT-F
100277	Garden Hose Adapter Kit	3/4" Garden Hose	3/8" NPT-M

	DESCRIPTION	PORT	INLET	OUTLET
D10084	Garden Hose Inlet, Long	1/4" NPT-F	3/4" Garden Hose	3/8" BSP-M
D10085	Garden Hose Inlet, Long	1/4" NPT-F	3/4" Garden Hose	1/2" NPT-M

## Garden Hose Fittings with Screens

	DESCRIPTION	INLET	OUTLET
D10016	Garden Hose Fitting, with screen	3/4" Garden Hose	1/2" NPT-F
D10017	Garden Hose Fitting, with screen	3/4" Garden Hose	3/8" NPT-F
D10032	Garden Hose Fitting, with screen	3/4" Garden Hose	1/2" NPT-M
D10033	Garden Hose Fitting, with screen	3/4" Garden Hose	3/8" NPT-M

	DESCRIPTION	PORT	INLET	OUTLET
680006	Garden Hose Inlet for TP Series 51 Pumps, with O-Ring (long)		3/4" Garden Hose	1/2" BSP-M
680007	Garden Hose Assembly	1/4" NPT-F	3/4" Garden Hose	3/8" BSP-M
680073	Garden Hose Inlet for TP/TT Series (Short)		3/4" Garden Hose	1/2" BSP-M

700034	Garden Hose Filter Washer, Stainless Steel, 30 mesh
700004	Garden Hose Filter Washer, Stainless Steel, 50 mesh
720039	Garden Hose Retention Spring, Stainless Steel

## Quick Disconnect Fittings – Twist Connect

Product Group: H

	DESCRIPTION	RATED	MAX	SHP WGHT
ZMINA14F	1/4" F Plug	3000 PSI	3000 PSI	0.2 lbs.
ZMINA14M	1/4" M Plug	3000 PSI	3000 PSI	0.2 lbs.
ZMINA38F	3/8" F Plug	3000 PSI	3000 PSI	0.2 lbs.
ZMINB12M	1/2" M Coupler	3000 PSI	3000 PSI	0.2 lbs.
ZMINB14F	1/4" F Coupler	3000 PSI	3000 PSI	0.2 lbs.
ZMINB14M	1/4" M Coupler	3000 PSI	3000 PSI	0.2 lbs.
ZMINB38F	3/8" F Coupler	3000 PSI	3000 PSI	0.2 lbs.
ZMINB38M	3/8" M Coupler	3000 PSI	3000 PSI	0.2 lbs.

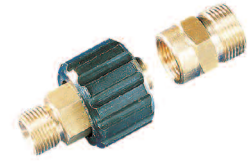

**ZMINA-ZMINB**

	DESCRIPTION	RATED	SHP WGHT
D10022	1/4" F Plug x M22	4000 PSI	0.2 lbs.
D10021	1/4" M Plug x M22	4000 PSI	0.2 lbs.
D10023	3/8" M Plug x M22	4000 PSI	0.2 lbs.
D10024	3/8" F Plug x M22	4000 PSI	0.2 lbs.

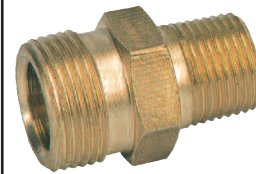

**D10023**

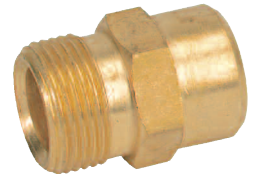

**D10024**

EPDM O-Ring

	DESCRIPTION	RATED	SHP WGHT
D10027	1/4" F Coupler, 1 O-Ring, M22	4000 PSI	0.2 lbs.
D10028	1/4" M Coupler, 1 O-Ring, M22	4000 PSI	0.2 lbs.
D10029	3/8" F Coupler, 1 O-Ring, M22	4000 PSI	0.2 lbs.
D10030	3/8" M Coupler, 1 O-Ring, M22	4000 PSI	0.2 lbs.



**D10030**



**D10028**

	DESCRIPTION	RATED	SHP WGHT
D10040	M22 QD Plug x M22 QD Plug	4000 PSI	0.1 lbs.
D10041	M22 Coupler x M22 Coupler	4000 PSI	0.3 lbs.
D10043	Brass Pipe Thread Reducer, 3/8" NPT-M x 1/4" NPT-F	4500 PSI	0.2 lbs.
D10044	Brass Pipe Coupling, 1/4" NPT-F	4000 PSI	0.1 lbs.
D10037	M22 Coupler x 3/8" QD Plug	4000 PSI	0.2 lbs.
D10052	Union, 3/8" NPT-M x 3/8" NPT-M, Steel	5000 PSI	0.2 lbs.



**D10037**



**D10044**



**D10041**



**D10040**

# FILTERS & STRAINERS



**100560**

## Inline High-Pressure Filters

*Product Group: G*

	DESCRIPTION	GPM	MAX	MAX TEMP	INLET	OUTLET	SHP WGHT
100560	100 Mesh Screen, 416 Stainless Steel	8.0 GPM	5500 PSI	200° F	1/4" QD	1/4" NPT	0.5 lbs.
100622	100 Mesh Screen, Brass	8.0 GPM	5000 PSI	200° F	1/4" NPT-M	1/4" NPT-M	0.5 lbs.
100647	100 Mesh Screen, Brass	8.0 GPM	5000 PSI	200° F	1/4" NPT-F	1/4" NPT-M	0.5 lbs.



**100622**



**YF00**

## Chemical Filters

*Product Group: G*

	DESCRIPTION	SHP WGHT
ZOFILKIT	Chemical Hose & Filter	0.5 lbs.
YF00	Plastic Chemical Filter, 1/4" Hose Barb	0.3 lbs.
YF00C	Plastic Chemical Filter with Check, 1/4" Hose Barb	0.3 lbs.
YF30	Plastic Chemical Filter with Stainless Steel Plug, 1/4" Hose Barb	0.3 lbs.
YF30C	Plastic Chemical Filter with Stainless Steel Plug with Check, 1/4" Hose Barb	0.3 lbs.
D40001	Plastic Chemical Filter with Check Valve, 1/4" Hose Barb and 4 Foot Hose	0.5 lbs.



**YF00C**



**D40003**



**D40013**

	DESCRIPTION	SHP WGHT
D40003	Plastic chemical filter with check valve, gray	0.3 lbs.
D40006	Plastic two-step chemical filter with no check valve, black	0.3 lbs.
D40013	Chemical filter Brass/SS	0.5 lbs.



**ZF1**



**ZF2**

	DESCRIPTION	SHP WGHT	BOX QTY
ZF1	Plastic filter with Brass Hose Barb, 1/4" Hose Barb	0.2 lbs.	30
ZF2	Plastic filter with Brass Hose Barb with Check, 1/4" Hose Barb	0.3 lbs.	30

## Inlet Filter

Product Group: G

Integrated Garden Hose Nut

	DESCRIPTION	GPM	MIN	MAX	INLET	OUTLET	BYPASS	SHP WGHT
100649	Integrated Garden Hose Nut	8.0 GPM	15 PSI	150 PSI	3/4" GH	1/2" NPT-M	-	0.5 lbs.
100650	Integrated Garden Hose Nut	8.0 GPM	15 PSI	150 PSI	3/4" GH	3/8" NPT-M	-	0.5 lbs.



**100649**

100651	Integrated Garden Hose Nut	8.0 GPM	15 PSI	150 PSI	3/4" GH	1/2" NPT-M	1/4"	0.5 lbs.
100652	Integrated Garden Hose Nut	8.0 GPM	15 PSI	150 PSI	3/4" GH	3/8" NPT-M	1/4"	0.5 lbs.



**100652**

	DESCRIPTION	GPM	MAX	INLET	OUTLET	SHP WGHT
ZMFIL	Aluminum Body, 50 Mesh	5.8 GPM	145 PSI	1/2" BSP-F	1/2" BSP-M	0.5 lbs.



**ZMFIL**

## Inlet Strainers

Product Group: G

	DESCRIPTION	GPM	MAX	INLET	OUTLET	BYPASS	SHP WGHT
YF5BMF	Plastic Body, 50 Mesh	8 GPM	145 PSI	1/2" BSP-M	1/2" BSP-F	1/4"	0.5 lbs.
YF5MF	Plastic Body, 50 Mesh	8 GPM	145 PSI	1/2" BSP-M	1/2" BSP-F	-	0.5 lbs.
YFY1	Plastic Body, 50 Mesh	21 GPM	145 PSI	1" BSP-F	1" BSP-F	-	0.5 lbs.
YFY34	Plastic Body, 50 Mesh	21 GPM	145 PSI	3/4" BSP-F	3/4" BSP-F	-	0.5 lbs.



**YFY1**

YYSTR12	Brass Body, 45 Mesh	15 GPM	175 PSI	1/2" NPT-F	1/2" NPT	-	0.3 lbs.
---------	---------------------	--------	---------	------------	----------	---	----------

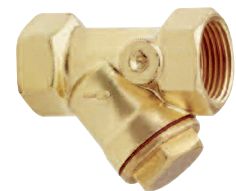

**YYSTR12**



# GAUGES & SWITCHES



**100272**

## Thermostats

*Product Group: R*

	DESCRIPTION	GPM	MAX	INLET	OUTLET	SHP WGHT
100272	Flow Through Style	1 to 35 GPM	5000 PSI	1/2" NPT	1/2" NPT	1.0 lbs.

Probe Style Thermostats Insulated SS Capillary Copper Immersion Bulb (UL/CSA approved).



**100438**

	RATING	PRESSURE	MAX TEMP	SHP WGHT
100438	16(4)A-380V Electric Rating	4000 PSI	86-194°	0.5 lbs.
100439	16(4)A-380V Electric Rating	4000 PSI	86-320°	0.5 lbs.
100538	16(4)A-380V Electric Rating	4000 PSI	86-250°	0.5 lbs.

*Thermostats Bulk Packaged (25 per box) Product Group: B*

100438B	16(4)A-380V Electric Rating	4000 PSI	86-194°	12.5 lbs.
100439B	16(4)A-380V Electric Rating	4000 PSI	86-320°	12.5 lbs.
100538B	16(4)A-380V Electric Rating	4000 PSI	86-250°	12.5 lbs.



**Y29026035**

Y29026035	Probe Pocket	4500 PSI	N/A	0.4 lbs.
-----------	--------------	----------	-----	----------

## Pressure Switches

*Product Group: D*



**YPRESSWITCH**

	ACTIVATED PRESSURE	RATED PRESSURE	MAX TEMP	INLET	SHP WGHT
<i>15 amps, 250 Volts, 580 Switching Pressure, Brass Stem, Stainless Steel Nipple</i>					
YPRESSWITCH	580 PSI	3600 PSI	195° F	1/4" NPT-M	0.5 lbs.
YPRSWITCHXL (67" lead)	580 PSI	3600 PSI	195° F	1/4" NPT-M	0.5 lbs.

<i>15 amps, 250 Volts, 360 Switching Pressure, Brass Stem, Stainless Steel Nipple</i>					
YPRESSWITCH1535	360 PSI	3600 PSI	195° F	3/8" BSP-M	0.5 lbs.

<i>15 amps, 250 Volts, 580 Switching Pressure, Brass Stem, Stainless Steel Nipple</i>					
YPRESSWITCH1564	580 PSI	3600 PSI	195° F	3/8" BSP-M	0.5 lbs.

<i>5 amps, 250 Volts, 360 Switching Pressure, Brass Stem and Nipple</i>					
YPRESSWITCH535	360 PSI	3600 PSI	195° F	1/4" BSP-M	0.5 lbs.

<i>5 amps, 250 Volts, 580 Switching Pressure, Brass Stem and Nipple</i>					
YPRESSWITCH564	580 PSI	3600 PSI	195° F	1/4" BSP-M	0.5 lbs.

<i>15 amps, 250 Volts, 650 Switching Pressure, Stainless Steel Stem and Nipple</i>					
YPRESSWITCHHP	650 PSI	5800 PSI	195° F	3/8" BSP-M	0.5 lbs.

<i>15 amps, 250 Volts, 215 Switching Pressure, Stainless Steel Stem and Nipple</i>					
YPRESSWITCH1521	215 PSI	3600 PSI	195° F	1/4" NPT-M	0.5 lbs.

<i>5 amps, 250 Volts, 215 Switching Pressure, Stainless Steel Stem and Nipple</i>					
YPRESSWITCH521	215 PSI	3600 PSI	195° F	1/4" NPT-M	0.5 lbs.

<i>5 amps, 250 Volts, 435 Switching Pressure, Brass Stem and Nipple</i>					
ZMSIMPLEX3	725 PSI	3000 PSI		1/4" BSP-M	0.5 lbs.

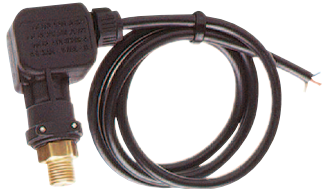

**YPRESSWITCH535**



**ZMSIMPLEX3**

## Reedless Flow Switch

*Product Group: D*

*TMT Inline Flowswitch, 5 amp micro switch, minimum flow 0.5 GPM activation, 48" 18 awg lead, no spring, uses magnets for all movements*

	GPM	MAX	MAX TEMP	INLET	OUTLET	VOLTAGE	MATERIAL	SHP WGHT
100934	12.0 GPM	5000 PSI	180° F	3/8" NPT-F	3/8" NPT-F	250 VAC	Brass	0.3 lbs.
100953	12.0 GPM	5800 PSI	180° F	3/8" NPT-F	3/8" NPT-F	250 VAC	SS	0.3 lbs.
100879	10.0 GPM	4000 PSI	180° F	3/8" NPT-F	3/8" NPT-F	250 VAC	Brass	1.5 lbs.
<i>With Pilot Feature</i>								
100904	10.0 GPM	4000 PSI	180° F	3/8" NPT-F	3/8" NPT-F	250 VAC	Brass	1.5 lbs.
<i>No Pilot Feature</i>								



**100934**



**100953**



**100879**

## Flow Switches

*Product Group: D*

	GPM	RATED	MAX	MAX TEMP	INLET	OUTLET	SHP WGHT
<i>3 amp, 230 Volts, 36" Cord (Mount in Vertical Position Only)</i>							
YFLOSWITCH	8.0 GPM	3650 PSI	4050 PSI	175° F	3/8" BSP-M	3/8" BSP-M	0.6 lbs.
<i>3 amp, 230 Volts, 48" Cord, Gauge Port</i>							
YFL3SWITCH	8.0 GPM	3650 PSI	4050 PSI	175° F	3/8" BSP-M	1/4" BSP-M	0.4 lbs.
<i>1 amp, 250 Volts, 48" Cord, Flow Through Design</i>							
YFL7SWITCH	8.0 GPM	5100 PSI		175° F	3/8" BSP-F	3/8" BSP-F	0.5 lbs.
<i>3 amp, 250 Volts 96" Cord (5 amp Max Carrying)</i>							
103011	.75 to 18.7 GPM	18 PSI	4000 PSI	165° F	3/8" NPT-F	3/8" NPT-F	2.5 lbs.
<i>3 amp, 250 Volts 96" Cord with Pilot Feature (5 amp Max. Carrying)</i>							
100329	.75 to 16.0 GPM	5000 PSI	5000 PSI	165° F	3/8" NPT-F	3/8" NPT-F	2.5 lbs.

**YFLOSWITCH**

**YFL7SWITCH**



**100329**

*Throttle Control for Gasoline Engines*

	RATED	MAX	INLET	SHP WGHT
ZSPEED	725 PSI	3000 PSI	3/8" NPT-M	1.1 lbs.



**ZSPEED**

# MISC. ACCESSORIES



**320001**

## Gauges (Glycerin Filled, Dual Scale)

*Product Group: D*

	PRESSURE	PORT	PORT LOCATION	SHP WGHT
320005	2000 PSI	1/4" NPT	Bottom Mount	0.7 lbs.
320000	3000 PSI	1/4" NPT	Bottom Mount	0.7 lbs.
320002	3000 PSI	1/4" NPT	Bottom Mount	0.7 lbs.
320001	5000 PSI	1/4" NPT	Panel Mount	0.7 lbs.
320003	5000 PSI	1/4" NPT	Bottom Mount	0.7 lbs.
320004	20000 PSI	1/2" NPT	Bottom Mount	1.0 lbs.



**190031**

## Valve Caps with Gauge Ports

*Product Group: D*

	DESCRIPTION	SHP WGHT
190029	Valve Cap with Gauge Port for 47 Series Pump	0.5 lbs.
190031	Valve Cap with Gauge Port for TT Series Pump	0.5 lbs.
190107	Valve Cap with Gauge Port for EZ Series Pump	0.5 lbs.
190358	Valve Cap with Gauge Port for 47 Series Pump, Fine Thread	0.5 lbs.

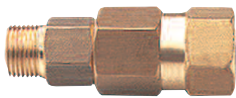

**YSW38MFB**

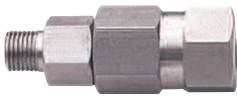

**YSW38MFSS**

## High-Pressure Swivels

*Product Group: H*

	DESCRIPTION	GPM	RATED	MAX	INLET	OUTLET	MAX TEMP	SHP WGHT
<i>Medium Resistance</i>								
YSW38MFB	Brass	10.5 GPM	3650 PSI	4050 PSI	3/8" BSP-M	3/8" BSP-F	320° F	0.3 lbs.
YSW14MFB	Brass	10.5 GPM	3650 PSI	4050 PSI	1/4" BSP-M	1/4" BSP-F	320° F	0.3 lbs.
YSW38MFSS	SS	10.5 GPM	5100 PSI	5650 PSI	3/8" BSP-M	3/8" BSP-F	320° F	0.3 lbs.
YSW14MFSS	SS	10.5 GPM	5100 PSI	5650 PSI	1/4" BSP-M	1/4" BSP-F	320° F	0.3 lbs.



**SW14MFN**



**SW38MF90N**

	DESCRIPTION	GPM	RATED	INLET	OUTLET	MAX TEMP	SHP WGHT
SW14MFN	Nickel Plated	12.0 GPM	1500 PSI	1/4" NPT-M	1/4" NPT-F	200° F	0.3 lbs.
SW38MF90N	Nickel Plated, 90° Elbow	12.0 GPM	1500 PSI	3/8" NPT-M	3/8" NPT-F	200° F	0.5 lbs.
SW38MFN	Nickel Plated	12.0 GPM	1500 PSI	3/8" NPT-M	3/8" NPT-F	200° F	0.3 lbs.
D10066	Brass	10.0 GPM	4000 PSI	3/8" NPT-M	3/8" NPT-F	200° F	0.3 lbs.
D10099	Brass	10.0 GPM	4000 PSI	3/8" NPT-F	3/8" NPT-F	200° F	0.3 lbs.
D10067	SST	10.0 GPM	5000 PSI	3/8" NPT-M	3/8" NPT-F	200° F	0.3 lbs.
D10070	SST, QD	10.0 GPM	5000 PSI	3/8" QD	3/8" QD plug	200° F	0.3 lbs.
D10071	Brass, Steel, QD	10.0 GPM	4000 PSI	3/8" QD	3/8" QD plug	200° F	0.3 lbs.
D10114	SS, 90° Elbow	10.0 GPM	3000 PSI	3/8" NPT-F	3/8" NPT-F	200° F	0.3 lbs.

## Complete Electric Pressure Washers

Product Group: E

FOR99SM	FORMULA 99 – Turbo 21 Aluminum Manifold, 1000 PSI	46.0 lbs.
190118	QUIKY – Turbo 21 Brass Manifold, Partial Plastic Enclosure, 1000 PSI with 10 meter Cord, GFCI and 36" Lance	53.0 lbs.
PU1021	BOXJET – Turbo 21 Aluminum Manifold, Complete Plastic Enclosure, 1000 PSI	52.0 lbs.
PU1021B	BOXJET – Turbo 21 Brass Manifold, Complete Plastic Enclosure, 1000 PSI	52.0 lbs.
PU1021QB	QUIKY – Turbo 21 Brass Manifold, Partial Plastic Enclosure, 1000 PSI	52.0 lbs.



**PU1021**

## Electric Pressure Washer Accessories

Product Group: N

ZOBOXCART	Cart Kit for Boxjet	13.0 lbs.
ZODRAINKIT	Boxjet Drain Kit with Hose	2.0 lbs.
ZOSANDKIT1	Boxjet Sandblasting Kit with Hose Poker	3.0 lbs.



**ZOSANDKIT1**

## Accumulators/Pulsation Dampeners

Product Group: K

	DESCRIPTION	GPM	RATED	INLET	SHP WGHT
ZMACC	Rebuildable	8.0 GPM	1350 PSI	3/4" NPT-M	0.5 lbs.
686028	Rechargeable	10.0 GPM	3000 PSI	1/2" NPT-M	2.5 lbs.
686011	Non-Rechargeable	10.0 GPM	3000 PSI	1/2" NPT-M	2.5 lbs.
*686010	Rechargeable	40.0 GPM	3000 PSI	1" NPT-M	7.0 lbs.

\*190200 Recharge Kit for 686010



**686010**

## Float Tank and Valve

Product Group: N

	DESCRIPTION	GPM	RATED	INLET	SHP WGHT	BOX QTY
YFLOATVALVE	Brass, Gray Float	7.0 GPM	145 PSI	3/8" BSP-M	0.8 lbs.	25
YRG60FV	Brass, Float	7.0 GPM	145 PSI	1/2" BSP	0.8 lbs.	25
YRG30FV	Plastic, Float	7.4/10.5 GPM	145 PSI	1/2" BSP-M	0.5 lbs.	25



**YRG30FV**

	DESCRIPTION	INLET	SHP WGHT	BOX QTY
YFLOATANK	1.05 Gallon Plastic Tank with Cover and Brass Float Valve	3/8" BSP-M	0.5 lbs.	12



**YFLOATANK**



**ZMSNDBLST1**

## Sandblasting Nozzles

*Product Group: N*

	DESCRIPTION	SHP WGHT
ZMSNDBLST0	1.5 mm/.059 Nozzle	2.5 lbs.
ZMSNDBLST1	1.6 mm/.063 Nozzle	2.5 lbs.
ZMSNDBLST2	1.7 mm/.067 Nozzle	2.5 lbs.
ZMSNDBLST3	1.85 mm/.073 Nozzle	2.5 lbs.
ZMSNDBLST4	2.1 mm/.083 Nozzle	2.5 lbs.
ZMSNDBLST5	2.3 mm/.091 Nozzle	2.5 lbs.

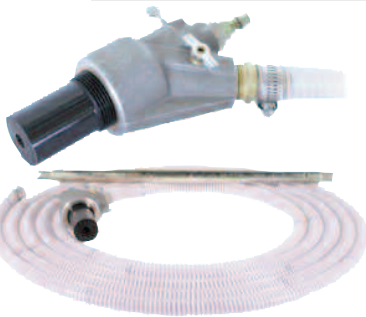

**DWSDBTK**

ZMSNDPOKER	Sand Poker	0.5 lbs.
------------	------------	----------

DWSDBTK	Complete wet industrial sandblast kit, 5500 PSI (1/4" nozzle not included)	10.0 lbs.
---------	--	-----------

2100206	Mixing Head, Sandblast	
2100208	Mixing Head and Nozzle, Sandblast	

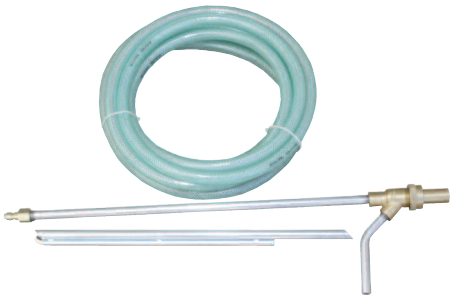

**DSDBK1**

DSDBK1	Complete sandblast kit, steel, brass, 3500 PSI	3.5 lbs.
--------	--	----------

## Service Products

*Product Group: Net*

KIT1S	Pump Service Video
KIT2S	Packing Insertion Kit and Pump Service Video
KIT3S	Packing Extraction Kit and Pump Service Video
KIT4S	Complete Tool Kit and Pump Service Video
KINSTX63	Packing Insertion Kit, 63 Series
KINSTSF66	Packing Insertion Kit for 66 Series, High Flow
KINSTSP66	Packing Insertion Kit for 66 Series, High Pressure
TOOLKITPRI	Complete Packing Replacement and Insertion Kit
ZMVALAT	Complete Tool Kit
ZMVT00L	Packing Insertion Tool

*Product Group: N*

26019400	Packing Extractor, Slide Hammer
27124900	Packing Extractor, 18 mm
26093400	Packing Extractor, Socket, 20 mm
26407400	Packing Extractor, 15 mm
26093500	Packing Extractor, Socket, 22 mm
26093600	Packing Insertion Socket, 24 mm



**100783 EXTRACTION KIT**

100783	Extraction Kit, 13 mm through 24 mm
--------	-------------------------------------

# WARRANTY INFORMATION

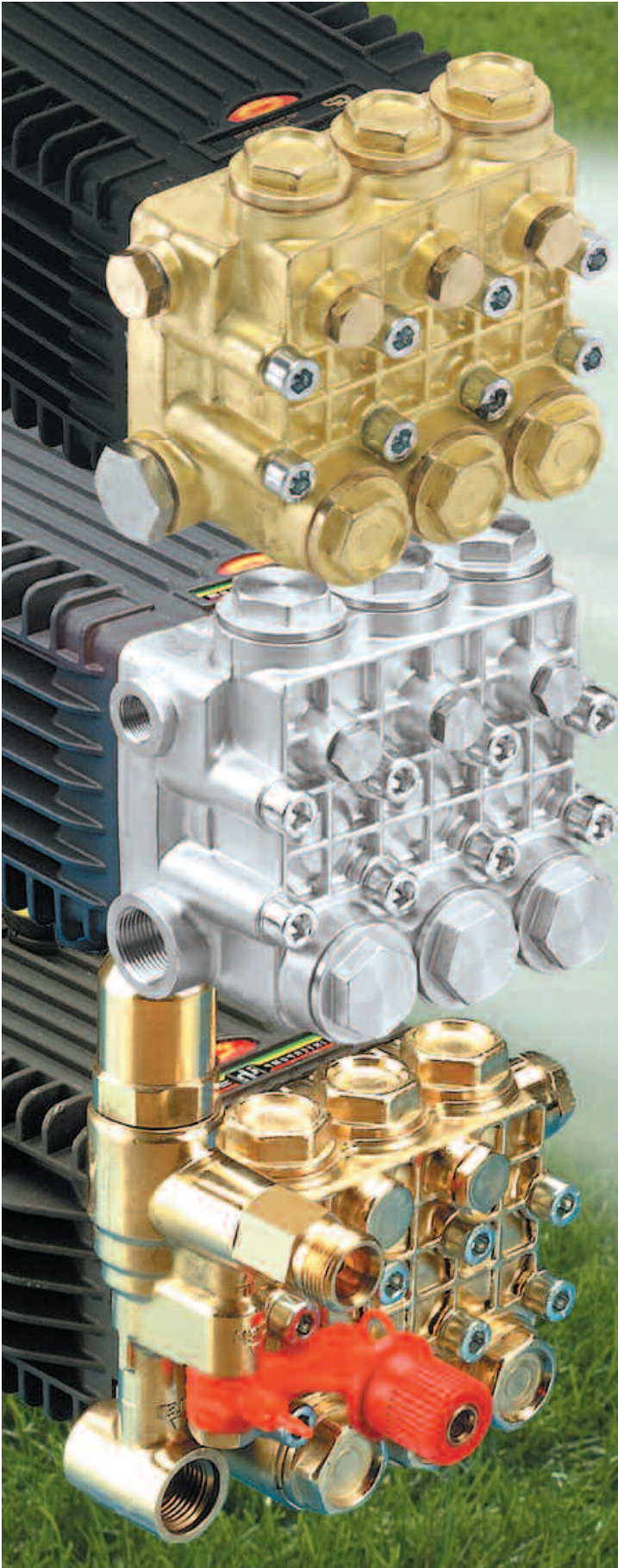

## **PUMP WARRANTY**

January 1, 2010

The following statement is intended to assist our customers in understanding the terms of our warranty, the circumstances under which we will honor claims, and the procedure for making such claims.

GP Companies, Inc. warrants each pump manufactured by General Pump to be free of defects in material or workmanship for a period of five (5) years from the date of shipment with the exception of TV/TH Series 57 Pumps, Consumer Pumps, the hydraulic pump line and the centrifugal pump line. In addition, GP Companies, Inc. warrants all forged brass pump manifolds to be free of defects in material and workmanship and from damage resulting from freezing for the life of the pump. Liability under this warranty is on all non-wear parts and limited to the repair or replacement of any pump returned to General Pump/US which upon inspection, is judged to be defective due to workmanship or material failure. You must display a Return Authorization Number obtained from our Inside Sales Department at (866)487-1778 or [custsvc@pwparts4less.com](mailto:custsvc@pwparts4less.com).



# WARRANTY INFORMATION

In the course of marketing or servicing the customer or potential customer's needs, General Pump will use its best judgement in its recommendations. However, the ultimate responsibility for product application decisions shall rest with the customer. The sole and only warranty made by General Pump is the limited warranty described above. General Pump makes no other warranty of any kind, express or implied, including any implied warranty or merchantability or of fitness for a particular use or purpose. General Pump disclaims and denies any liability for any direct, indirect, special, incidental or consequential damages which may be suffered as a result of sale, delivery, servicing, use, loss of any product, downtime, labor, freight or other charges not expressly included herein. The only liability and the total liability of General Pump under this limited warranty or in any claim regarding or involving General Pump is expressly limited to the replacement or purchase price of the product.



The following items are not warranted, due to matters beyond GP Companies, Inc. control.

- 1** Normal wear and tear to parts that are considered standard wear parts;
- 2** Defects caused by the fault or negligence of the buyer or third party;
- 3** Use of unauthorized repair parts;
- 4** Modifications made by the customer.
- 5** Car wash series pumps are covered for damage caused by fresh water wash out for the life of the pump.

This warranty statement supersedes and replaces non-dated warranties or previously dated warranties.

## **POWER UNIT(S) WARRANTY**

January 1, 2010

GP Companies, Inc. warrants each power unit in whole for 90 days from the date the unit is purchased. After 90 days, each pump manufactured by General Pump carries GP Companies, Inc. standard pump warranty. Each individual accessory on the power unit is covered by GP Companies, Inc. standard accessory warranty.

## **ACCESSORY WARRANTY**

January 1, 2010

GP Companies, Inc. accessories are warranted by the manufacturer to the original purchaser to be free from defects in material and workmanship

under normal use and service. "Normal use and service" means not in excess of the recommended pressures and temperatures or handling fluids not compatible with component materials. This warranty shall not apply to any accessory that has been repaired or altered to affect the performance or reliability of the accessory.

Warranty does not apply to:

- 1** freight damage;
- 2** freeze damage;
- 3** damage caused by parts and/or accessories not obtained from or approved by General Pump;
- 4** damage caused by misuse and/or misapplication;
- 5** normal wear of moving parts or components affected by moving parts

The period of the warranty is 90 days from the date the product is purchased. Liability of manufacturer under the foregoing warranty is limited to repair or replacement at the option of the manufacturer of that product, which according to the manufacturer's investigation was deemed defective at the time of the shipment.

This warranty is in lieu of all other warranties, expressed or implied, including any warranty of merchantability and/or any and all other obligations or liabilities on the part of the manufacturer.

Temperature Conversion Table							
°C	°F	°C	°F	°C	°F	°C	°F
100	212.0	75	167.0	50	122.0	25	77.0
99	210.2	74	165.2	49	120.2	24	75.2
98	208.4	73	163.4	48	118.4	23	73.4
97	206.6	72	161.6	47	116.6	22	71.6
96	204.8	71	159.8	46	114.8	21	69.8
95	203.0	70	158.0	45	113.0	20	68.0
94	201.2	69	156.2	44	111.2	19	66.2
93	199.4	68	154.4	43	109.4	18	64.4
92	197.6	67	152.6	42	107.6	17	62.6
91	195.8	66	150.8	41	105.8	16	60.8
90	194.0	65	149.0	40	104.0	15	59.0
89	192.2	64	147.2	39	102.2	14	57.2
88	190.4	63	145.4	38	100.4	13	55.4
87	188.6	62	143.6	37	98.6	12	53.6
86	186.8	61	141.8	36	96.8	11	51.8
85	185.0	60	140.0	35	95.0	10	50.0
84	183.2	59	138.2	34	93.2	9	48.2
83	181.4	58	136.4	33	91.4	8	46.4
82	179.6	57	134.6	32	89.6	7	44.6
81	177.8	56	132.8	31	87.8	6	42.8
80	176.0	55	131.0	30	86.0	5	41.0
79	174.2	54	129.2	29	84.2	4	39.2
78	172.4	53	127.4	28	82.4	3	37.4
77	170.6	52	125.6	27	80.6	2	35.6
76	168.8	51	123.8	26	78.8	1	33.8
						0	32.0

Temperature Conversion formulas      °C = 5/9(°F-32)    °F = 9/5(°C+32)

## Hose Friction Loss

Water* Flow Gal/Min	Pressure Drop in PSI per 100 feet of Hose With Typical Water Flow Rates						
	Hose Inside Diameters, Inches						
	1/4"	5/16"	3/8"	1/2"	5/8"	3/4"	1"
0.5	16	5	2				
1.0	54	20	7	2			
2.0	180	60	25	6	2		
3.0	380	120	50	13	4	2	
4.0		220	90	24	7	3	
5.0		320	130	34	10	4	
6.0			220	52	16	7	1
8.0			300	80	25	10	2
10.0				120	38	14	3
15.0				250	80	30	7
20.0					121	50	12
25.0					200	76	19
40.0					410	162	42
60.0						370	93

\*At a fixed flow rate with a given size hose, the pressure drop across a given hose length will be directly proportional. A 50 foot hose will exhibit one-half the pressure drop of a 100 foot hose. Above values shown are valid at all pressure levels.

Suction, Head, Vapor Pressure						
Temp °F	Vapor Pressure	Suction lift or head @ altitude ft				
		0	2000	4000	8000	12000
60	0.6 ft water	20	17.5	15.5	11.5	7.5
70	0.8 ft water	19.5	17	15	11	7
80	1.2 ft water	19.5	17	15	11	7
90	1.6 ft water	19	16.5	14.5	10.5	6.5
100	2.2 ft water	18.5	16	14	10	6
110	2.9 ft water	17.5	15	13	9	5
120	3.9 ft water	16.5	14	12	8	4
130	5.1 ft water	15.5	13	11	7	3
140	6.7 ft water	14	11.5	9.5	5.5	1.5
150	8.6 ft water	12	9.5	7.5	3.5	-0.5
160	10.9 ft water	9.5	7	5	1	...
170	13.8 ft water	6.5	4	2	-2	...
180	17.3 ft water	3	0.5	-1.5	...	...
190	21.6 ft water	-1	-3.5	-5.5	...	...
200	26.6 ft water	-6	-8.5	...	...	...
210	32.6 ft water	-12	...	...	...	...
212	34.0 ft water	-13.5	...	...	...	...

$$\text{GPM} = \frac{\text{HP} \times 1460}{\text{PSI}}$$

$$\frac{\text{Rated GPM}}{\text{Rated RPM}} = \frac{\text{Desired GPM}}{\text{Desired RPM}}$$

$$\text{PSI} = \frac{\text{HP} \times 1460}{\text{GPM}}$$

$$\frac{\text{Motor Pulley OD}}{\text{Pump RPM}} = \frac{\text{Pump Pulley OD}}{\text{Motor RPM}}$$

$$\text{Torque} = \frac{\text{HP} \times 5252}{\text{RPM}}$$

$$\text{Drive Ratio} = \frac{D}{d}$$

Friction Loss in Pipe Fittings in Equivalent Feet of Pipe							
Fitting	Fitting Size						
	1/2"	3/4"	1"	1-1/4"	1-1/2"	2"	2-1/2"
90° Std Elbow	1.6	2.1	2.6	3.5	4	5.5	6.2
90° Long Elbow	1	1.4	1.7	2.3	2.7	4.3	5.1
90° Street Elbow	3	3.4	4.4	5.8	6.7	8.6	10.3
45° Std Elbow	0.8	1.1	1.4	1.8	2.1	2.8	3.3
45° Street Elbow	1	1.8	2.3	3	3.5	4.5	5.4
Square Elbow	3	3.9	5	6.5	7.6	9.8	11.7
Std Tee Straight Run	1	1.4	1.7	2.3	2.7	4.3	5.1
Std Tee Branch Run	4	5.1	6	6.9	8.1	12	14.3
Gate Valve - Full Open	0.7	0.9	1.1	1.5	1.7	2.2	2.7



## Nozzle Chart

Nozzle Size	Orifice Dia.	40 PSI	100 PSI	250 PSI	500 PSI	600 PSI	700 PSI	800 PSI	1000 PSI	1200 PSI	1500 PSI	2000 PSI	2500 PSI	3000 PSI	3500 PSI	4000 PSI	5000 PSI
2	.034	0.20	0.32	0.50	0.71	0.77	0.84	0.89	1.00	1.10	1.22	1.41	1.58	1.73	1.87	2.00	2.24
2.5	.039	0.25	0.40	0.63	0.88	0.97	1.05	1.12	1.25	1.37	1.53	1.77	1.98	2.17	2.34	2.50	2.80
3	.043	0.30	0.47	0.75	1.06	1.16	1.25	1.34	1.50	1.64	1.84	2.12	2.37	2.60	2.81	3.00	3.35
3.25	.045	0.33	0.51	0.81	1.15	1.26	1.36	1.45	1.63	1.78	1.99	2.30	2.57	2.81	3.04	3.25	3.63
3.5	.048	0.35	0.55	0.88	1.24	1.26	1.46	1.57	1.75	1.92	2.14	2.47	2.77	3.03	3.27	3.50	3.91
3.75	.050	0.38	0.59	0.94	1.33	1.45	1.57	1.68	1.88	2.05	2.30	2.65	2.96	3.25	3.51	3.75	4.17
4	.052	0.40	0.63	1.00	1.41	1.45	1.67	1.79	2.00	2.19	2.45	2.83	3.16	3.46	3.74	4.00	4.47
4.5	.055	0.45	0.71	1.13	1.59	1.74	1.88	2.01	2.25	2.46	2.76	3.18	3.56	3.90	4.21	4.50	5.03
5	.057	0.50	0.79	1.25	1.77	1.94	2.09	2.24	2.50	2.74	3.06	3.54	3.95	4.33	4.68	5.00	5.59
5.5	.060	0.55	0.87	1.38	1.94	2.13	2.30	2.46	2.75	3.01	3.37	3.89	4.35	4.76	5.14	5.50	6.15
6	.062	0.60	0.95	1.50	2.12	2.32	2.51	2.68	3.00	3.29	3.67	4.24	4.74	5.20	5.61	6.00	6.71
6.5	.064	0.65	1.03	1.63	2.30	2.52	2.72	2.91	3.25	3.56	3.98	4.60	5.14	5.63	6.08	6.50	7.27
7	.067	0.70	1.11	1.75	2.47	2.71	2.93	3.13	3.50	3.83	4.29	4.95	5.53	6.06	6.55	7.00	7.83
7.5	.070	0.75	1.19	1.88	2.65	2.90	3.14	3.35	3.75	4.11	4.59	5.30	5.93	6.50	7.02	7.50	8.39
8	.072	0.80	1.26	2.00	2.83	3.10	3.35	3.58	4.00	4.38	4.90	5.66	6.32	6.93	7.48	8.00	8.94
8.5	.074	0.85	1.34	2.13	3.01	3.29	3.56	3.80	4.25	4.66	5.21	6.01	6.72	7.36	7.95	8.50	9.50
9	.076	0.90	1.42	2.25	3.18	3.49	3.76	4.02	4.50	4.93	5.51	6.36	7.12	7.79	8.42	9.00	10.06
9.5	.078	0.95	1.50	2.38	3.36	3.68	3.97	4.25	4.75	5.20	5.82	6.72	7.51	8.23	8.89	9.50	10.62
10	.080	1.00	1.58	2.50	3.54	3.87	4.18	4.47	5.00	5.48	6.12	7.07	7.91	8.66	9.35	10.00	11.18
11	.083	1.10	1.74	2.75	3.89	4.26	4.60	4.92	5.50	6.02	6.74	7.78	8.70	9.53	10.29	11.00	12.30
12	.087	1.20	1.90	3.00	4.24	4.65	5.02	5.37	6.00	6.57	7.35	8.49	9.49	10.39	11.22	12.00	13.42
12.5	.089	1.25	1.98	3.13	4.42	4.84	5.23	5.59	6.25	6.85	7.65	8.84	9.88	10.83	11.69	12.50	13.98
13	.091	1.30	2.06	3.25	4.60	5.03	5.44	5.81	6.50	7.12	7.96	9.19	10.28	11.26	12.16	13.00	14.53
14	.093	1.40	2.21	3.50	4.95	5.42	5.86	6.26	7.00	7.67	8.57	9.90	11.07	12.12	13.10	14.00	15.65
15	.096	1.50	2.37	3.75	5.30	5.81	6.27	6.71	7.50	8.22	9.19	10.61	11.86	12.99	14.03	15.00	16.77
20	.109	2.00	3.16	5.00	7.07	7.75	8.37	8.94	10.00	10.95	12.25	14.14	15.81	17.32	18.71	20.00	22.36
25	.125	2.50	3.95	6.25	8.84	9.68	10.46	11.18	12.50	13.69	15.31	17.68	19.76	21.65	23.39	25.00	27.95
30	.141	3.00	4.74	7.50	10.61	11.62	12.55	13.42	15.00	16.43	18.37	21.12	23.72	25.98	28.06	30.00	33.54
40	.156	4.00	6.32	10.00	14.14	15.49	16.73	17.89	20.00	21.91	24.49	28.28	31.62	34.64	37.42	40.00	44.72
50	.172	5.00	7.91	12.50	17.68	19.36	20.92	22.36	25.00	27.39	30.62	35.36	39.53	43.30	46.77	50.00	55.90
60	.188	6.00	9.49	15.00	21.21	23.24	25.10	26.83	30.00	32.86	36.74	42.43	47.43	51.96	56.12	60.00	67.08

GP Nozzle Spray Coverage

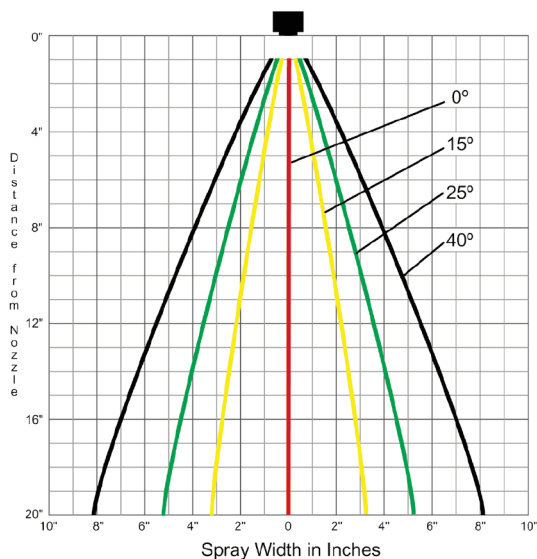

### Nozzles

Nozzle # =	GPM	$\sqrt{\frac{4000 \cdot \text{PSI}}{\text{GPM}^2}}$
GPM =	Nozzle #	$\sqrt{\frac{\text{PSI}}{4000}} \cdot \text{GPM}$
PSI =	$\left(\frac{\text{GPM}}{\text{Nozzle}}\right)^2 \cdot 4000$	4000

### Horsepower

$\frac{\text{GPM} \cdot \text{PSI}}{1460}$	=	Electric Brake HP
$\frac{\text{GPM} \cdot \text{PSI}}{1714}$	=	Hydraulic HP
$\frac{\text{GPM} \cdot \text{PSI}}{1460} \cdot 1.5$	=	Gasoline HP (Industrial Engine)

# Trust General Pump

Don't risk failure by trusting the imposters.



Trusting “will-fit” parts and kits can result in failure in critical situations. Why take that risk? Always look for GENUINE General Pump parts, kits and nozzles.



**MK Series**  
40-107 GPM,  
2175-5800 PSI  
160 EBHP

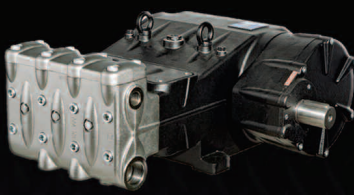

**VF Series**  
3-6 GPM,  
11600-21750 PSI  
50 EBHP



**KFM Series**  
30.0 GPM,  
1500 PSI

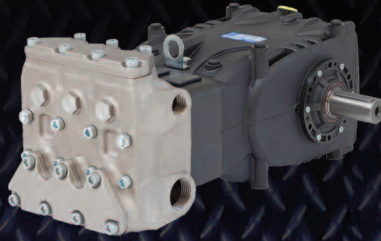

**KE Series**  
8-18 GPM,  
1885-4350 PSI  
25 EBHP



**KF Series**  
24-45 GPM,  
1600-3045 PSI  
50 EBHP

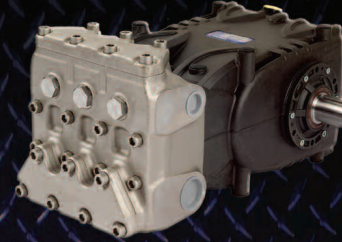

**HF Series**  
8-19 GPM,  
4060-8700 PSI  
50 EBHP



**SK Series**  
11.4-25.9 GPM,  
10150-21750 PSI  
168-180 EBHP



**LK Series**  
37-111.7 GPM,  
2320-5800 PSI  
145-176 EBHP

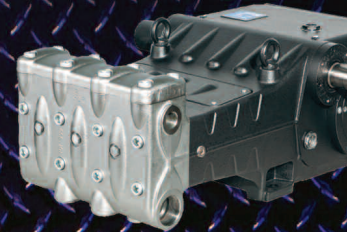

**MKS Series**  
48-128.5 GPM,  
2100-5800 PSI  
185 EBHP



**KS Series**  
24-60 GPM,  
2000-4000 PSI  
75 EBHP

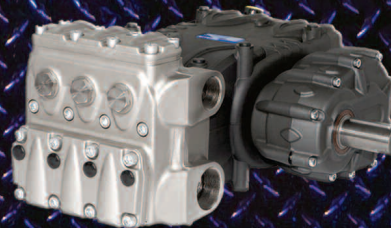

# THE NEW GENERATION

Longer Life, Easier Installation, Lower Operating Costs

## Special Applications?

No problem. General Pump offers an endless variety of custom-built skid mounted pump systems.

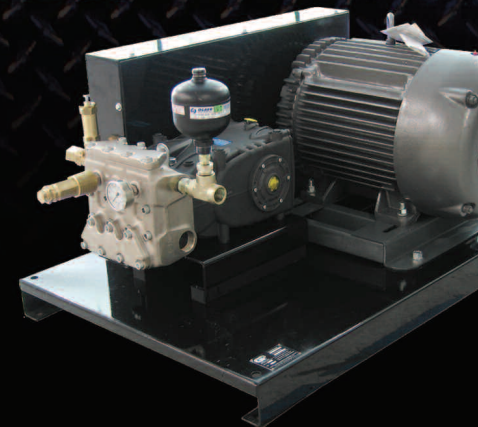
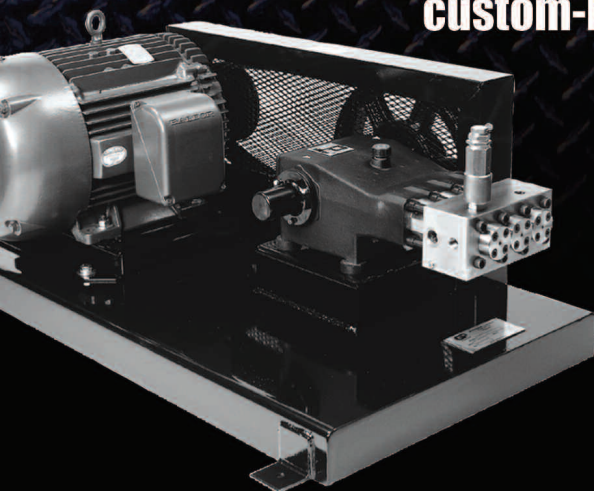

GENERAL PUMP

# STAINLESS STEEL PUMPS FROM GENERAL PUMP



**GENERAL PUMP**