

FW VERSION - ROLLER BEARINGS - 1450 RPM

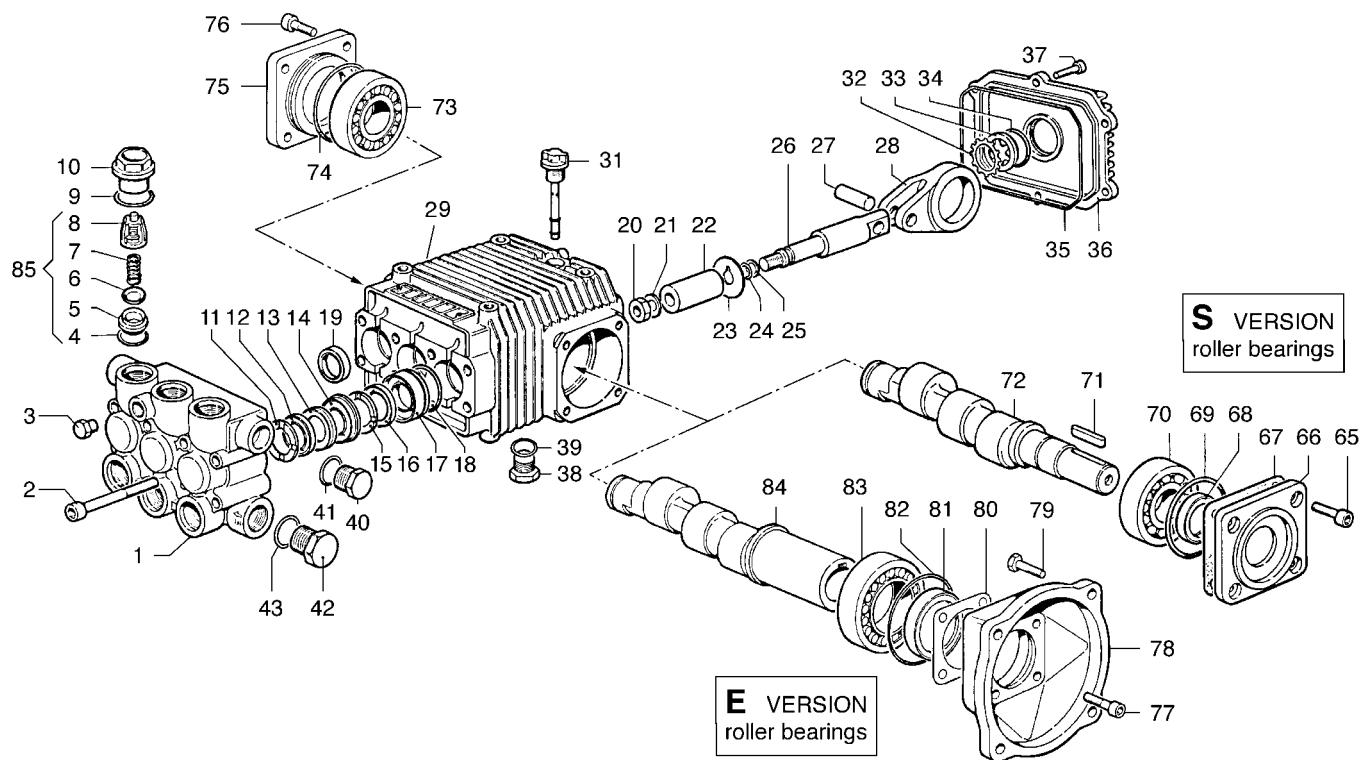

ITEM	PART No.	KIT	DESCRIPTION	Qty.	MODELS
1	3218.0109.00		MANIFOLD Ø20 mm	1	5023 S - 5023 E 5030 S - 5522 S 5522 E - 5526 S 5530 S
	3218.0110.00		MANIFOLD Ø 18 mm	1	3016 S - 3525 S 3525 E - 3530 S 3530 E - 4030 S 4030 E
2	3609.0039.00		SCREW M8X70	8	
3	3202.0112.00		CAP G1/4	1	
4	1210.0046.00	A-D	O-RING 2,62X 17,13 mm	6	
5	3009.0087.00	A	VALVE SEAT	6	
6	3604.0017.00	A	VALVE PLATE	6	
7	1802.0177.00	A	SPRING	6	
8	1205.0025.00	A	VALVE CAGE	6	
9	1210.0048.00	A-D	O-RING 2,62X 20,24 mm	6	
10	3202.0155.00		CAP	6	
11	0009.0108.00	B	HEAD RING Ø20 mm	3	5023 S - 5023 E 5030 S - 5522 S 5522 E - 5526 S 5530 S
	0009.0199.00	B	HEAD RING Ø18 mm	3	3016 S - 3525 S 3525 E - 3530 S 3530 E - 4030 S 4030 E
12	1241.0032.00	B	PACKING Ø20 mm	3	5023 S - 5023 E 5030 S - 5522 S 5522 E - 5526 S 5530 S
	1241.0026.00	B	PACKING Ø18 mm	3	3016 S - 3525 S 3525 E - 3530 S 3530 E - 4030 S 4030 E
13	0009.0104.00	B	PACKING Ø20 mm	3	5023 S - 5023 E 5030 S - 5522 S 5522 E - 5526 S 5530 S
	0009.0100.00	B	PACKING Ø18 mm	3	3016 S - 3525 S 3525 E - 3530 S 3530 E - 4030 S 4030 E

ITEM	PART No.	KIT	DESCRIPTION	Qty.	MODELS
14	0009.0114.00		INTERMED. RING Ø20 mm	3	5023 S - 5023 E 5030 S - 5522 S 5522 E - 5526 S 5530 S
	0009.0200.00		INTERMED. RING Ø18 mm	3	3016 S - 3525 S 3525 E - 3530 S 3530 E - 4030 S 4030 E
15	0009.0108.00	B	HEAD RING Ø20 mm	3	5023 S - 5023 E 5030 S - 5522 S 5522 E - 5526 S 5530 S
	0009.0199.00	B	HEAD RING Ø18 mm	3	3016 S - 3525 S 3525 E - 3530 S 3530 E - 4030 S 4030 E
16	1241.0032.00	B	PACKING Ø 20 mm	3	5023 S - 5023 E 5030 S - 5522 S 5522 E - 5526 S 5530 S
	1241.0026.00	B	PACKING Ø 18 mm	3	3016 S - 3525 S 3525 E - 3530 S 3530 E - 4030 S 4030 E
17	0009.0106.00		PACKING RETAINER Ø20 mm	3	5023 S - 5023 E 5030 S - 5522 S 5522 E - 5526 S 5530 S
	0009.0102.00		PACKING RETAINER Ø18 mm	3	3016 S - 3525 S 3525 E - 3530 S 3530 E - 4030 S 4030 E
18	1210.0156.00	B-D	O-RING 1,78X31,47 mm	3	
19	0019.0066.00	D	OIL SEAL 20X30X5 mm	3	
20	0600.0054.00	C	NUT	3	
21	2811.0082.00	C	WASHER 8,2X17X1,5 mm	3	
22	0202.0024.00	C	PISTON Ø20 mm	3	5023 S - 5023 E 5030 S - 5522 S 5522 E - 5526 S 5530 S
	0202.0022.00	C	PISTON Ø18 mm	3	3016 S - 3525 S 3525 E - 3530 S 3530 E - 4030 S 4030 E

FW VERSION - ROLLER BEARINGS - 1450 RPM

ITEM	PART No.	KIT	DESCRIPTION	Qty.	MODELS
23	2812.0042.00	C	WASHER	3	
24	1210.0039.00	C-D	O-RING 1,78X 7,66 mm	3	
25	0009.0170.00	C-D	ANTI-EXTR. RING	3	
26	2409.0048.00		PISTON GUIDES	3	
27	3011.0016.00		WRIST. PIN Ø10X29 mm	3	
28	0205.0044.00		CON. ROD	3	
29	0403.0129.00		CRANKCASE	1	3016 S - 3527 S 3525 S - 3530 S 4030 S - 5023 S 5030 S - 5522 S 5526 S - 5530 S
	0403.0130.00		CRANKCASE	1	3525 E - 3530 E 4030 E - 5023 E 5522 E
31	3200.0051.00		OIL DIPSTICK	1	
32	3019.0033.00		SNAP RING Ø18 mm	1	
33	3201.0012.00		OIL INDICATOR	1	
34	1210.0333.00	D	O-RING 1,78X23,52 mm	1	
35	1210.0216.00	D	O-RING 2,62X107,62 mm	1	
36	0402.0169.00		CRANCKCASE COVER	1	
37	3609.0030.00		SCREW M5X20	6	
38	3200.0007.00		CAP 3/8 GAS	1	
39	1210.0441.00	D	O-RING 2x14 mm	1	
40	3200.0007.00		CAP 3/8 GAS	1	
41	2811.0084.00		WASHER 16,7X22X1,5 mm	1	
42	3202.0015.00		CAP G1/2	1	
43	2811.0086.00		WASHER 21,2X27X1,5 mm	1	
73	0440.0012.00		ROLLER BEARING	2	
74	1210.0388.00	D	O-RING	1	
75	0402.0171.00		FLANGE	1	
76	3609.0032.00		SCREW M6X20	4	
85	1220.0030.00		VALVE ASS. BLY.	6	

S version

ITEM	PART No.	KIT	DESCRIPTION	Qty.	MODELS
65	3609.0058.00		SCREW M8X22	4	
66	0402.0170.00		FLANGE	1	
67	0601.0218.00		SHIM Ø62 0,05 mm	1	
	0601.0220.00		SHIM Ø62 0,10 mm	1	
	0601.0222.00		SHIM Ø62 0,19 mm	1	
	0601.0259.00		SHIM Ø62 0,25 mm	1	
68	0019.0007.00	D	OIL SEAL 25X52X7 mm	1	
69	1210.0388.00	D	O-RING	1	
70	0440.0012.00		ROLLER BEARING	1	
71	1602.0013.00		KEY 8X7X30 mm	1	
72	0001.0323.00		CRANKSHAFT Ø24 mm	1	5522 S - 5526 S 5530 S
	0001.0324.00		CRANKSHAFT Ø24 mm	1	3525 S - 3530 S
	0001.0325.00		CRANKSHAFT Ø24 mm	1	4030 S - 5023 S 5030 S
	0001.0345.00		CRANKSHAFT Ø24 mm	1	3016 S

E version

ITEM	PART No.	KIT	DESCRIPTION	Qty.	MODELS
77	3609.0058.00		SCREW M8X22	4	
78	3016.0015.00		FLANGE	1	
79	3607.0026.00		SCREW M8X25	4	
80	0601.0210.00		SHIM Ø68 0,05 mm	1	
	0601.0212.00		SHIM Ø68 0,10 mm	1	
	0601.0214.00		SHIM Ø68 0,19 mm	1	
	0601.0216.00		SHIM Ø68 0,25 mm	1	
81	0019.0052.00	D	OIL RING 40X52X7 mm	1	
82	1210.0109.00	D	O-RING 1,78X 63,22 mm	1	
83	0440.0011.00		ROLLER BEARING 40X68X19	1	
84	0001.0326.00		CRANKSHAFT Ø28 mm	1	3525 E - 3530 E
	0001.0328.00		CRANKSHAFT Ø28 mm	1	4030 E - 5023 E
	0001.0349.00		CRANKSHAFT Ø28 mm	1	5522 E

COMPLETE VALVE KIT
5025.0011.00

KIT A

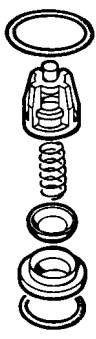

POS. ITEM	CODICE PART No.	Q.tà Qty.
4	1210.0046.00	6
5	3009.0087.00	6
6	3604.0017.00	6
7	1802.0177.00	6
8	1205.0025.00	6
9	1210.0048.00	6

PISTON SEAL KIT
Ø 18 mm 5019.0038.00 - Ø 20 mm 5019.0039.00

KIT B

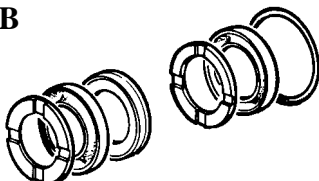

5019.0038.00			5019.0039.00		
POS. ITEM	CODICE PART No.	Q.tà Qty.	POS. ITEM	CODICE PART No.	Q.tà Qty.
11	0009.0199.00	3	11	0009.0108.00	3
12	1241.0026.00	3	12	1241.0032.00	3
13	0009.0100.00	3	13	0009.0104.00	3
15	0009.0199.00	3	15	0009.0108.00	3
16	1241.0026.00	3	16	1241.0032.00	3
18	1210.0156.00	3	18	1210.0156.00	3

PISTON KIT
Ø 18 mm 2409.0073.00 - Ø 20 mm 2409.0074.00

KIT C

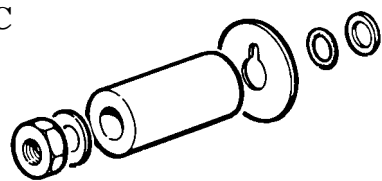

2409.0073.00			2409.0074.00		
POS. ITEM	CODICE PART No.	Q.tà Qty.	POS. ITEM	CODICE PART No.	Q.tà Qty.
20	0600.0054.00	3	20	0600.0054.00	3
21	2811.0082.00	3	21	2811.0082.00	3
22	0202.0022.00	3	22	0202.0024.00	3
23	2812.0042.00	3	23	2812.0042.00	3
24	1210.0039.00	3	24	1210.0039.00	3
25	0009.0170.00	3	25	0009.0170.00	3

5019.0044.00			5019.0045.00		
POS. ITEM	CODICE PART No.	Q.tà Qty.	POS. ITEM	CODICE PART No.	Q.tà Qty.
4	1210.0046.00	6	4	1210.0046.00	6
9	1210.0048.00	6	9	1210.0048.00	6
18	1210.0156.00	3	18	1210.0156.00	3
19	0019.0066.00	3	19	0019.0066.00	3
24	1210.0039.00	3	24	1210.0039.00	3
25	0009.0170.00	3	25	0009.0170.00	3
34	1210.0333.00	1	34	1210.0333.00	1
35	1210.0216.00	1	35	1210.0216.00	1
39	1210.0441.00	1	39	1210.0441.00	1
68	0019.0007.00	1	74	1210.0388.00	1
69	1210.0388.00	1	81	0019.0052.00	1
74	1210.0388.00	1	82	1210.0109.00	1

SEAL KIT
SOLID SHAFT 5019.0044.00
HOLLOW SHAFT 5019.0045.00

KIT D

