

FEATURES

- Innovative one-piece plunger design to eliminate water entering crankcase
- 5% reduction in crankcase load compared to standard 3,000 psi – 15 mm pumps
- Superior plunger performance against thermal shock and cavitation due to new, unique bonding process
- Standard 24 mm solid shaft for pulley mounting
- Forged brass manifold with an exclusive lifetime warranty and 3:1 hydrostatic rating
- Die-cast, anodized aluminum, oil-bath crankcase
- Premium roller bearing
- Unitized stainless steel inlet and discharge valves
- Available in “L” left-handed versions

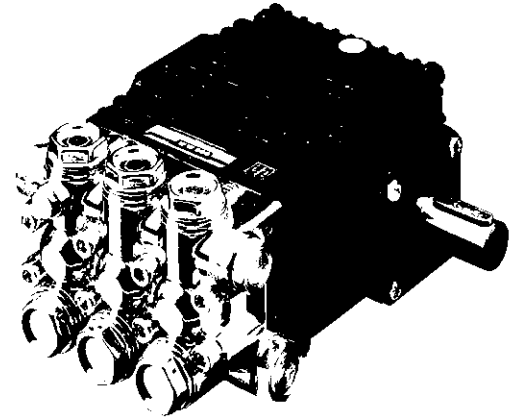

SPECIFICATIONS

Pump Model	EZ4040S34	EZ4035S34	EZ4030S34
Maximum Volume	4.0 GPM	3.5 GPM	3.0 GPM
Maximum Discharge Pressure	4000 PSI		
Maximum Pump Speed	3400 RPM		
Maximum Inlet Pressure	125 PSI		
Maximum Inlet Vacuum	Flooded		
Bore	.512 in. / 13 mm		
Stroke (in./mm)	.512 / 13	.433 / 11	.374 / 9.5
Crankcase Oil Capacity	14.0 oz.		
Maximum Fluid Temperature	165°F		
Inlet Port Thread	1/2-14 BSPP-F		
Discharge Port Thread	3/8-19 BSPP-F		
Shaft Diameter	.945 in. / 24 mm		
Weight	18 lbs.		
Dimensions	8.6 x 8.7 x 5.5 in.		

EZ Series 44 S – Solid Shaft **GENERAL PUMP** A member of the Interpump Group

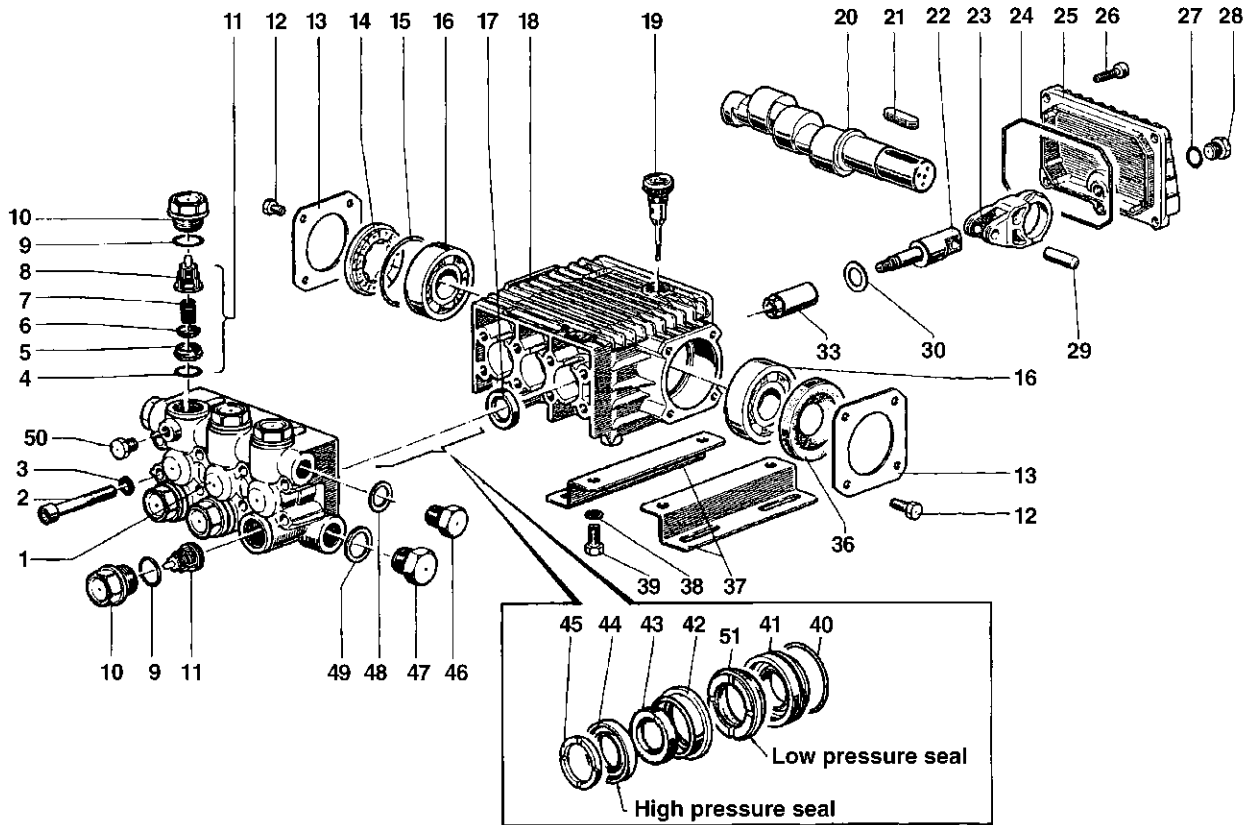

PARTS LIST

Item	Part No.	Description	Kit No.	Qty.	Item	Part No.	Description	Kit No.	Qty.	Item	Part No.	Description	Kit No.	Qty.
1.	44.1206.41	Manifold		1	17.	90.1614.00	Oil Seal	23	3	36.	90.1641.00	Oil Seal		1
2.	99.3175.00	Screw		8	18.	44.0100.22	Crankcase		3	37.	50.2000.74	Rail		2
3.	96.7014.00	Washer		8	19.	98.2103.00	Oil Dip Stick		1	38.	96.7016.00	Washer		4
4.	90.3841.00	O-Ring	123	6	20.	44.0206.35	Crankshaft (EZ4040S34)		1	39.	99.3037.00	Nut		4
5.	36.2003.66	Valve Seat	123	6		44.0203.35	Crankshaft (EZ4035S34)			40.	90.3612.00	O-Ring	152, 156	3
6.	36.2001.76	Valve	123	6		44.0200.35	Crankshaft (EZ4030S34)			41.	44.0803.70	Packing Retainer	152, 156	3
7.	94.7376.00	Spring	123	6	21.	91.4892.00	Key		1	42.	44.2162.70	Intermediate Ring	154, 156	3
8.	36.2025.51	Valve Cage	123	6	22.	44.0501.66	Piston Guide		3	43.	90.5076.00	Packing	153, 156	3
9.	90.3847.00	O-Ring	124	6	23.	44.0300.22	Connecting Rod		3	44.	90.2602.00	Packing	153, 156	3
10.	98.2226.00	Cap Screw	124	6	24.	90.3920.00	O-Ring		1	45.	44.1002.51	Head Ring	155, 156	3
11.	36.7115.01	Valve Assembly	123	6	25.	44.1600.22	Rear Cover		1	46.	98.2100.00	Cap Screw		1
12.	99.1807.00	Screw		8	26.	99.1837.00	Screw		5	47.	98.2176.00	Cap Screw		1
13.	50.1500.74	Bearing Cover		2	27.	90.3585.00	O-Ring		1	48.	96.7380.00	Washer		1
14.	44.2118.01	Spacer		1	28.	98.2041.00	Cap Screw		1	49.	96.7514.00	Washer		1
15.	90.4097.00	O-Ring		1	29.	97.7340.00	Pin		3	50.	98.1966.00	Cap Screw		1
16.	91.8328.00	Ball Bearing		2	30.	96.6967.00	Washer		3	51.	90.2603.00	Seal, Low Pressure	153, 156	3
					33.	44.0402.66	Plunger, 13 mm		3					

REPAIR KITS

KIT NO.	23	123	124	152	153	154	156
ITEM NO's INCLUDED IN KIT	17	4, 5, 6, 7, 8, (11)	9, 10	40, 41	43, 44, 51	42	40, 41, 42, 43, 44, 45, 51
NUMBER OF ASSEMBLIES IN KIT	3	6	6	3	3	3	1
NUMBER OF CYLINDERS KIT WILL SERVICE	3	3	3	3	3	3	1

TORQUE SPECS*

Position	Ft.-lbs.	N-M
2	14.7	20
10	73.7	100
12	7.3	10
26	7.3	10
28	14.7	20
33	6.6	9
46	29.4	40
47	29.4	40
50	9.6	13

*Decrease torque by 20% if threads are lubricated.