

KOHLER ENGINE ACCESSORIES

Capitalizing on performance and reliability.

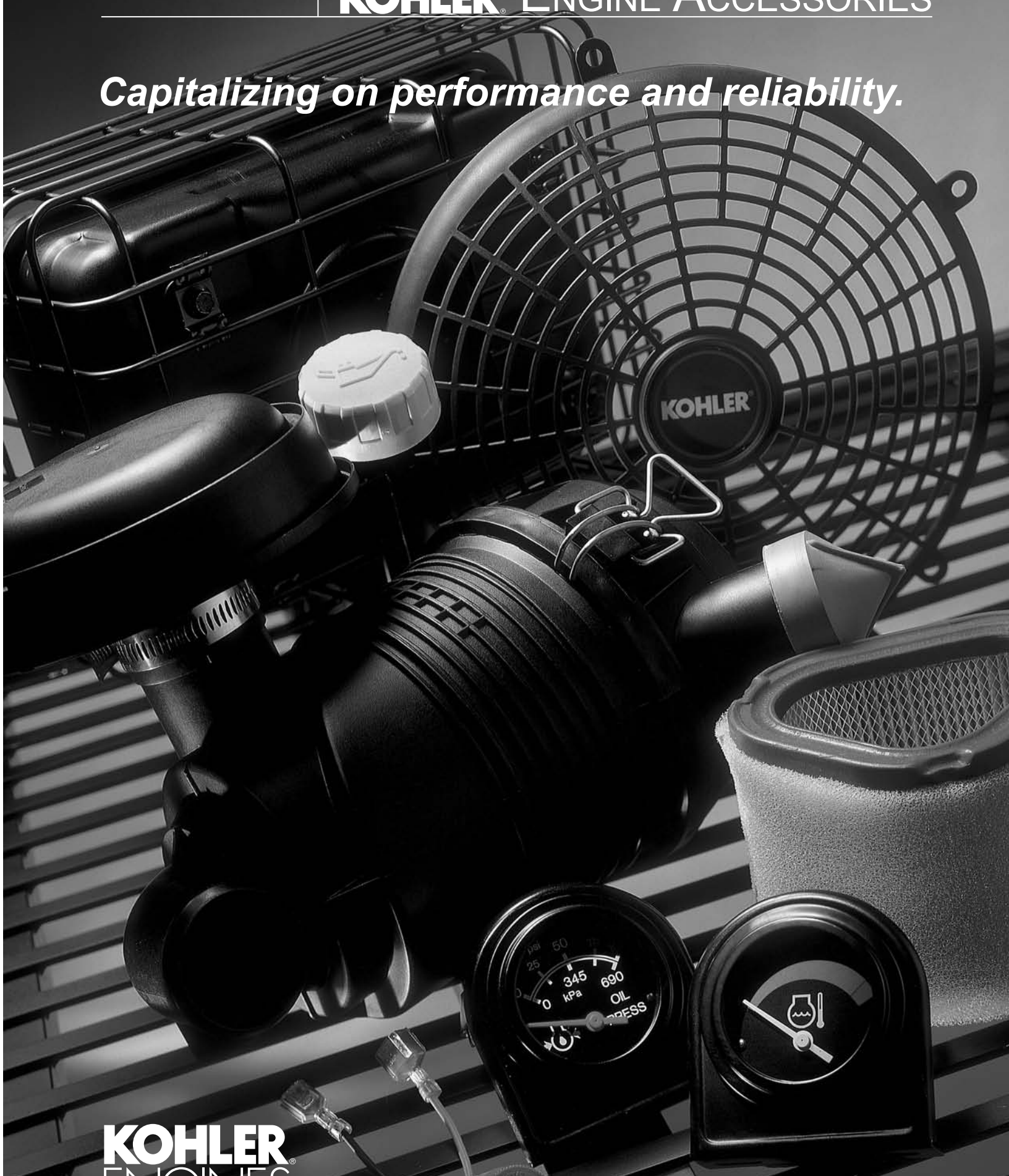

KOHLER
ENGINES

2008 Edition

Contents

Table of Contents

SECTION	PAGE
Central Distributors – North America	3
Central Distributors – International	3
Engine Model Lines	4-5
Lubrication	6-8
Starting	9
Meters & Special Tools	10
Special Items	11
Ignition and Electrical	12-14
Guards, Screens, and Blower Housings.....	15-17
Front Drive Shafts.....	18
Fuel.....	19-21
Controls	
(Includes coolant and lubrication alert items)	22-24
Electrical Accessories.....	25
Air Intake	26-32
Exhaust.....	33-46
Labels.....	47-53
Hang Tags and Cards.....	54



Kohler central distributors are listed on this page. They...and all Kohler dealers...can quickly provide the field-installed accessories in this catalog to keep your KOHLER® engines running smoothly and efficiently.

UNITED STATES

STATE/PROVINCE	KOHLER CENTRAL DISTRIBUTOR	CITY	PHONE
Arizona	Loftin Equipment Co., Inc.	Phoenix	602-272-9466
California	H. G. Makelim Co.	Anaheim	650-873-4757
	H. G. Makelim Co.	S. San Francisco	650-873-4757
Colorado	H. G. Makelim Co.—Denver	Aurora	303-307-8874
Florida	Gardner of Florida, Inc.	Jacksonville	888-889-3010
Hawaii	Small Engine Clinic	Aiea	808-488-0711
Kansas	Medart—Kansas City	Edwardsville	636-282-2300
Massachusetts	W.J. Connell Co.	Franklin	508-543-3600
Minnesota	Central Power Distributors, Inc.	Anoka	763-576-0901
Mississippi	Medart—Tennessee/Mississippi	Olive Branch, MS	636-282-2300
Missouri	Medart—St. Louis	St. Louis	636-282-2300
Montana	Original Equipment, Inc.	Billings	406-245-3081
New Jersey	Gardner, Inc.—New Jersey	Cranbury	609-860-8060
Ohio	Gardner, Inc.—Ohio	Columbus	614-456-4000
Oregon	Power Equipment Systems	Salem	800-782-2700
Pennsylvania	Pitt Auto Electric Co.	Cranberry Township	724-778-8200
Tennessee	Medart—Tennessee/Mississippi	Olive Branch, MS	636-282-2300
Texas	Waukesha-Pearce Industries, Inc.	Houston	713-723-1050
Utah	Diesel Electric Service & Supply Co., Inc.	Salt Lake City	801-972-1836
Virginia	Chesapeake Engine Distributors	Ashland	804-550-2231
Wisconsin	Central Power Distributors, Inc.	Menomonee Falls	262-250-1977

CANADA

Alberta	Lotus Equipment Sales, Ltd.	Calgary	403-253-0822
British Columbia	Magneto Sales	Surrey	604-888-7240
Manitoba	Yetman's Ltd.	Winnipeg	204-586-8046
Ontario	CPT—Canada Power Technology	Mississauga	905-890-6900

INTERNATIONAL ~ Visit the Dealer Locator: www.KohlerEngines.com

The Growing Family of KOHLER Engines

SINGLE CYLINDER



Courage® 4.5 HP
Air-cooled, vertical, OHV
Models: XT-7



Courage® 15-22 HP
Air-cooled, vertical, OHV
Models: SV470, 480, 530, 540, 590, 600, 610, 620

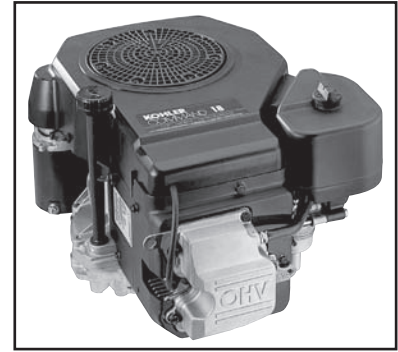

Command® 13-18 HP
Air-cooled, vertical, OHV
Models: CV13, 15, 460, 490, 492

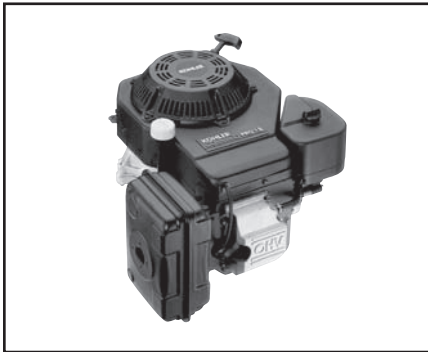

Command PRO® 13-18 HP
Air-cooled, vertical, OHV
Models: CV13, 15, 493



Command PRO® CS 4-12.75 HP
Air-cooled, horizontal, OHV
Models: CS4, 6, 8.5, 10, 12



Command PRO® 11-15 HP
Air-cooled, horizontal, OHV
Models: CH15, 410, 430, 450

TWIN CYLINDER



KOHLER Courage® 20-27 HP
Air-cooled, vertical, OHV
Models: SV710, 715, 720, 730, 735, 740

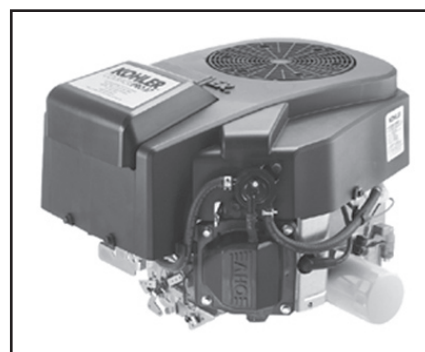

KOHLER Courage PRO® 20-27 HP
Air-cooled, vertical, OHV
Models: SV810, 820, 830, 840



KOHLER Aegis® 20-24 HP
Liquid-cooled, vertical, OHV
Models: LV625, 680

The Growing Family of KOHLER Engines



KOHLER Aegis® 24-31 HP
Liquid-cooled, horizontal, OHV
Models: LH640, 690, 755, 775 EFI



Command PRO® 34-40 HP
Air-cooled, horizontal, OHV
Models: CH940, 960, 980, 1000



Command PRO® 34-40 HP
Air-cooled, vertical, OHV
Models: CV940, 960, 980, 1000



Command PRO® 17-30 HP
Air-cooled, vertical, OHV
Models: CV17, 18, 22, 25, 26, 730, 740,
745 EFI, 750



Command PRO® 18-30 HP
Air-cooled, horizontal, OHV
Models: CH18, 20, 22, 25, 26, 730, 740,
745 EFI, 750



Command® 18-27 HP
Air-cooled, horizontal, OHV
Models: CH18, 20, 22, 620, 640, 680, 730, 740



Command® 18-27 HP
Air-cooled, vertical, OHV
Models: CV18, 20, 22, 730, 740

Lubrication



OIL COOLER KIT

To add cooler to engine. Reduces oil sump temperature up to 40°F.

Kit No.	Adapter Material	Models
24 755 120-S*	Stanyl	CH/CV17-26/730-750

*Increases engine width on oil filter side by 1.25" (CH twins) or 0.625" (CV twins).

OIL COOLER HOSE

Part No.	Length	I.D.
24 326 17-S*	140mm (5-1/2")	9.52mm (3/8")

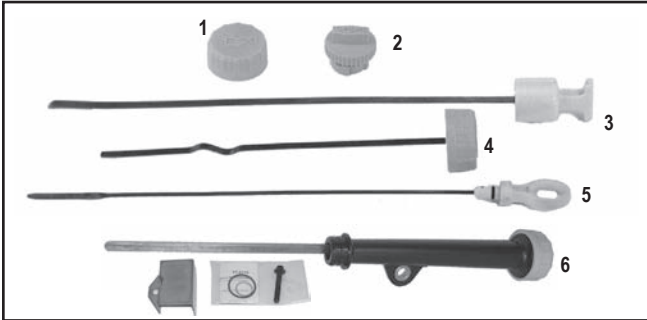

YELLOW ACCESSORIES

Part No.	Item	Models	
24 755 46-S*	Oil fill cap kit	CH18-26/730-750, LH640-775	1
24 227 02-S**	Oil fill cap Assy	CH18-26/730-750, LH640-775	2
12 038 10-S	Dipstick, bent tube	CH11-15	3
12 038 14-S	Dipstick, straight tube	CH11-15	3
12 038 02-S	Dipstick, straight tube	CV11-16/460-493	4
24 038 04-S	Dipstick, straight tube	CV17-26/730-750	4
66 038 01-S	Dipstick, bent tube	LV625-680	4
24 038 10-S***	Dipstick, bent/straight tube	CH18-26/730-750, LH640-775	5
20 040 02-S****	Dipstick, bent tube (Standard)	SV470-610	-
24 123 22-S****	Dipstick, tube kit (plastic)	CH18-26/730-750, LH640-775	6

*For valve cover with pulse-type fuel pump, not mechanical fuel pump. Includes o-ring.

**For valve cover with mechanical fuel pump. Includes o-ring.

***Used with flared tube for improved seal. Standard since Serial No. 3016800011. Earlier standard dipstick 24 038 06-S superseded to 24 755 121-S Kit which includes the 24 038 10-S dipstick and three dipstick tubes to fit all CH twin configurations.

****Can be used in place of the 1" diameter metal oil fill/dipstick tube for improved seal. Can be used with standard canister-style mufflers. Do not use on applications with crossover manifolds.



OIL DRAIN VALVE KIT

Part No.	Drain Hole	Models
25 755 14-S	3/8"-18 NPTF	All Models*

Includes 25 173 14-S yellow plastic cap.

*For CH6, also order 15 158 02-S bushing which adapts 3/8" NPT valve to 1/2" NPT engine drain.

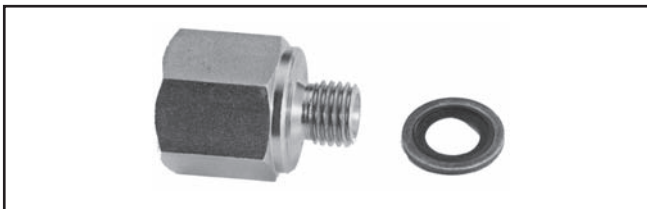

OIL DRAIN ADAPTER

For use with 25 755 14-S Oil Drain Valve Kit (3/8"-18). Includes seal.

Part No.	Thread, Engine End	Thread, Cap End	Models
63 755 11-S*	M10-1.25, Male	1/8"-27, Female	CS4-6
63 755 10-S	M12-1.5, Male 2	3/8"-18, Female	CS8.5-12

*Customer must furnish a 1/8"-27 straight pipe (to extend away from engine), and a 3/8"-18 x 1/8"-27 reducer coupling for attaching pipe to Valve Kit.



OIL DRAIN HOSE

For use with 25 755 14-S Oil Drain Valve Kit (3/8"-18).

Part No.	Length	Thread	Models
24 326 59-S*	7"	3/8"-18, Male (both ends)	All
24 326 66-S**	12.25"	3/8"-18, Female (one end)	All
25 326 05-S**	28"	3/8"-18, Female (one end)	All

*Also order 25 249 01-S Female Coupling for attaching hose to Valve Kit.

**Also order 24 294 22-S Barbed Fitting and 25 237 02-S Clamp for attaching hose to oil drain hole.



OIL FILTERS

Part No.	Height	Models	Item
25 050 34-S	3.47"	SV810-840 PRO	1
52 050 02-S	3.47"	CH11-15 PRO, SV470-610 CV13-15/493 PRO, SV710-740, CH/CV18-26/730-745 PRO, LV625-675, LH640-775	2
12 050 01-S	2.72"	CV11-16/460-492, SV470-610, CH/CV17-25/730-740, SV710-740, TH520-575	3
28 050 01-S*	2.32"	TH520-575	4

*Shorter for applications with interference issues. Approx. 15% less filter capacity.



VALVE COVER WITH OIL FILL

Ideal for adding an extra oil fill location.

Part No.	Description	Models
24 755 140-S*	Valve cover with oil fill**	CH18-26/730-745
66 755 10-S*	Valve cover with oil fill***	LH640-775

* Usable on either valve cover side, except for basic engines which include a mechanical fuel pump (with oil fill) in filter side valve cover.

** Also order 24 755 46-S yellow cap/o-ring assembly, or 25 755 13-S black cap/o-ring assembly.

***Includes yellow cap, o-ring, etc.



REMOTE OIL FILTER

Kit No.	Oil Line Length	Models
24 702 02-S*	23"	CH/CV11-16/460-493, SV470-610, CH/CV17-26, CH/CV730-750, LV625-675, SV710-740

*Includes 12 050 01-S Filter.



OIL FILTER BASE (ENGINE-MOUNTED)

Part No.	Position	Extends	Models
24 702 01-S*	Rotatable, 6 positions	3-4"	CH/CV17-22, LV625-680

* Not usable on specs with oil cooler. Includes 12 050 01-S filter.

Lubrication

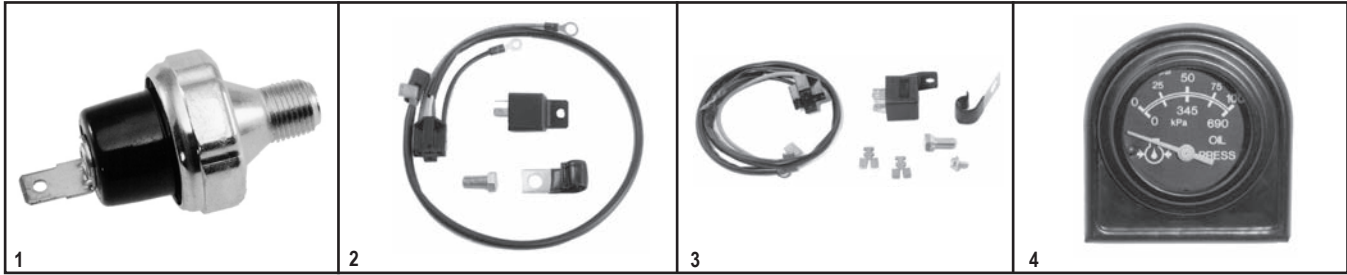

OIL PRESSURE SWITCH (OIL SENTRY™)

Available on electric start engines only.

Part No.	Circuit	PSI To Activate	Models	Item
12 704 01-S*	Normally Closed	2-5	CH/CV11-16/460-493	1
52 704 01-S*	Normally Closed	2-5	CH/CV17-26/730-745, LV625-680	1
25 099 03-S	Normally Closed	2-5	CH/CV17-26/730-745, SV810-840	1
25 099 27-S	Normally Closed	2-6	LH640-775 (Standard on basics)	1

*Kit includes switch, other components and instructions.

OIL PRESSURE BYPASS KITS

Allows for momentary bypass of oil pressure switch when electric starter is engaged.

Part No.	Circuit	Models	Item
82 755 25-S	Normally Closed	CH11-15*, CH/CV17-26/730-745, CH/CV940-1000, LV625-680, LH640-775	2
25 743 05-S	Normally Open**	CH/CV14 LP**	3

*Usable on CH11-15, except with solenoid shift starter. Became standard on CH11-15 PRO electric start basics beginning with serial no. 3208409911.

**Usable on any engine where the fuel system valve is controlled by a "normally open" oil pressure switch, typically found on gaseous fuel engines.

OIL PRESSURE GAUGE KIT

Includes sender that mounts to oil filter base, gauge holder/hardware for mounting on top of engine-mounted control panel. (See "CONTROLS" section.)

Part No.	Pressure Range	Models	Item
66 755 13-S	0-100 psi (0-690 kPa)	LH640-775	4

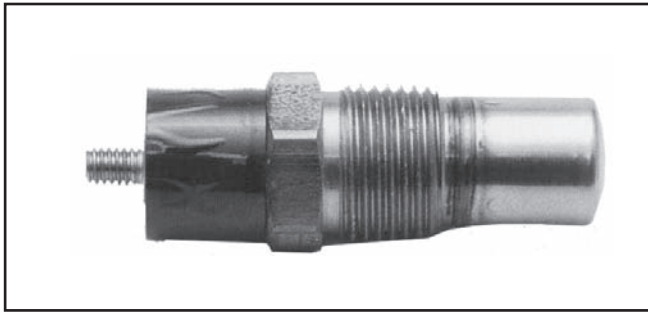

OIL TEMPERATURE SENSOR

Fits into oil drain hole to signal when temperature exceeds recommended range.

Part No.	Open	Closed	Models
24 418 01-S (standard)	310°F	350°F	CH/CV17-26*/730-745, LV625-680, LH640-775
24 418 02-S	255°F	310°F	CH/CV17-26*/730-745, LV625-680, LH640-775

*On CV specs, use on starter side only. Filter side has oil cooler.



OIL WARNING LIGHTS

Part No.	Notes	Lead Length	Models
25 704 05-S*	Non-mobile equipment	6"	TH520-575
12 704 02-S**	'S' or 'ST'	6"	CH/CV11-16/460-493
25 352 06-S	Need 15 176 03-S harness	3"	CH5-6
25 352 10-S***	—	6.5", 9"	CH18-26/730-745
25 352 12-S***	—	6.5", 9"	LH640-775

* Includes light plus other parts not necessarily needed.

** Includes light, pressure switch, wiring, etc.

***Usable in panel kits. (See "CONTROL PANEL" page).

ALSO SEE PAGE 22 FOR COOLANT AND LUBRICATION ALERT ITEMS.

ROPE START PULLEY KITS

Kit No.	Models
12 755 46-S	CH11-15

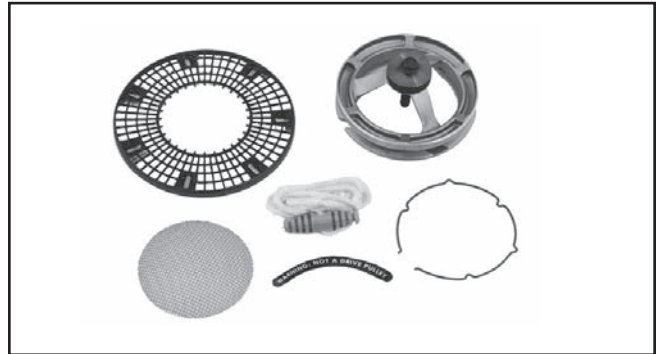

RECOIL START KITS

Kit No.	Models
12 755 47-S	CH/CV11-16/460-493 (Shown)
25 312 01-S	
12 165 02-S	

Notes
 For metal blower housings only.
 Optional mitt grip handle for recoil starter.
 Recoil starter assembly with mitt grip handle.



ELECTRIC START KITS

Kit No.	Models
12 749 02-S	CH11-15 (Shown)
12 749 03-S	CV11-16/460-493

(Excludes wire harness which customer must supply due to variations.)



STARTER SOLENOIDS

Part No.	Description	Models
25 435 02-S*	Internally grounded	CH/CV11-16/460-493

*Water resistant



Meters, Testers, and Special Tools

ALCOHOL CONTENT TESTER & METERS



Item	Description	Models	Item
25 455 11-S	Alcohol Content Tester - Tests for E10/E20/E85	All	1
25 449 05-S*	Usage Meter/Tachometer (solid state)	All singles & twins	2
25 761 23-S	EFI Diagnostic Kit (includes CD-ROM to diagnose engine)	All EFI	3
52 362 01-S	Hourmeter	All with electric start	4

*Indicates when to service air cleaner, oil filter and change oil. Also serves as an hour meter and tachometer. Service intervals are dependent upon environmental factors and not this meter alone.

SPECIAL TOOLS

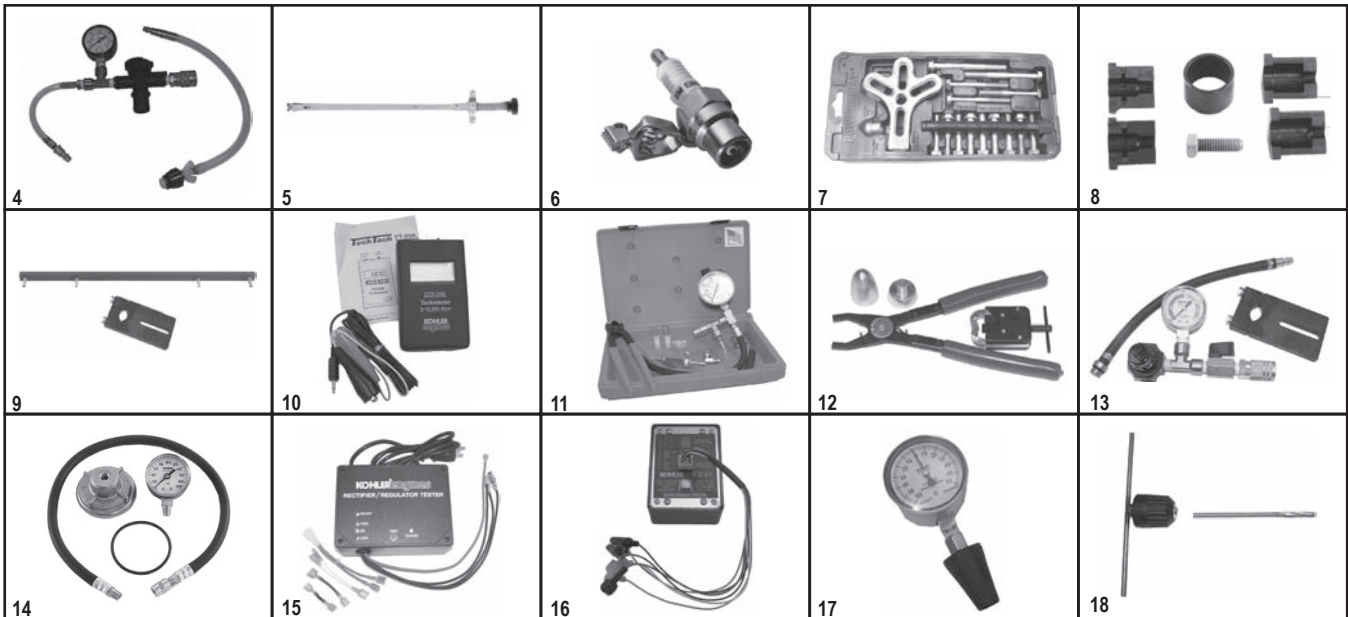

Part No.	Description	Models	Item
25 455 10-S*	Radiator and Cap Tester	Liquid Cooled Models	4
25 761 38-S	Hydraulic Valve Lifter Tool	All with hydraulic lifters	5
24 455 02-S	Ignition Output Tester (capacitive discharge, fires at 18kV)	All twin cylinder	6
25 455 01-S	Ignition Output Tester (all except capacitive discharge, fires at 12kV)	All single cylinder	6
KLR-82408**	Flywheel Puller Set	All	7
25 761 18-S	Starter Snap-Ring Set (inertia drive starters)	All except Magnum twins and CS	8
28 761 01-S	OHC Timing Tool Set (timing belt)	All OHC	9
DTI-110**	Inductive Tachometer	All except battery ignition	10
24 761 01-S	EFI Service Tool Kit (for individual components see Parts Bulletin 228)	All EFI	11
KLR-82411**	Electric Starter Service Kit	All	12
25 761 05-S	Cylinder Leakdown Tester	All	13
25 761 06-S	Oil Pressure Test Kit	All w/pressure lubrication	14
25 761 20-S	Rectifier/Regulator Tester (operates on 110-120 volt current)	All	15
25 761 41-S	Rectifier/Regulator Tester (operates on 220-240 volt current)	All	15
25 761 40-S	Spark Advance Module Tester	All w/spark advance module	16
25 761 22-S	Vacuum/Pressure Tester	All	17
25 455 09-S	T-Handle for Valve Guide Reimer (below)	All	18
25 455 12-S	0.25mm Oversized Reimer for Valve Guides	Command and Aegis (11 HP)	18

*Designed to work with item #13 (25 761 05-S) or requires a regulated air supply.

**Available from Kohler-recommended tool supplier, see Parts Bulletin 228.

ALSO SEE PAGE 22 FOR COOLANT AND LUBRICATION ALERT ITEMS.

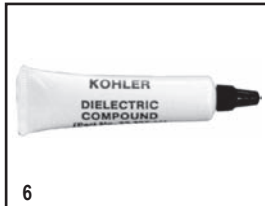

OIL, SEALANT, LUBRICANT

Part No.	Description	Fl. Size	For	Item
25 357 06-S	SAE 10W-30 KOHLER® Oil	32 oz.	All OHV/OHC Engines	1
25 357 03-S	SAE 30 KOHLER® Oil	32 oz.	XT-7 Engines	2
25 357 14-S	Lubricant, Camshaft/Lifter	0.25 oz.	—	3
52 357 01-S	Lubricant, Inertia Drive Starter	0.25 oz.	—	4
52 357 02-S	Lubricant, Solenoid Shift Starter	0.25 oz.	—	4
25 357 12-S	Lubricant, Spline Drive	2.8 oz.	All	5
25 357 11-S	Grease, Dielectric	0.25 oz.	All except EFI	6
25 597 07-S	Sealant (Loctite Instant Gasket)	4 oz.	All RTV Applications	7

MAINTENANCE KITS

Everything needed for periodic preventative maintenance, in a handy display pack.

Part No.	Models
20 789 01-S	SV470-620
12 789 01-S	CV11-15, 460, 490, 492
12 789 02-S	CV11-15, 460-493 PRO
24 789 01-S	CV17-23, 724-740; CH18-25, 730-740
24 789 02-S	CV18-30, 675-740; CH18-25, 730-750 PRO
24 789 03-S	CV17-27, 730-740 WAWB
25 789 01-S	CV18-25, 625-750; CH18-25, 730-750 HDAC
32 789 01-S	SV710-740



PLASTIC NUT

Part No.	Hardware Size
24 100 37-S	6mm



BAFFLE MOUNTING CLIP

Part No.	Hardware Size
25 154 02-S	6mm



Ignition and Electrical



RFI/EMI CONVERSION KIT

Kit No. 25 707 01-S
Models All CH, CV, LH, LV, SV Twins



DIODE KIT

Part No. 25 755 31-S
Specifications 5 AMP 800PIV
Models All

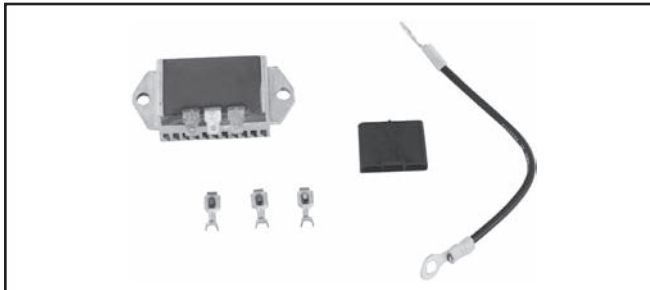

CHARGING SYSTEMS

Part No.	Description	Models
15 Amp 237878-S	Stator Kit	CH/CV11-16/460-493, SV470-620, CH/CV17-26/730-745, LH640-775, LV625-685, SV710-740
41 403 09-S	Rectifier-Regular	All
25 Amp 28 085 02-S	Stator Kit	CH/CV11-16/460-493, SV470-620
54 755 03-S	Stator/Rectifier-Regular Kit*	CH/CV17-26/730-745, TH520-575, LH640-775, LV625-675, SV710-740
24 755 144-S	Rectifier-Regular Kit**(Shown)	

* Converts 15 amp system to 25 amp.
 **Converts old 25 amp rectifier-regular (25 403 01-S or 25 403 04-S) to new 25 amp rectifier-regular (25 403 05-S) on all models. Includes rectifier-regular, terminals (3), lead, connector block.



SPARK PLUGS

Part No.	Models
66 132 01-S	LH640-775, LV625-680, CS4-12.75 (Champion)
12 132 02-S	CH6, CH/CV11-15/460-492, CH/CV17-30/730-750, CH20-25 LP, TH520-575, TH520-575 LP, XT-7
25 132 12-S	CH/CV11-15/493 PRO, CH/CV18-30/730-750 PRO
25 132 08-S	CH/CV11-15 LP
28 132 01-S	CH/CV17-25/730-740 R.F.I. with shielded metal boots
28 132 02-S	TH520-575 R.F.I.
25 132 14-S	SV470-620 R.F.I., SV710-840 R.F.I., LV625-680 R.F.I., LH640-755 R.F.I., CH/CV17-25/730-740 R.F.I. w/o metal boots
62 132 04-S	CH940-1000 R.F.I.,

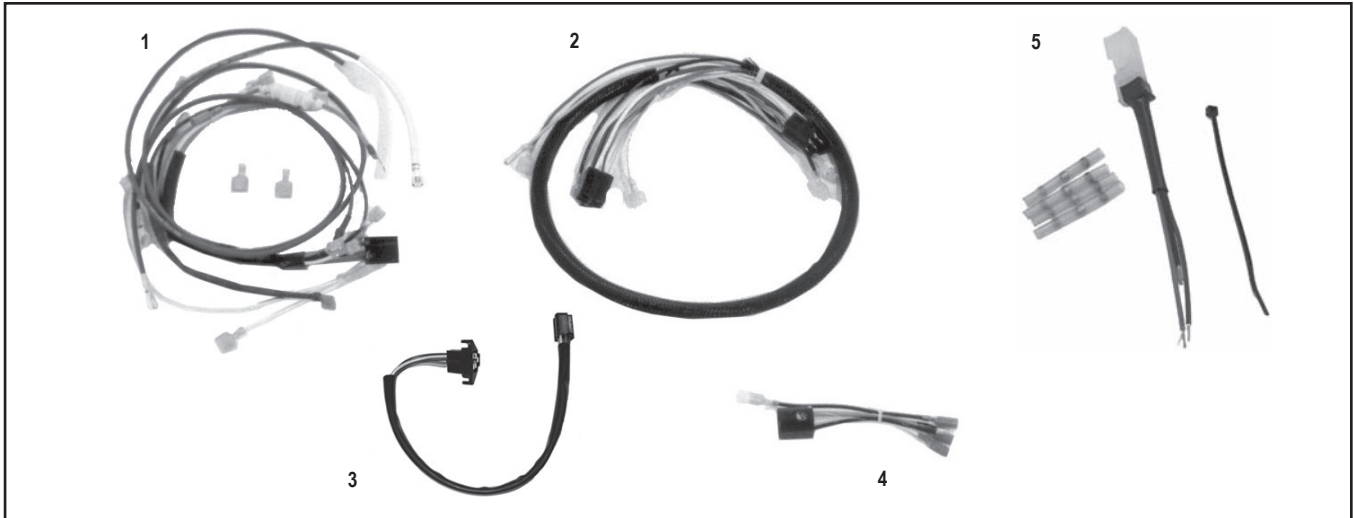

WIRING HARNESSSES

Part No.	No. Leads	Lead Length	Connector	Models	Item
54 755 02-S	*	34" longest	Numerous	CH/CV17-25/730-740	1
66 176 18-S	8**	36" longest	25 155 06 (Female), 48 155 01 (Male)	LH640-755	2
52 155 08-S	2	18" all	52 155 04 (Female)	Various	3
52 155 09-S	3	18" all	237088 (Female)	Various (shown)	3
25 155 07-S	5	18" all	25 155 06 (Female)	Various	3
25 155 09-S	5	18" all	25 155 06 (Female), 48 155 01 (Male)	Various	3
25 176 02-S	6***	75" longest	25 155 06 (Female), 48 155 01 (Male)	C11-16/460-493, C17-25/730-740	3
25 176 10-S	6***	75" longest	25 155 06 (Female), 48 155 01 (Male)	LH640-755, LV625-680	3
63 176 01-S	6****	5" longest	48 155 01 (Male)	CH/CV940-1000	4
24 755 155-S	*****	4" longest		CS8.5-12	5
62 176 10-S	4	30" longest	Molex #33482-0401 (Male)	CH/CV940-1000	Not Pictured
62 176 11-S	4	3-7/8"	Molex #33482-0401 (Male), 6 Pin Packard	CH/CV940-1000	Not Pictured

* Includes universal harness, duplex lead harness, Oil Sentry™ lead, 20 amp B+ lead, 25 amp B+ lead with Connector 25 155 03-S, (2) Terminals 15 452 10-S, and instructions.

** Can be used as a general 36" extension to basic wire harness.

*** Includes equipment ground lead for between keyswitch and engine block.

**** Used to create remote-mount keyswitch (use Keyswitch 25 099 04-S). Also order Harness 25 176 02-S above.

*****Pigtail harness used to replace diagnostic plug. Includes protective cap, 24 139 06-S.



SEALED FUSE HARNESS/HOLDER

Part No.	Models
54 755 13-S	All

Converts standard harness/fuse holder to a sealed version to prevent moisture, dirt, etc., from penetrating. Ideal for pressure washers or applications in corrosive environment. Includes 30 amp fuse.

Ignition and Electrical

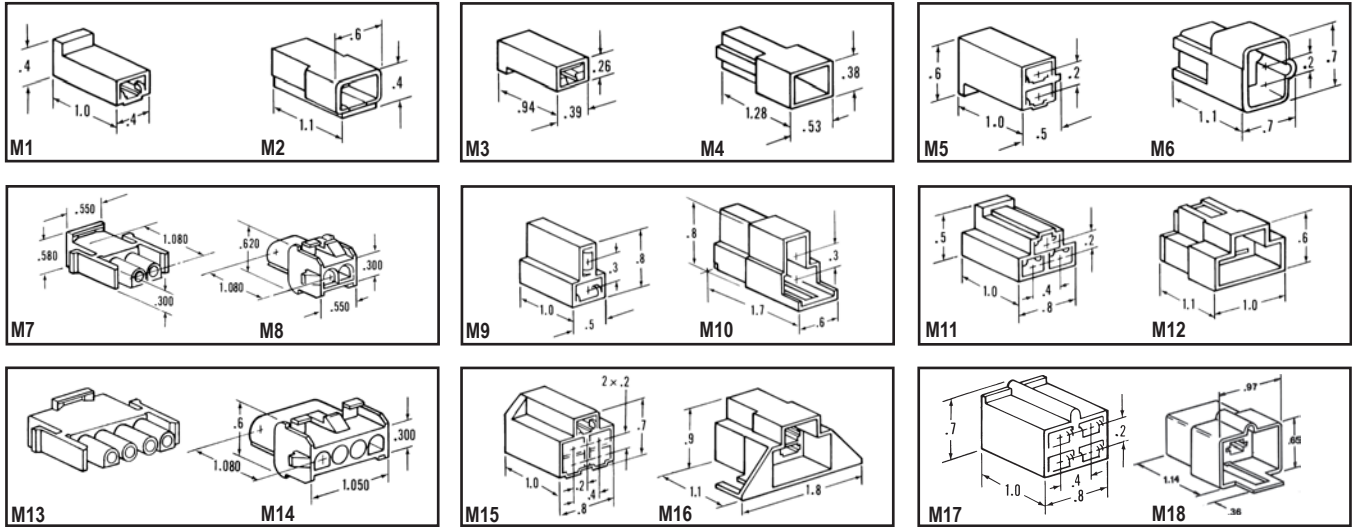

MATED (M) CONNECTORS

Description	Connector Item	Connector Part No.	Uses Female Terminal (See Below)	Connector Item	Connector Part No.	Uses Male Terminal (See Below)
1 Wire	M1	277563-S	Item 5, 6	M2	15 155 01-S	Item 4
1 Wire	M3	25 155 04-S	Item 5, 6	M4	25 155 03-S	—
2 Wire	M5	41 155 03-S	Item 5, 6	M6	52 155 04-S	Item 4
2 Wire	M7	47 155 14-S	—	M8	47 155 13-S	—
2 Wire	M9	48 155 02-S	Item 5, 6	M10	48 155 03-S	Item 4
3 Wire	M11	236473-S	Item 5, 6	M12	237088-S	Item 4
4 Wire	M13	12 155 03-S	—	M14	12 155 02-S	—
5 Wire	M15	48 155 01-S	Item 5, 6	M16*	25 155 06-S	Item 4
4 Wire	M17	41 155 02-S	Item 5, 6	M18	12 155 10-S	Item 4

*Mounting screw slots on M16 are 1.328" center to center.

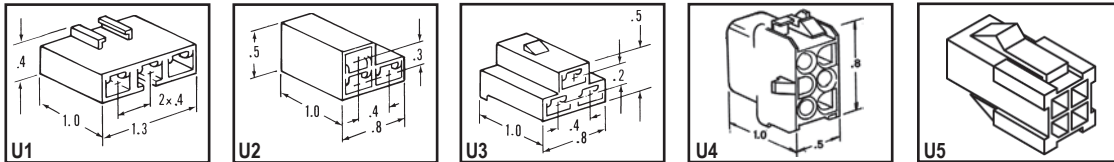

UNMATED (U) CONNECTORS

Description	Connector Part No.	Connector Item	Uses Terminal (See Below)
3 Wire	25 155 41-S	U1	Item 5, 6
3 Wire	237429-S	U2	Item 5, 6
3 Wire	52 155 06-S	U3	Item 5, 6
6 Wire	12 155 09-S	U4	—
Cap, Protective	24 139 06-S	U5	—

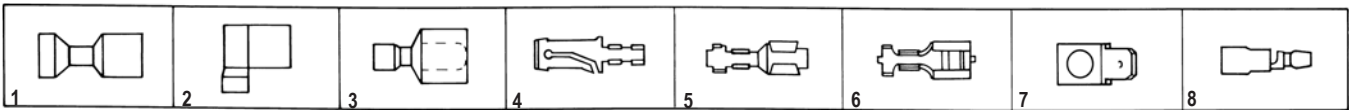

TERMINALS

Size	Part No.	Type	Code	Item	Type	Code
3/16" Flat	25 452 11-S	F.I.F.	S	1	F.I.F. = Fully Insulated Female	S = Straight push on tab
3/16" Flat	25 452 12-S	F.I.F.	F	2	F.I.M. = Fully Insulated Male	F = Flag push on tab
1/4" Flat	25 452 07-S	F.I.F.	S	1	L.F. = Locking Female	U = Uninsulated
1/4" Flat	15 452 01-S	F.I.M.	S	3	L.M. = Locking Male	
1/4" Flat	52 452 01-S	L.M.	S, U	4	M = Male	
1/4" Flat	25 452 01-S	L.F.	S, U	5		
1/4" Flat	25 452 06-S	L.F.	S, U	6		
1/4" Flat	12 452 02-S	M	45°, U	7		
1/8" Round	25 452 17-S	F.I.M.	S	8		

Guards, Screens, and Blower Housings

METAL CHOPPER GRASS SCREEN KITS

Kit No.

12 755 78-S

Replaces plastic screen on recoil start engines. Includes outer-edge guard and blower housing.

Models

CV11-16/460-493



Kit No.

24 755 79-S

Replaces plastic screen, or can replace "crowned" metal screen on engines below Serial No. 2528418567. A new blower housing is required if replacing a plastic screen.*

Note: When installing metal screen on an "open" application, guard kit 24 755 94-S is required.

*Due to blower housing variations, consult Kohler factory. Based on the spec number of your engine, the corresponding blower housing can be determined.

Models

CH/CV17-26/730-745

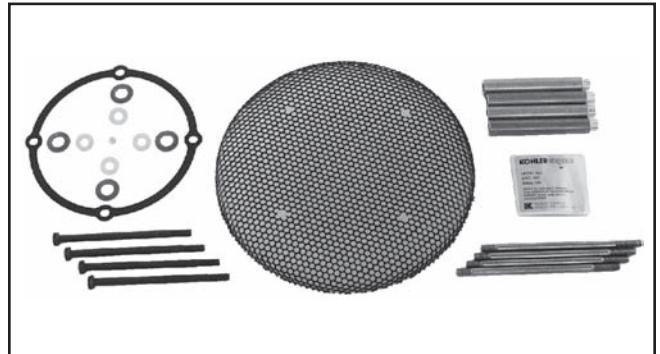

MANIFOLD COVER KITS

Kit No.

24 096 110-S

24 096 111-S

Covers hide exposed portion of intake manifold.

Model

CH750

CH750 (w/front mounted controls)

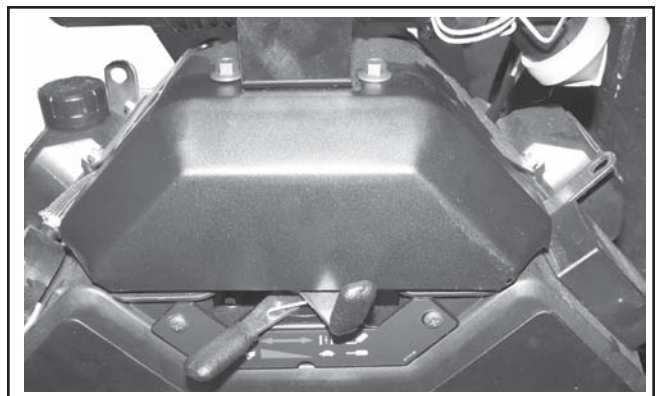
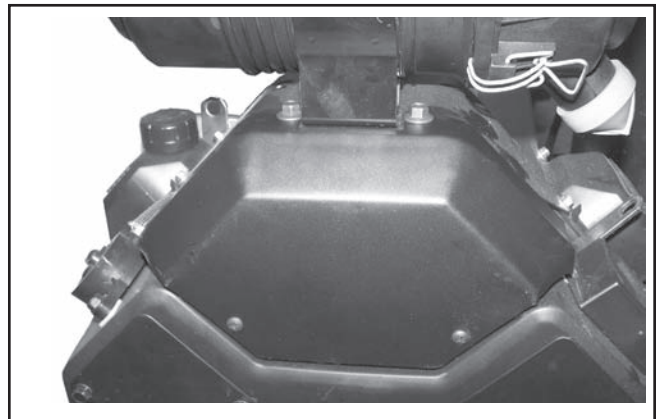

Guards, Screens, and Blower Housings

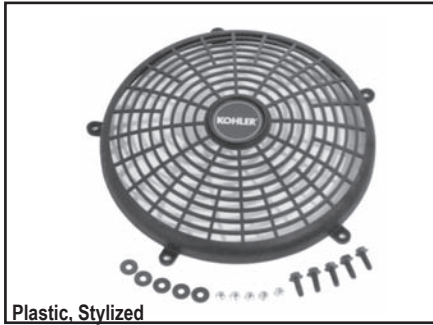

Plastic, Stylized

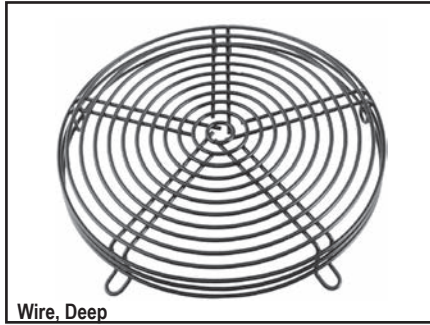

Wire, Deep

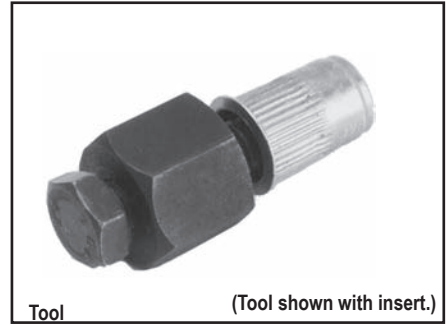

Tool

(Tool shown with insert.)

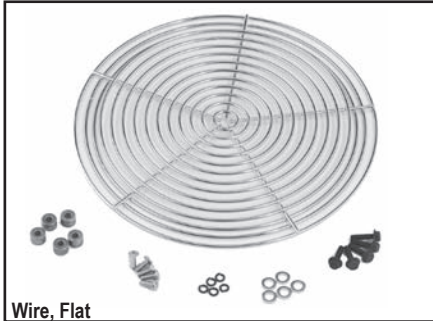

Wire, Flat



Metal, Recoil

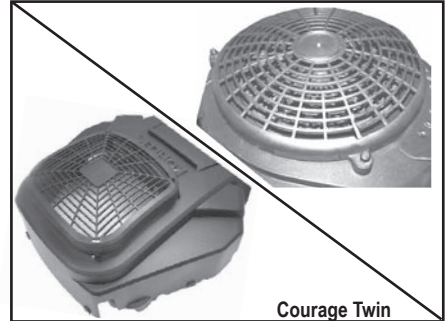

Courage Twin

FIXED GUARDS (NOT USABLE WITH RECOIL STARTER)

Model	Plastic, Stylized	Wire, Deep	Tool	Wire, Flat	Metal, Recoil
CS8.5-12.75	—	—	—	63 755 17-S	—
CH/CV11-16/460-493	12 755 65-S (Shown)	—	—	12 755 44-S (Shown)	12 755 48-S
SV470-620	20 755 11-S, 20 755 14**	—	—	—	—
CH/CV17-26/730-750	24 755 81-S*	24 755 94-S*	24 455 01-S	—	—
SV710-740	32 027 08-S	—	—	—	—

* Guard kits 24 755 81-S and 24 755 94-S include threaded inserts (24 332 01-S). Insert tool (24 455 01-S) is not included but needed to attach guard to existing blower housing. Tool is reusable. If engine has a metal grass screen, then only guard kit 24 755 94-S should be used. In addition, guard 24 755 94-S is required in open applications (mowers, etc.) to protect the metal screen from potential damage.

**Use 20 755 11-S if engine Serial No. is below 36145XXXXX, use 20 755 14-S if above.



1

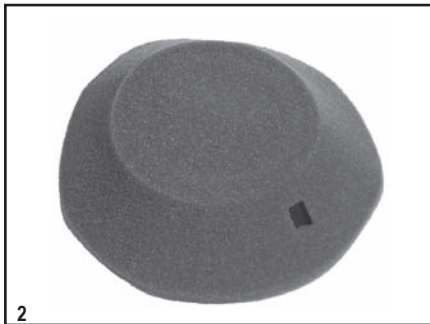

2

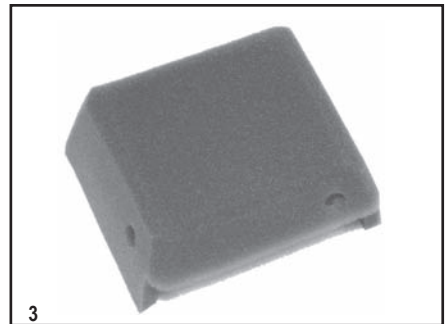

3

RECOIL STARTER FILTERS

Help prevent dust, dirt and debris from entering around recoil starter.

Part No.	Notes	Models	Item
63 755 18-S	Includes handle hole, Velcro, maintenance label and instructions.	CS4-6	1
12 050 02-S*	Includes handle hole. Conforms to shape of recoil housing when using fasteners*.	CV11-16/460-493	2
15 050 01-S**	Includes handle hole.	CH6	3

* For first-time usage, also order (10) 12 290 01-S Velstuds for holding the filter in place. Velstuds are reusable; they interlock with slots in starter housing.

** Also order 63 290 01-S Velcro strip (4.75" long). Cut into pieces for attachment of filter to starter housing.

Guards, Screens, and Blower Housings

BLOWER HOUSING CLEAN OUT PANELS

Kit No.	Description	Model
25 755 20-S	Matte Black Panel (2)	CH/CV17-26/730-750
25 755 21-S	Zinc Dichromate Panel (2) (Shown)	CH/CV17-26/730-750

Allows for cleaning debris from behind blower housing and also servicing of ignition modules. Kit includes instructions/template for cutting holes in blower housing, plus panels (one with pop-out plug and label for keyswitch), mounting clips and screws. (Blower housing not included.)



BLOWER HOUSING PLUGS

Part No.	Description	Model
24 096 17-S*	Triangular Plug (1) (Shown)	CH/CV17-26/730-750
24 096 85-S**	Triangular Plug With Lip (1)	CV17-26/730-750

*Seals the triangular hole in the blower housing underneath the air cleaner. Two required for CH twins, one for CV twins.

**Similar to 24 096 17-S, but has an extended rubber lip. Seals the triangular hole (under the air cleaner) through which the breather hose is routed. One required.



DUCTED AIR KIT

Kit No.	Description	Model
24 755 14-S	Ducted Air Kit	CH18-26/730-750



Front Drive Shafts

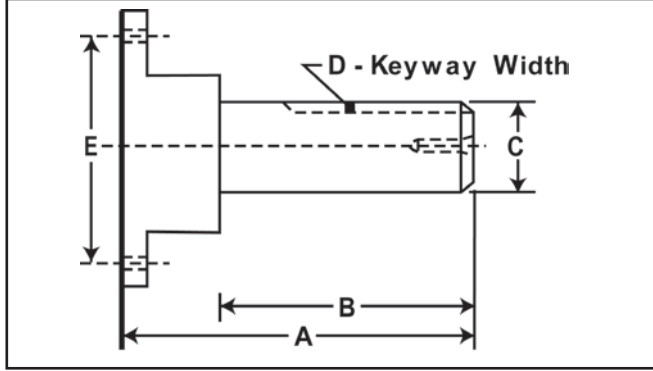

FRONT DRIVES (DIMENSIONS IN INCHES)

Part No.	A	B	C	D	E	Hardware Required	D & T	Model*
52 144 19-S	4.66	2.53	1.0	.25	3.0	See Below	3/8-16	CH11-15, LH640-775
235954-S	3.48	1.44	1.0	.25	3.0	See Below	3/8-16	CH11-15, LH640-775
237350-S	4.66	2.41	1.125	—	3.0	See Below	—	CH11-15, LH640-775
47 144 09-S	3.88	1.75	1.0	.25	3.0	See Below	7/16-20	CH11-15, LH640-775
52 144 07-S	3.80	1.80	1.0	.25WD	3.0	See Below	—	CH11-15, LH640-775
24 755 05-S	7.00	1.44	1.0	.25	3.0	See Below	3/8-16	CH18-26/730-750, LH640-775
24 755 06-S	7.00	1.76	1.0	.25	3.0	See Below	7/16-20	CH18-26/730-750, LH640-775
24 755 07-S	7.00	1.80	1.0	.25	3.0	See Below	—	CH18-26/730-750, LH640-775
24 755 08-S	7.00	2.53	1.0	.25	3.0	See Below	3/8-16	CH18-26/730-750, LH640-775
24 144 13-S	6.40	2.53	1.0	.25	3.0	See Below	3/8-16	CH18-26/730-750, LH640-775
24 144 16-S	5.35	2.53	1.0	.25	3.0	See Below	—	CH18-26/730-750, LH640-775
24 144 17-S	4.00	1.93	0.7**	.188WD	3.0	See Below	—	CH18-26/730-750, LH640-775
24 144 22-S	6.20	2.60	1.125	.25	3.0	See Below	—	CH18-26/730-750, LH640-775
24 144 23-S	4.84	2.82	1.0	.25	3.0	See Below	3/8-16	CH18-26/730-750, LH640-775
24 144 25-S	5.51	2.17	1.0	.25	3.0	See Below	—	CH18-26/730-750, LH640-775
24 144 26-S	3.94	1.06	0.625	.187	3.0	See Below	—	CH18-26/730-750, LH640-775
24 144 32-S	8.23	3.79	1.0	.25	3.0	See Below	M12 x 1.75	CH18-26/730-750, LH640-775
24 144 47-S	4.50	1.50	1.125	.25	3.0	See Below	7/16-20	CH18-26/730-750, LH640-775
24 144 51-S	5.98	2.36	1.0	.25	3.0	See Below	7/16-20	CH18-26/730-750, LH640-775
24 144 53-S	4.00	1.36	1.0	.25	3.0	See Below	3/8-16	CH18-26/730-750, LH640-775
28 144 05-S	5.28	3.07	1.125	.25	3.0	See Below	—	CH18-26/730-750, LH640-775
66 144 04-S	3.87	2.37	1.125	.25	3.0	See Below	—	CH18-26/730-750, LH640-775
62 144 07-S	4.54	2.30	1.125	.25	3.0	See Below	7/16-20	CH940-1000
62 144 09-S	5.33	2.00	1.125	.25	3.0	See Below	7/16-20	CH940-1000
24 144 55-S	4.50	1.50	1.0	.25	3.0	See Below	3/8-16	CH18-26/730-750

* Consult factory on: **CH11-15** since flywheel holes may vary and spec may not accept front drive: **LH640-775** to verify front loading.

**Threaded end (3/4"-16 UNF-2A).

WD = Woodruff Key

Required Hardware:

CH11-15: (2) X-22-2-S Washer, (2) M-1053030-S Screw.

CH18-26/730-750: (4) M-839025-S Screw (Included in -755 kits).

LH640-775: (4) M-839025-S Screw.

CH940-1000: (4) M-839035-S Screw.

SOME FRONT DRIVES REQUIRE:

LH640-775: Also order 66 096 18-S Flywheel Cover w/ hole for front drive or instruction sheet TT-5081 for a template to cut the hole in your existing flywheel cover.

All other models: Also order Grass Screen w/hole for front drive per table below. If changing from plastic screen to metal screen, also order blower housing. Contact customer service at factory for correct blower housing.

Grass Screen

Part No.	Type	Hole Dia. (In.)	Hardware Required To Attach New Screen	Model
12 162 03-S	Plastic	2.56	None	CH11-15
24 162 16-S	Plastic	1.42	(4) M-639016-S Screw, (4) 12 112 01-S Spacer	CH18-22
24 162 18-S	Plastic, Hi-Eff.	1.77	None	CH18-26/730-750
24 162 22-S	Metal*, Flat	1.57	None*	CH18-26/730-750
24 162 23-S	Metal*, Flat	2.95	None*	CH18-26/730-750
24 162 24-S	Metal*, Flat	2.46	None*	CH18-26/730-750
62 162 09-S	Metal	1.81	None	CH940-1000

*Flat design. If replacing older "crowned" version, also order 54 755 10-S Hardware Kit.

FUEL FILTERS

Part No.	Inlet Hose		Shell Length	Model
	I.D.	Micron		
14 050 04-S	3/16, 1/4"	60	.67"	Standard: XT-7
25 050 21-S1	1/4"	75	2.13"	Standard: CH/CV11-15/493PRO*
24 050 13-S	9/32"	9-12	2.35"	Standard: CH/CV17-25/730-740,750 LV625-680, LH640-755, SV470-620, SV710-840
24 050 03-S	5/16"	8-10	5.51"	Standard: All EFI (metal, high pressure, between fuel pump and engine)
24 050 12-S	3/8"	80	5.51"	Standard: All EFI (plastic, low pressure, between fuel tank and fuel pump)
25 050 07-S	3/16, 1/4"	75	1.0"	Standard: CH/CV11-16/460-492 non-PRO (electric start)
25 050 22-S	1/4"	51	2.13"	Standard: CH/CV11-15/493 PRO (recoil start)

*Standard on PRO specs with gravity-feed carb. For PRO specs with fuel pump, filter 25 050 22-S is standard.

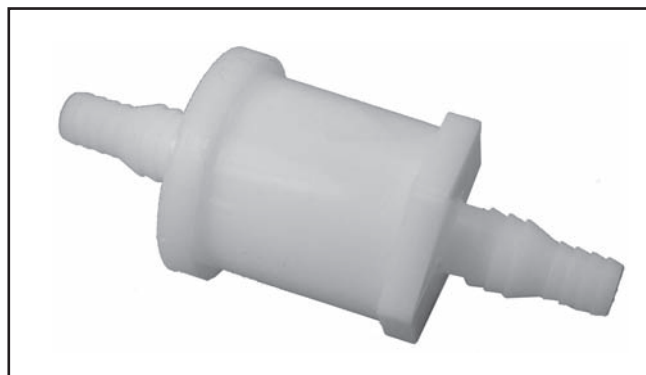

LOW PERMEATION FUEL LINE

Part No.	I.D.	Length	Model
25 111 34-S	1/4"	24"	All except EFI
25 111 39-S	1/4"	25' (bulk roll)	All except EFI
25 111 37-S	5/16"	5'	EFI Only



ALCOHOL CONTENT TESTER

Part No. - Tests for E10/E20/E85
25 455 11-S

HIGH-ALTITUDE KITS

Kit No.	Altitude*	Used on Carb	Models/ Series	A/C Style
14 755 03-S	5-10,000	14 053 01	XT-7	Standard
14 755 04-S	5-10,000	14 053 02	XT-7	Standard
12 755 92-S	5-10,000'	12 053 77/78/ 80/82/93/94/ 95/139/140, 42 053 03	CH/CV11-15	Standard
12 755 108-S	5-10,000'	12 053 117/118/ 136/145/148/149	CV490-493	Standard
20 755 06-S	5-10,000'	20 053 01/02/04/05	SV530-620	Standard
20 755 07-S	10,000'+	07/14/15/16/17/ 19/20/21/22	SV530-620	Standard
20 755 08-S	5-10,000'	20 053 03/06/18/23	SV470,480	Standard
20 755 09-S	10,000'+		SV470,480	Standard
24 755 131-S	5-10,000'	24 053 75	CH20 (624cc)	Flat
	5-10,000'	24 053 86	CH22/23 (674cc)	Flat
24 755 125-S	5-10,000'	24 053 31/ 32/33/43	CH18/22 (624cc)	Flat
	5-10,000'	24 053 58/59	CH22/23 (674cc)	Flat
24 755 126-S	5-10,000'	24 053 47	CH25	Flat
24 755 130-S	5-10,000'	24 053 34	CH25	Flat
24 755 138-S	5-10,000'	24 053 93	CH730-740	Flat
24 755 137-S	10,000'+	24 053 93	CH730-740	Flat

*5-10,000' = 1500-3000 m.

Kit No.	Models/ Altitude*	A/C Series	Style
63 755 20-S	4-8,000'	CS4	Standard
63 755 22-S	8,000'+	CS4	Standard
	4-8,000'	CS4	Heavy-Duty
63 755 25-S	8,000'	CS4	Heavy-Duty
63 755 21-S	4-8,000'	CS6	Standard
63 755 23-S	4-8,000'	CS6	Heavy-Duty
63 755 24-S	8,000'+	CS6	Standard
	4-8,000'	CS6	Rectangular
63 755 26-S	8,000'+	CS6	Heavy-Duty
63 755 38-S	8,000'+	CS6	MZ
Rectangular			
63 755 27-S	4-8,000'	CS8.5 (250cc)	Standard
	8,000'+	CS8.5 (250cc)	Heavy-Duty
63 755 29-S	8,000'+	CS8.5 (250cc)	Standard
63 755 28-S	4-8,000'	CS8.5 (250cc)	Heavy-Duty
63 755 30-S	4-8,000'	CS10/9316	Standard
	8,000'+	CS10/9315	Standard
	4-8,000'	CS12/9415,9416	Heavy-Duty
63 755 33-S	4-8,000'	CS10/9315,9416	Heavy-Duty
63 755 35-S	8,000'+	CS10/9316	Standard
63 755 36-S	8,000'+	CS10/9315	Heavy-Duty
	8,000'+	CS10/9316	Heavy-Duty
	8,000'+	CS12/9415	Rectangular
63 755 31-S	4-8,000'	CS10/9315	Standard
	4-8,000'	CS12/9415	Rectangular
63 755 32-S	4-8,000'	CS12/9415	Standard
	4-8,000'	CS12/9416	Standard
63 755 34-S	8,000'+	CS12/9415	Standard
	8,000'+	CS12/9416	Standard
63 755 37-S	8,000'+	CS12/9415	Heavy-Duty
	8,000'+	CS12/9416	Heavy-Duty

*4-8,000' = 1200-2400 m.

Fuel



FUEL TANK KITS

Kit No.	Tank Mounting	Tank Material	Tank Capacity (Gal.)	Includes Cap	Model	Item
12 760 01-S	Engine	Plastic	1.25	25 173 08-S	CH11-15	1
25 755 35-S*	Remote	Plastic	6.0	25 173 22-S	All	2

*Overall size is 19.6"x 14.2" x 9.3".

FUEL TANK CAPS

Item	Part No.	Gauge in Cap	Fits
1	25 173 04-S	Yes	Voided 52 755 45 remote metal tank
1	25 173 21-S	Yes	Voided 52 755 79 remote plastic tank
2	25 173 22-S	No	25 755 35 remote plastic tank
3	25 173 20-S	No	CH11-15
4	14 227 06-S	No	XT-7
5	14 227 04-S	No	XT-7

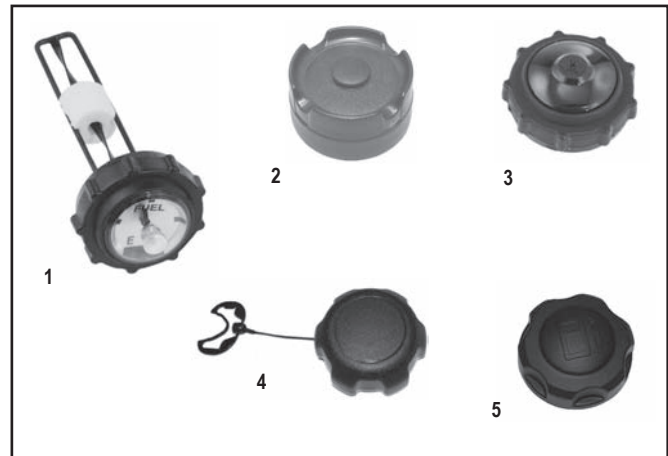

ELECTRIC FUEL PUMP

Kit No.	Model	P.S.I. at 0 Delivery	Self-Prime Lift	Total Column
25 559 01-S	All except CH6, CS, & EFI	0.5-2.0	12"	6'

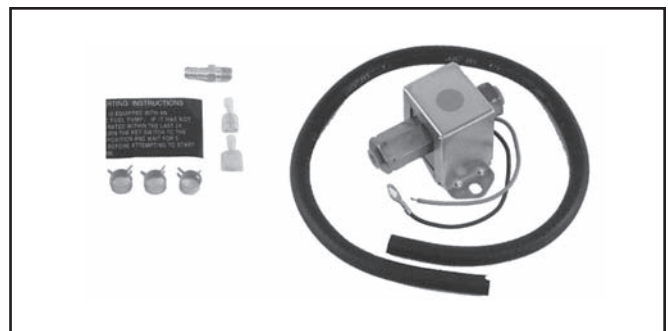

ELECTRIC FUEL RELAY

Part No.	Models
20 404 01-S	All

EFI ELECTRIC FUEL PUMP - HIGH PRESSURE

Part No	Model	P.S.I	G.P.H.	AMPS Max
24 393 52-S	All EFI	50	15.0	5.0



PULSE FUEL PUMP

Part No.	Model	Item
24 393 16-S	CH/CV17-25/730-740, LV625-675	1

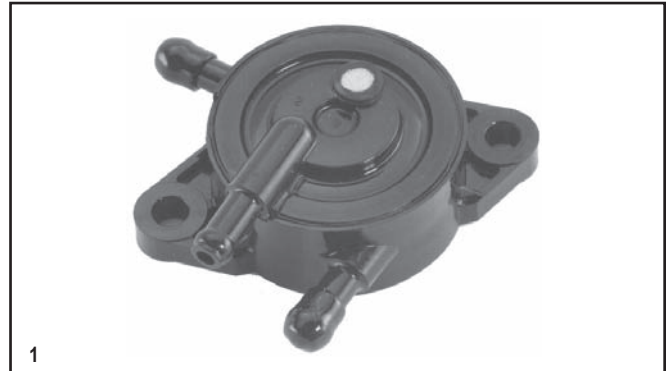

MECHANICAL FUEL PUMPS

Part No. (Non-Metallic)	Model	Item
12 559 02-S	CH/CV11-16/460-493	1
24 559 10-S*	CH18-25/730-740	2
62 559 01-S***	CH940-1000	3

* Integral valve cover. For #2 cylinder side (oil filter side) only. For engines below Serial No. 2520800017, also order Valve Train Kit 24 755 66-S to convert to compatible rocker arms.

** Fittings include o-ring 25 153 03-S.

*** Integral valve cover. For #2 cylinder side (oil filter side) only.

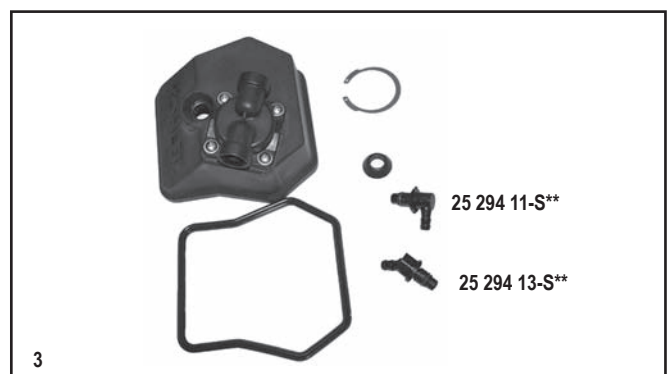
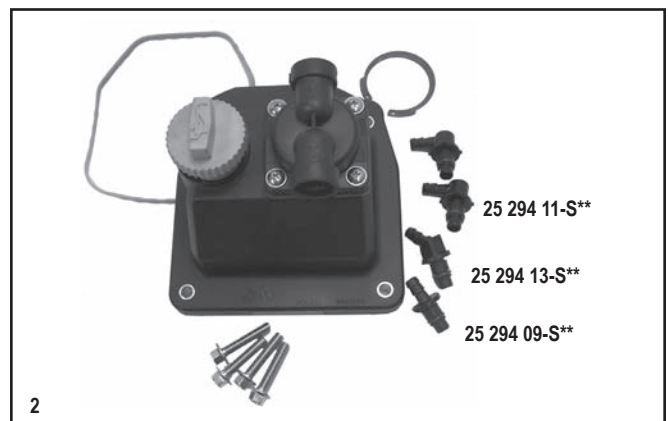

Controls

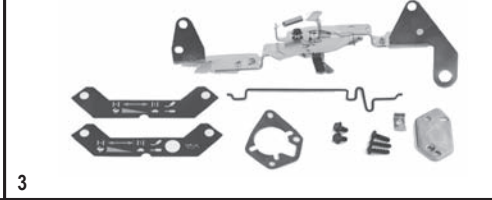
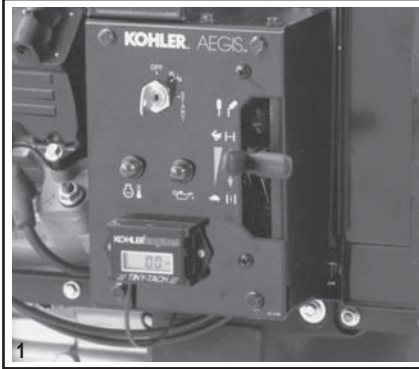

ENGINE-MOUNTED CONTROL PANELS

Kit No.	Mounting Location	Major Components	Models	Item
66 755 09-S*	Filter Side (only)	Panel, keyswitch, choke, throttle, low oil light, harness	LH640-755	1
24 225 02-S**	Front Side	Bracket, levers, cable assembly	CH18-26/730-745	2
24 755 106-S**	Front Side	Panel, choke, throttle (includes item 2)	CH18-26/730-745	3
24 711 01-S***	Filter Side	Panel, keyswitch, choke, throttle, low oil light, harness	CH18-26/730-740	4
62 376 02-S	Front Side	Panel, keyswitch, indicator light, choke/throttle brackets	CH940-1000	-

* Shown with optional additional items: Coolant Temp Gauge and Coolant Temp Light (only one may be used), and Tiny Tach/Hourmeter.

** For installation of lever-type throttle/choke which became standard since Serial No. 3009400011. Also order Air Cleaner Cover 24 096 26-S if adding controls to non-panel engine spec.

*** Will not work with radiator-style oil cooler or on same side as side-mounted muffler.



COOLANT ITEMS

Kit No.	Description	Models	Item
66 755 06-S*	Gauge, Coolant Temperature	LV625-680	1
66 755 11-S**	Gauge, Coolant Temperature	LH640-775	1
66 755 12-S***	Light, Coolant Temperature	LH640-775	2

* Includes gauge, temp. sensor, wiring (up to 6' from engine).

** Includes gauge & holder for mounting atop control panel shown above, temp. sensor, harness.

*** Includes light/wiring, temp. switch.

Note: Coolant gauges show green band for safe temp., red band for hot.



LUBRICATION ITEMS

Kit No.	Description	Models	Item
66 755 13-S*	Gauge, Oil Pressure (0-100 psi)	LH640-775	1
25 352 10-S**	Light, Oil Warning	CH18-26/730-745	2
25 352 12-S**	Light, Oil Warning	LH640-775	2
12 704 02-S***	Light, Oil Warning	CH/CV11-16/460-493	2

* Includes gauge & holder for mounting atop control panel shown above, switch, wiring.

** Includes light, 6.5" & 9" leads, fits in control panels shown above.

*** Includes light, 6" lead, switch, wiring.



THERMOSTAT

No gasket or o-ring included.

Kit No.	Description	Models
66 453 02-S	190°F Thermostat	LV625-680, LH640-775
66 453 03-S	205°F Thermostat	LV625-680, LH640-775

HORN ALERT KIT

Includes alarm, coolant temp. switch, harness. Already std. on LV.

Kit No.	Description	Models
66 755 05-S	Horn Alert Kit*	LV625-680, LH640-775
66 556 01-S	Horn (only)*	All w/electric start

*Provides audible alarm in conjunction with or in place of light or gauge.

CAUTION (ALL WARNING DEVICES ON THIS PAGE):

1. If overheating occurs, remove load, run engine at high speed to create air flow for cooling engine.
2. If low oil level/pressure occurs, stop engine immediately.

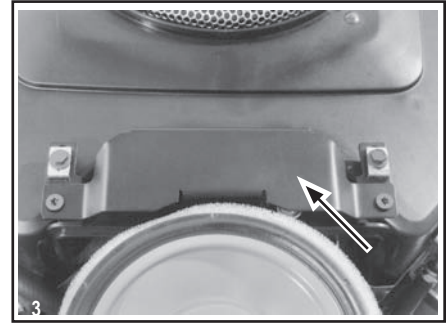
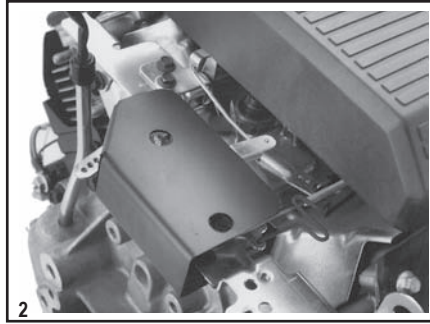
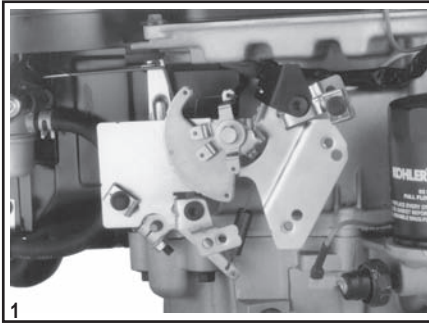

TAMPER-RESISTANT CONTROL KITS

Prevents tampering with high-speed adjustment (as proposed by European regulations).

Kit No.	For Model	When Models Are Equipped With	Note	Item
None	CH/CV11-16/460-493	Standard Controls	A	—
12 755 71-S	CV11-16/460-493	Dual Controls	B	1
24 755 93-S	CH/CV18-26/730-745, LH640-775	Standard Controls	C	2
24 755 97-S	CV18-26/730-745	Top Controls	C	3

A — Engines with Serial No. 2527814194 and higher are tamper-resistant upon leaving the factory. To retrofit older engines, order (2) M-664020-S TORX screws to replace the hex head screws on the control bracket.

B — Includes cover and (2) TORX screws for attachment to control bracket.

C — Includes cover and (2) TORX screws for attachment to control bracket. Instructions are included to add holes to the bracket if there are none.

DEBRIS COVER

Part No.	Description	Model
24 063 32-S	Debris Cover	CH18-26/730-745, LH640-775

Sheet metal cover protects against debris buildup over controls. Uses existing screws. Compatible with various dipsticks and mufflers, including "QS" ducting.

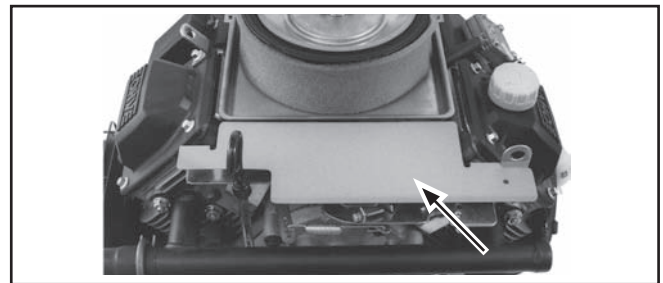

KEY SWITCH & KEYS

Part No.	Description	Model	Item
25 099 04-S	Switch (5 pin) & Key Magneto		1
25 099 29-S	Switch (5 pin) & Key CH940-1000		1
52 099 02-S	Switch (3 pin) & Key EFI		1
25 099 30-S	Switch (5 pin) & Key	CH640-750, CV17-26, CV624-750	2
48 340 01-S1	Keys (2) Only All		3



Controls

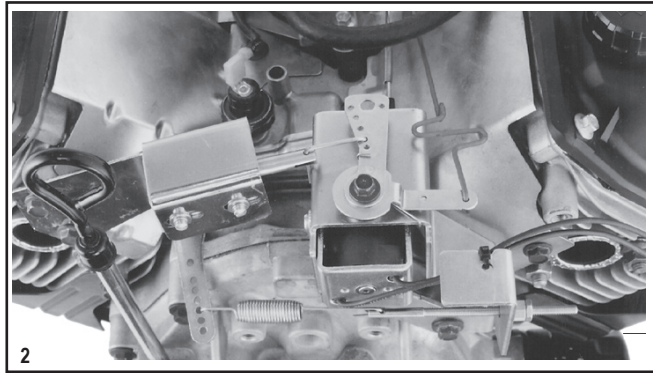
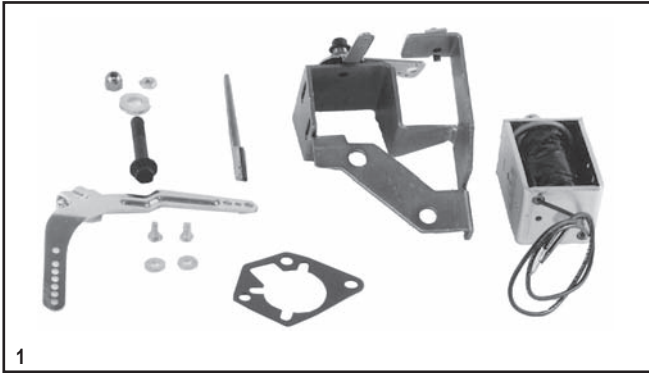

SOLENOID-OPERATED CONTROLS (12 DC VOLTS)

Kit No.	Description	For Engines With	Models	Item
24 755 100-S	Idle Kit*	Constant Speed	CH18-25/730-740, LH640-755***	1
24 755 101-S	Throttle/Choke Kit**	Constant Speed	CH18-25/730-740, LH640-755***	2

* When voltage is applied to solenoid, engine speed is "low idle." When voltage is removed, engine speed is "high idle."
 ** Allows start-up to constant high speed from remote equipment (lift platform, etc.).
 *** Mounting bracket will interfere with manifolds on CH18-25/730-740 side mufflers. Also 24 164 04-S crossover manifold.

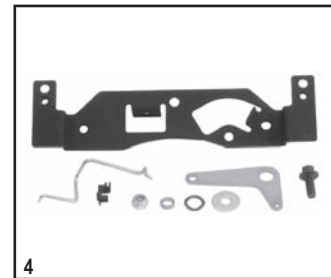
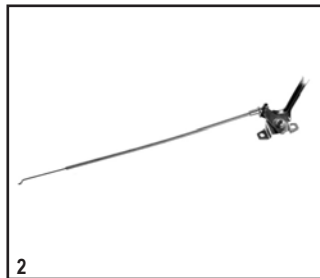

THROTTLE CONTROL

Part No.	Description/Mount Type	Cable Length	Models	Item
63 089 23-S	Throttle Return Spring*	—	CS4-12	1
225011-2-S	Remote	41-51"	All	2
225011-6-S	Remote	60-72"	All	2
225011-7-S	Remote	12-40"	All	2
230326-1-S	Remote	15"	All	2
235160-S	Remote	5.625"	All	3

*For recreational vehicle applications. Returns engine speed to idle when foot pedal is released.

CHOKE CONTROL

Part No.	Description/Mount Type	Models	Item
24 755 95-S	Choke Control Kit (Adds choke control lever to top controls.)	CV17-25/730-740 Com. Mowers	4

Electrical Accessories

HIGH TEMPERATURE CUTOUT SWITCHES

Kit No.	Cutout Range	Reset	Model
12 703 01-S	346-360°F	310°F	CH/CV11-16/460-493 SV470-610

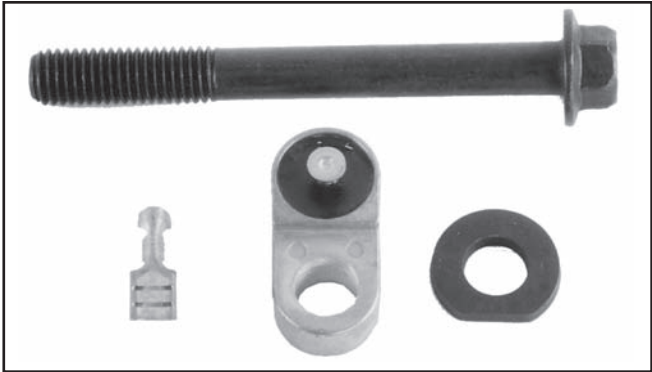

Kit No.	Cutout Range	Reset	Model
24 703 01-S	440-490°F	415°F	CH/CV17-26/ 730-745 SV710-740

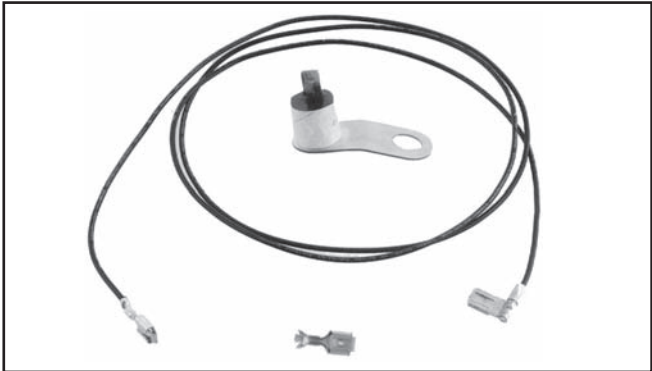

MALFUNCTION INDICATOR LAMP (MIL)

Part No.	Models With
25 352 19-S	Electronic Fuel Injection (EFI)



Air Intake

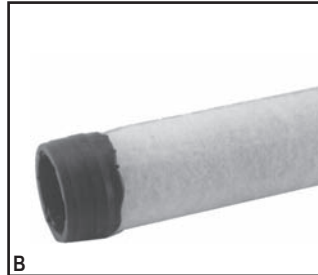
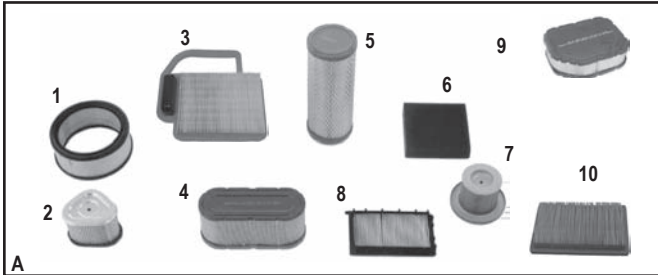

ELEMENTS & PRECLEANERS

Note: Elements and precleaners may appear differently for various models.

Style	Element (Photo A)	U.L. Element Equivalent	Inner Element (Photo B)	Precleaner (Photo C)	Model
1	45 083 02-S	52 083 04-S	—	45 083 01-S	CV17-26/730-745 (Commercial mowing)
1	47 083 01-S	47 083 04-S	—	52 083 01-S	CH11-15
4	63 083 03-S	—	—	63 083 04-S	CS4-6 (Standard, dual element)
4	63 083 11-S	—	—	63 083 12-S	CS8.5/250cc (Standard, dual element)
4	63 083 01-S	—	—	63 083 02-S	CS8.5/300cc, 10-12 (Standard, dual element)
6	63 083 06-S	—	—	—	CS4-6 (Foam, single element)
6	63 083 05-S	—	—	—	CS8.5/300cc, 10-12 (Foam, single element)
7	63 083 07-S	—	—	63 083 08-S	CS4-6 (Heavy-duty cyclonic)
7	63 083 10-S	—	—	63 083 09-S	CS8.5/250-300cc, 10-12 (Heavy-duty cyclonic)
8	63 083 13-S	—	—	63 083 14-S	CS8.5/250cc (Low profile, dual element)
4	63 083 15-S	—	—	63 083 16-S	CS10(931600),CS12 (941600)
3	20 083 02-S	—	—	20 083 03-S	SV470-620
2	12 083 05-S*	12 083 09-S*	—	12 083 08-S	CV11-16/460-493 (Standard, 2.8" High)
2	12 083 10-S*	12 083 13-S*	—	12 083 12-S	CV11-16/460-493 (Tall, 3.4" High)
1	47 083 03-S	24 083 08-S	—	24 083 02-S	CH/CV17-23 (Flat)
1	24 083 03-S	24 083 09-S	—	24 083 05-S	CH/CV25-26/730-745 (Flat)
5	24 083 07-S	—	—	—	CH/CV17-22 Metal H.D. A/C
5	25 083 01-S	—	25 083 04-S	—	CH/CV17-26/730-745/LH640-775 Plastic H.D. A/C
9	32 083 03-S	—	—	32 083 05-S	SV710-740 (Standard, 1.73" High)
9	32 083 06-S	—	—	32 083 08-S	SV810-840 (Large, 3" High)
4	66 083 01-S	—	—	66 083 03-S	LV625-680
10	14 083 01-S	—	—	14 083 02-S	XT-7

Notes: *Includes element and rubber seal.

ALSO SEE PAGE 16 FOR RECOIL STARTER FILTERS.

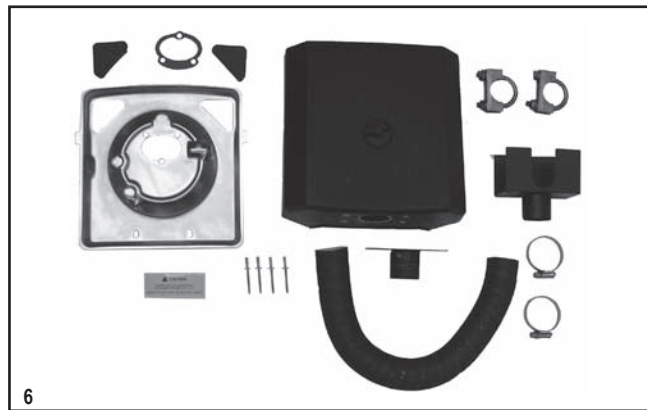
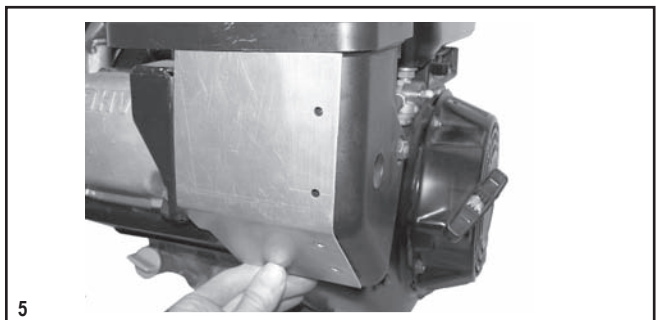
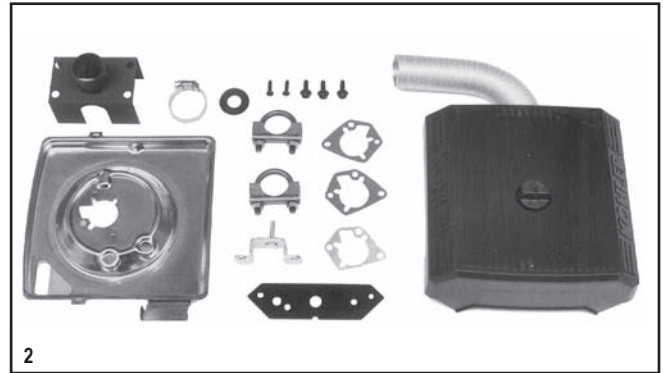
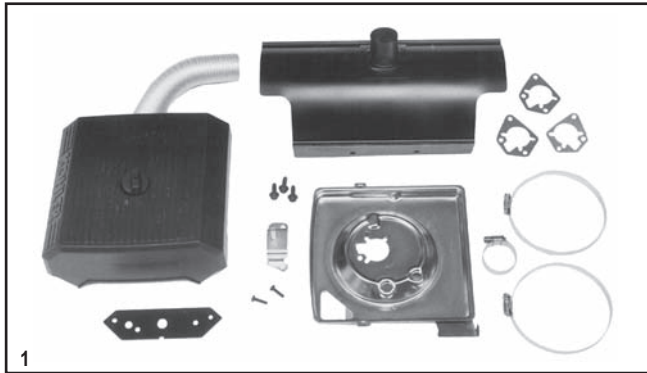

ANTI-ICING COMPONENTS

If the included instructions are followed, these kits/parts may be used without jeopardizing CARB/EPA certification on the engine.

Kit No.	Model	As Low As	Notes	Heat From	Item
24 755 64-S	CH18-22	20°F	For PTO mufflers	Muffler	1 (shown)
24 755 65-S	CH25-26/730-745	20°F	For PTO mufflers	Muffler	1
24 755 68-S*	CH18-22	20°F	For side mufflers	Manifold	2 (shown)
24 755 69-S*	CH25-26/730-745	20°F	For side mufflers	Manifold	2
24 755 82-S	CH18-26/730-745	-20°F	Includes starter side muffler***	Muffler	3
24 755 83-S*	CH18-22	-20°F	Includes filter side muffler***	Muffler	3 (shown)
54 755 06-S**	CH/CV17-26/730-745	—	Not for comm'l. mowers	—	4
63 755 39-S	CS8.5-12	20°F	—	—	5
12 168 02-S	CH18-26/730-745	—	Foam insulation only	—	—
24 168 01-S	LH640-775	—	Breather hose insulation	—	—
24 755 165-S	CH750 w/Flat Air Cleaners	—	For side mufflers	Manifold	6
12 326 24-S****	CH11-15	—	Insulated breather hose	—	7

* Not for use on filter side of engine if equipped with oil cooler.

** Increases carb temperature approx. 13°F. Covers triangular holes (2) in blower housing. Remove above 45°F.

*** Tubes travel through mufflers to bring warm air to air cleaner.

**** Replaces existing breather hose to prevent icing, or order insulation only and install over existing hose.

Air Intake



FUEL RECOVERY/SPITBACK CONTROL SYSTEM

Kit No.	Description	Model
12 755 84-S	Fuel Recovery/Spitback Control Kit	CH11-15

Prevents fuel spitback and oil mist from affecting air cleaner element, or allowing residue to drip off air cleaner base. Engines built after Serial No. 2721720234 include this system.

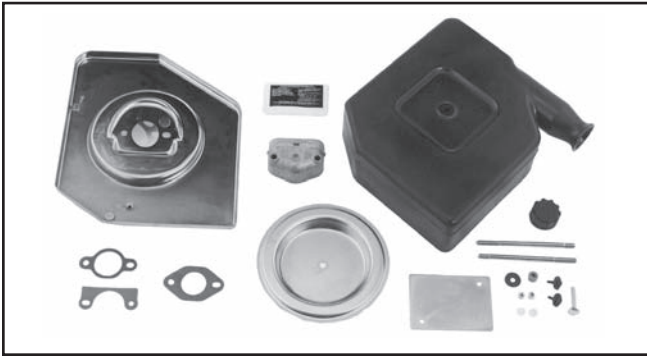

PLENUM DOME COVER KIT

Kit No.	Snorkel O.D.	Hose Clamp Surface	Model
12 743 10-S	1.75"	0.625"	CH11-15

Note: May attach to customer-supplied remote-mount air cleaner or precleaner and hose. Requires Kohler review for CARB/EPA approval or if TT sheet guidelines for connections cannot be met.

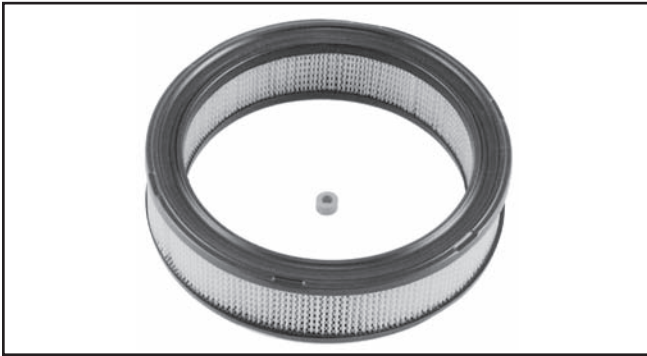

SEAL RETROFIT KIT

Kit No.	Description	Model
12 743 09-S	Seal Retrofit Kit	CH11-15

For engines before Serial No. 2519500004. Seal replaces loose washer and grommet in cover plate. Kit includes seal and element.



Part No.	Description	Model
12 096 41-S	Air Cleaner Cover (w/multilingual maintenance instructions)	CH11-15

Standard air cleaner cover, including multilingual maintenance instructions embossed underneath. Now available individually for engines built earlier.

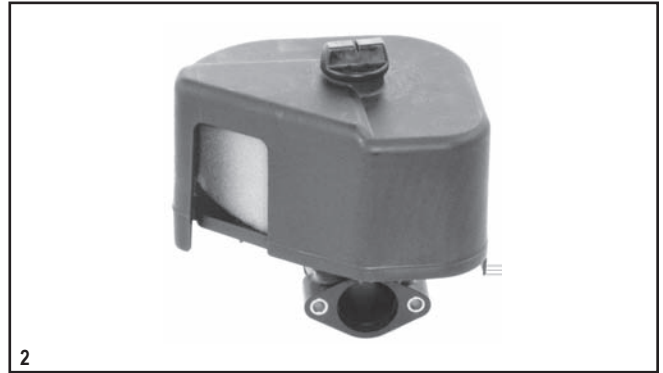
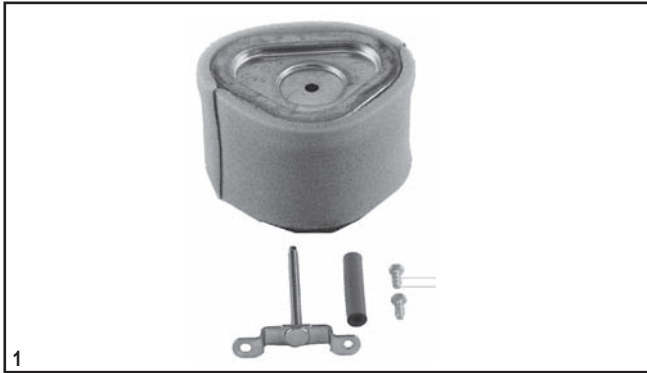

AIR CLEANER RETROFIT KITS

Kit No.	Description
12 743 03-S	Converts standard filter to a larger filter
12 743 04-S	Cover has opening to line up with opening in blower housing
A — Pro Series "T/ST" after Serial No. 2404917244, Pro Series "S" after Serial No. 2424505854.	
B — Basic "S", lawn tractors.	
*Large capacity filter is 20% greater than standard filter.	

Includes Filter	For Spec.	Item
Large*	A	1
Large*	B	2

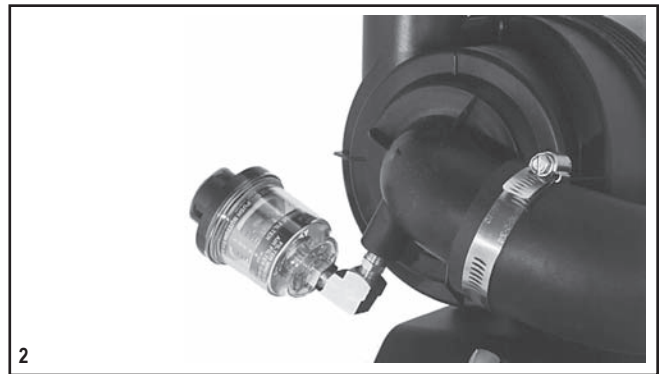

FILTER MINDER

Vacuum-type gauge detects air inlet restrictions, signaling when to service air filter (when yellow indicator reaches red line).

Kit No.	Mounting	Air Drawn From	Model	Item
25 755 18-S	Remote	Air cleaner base plate or heavy-duty air cleaner elbow	CH/CV11-16/460-493, CH/CV17-26/730-745	1
25 755 24-S	Direct*	Heavy-duty air cleaner elbow	CH18-26/730-750, CV493	2
62 330 02-S	Direct	Heavy-duty air cleaner	CH/CV940-1000	-

* Includes brass fittings, instructions.

Air Intake

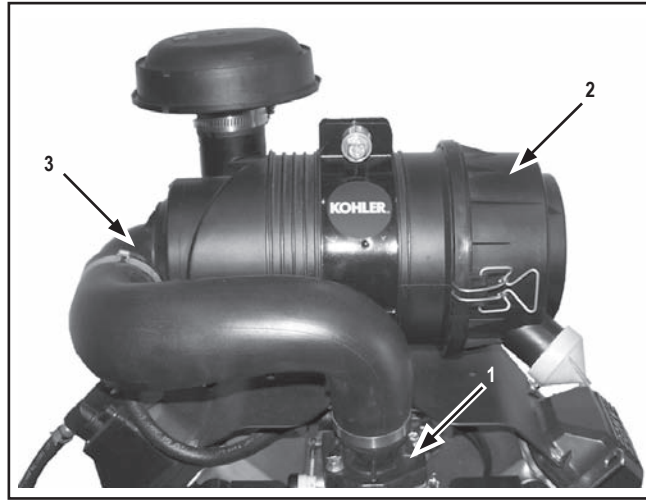

HEAVY-DUTY AIR CLEANER KITS (Convert from Flat Air Cleaner)

Complete, engine-mounted system (items 1 and 2 used together) is CARB/EPA certified. Any remote-mounting configuration (item 1 plus remote-mounted air cleaner), must be Kohler approved for CARB/EPA. Filtering area is 1,398 sq. in. **Not usable on engines with plastic intake manifold.**

Kit No.	Description	Includes	Use With	Model	Item
24 743 20-S	Elbow/Adapter Kit*	A	AA	CH18-22 (624cc)/730-740	1
24 743 25-S	Elbow/Adapter Kit	A	AA	CH22/23 (674cc)	1
24 743 21-S	Elbow/Adapter Kit	A	AA	CH25	1
24 743 34-S	Elbow/Adapter Kit	A	AA CH26/745	EFI	1
24 743 22-S	Air Cleaner Kit (90° canister elbow)**	B	BB	All	2
24 743 23-S	Air Cleaner Kit (Straight canister elbow)***	C	BB	All	2
25 755 24-S	Filter Minder Kit (Elbow mounted)****	D	AA	All	3
25 755 18-S	Filter Minder Kit (Remote mounted)*****	E	AA	All	—

* For CH730/740, carburetor replacement is necessary. Order assembly 24 853 93-S.

** Typically used for engine-mounted configuration (as shown). If remote-mounted, customer supplies hose (must be Kohler approved for CARB/EPA).

*** Used with customer-supplied hose for remote-mount location. (Must be Kohler approved for CARB/EPA).

**** Attaches to air canister elbow (per item 3). (See earlier page for description.)

***** Attaches to any remote location (front of engine, application, etc.). (See earlier page for description.)

Kits include instructions plus:

- A - Elbow/adapter, mounting bracket, 2" I.D. hose, hardware, debris shields for either knob-type or lever-type controls (see below).
- B - Air cleaner canister, rain hood (25 324 02-S), main and inner filters, plug (25 139 20-S) to close Filter Minder opening if not used.
- C - Air cleaner canister, rain hood (25 324 02-S), main and inner filters, cap (25 173 19-S) to close Filter Minder opening if not used.
- D - Filter Minder, brass fittings.
- E - Filter Minder, brass fittings, 10' hose, mounting bracket.

Use with:

AA - Air Cleaner Kit 24 743 22-S . . . or customer-supplied air cleaner, which must be Kohler approved for CARB/EPA.

BB - Elbow/Adapter Kit 24 743 20-S, 25-S, 21-S or 34-S.

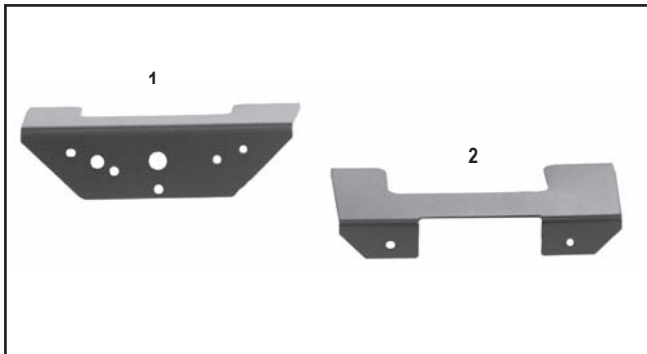

DEBRIS SHIELDS

Both shields are included in Heavy-Duty Air Cleaner Kits above (carb/elbow) to prevent debris from interfering with throttle/choke controls. (Only one shield needed depending upon engine spec.)

Part No.	Used With	Model	Item
24 314 25-S	Knob-type controls, no controls, remote air cleaner (shown above)	CH18-26/730-745	1
24 314 29-S	Lever-type controls*	CH18-26/730-745	2

*Lever-type controls have been standard on CH18-25 panel specs since Serial No. 3009400011.

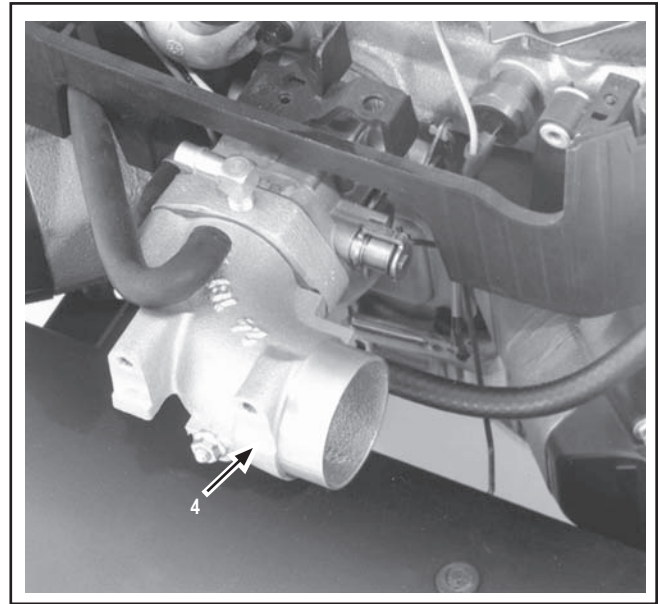
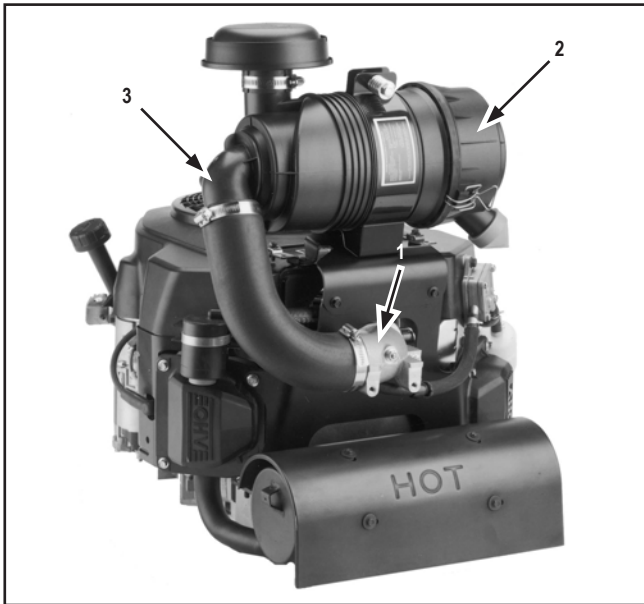

HEAVY-DUTY AIR CLEANER KITS (Convert from Flat or Commercial Mower Air Cleaner)

Complete, engine-mounted systems are CARB/EPA certified. Remote systems using either KOHLER or customer-supplied air cleaner and hose, must be Kohler approved for CARB/EPA. Filtering area is 1,398 sq. in. **Not usable on Command engines with plastic intake manifold.**

Kit No.	Description	Includes	Use With	Model	Item
24 743 36-S	Elbow/Adapter Kit	A	AA	Command CV18-22 (624cc)	1
24 743 37-S	Elbow/Adapter Kit	A	AA	Command CV22/23 (674cc)	1
24 743 38-S	Elbow/Adapter Kit	A	AA	Command CV25/730-740	1
24 743 39-S	Complete Kit	B	-	Command CV26/745 EFI	1,2
24 743 22-S	Air Cleaner Kit (90° canister elbow)*	C	BB	Command or Aegis*****	2
24 743 23-S	Air Cleaner Kit (straight canister elbow)**	D	BB	Command or Aegis*****	2
66 743 01-S	Elbow/Adapter Kit (remote only)	E	CC	Aegis LV625-675	4
25 755 24-S	Filter Minder Kit (Elbow-mounted***)	F	AA	All	3
25 755 18-S	Filter Minder Kit (Remote-mounted****)	G	AA	All	-

* Typically used for engine-mounted configuration (as shown). Not compatible with vertical positioned mufflers as shown in EXHAUST section.

** Used with customer-supplied hose for remote-mount location. (Must be Kohler-approved for CARB/EPA).

*** Attaches to outlet in canister. (See appearance and description of Filter Minder on earlier page.)

**** Attaches to any remote location. (See appearance and description of Filter Minder on earlier page.)

***** Usable on Aegis but **only** in remote-mount configuration, not engine-mounted.

Kits include instructions plus:

A - **Carburetor**, elbow/adapter, mounting brackets, 2" I.D. hose, hardware.

B - Elbow/adapter, mounting brackets, 2" I.D. hose, hardware, plus C.

C - Air cleaner canister(†), rain hood (25 324 02-S), main and inner filters, plug (25 139 20-S) to close Filter Minder opening if not used.

D - Air cleaner canister(‡), rain hood (25 324 02-S), main and inner filters, cap (25 173 19-S) to close Filter Minder opening if not used.

E - Elbow/adapter, air cleaner gaskets, misc. hardware. Customer supplies 2" I.D. remote hose to air cleaner. (Must be Kohler-approved for CARB/EPA.)

F - Filter Minder, brass fittings.

G - Filter Minder, brass fittings, 10' hose, mounting bracket.

(†) 90° air cleaner canister is comprised of: 25 081 01-S main body, 25 096 06-S end cap w/ejector valve & clips.

(‡) Straight air cleaner canister is comprised of: no - S part number for main body, 25 096 06-S end cap w/ejector valve & clips.

Use with:

AA - Air Cleaner Kit 24 743 22-S . . . or customer-supplied air cleaner and hose, which must be Kohler-approved for CARB/EPA.

BB - Elbow/Adapter Kit 24 743 36-S, 37-S and 38-S; or 66 743 01-S (remote-mount only).

CC - Air Cleaner Kit 24 743 22-S or 23-S may **only** be used in remote-mounted configuration, not engine-mounted. Customer supplies 2" I.D. hose. (Must be Kohler-approved for CARB/EPA.)

Air Intake

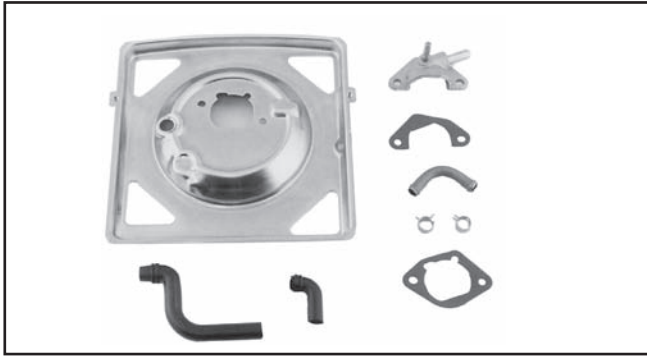

AIR CLEANER BASE/BREATHER KIT

Kit No.	Description	Model
24 755 86-S	Base/breather kit	CV17-25/730-740

Note: Breather system for models with accelerator pump carburetor.

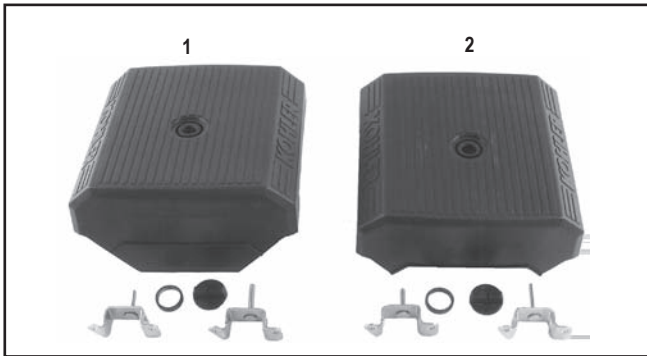

AIR CLEANER COVER KITS STANDARD

Kit No.	For Engine With	Model	Item
24 743 05-S	No control panel	CH/CV17-25/730-740*	1
24 743 06-S	Control panel	CH18-26/730-740	2

Note: Covers include embossed KOHLER name on outside, maintenance instructions on inside (English, Spanish, German, French).
*CV17-25/730-740 with standard air cleaner also requires 24 755 86-S kit (above).

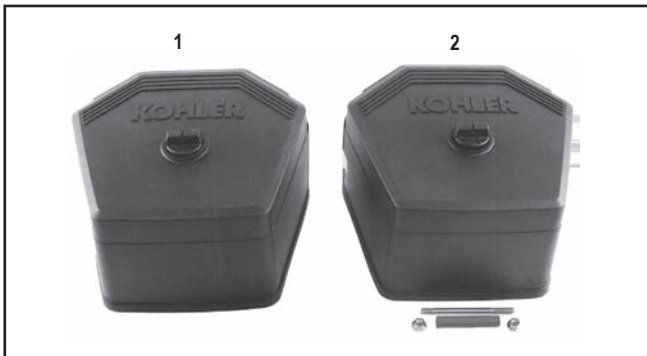

AIR CLEANER COVER KITS COMMERCIAL MOWER

Kit No.	Model	Item
24 743 11-S*	CV17-25/730-740	1
24 743 17-S**	CV17-25/730-740	2
24 743 32-S**	CV26/745	2

Note: Covers include embossed KOHLER name on outside, maintenance instructions on inside (English, Spanish, German, French).

* Cover is made of high-temp material for extreme conditions.

** Same as -11-S kit, but includes stud, seal and nuts for high-moisture conditions preventing water seepage under cover.

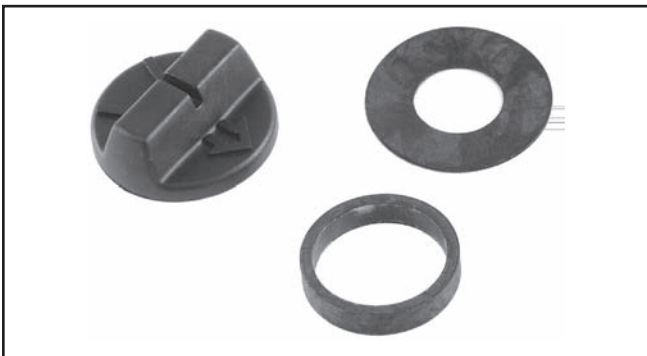

KNOB REPLACEMENT KIT

Kit No.	Description	Model
54 755 01-S	Knob Kit	CH/CV17-26/730-750

CS4-6 MUFFLER

Kit includes muffler and gasket. Use hardware from existing muffler.

Kit No.	Outlet Location	Outlet O.D.	Muffler Length	Outlet Tube Length	Model
63 786 01-S	Throttle Side*	1.0"	9.46"	1.0"	CS4-6

*Outlet is on opposite side of standard muffler location. Also allows for unobstructed PTO face.



COURAGE SINGLE (SV470-620) MUFFLER KIT

Kit includes muffler, gasket, support bracket, hardware and instructions.

Kit No.	Description	Engine Side	Outlet D.B.C.
20 786 02-S***	Muffler Kit	Starter	2.047
20 086 02-S****	Muffler Kit	Starter	2.047
20 755 10-S	Guard Kit*		
12 755 107-S	Guard Kit**		

* Cage open at bottom to avoid interference with deck.

** Cage closed at bottom.

*** Not compliant for California.

**** California compliant muffler.



Shown with optional guard kit.

COURAGE SINGLE EXHAUST FLANGE

For adapting manifold length to customer-supplied exhaust.

Part No.	Description	Model
20 295 01-S	Steel, 0.188 thick	SV470-620



COURAGE SINGLE (SV710-840) MUFFLER KIT

Kit includes muffler, gasket, slip-fit manifolds, and screws. Customer supplies mounting bracket to frame.

Kit No.	Muffler Only	Outlet Location/Direction
32 786 01-S*	32 068 01-S	Bottom/Toward Oil Filter
32 086 03-S**		Bottom/Toward Oil Filter

* Not compliant for California.

** California compliant muffler.



XT-7 (COURAGE) MUFFLER KIT

Kit includes muffler and heat deflector.

Kit No.	Muffler Only	Outlet Location/Direction
14 068 01-S	N/A	Out/Away from Engine

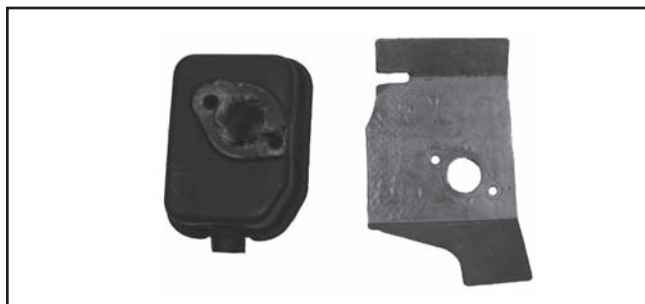

Exhaust

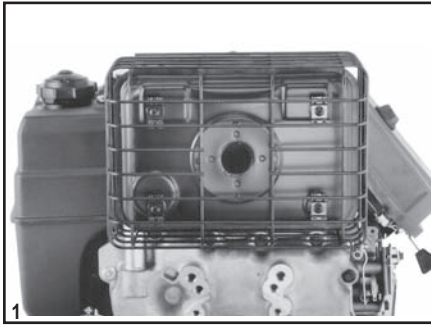

1 Includes Exhaust Deflector (not shown).

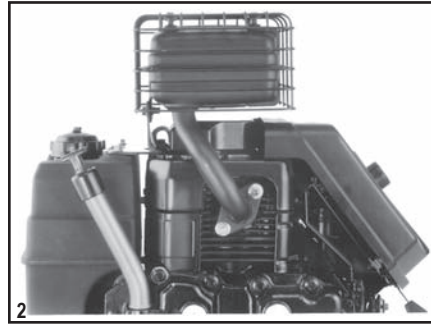

2 Includes Exhaust Deflector (not shown).

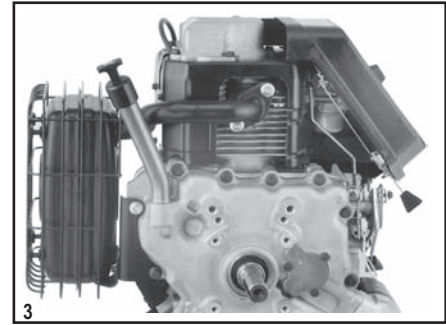

3 Vertical Orientation

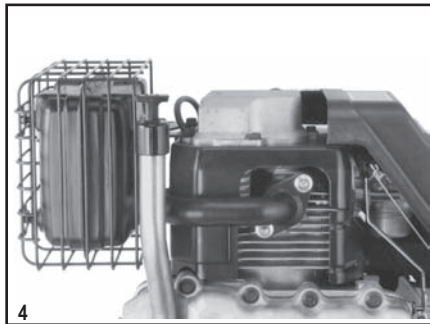

4 Horizontal Orientation



5 EEC Guards*****

PILLOW MUFFLERS & GUARDS (CH11-15)

Muffler kits include oil fill tube/dipstick as pictured . . . to avoid interference with muffler or guard . . . including sealant and a driver to aid in installation. Mufflers have stand offs for attaching optional wire guard. Guard kits do not include muffler.

Part No.	Muff. Only	Description	Engine Side	Outlet D.B.C.	A	B	C	D	E	F	G	H	Item
12 786 09-S*	12 068 26-S	Muffler Kit	PTO	2.047"	13.0"	—	7.0"	—	5.0"	—	4.25"	—	1
12 786 13-S**	12 068 38-S	Muffler Kit	PTO	2.047"	13.0"	—	7.0"	—	5.0"	—	4.25"	—	1
12 755 107-S	—	Guard Kit	PTO	—	—	13.5"	—	6.25"	—	5.5"	—	5.0"	1
12 786 08-S*	12 068 25-S	Muffler Kit	Top	2.047"	17.0"	—	13.25"	—	4.5"	—	—	—	2
12 786 12-S**	12 068 39-S	Muffler Kit	Top	2.047"	17.0"	—	13.25"	—	4.5"	—	—	—	2
12 755 107-S	—	Guard Kit	Top	—	—	17.75"	—	13.125"	—	5.0"	—	—	2
12 786 10-S*	12 068 27-S	Muffler Kit***	Starter, No Tank	2.047"	8.0"	—	1.0"	—	11.0"	—	—	—	3
12 786 14-S**	12 068 41-S	Muffler Kit***	Starter, No Tank	2.047"	8.0"	—	1.0"	—	11.0"	—	—	—	3
12 755 72-S	—	Guard Kit	Starter, No Tank	—	—	8.5"	—	1.5"	—	11.75"	—	—	3
12 786 11-S*	12 068 23-S	Muffler Kit	Starter, No Tank	2.047"	13.0"	—	7.0"	—	10.0"	—	—	—	4
12 786 15-S**	12 068 40-S	Muffler Kit	Starter, No Tank	2.047"	13.0"	—	7.0"	—	10.0"	—	—	—	4
—	**12 068 30-S**	Muffler****	Starter, No Tank	2.047"	13.0"	—	7.0"	—	10.0"	—	—	—	4
12 755 107-S	—	Guard Kit	Starter, No Tank	—	—	13.75"	—	6.25"	—	10.5"	—	—	4
12 755 91-S*****	—	Guard Kit	All	—	—	—	—	—	—	—	—	—	5

* Muffler has no integral port liner. It is usable only on CH11-14 models below Serial No. 2628900001.

** Muffler has integral port liner extending from mounting flange, to interface with cored-out cylinder head. Only for models with Serial No. 2628900001 or higher, which include cored-out cylinder head.

*** Muffler kit not usable on specs with fuel pump.

**** For CH14 LP engines only; includes oxygen sensor port in manifold-to-muffler pipe.

***** Guard kit 12 755 91-S must be used with guard kit 12 755 70-S or 12 755 72-S to comply with EEC standards for avoidance with hot surfaces. Kit includes wire guard and two shields, plus instructions, although all parts are not necessary for every muffler configuration shown. Wire guard covers exhaust manifold; shields prevent contact with manifold periphery.

A — Centerline of crank to top of muffler.

E — Centerline of crank to left edge of muffler.

B — Centerline of crank to top of guard.

F — Centerline of crank to left edge of guard.

C — Centerline of crank to bottom of muffler.

G — From PTO face to farthest edge of muffler.

D — Centerline of crank to bottom of guard.

H — From PTO face to farthest edge of guard.

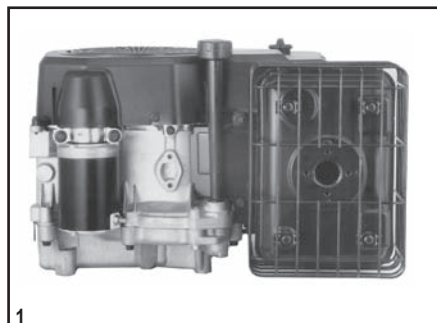

1 Vertical Orientation (Standard)

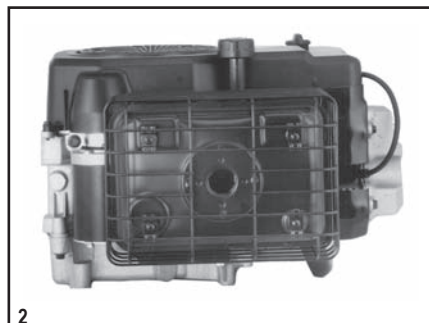

2 Horizontal Orientation

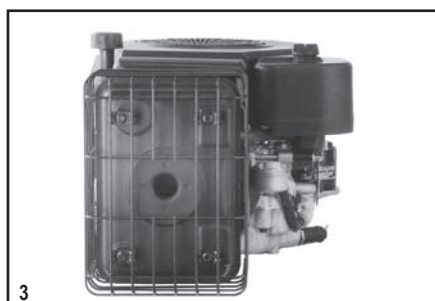

3 Valve Cover Orientation

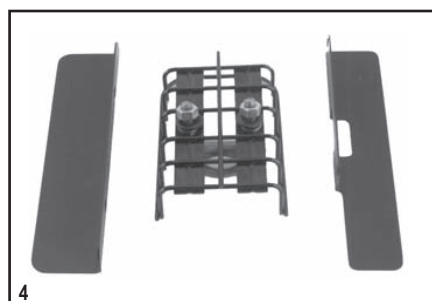

4 EEC Guards*****

PILLOW MUFFLERS & GUARDS (CV11-16/460-493)

Guard kits do not include muffler. **Note:** Mufflers 12 068 54-S and 55-S are exclusive to CV460-493, 12 068 39-S is also useable. No other mufflers are usable on these models.

Part No.	Description	Engine Side	Stand Offs For Guard	Hardware (See note)	Outlet D.B.C.	A	B	C	D	E	F	Item
12 068 21-S*	Muffler (Standard)	Starter	No	1	2.047"	12.0"	—	0.75"	—	4.5"	—	1
12 068 44-S**	Muffler (Standard)	Starter	No	1	2.047"	12.0"	—	10.75"	—	4.5"	—	1
12 068 54-S**	Muffler	Starter	No	1	2.047"	12.47"	—	10.75"	—	4.5"	—	1
12 068 23-S*	Muffler	Starter	Yes	1	2.047"	12.0"	—	10.75"	—	4.5"	—	1
12 068 40-S**	Muffler	Starter	Yes	1	2.047"	12.0"	—	10.75"	—	4.5"	—	1
12 068 30-S**	Muffler****	Starter	Yes	1	2.047"	12.0"	—	10.75"	—	4.5"	—	1
12 068 55-S**	Muffler	Starter	Yes	1	2.047"	12.47"	—	10.75"	—	4.5"	—	1
12 755 107-S	Guard Kit	Starter	—	—	—	—	12.5"	—	11.25"	—	5.25"	1
						(12.97"/460-493)						
12 068 20-S*	Muffler***	Starter	No	2	2.047"	8.0"	—	9.25"	—	3.75"	—	2
12 068 42-S**	Muffler***	Starter	No	2	2.047"	8.0"	—	9.25"	—	3.75"	—	2
12 068 27-S*	Muffler***	Starter	Yes	2	2.047"	8.0"	—	9.25"	—	3.75"	—	2
12 068 41-S**	Muffler***	Starter	Yes	2	2.047"	8.0"	—	9.25"	—	3.75"	—	2
12 755 72-S	Guard Kit	Starter	—	—	—	—	8.5"	—	9.75"	—	4.25"	2
12 068 25-S*	Muffler	Valve	Yes	3	2.047"	2.5"	—	10.5"	—	—	—	3
12 068 39-S**	Muffler	Valve	Yes	3	2.047"	2.5"	—	10.5"	—	—	—	3
12 755 107-S	Guard Kit	Valve	—	—	—	—	3.0"	—	11.0"	—	—	3
12 755 91-S*****	Guard Kit	Items 1 & 2	—	—	—	—	—	—	—	—	—	4

* Muffler has no integral port liner. It is usable only on CV11-14 models below Serial No. 2628900001.

** Muffler has integral port liner extending from mounting flange, to interface with cored-out cylinder head. Only for models with Serial No. 2628900001 or higher, which include cored-out cylinder head.

*** Muffler not usable on specs with fuel pump.

**** For CV14 LP engines only; includes oxygen sensor port in manifold-to-muffler pipe.

***** Guard kit 12 755 91-S must be used with guard kit 12 755 107-S or 12 755 72-S to comply with EEC standards for avoidance with hot surfaces. Kit includes wire guard and two shields, plus instructions, although all parts are not necessary for every muffler configuration shown. Wire guard covers exhaust manifold; shields prevent contact with manifold periphery.

Note: for mufflers 12 068 25-S and 12 068 39-S, only guard 12 755 107-S is necessary for EEC. Mufflers 12 068 20-S, 12 068 21-S, 12 068 42-S and 12 068 44-S do not have weld nuts for guard attachment, so they cannot be made EEC-compliant.

A — Centerline of crank to right edge of muffler.

B — Centerline of crank to right edge of guard.

C — Mounting surface to top of muffler.

D — Mounting surface to top of guard.

E — Centerline of oil fill cap to outer edge of muffler.

F — Centerline of oil fill cap to outer edge of guard.

Mounting Hardware (if not presently on engine)

1 - Order (1) 12 126 71-S bracket, (2) M-645025-S screw, (1) M-545016-S screw, (2) M-841080 nut, (1) X-25-78-S washer. (2) 12 112 20-S spacer (sheet metal valve cover only).

2 - Order 12 755 30-S mounting kit.

3 - Order (1) 12 126 56-S bracket, (2) M-645025-S screw, (2) M-645015-S screw, (1) 12 041 03-S gasket, (2) M-841060-S nut, (2) 12 112 20-S spacer (sheet metal valve cover only).

Exhaust

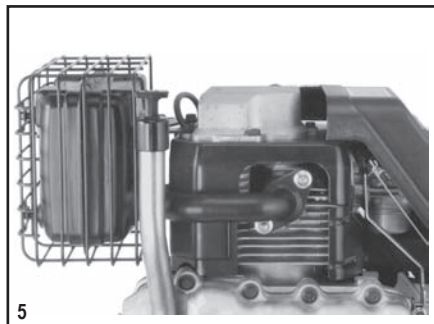
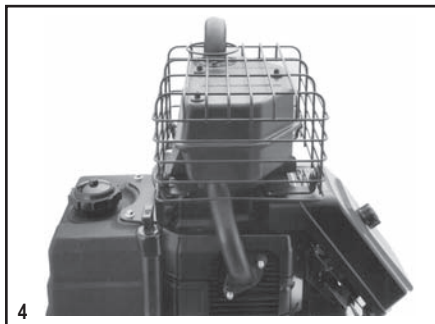
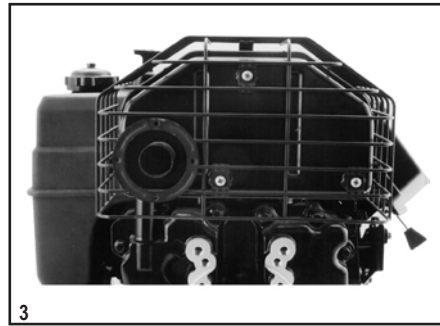
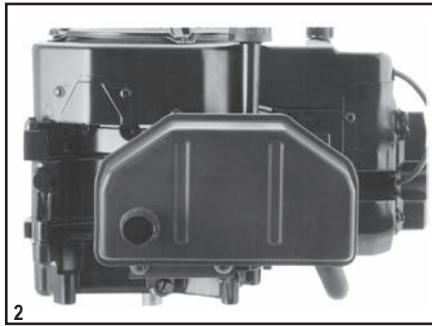
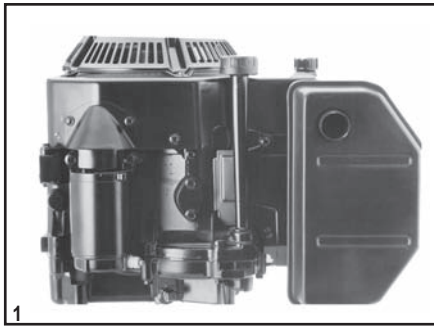

HAM CAN MUFFLERS (CH/CV11-15)

CV Models

Part No.	Description	Outlet O.D.	A	Side	Item
12 068 01-S	Muffler	1.25"	4.94"	Starter	1
12 786 18-S	Mounting Kit*	—	—	Starter	1
12 068 03-S	Muffler	1.25"	6.5"	Starter	2
12 068 35-S	Muffler**	1.25"	6.5"	Starter	2
12 755 30-S	Mounting Kit*	—	—	Starter	2

A — Extends away from blower housing.

* Includes bracketry, gasket, hardware.

** Identical to the -03 muffler, but includes integral port liner extending from the mounting flange. Only ham can muffler usable on CV11-15 models with cored-out cylinder head, Serial No. 26289000001 and higher.

CH Models

Part No.	Description	Outlet D.B.C.	Space	Side	Item
12 068 11-S	Muffler only**	2.047"	B	PTO	3
12 786 04-S	Mounting Kit ***	—	—	PTO	3
12 755 26-S	Guard Kit	—	B	PTO	3
12 068 11-S	Muffler only**	2.047"	C	Top	4
12 786 03-S	Mounting/Guard Kit****	—	C	Top	4
12 068 11-S	Muffler only	2.047"	D	Starter	5
12 786 02-S	Mounting Kit***	—	—	Starter	5
12 755 26-S	Guard Kit	—	D	Starter	5

** Shown with deflector, not included.

*** Includes manifold, bracketry, gaskets, hardware.

**** Includes manifold, bracketry, exhaust deflector, gasket, guard, hardware.

B — From centerline of crank to top of muffler is 12.5"; to top of guard is 13"; to bottom of guard is 6". From PTO face to guard at farthest point is 5.5"; to muffler is 5".

C — From centerline of crank to top of guard is 18.5"; to top of deflector is 20.55".

D — From centerline of crank to left edge of guard is 11.25"; to left edge of muffler is 10.75".

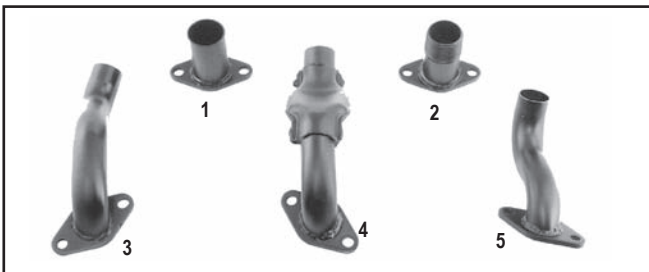

MANIFOLDS

Part No.	Outlet O.D.	Model	For Muffler	Item
12 164 03-S	1.312"	CH11-15	Various	1
12 164 04-S*	—	CH11-15	Pepperpot	2
12 164 05-S**	—	CH11-15	Pepperpot	3
12 382 01-S	1.125"	CH11-15	Ham Can, Top	3
12 382 02-S	1.125"	CH11-15	Ham Can, Starter	4
12 382 03-S	1.125"	CH11-15	Ham Can, PTO	5

* 1.0" N.P.T. external thread.

** Same as 12 382 01-S, except 1.0" N.P.T. external thread.

EXHAUST FLANGE (CH/CV11-15)

For adapting manifold length to customer-supplied exhaust.

Part No.	Description	Model
12 295 01-S	Steel, 0.188" thick	CH/CV11-15

MISCELLANEOUS MUFFLERS

CV Models

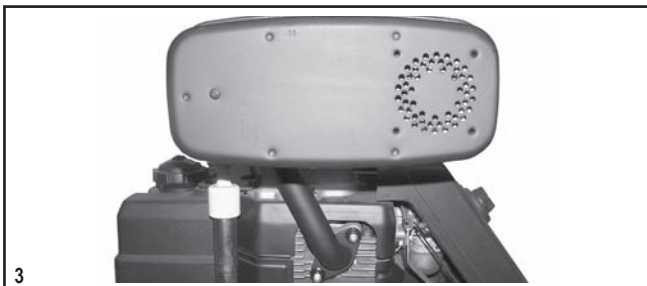
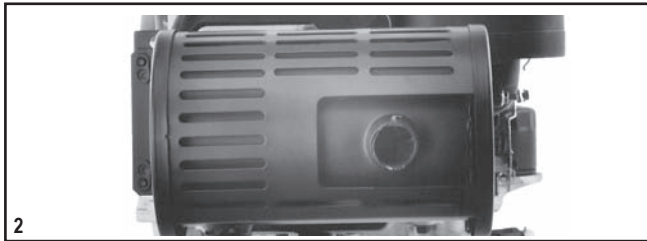
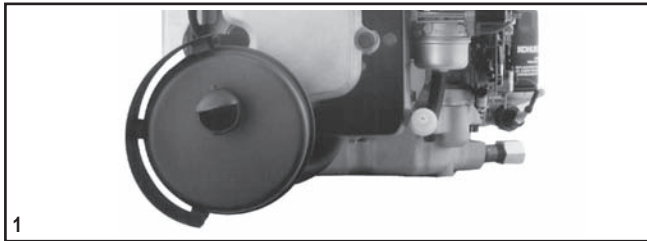

CH Models

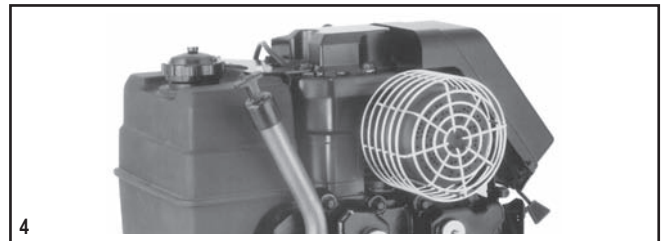
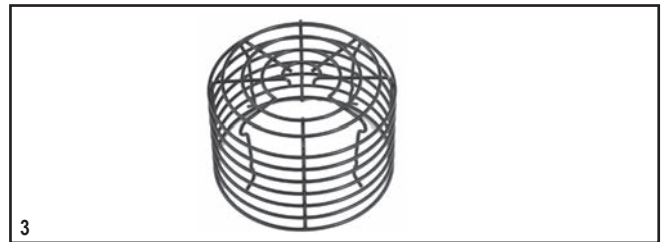
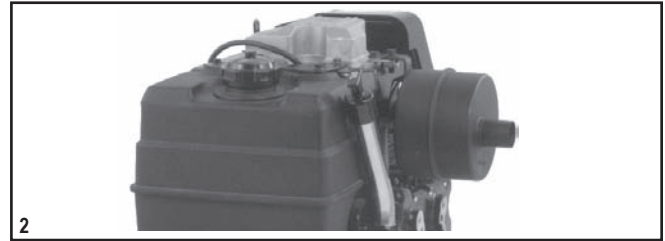

Part No.	Description	Engine Side	Outlet O.D.	Item
12 068 57-S*	Muffler (Aluminized)	Valve Cover	1.25"	1
12 755 20-S**	Muffler Kit	Valve Cover	1.25"	2
12 068 49-S***	Muffler	Valve Cover	1.125"	3

* Includes integral heat shield and exhaust deflector. Also order (2) M-841080-S nut, (1) 12 041 03-S gasket, (1) 25 086 16-S screw, (1) X-25-95-S spacer, (1) X-20-1-S lock washer, (1) 25 100 20-S nut. Muffler extends 5.625" from valve cover. (1) M-645025-S screw, (1) 12 112 20-S spacer (if engine has stamped steel valve cover).

** Includes integral guard. Muffler extends 7" from blower housing.

*** Also order (1) 12 041 03-S gasket, (2) M-841060-S nuts, (1) 12 126 85-S bracket, (2) 12 112 20-S spacers, (4) M-645016 screws, and (2) M-645025 screws.

§ Aluminized steel canister.

Kit No.	Muff. Only	Description (Ideal For)	Engine Side	Item
12 786 16-S*	12 068 58-S [§] (Aluminized)	Round (Compressors)	Top	1
12 786 20-S	12 068 51-S	Round (Press. Washers)	Above PTO	2
12 314 32-S	—	Guard for 1 & 2	—	3
12 786 05-S**	275679-S	Pepperpot-Thread On	Above PTO	4
25 314 01-S	—	Guard only	—	4

* Includes angled oil fill tube and dipstick to clear muffler, plus mounting bracket and hardware. Muffler outlet is 5.5" above valve cover. Outlet O.D. is 1.25".

** Includes muffler, manifold, gasket, hardware. Muffler has 1.0" N.P.T. internal thread. Not usable if engine requires CARB/EPA certification.

§ Aluminized steel canister.

Exhaust

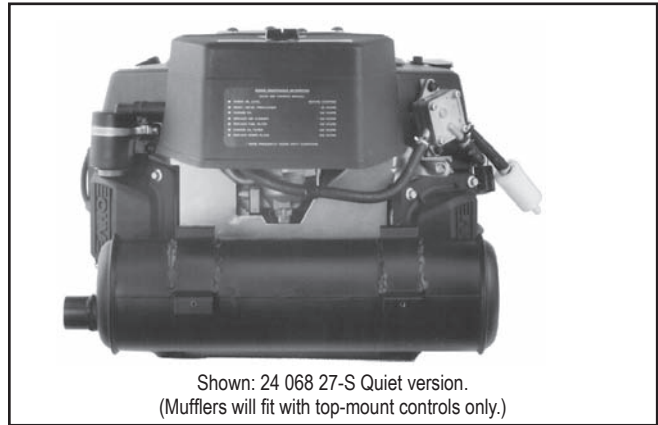

COMMERCIAL MOWER CANISTER MUFFLERS — HEAT SHIELDS REQUIRED. SEE BELOW.

Part No.	Outlet Location/Direction	O.D.	Dia.	Length	Muffler		Model
					A	B	
24 068 09-S	Starter Side/Straight	1.375"	4.0"	12.0"	1.0"	4.75"	CV17-25/730,740,750,LV625-680
24 068 08-S	Filter Side/Straight	1.375"	4.0"	12.0"	1.0"	4.75"	CV17-25/730,740,750,LV625-680
24 068 20-S	Filter Side/Down	1.375"	4.0"	12.0"	1.0"	4.75"	CV17-25/730,740,750,LV625-680
24 068 21-S	Filter Side/Extended	1.375"	4.0"	12.0"	1.0"	4.75"	CV17-25/730,740,750,LV625-680
24 068 58-S [§]	Filter Side/Straight	1.375"	4.0"	12.0"	1.0"	4.75"	CV17-25/730,740,750,LV625-680

*Same as 24 068 08-S, but outlet is higher on end cap to clear obstructions.

[§]Aluminized steel canister.

Note: For mounting, order (2) 24 041 49-S gasket, (2) 24 072 08-S stud, (2) M-641060-S nut, (4) M-841080-S nut.

QUIET CANISTER MUFFLERS — HEAT SHIELDS REQUIRED. SEE BELOW.

These mufflers are larger than those above, and also up to 4 dBA quieter (@3600 RPM, WOT).

Part No.	Outlet Location/Direction	Outlet O.D.	Muffler Dia.	Muffler Length	Muffler		Model
					A	B	
24 068 25-S	Center/Straight	1.375"	4.62"	16.0"	1.0"	5.5"	CV17-25/730,740,750,LV625-680
24 068 27-S	Starter Side/Straight	1.375"	4.62"	16.0"	1.0"	5.5"	CV17-25/730,740,750,LV625-680
24 068 29-S	Filter Side/Straight	1.375"	4.62"	16.0"	1.0"	5.5"	CV17-25/730,740,750,LV625-680
24 068 28-S	Filter Side/Down	1.375"	4.62"	16.0"	1.0"	5.5"	CV17-25/730,740,750,LV625-680
24 068 26-S	Filter Side/Extended	1.375"	4.62"	16.0"	1.0"	5.5"	CV17-25/730,740,750,LV625-680
24 068 58-S	Filter Side/Straight	1.375"	4.62"	16.0"	1.0"	5.5"	CV17-25/730,740,750,LV625-680
24 068 43-S	Center/Straight	1.375"	4.62"	16.0"	1.0"	5.5"	CV26/745EFI
24 068 45-S	Starter Side/Straight	1.375"	4.62"	16.0"	1.0"	5.5"	CV26/745EFI
24 068 47-S	Filter Side/Straight	1.375"	4.62"	16.0"	1.0"	5.5"	CV26/745EFI
24 068 46-S	Filter Side/Down	1.375"	4.62"	16.0"	1.0"	5.5"	CV26/745EFI
24 068 44-S	Filter Side/Extended	1.375"	4.62"	16.0"	1.0"	5.5"	CV26/745EFI

A — Mounting surface to bottom of muffler.

B — Mounting surface to top of muffler.

Note: For mounting, order (2) 24 041 49-S gasket, (2) 24 072 08-S stud, (2) M-641060-S nut, (4) M-841080-S nut.



HEAT SHIELDS FOR CANISTER MUFFLERS

Kohler requires a heat shield between muffler and air cleaner.

Part No.	Designed for Mufflers
24 281 06-S*	24 068 08-S, 09-S, 20-S, 21-S
24 281 13-S*	24 068 26-S, 27-S, 28-S, 29-S
24 281 14-S*	24 068 25-S
24 281 15-S*	24 068 44-S, 45-S, 46-S, 47-S
24 281 16-S*	24 068 43-S
24 314 51-S**	24 068 58-S

*Order (4) 25 086 40-S screws for mounting heat shield.

**Aluminized steel to match muffler.



1
FLAT AIR CLEANER



2
COMMERCIAL MOWER AIR CLEANER

VERTICAL MUFFLER KITS* (CV17-740,750)

Kit No.	Muff. Only	Location	Outlet D.B.C.	A	B	Item
24 786 13-S	24 068 19-S	Starter Side	3.06"	3.0"	3.5"	1 (Shown)
24 786 14-S	24 068 19-S	Filter Side	3.06"	3.0"	3.5"	1
24 786 15-S	24 068 22-S	Starter Side	3.06"	—	—	2 (Shown)
24 786 16-S	24 068 22-S	Filter Side	3.06"	—	—	2

*Includes muffler, manifold, brackets, heat deflector, clamp, gaskets, and hardware.

A — Extends forward of air cleaner.

B — Extends right (or left) of valve cover.

CROSSOVER MANIFOLDS USED IN KITS ABOVE

Part No.	Outlet Location	Outlet O.D.	Item
24 164 12-S	Starter Side, Down	1.125"	3
24 164 13-S	Filter Side, Down	1.125"	4
24 164 16-S	Starter Side, Up	1.125"	1
24 164 17-S	Filter Side, Up	1.125"	2

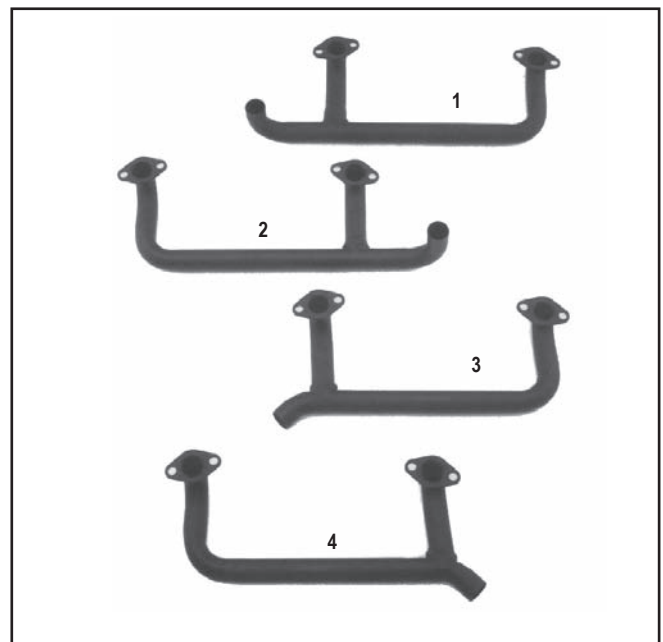

Exhaust

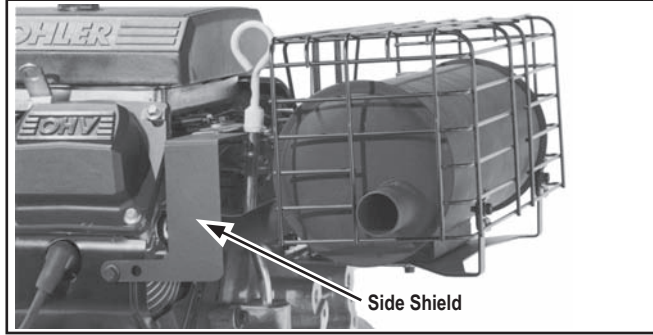
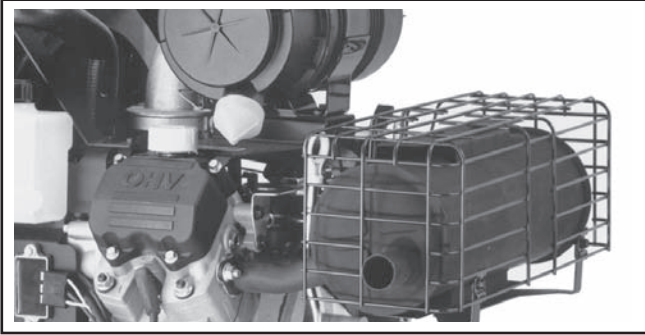

STANDARD PTO-CANISTER MUFFLER & GUARD KITS

(not usable with 1" dia. metal oil fill tube)

Kit No.	Muff. Only	Outlet Location/Direction	Outlet O.D.	AEGIS		COMMAND		Model
				A	B	A	B	
24 786 04-S	24 068 05-S	Center/Straight	1.25"	—	—	4.5"	10.5"	CH18-22
24 786 05-S	24 068 07-S	Filter Side/Straight	1.25"	—	—	4.5"	10.5"	CH18-22
24 786 06-S	24 068 06-S	Starter Side/Straight	1.25"	—	—	4.5"	10.5"	CH18-22
24 786 23-S*	—	Starter Side/45° Down	1.25"	4.3"	10.3"	4.5"	10.5"	CH18-22, CH25/730-740, LH640-755
24 786 10-S**	24 068 12-S	Center/Straight	1.25"	4.3"	10.3"	4.5"	10.5"	CH25/730,740,750, LH640-755
24 786 11-S**	24 068 18-S	Filter Side/Straight	1.25"	4.3"	10.3"	4.5"	10.5"	CH25/730,740,750, LH640-755
24 786 12-S**	24 068 59-S [‡]	Starter Side/Straight (Shown)	1.25"	4.3"	10.3"	4.5"	10.5"	CH25/730,740,750, LH640-755
24 786 26-S	24 068 57-S [‡]	Filter Side/Straight	1.25"	4.3"	10.3"	4.5"	10.5"	CH25/730,740,750, LH640-755
24 755 80-S***	—	Muffler Guard Kit	—	—	—	—	—	CH18-26/730-750, LH640-775
24 755 114-S***	—	Side Shield Kit (2 Shields)	—	—	—	—	—	CH18-26/730-750 only (not LH)
—	24 068 35-S**%	Filter Side/Straight	1.25"	4.3"	10.3"	4.5"	10.5"	CH26/745, LH775
—	24 068 41-S**%	Center/Straight	1.25"	4.3"	10.3"	4.5"	10.5"	CH26/745, LH775
—	24 068 42-S**%	Starter Side/Straight	1.25"	4.3"	10.3"	4.5"	10.5"	CH26/745, LH775

*CH25,26/730-750,LH640-775 require heat shield. See shields below. **Includes heat shield and screws. See shields below.

***When guard kit 24 755 80-S and shield kit 24 755 114-S are used together, they meet EEC (European) standards for avoidance with hot surfaces.

%25 755 36-S mounting kit required for first time installation. [‡]Aluminized steel canister.

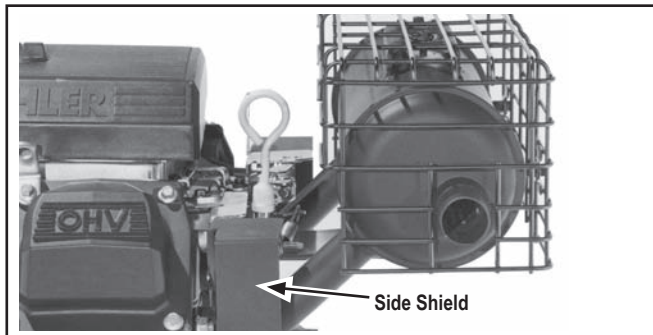
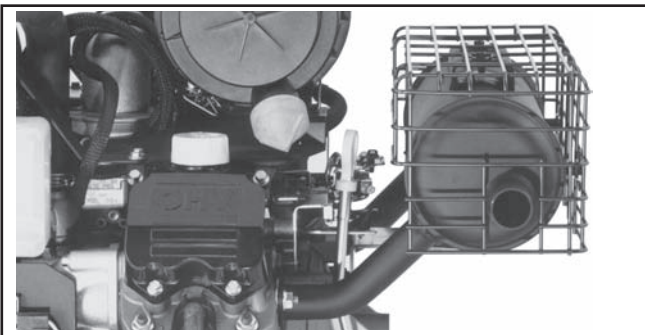

PTO-CANISTER MUFFLER & GUARD KITS (IDEAL FOR GEN SETS)

Mufflers are same size as standard canisters (top of page), but have a raised body to clear the alternator assembly on a generator set. Note that there is no center outlet muffler because it would allow hot exhaust to blow directly at the gen set control box.

Kit No.	Muff. Only	Outlet Location/Direction	Outlet O.D.	AEGIS		COMMAND		Model
				A	B	A	B	
24 786 21-S*	24 068 36-S	Filter Side/Straight	1.25"	6.3"	13.1"	6.5"	13.25"	CH18-25/730,740,750, LH640-755
24 786 22-S*	24 068 37-S	Starter Side/Straight	1.25"	6.3"	13.1"	6.5"	13.25"	CH18-25/730,740,750, LH640-755
24 786 27-S	24 068 51-S	Filter Side/Straight	1.25"	6.3"	13.1"	6.5"	13.25"	CH26/745, LH775
24 755 104-S**	—	Muffler Guard Kit	—	—	—	—	—	CH18-25/730-750, LH640-775
24 755 114-S**	—	Side Shield Kit (2 Shields)	—	—	—	—	—	CH18-25/730-750 only (not LH)

* Includes only screws for attaching heat shield. See shields below. (Required for CH25,26/730-750,LH690-775.)

** When guard kit 24 755 104-S and shield kit 24 755 114-S are used together, they meet EEC (European) standards for avoidance with hot surfaces.

A - Centerline of crank to bottom of muffler. B - Centerline of crank to top of muffler.



HEAT SHIELDS FOR CANISTER MUFFLERS

Part No.	Designed for Mufflers
24 314 04-S*	24 068 12-S, 17-S, 18-S, 36-S, 37-S
24 314 21-S**	24 068 35-S, 41-S, 42-S, 51-S
24 314 50-S*	24 068 57-S

*(4) M-650012 screws for mounting heat shield are included in muffler kits, except for 24 786 23-S which requires screws to be ordered. **Order (4) M-650012-S screws for mounting heat shield. [‡]Aluminized steel to match muffler.

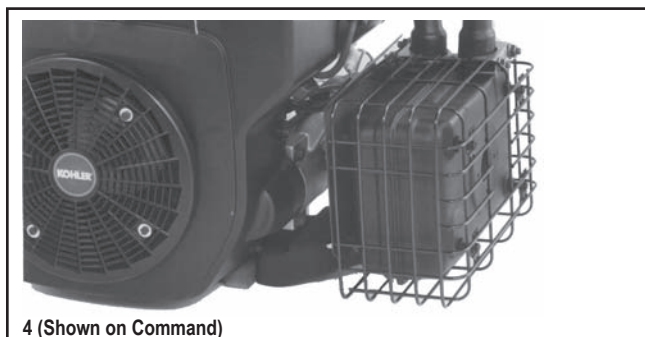

SIDE-MOUNT MUFFLER & GUARD KITS (STANDARD)

(not usable with 1" dia. metal or plastic oil fill tube)

Kit No.	Muff. Only	Location	Outlet D.B.C.	Model	Width By	Extends Engine Item
24 786 08-S	24 068 13-S	Starter Side	2.047"	CH18-22	4.0"	1
24 786 09-S	24 068 14-S	Filter Side***	2.047"	CH18-22*	4.0"	1 (Shown)
24 755 22-S	—	Guard Kit**	—	CH18-22*	4.375"	2
24 786 19-S	24 068 30-S	Starter Side	2.047"	CH25/730,740,750, LH640-755*****	4.25"	3 (Shown)
24 786 20-S	24 068 31-S	Filter Side****	2.047"	CH25/730,740,750, LH640-755*****	5.60"	3
24 755 149-S	—	Guard Kit, Starter Side	—	CH25/730-750, LH640-755	4.25"	4 (Shown)
24 755 151-S	—	Guard Kit, Filter Side	—	CH25/730-750, LH640-755	5.60"	4
24 786 24-S	24 068 54-S	Starter Side	2.047"	CH26,745*****	4.25"	3
24 786 25-S	24 068 55-S	Filter Side****	2.047"	CH26,745, LH775*****	4.25"	3

* Not usable on models with oil cooler.

** Shown on 24 786 09-S Muffler Kit (muffler not included).

*** May also need to order 12 050 14-S oil filter to avoid interference with muffler.

**** Includes 12 050 14-S oil filter to avoid interference with muffler.

*****Kits include muffler and dual manifolds.

SIDE-MOUNT GUARD KITS, EEC (EUROPEAN) COMPLIANT

These kits include guards for the muffler, manifold and exhaust elbow. The guards must be used together to meet EEC standards for avoiding contact with hot surfaces.

Kit No.	Location	Extends Engine Width By	Model
54 755 24-S	Starter Side	4.375"	CH18-22 (Shown)
54 755 25-S	Filter Side	4.375"	CH18-22
24 755 150-S*	Filter Side	4.375"	CH25/730,740,750
LH640-755			
24 755 148-S*	Starter Side	4.375"	CH25/730,740,750
LH640-755			

*Manifold guard is metal mesh, compared to wire form in other kits.

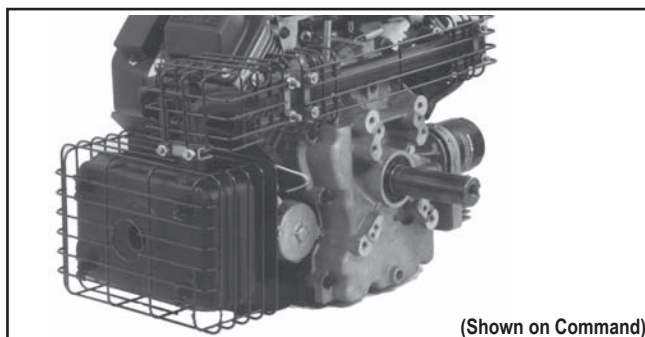

(Shown on Command)

Exhaust

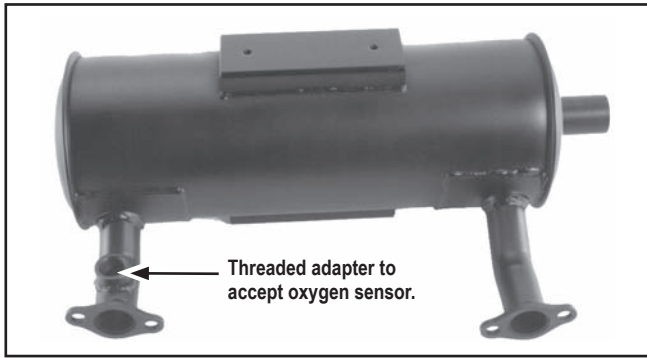

PTO CANISTER MUFFLERS & GUARD (Closed Loop LP Systems)

Mufflers include threaded adapter in filter-side inlet pipe, to accept oxygen sensor for closed loop LP fuel systems.

Outlet				
Kit No.	Muff. Only	Location/Direction	Outlet O.D.	Models
—	24 068 33-S*	Starter Side/Straight	1.25"	CH18-25,730
—	24 068 34-S*	Filter Side/Straight	1.25"	CH18-25,730
24 755 80-S	—	Wire Guard Kit	—	CH18-25,730

* Mufflers include brackets for attaching heat shield (required for CH25).
Order 24 314 04-S heat shield and (4) M-650012-S screws.

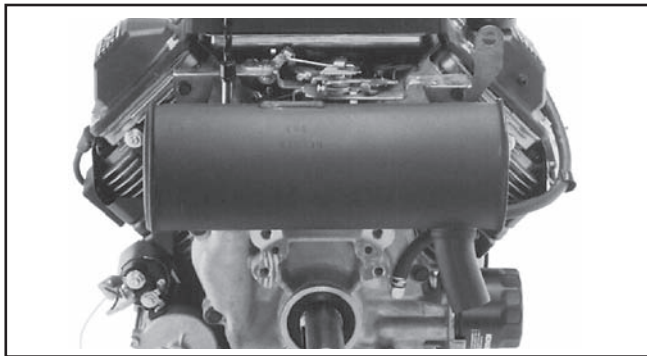

PTO CANISTER MUFFLER (Special Outlet Pointing Down)

Will not accept heat shield or wire guard kit. CARB/EPA compliant on CH18-22 only.

Part No.	Outlet Direction	Outlet O.D.	Models
24 068 11-S	Down	1.375"	CH18-22*

* Application Engineering approval needed for CH25/730-740 and LH640-755 due to smaller muffler volume and potential for higher heat.

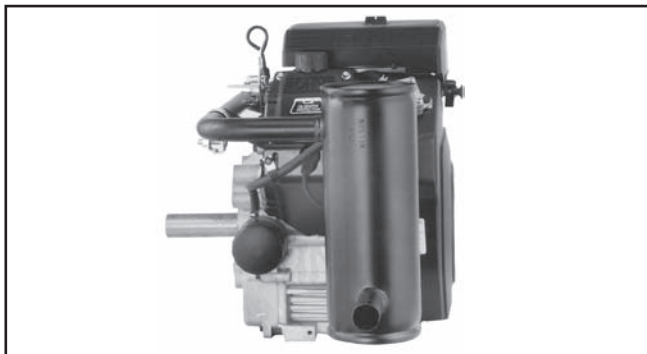

CANISTER MUFFLER (Vertical Orientation)

Available on filter side only (without oil cooler) and as remote. Special shielding is necessary (furnished by customer) to protect the fuel pump. . . whether spec has pulse or mechanical pump. If a mechanical pump is used on starter side, no shielding is necessary.

Part No.	Mounting Location	Outlet O.D.	Models
24 068 15-S*	Remote Mount	1.375"	CH18-22
24 068 16-S**	Filter Side (shown)	1.375"	CH18-22

* Also order (1) 24 164 04 manifold, (2) 24 041 49 gasket, and (4) M-841080 nut.

** Same as above, plus: (1) 12 237 02 clamp, (1) M-839020 screw (bracket to crankcase), and (1) M-651030 screw (bracket to valve cover).

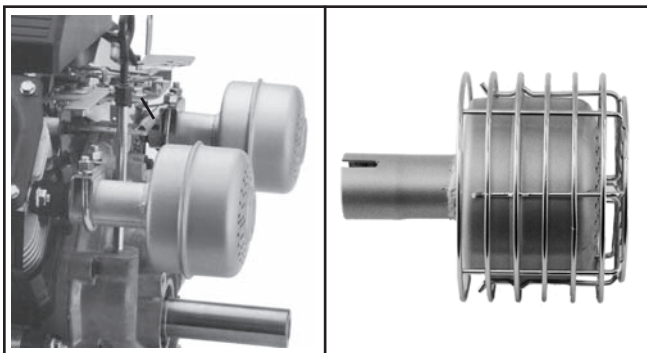

PEPPERPOT MUFFLER & GUARD

Muffler kit includes two mufflers, manifolds and gaskets, plus hardware. Muffler is not usable on engines that must meet CARB/EPA emission regulations, unless approved by Kohler for specific applications.

Part No.	Muffler Only	Description	Models
24 786 07-S	52 068 04-S	Muffler Kit	CH18-25/730-750, LH640
25 314 01-S	—	Guard (order 2)	CH18-25/730-750, LH640



CROSSOVER MANIFOLDS

Part No.	Outlet Location	Outlet	Extends From PTO Face	Model	Item
Single Manifolds					
24 164 04-S	Filter Side	1.11" (O.D.)	0.75" Outside Face	CH18-22	1
24 164 02-S	Filter Side (Fits duct package)	1.11" (O.D.)	2.125" Outside Face	CH18-22	1
24 164 03-S	Starter Side (Fits duct package)	1.11" (O.D.)	2.125" Outside Face	CH18-22	1
24 164 10-S	Starter Side (For side muffler)	1.11" (O.D.)	0.25" Inside Face	CH18-22	1
24 164 11-S	Filter Side (For side muffler)	1.11" (O.D.)	0.25" Inside Face	CH18-22	1
24 164 27-S****	Filter Side	1.24" (O.D.)	0.25" Inside Face	CH25/730-750, LH640-755	1
24 164 28-S****	Starter Side	1.24" (O.D.)	0.25" Inside Face	CH25/730-750, LH640-755	1
24 164 25-S	Center*	1.468" (O.D.)	6.5" Outside Face	CH26/745, LH775	2
Dual Manifolds					
24 164 19-S	Starter Side (For side muffler, cyl. #1)**	1.26" (I.D.)	0.25" Inside Face	CH25/730-750, LH640-755	3
24 164 20-S	Starter Side (For side muffler, cyl. #2)**	1.26" (I.D.)	0.25" Inside Face	CH25/730-750, LH640-755	3
24 164 21-S	Filter Side (For side muffler, cyl. #2)***	1.26" (I.D.)	0.25" Inside Face	CH25/730-750, LH640-755	3
24 164 22-S	Filter Side (For side muffler, cyl. #1)***	1.26" (I.D.)	0.25" Inside Face	CH25/730-750, LH640-755	3

* Includes port for oxygen sensor (24 418 05-S, not included). To be CARB/EPA certified, must have Kohler Application Engineering approval when non-Kohler exhaust components are used.

** Included in the 24 786 19-S side-mount muffler kit.

*** Included in the 24 786 20-S side-mount muffler kit.

**** Will not fit with straight dipstick tube. Offset dipstick tube or kit 24 123 16-S required.

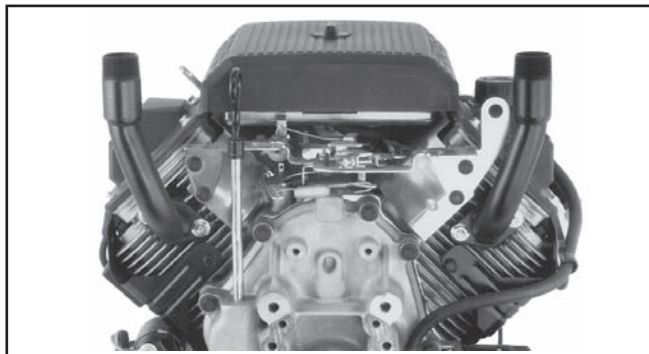

90° MANIFOLD KIT

Kit No.	Fits Muffler	Thread	Model
24 730 01-S	275679-S	1" N.P.T.	CH18-25/730-750, LH640-755

Kit includes (2) elbows, (2) gaskets, (4) nuts. No interference with PTO face.



STRAIGHT COUPLE

Use with 90° manifold kit above or other threaded parts.

Part No.	Description	Thread
24 249 01-S	Straight Couple	1" N.P.S.

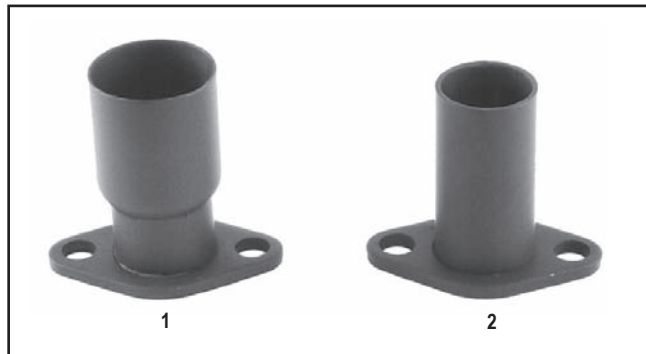

STUB MANIFOLDS

Kit No.	Outlet O.D.	Model	Item
24 164 05-S	1.415"	CH18-25/730-750, LH650-775	1
24 164 07-S	1.125"	CH18-25/730-750, LH650-775	2



EXHAUST FLANGE

For adaptation of customer-supplied exhaust.

Part No.	Description	Model
24 295 01-S	Steel, 0.188" thick	CH/CV17-25/730-750, LH640-775

†Indicates item not usable on engines which are required to meet CARB or EPA emission regulations, unless approved by Kohler for specific applications.

Exhaust

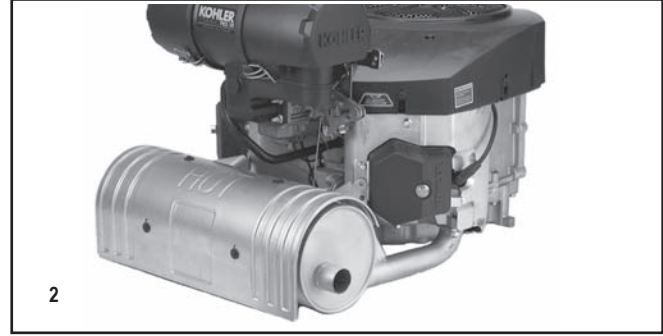
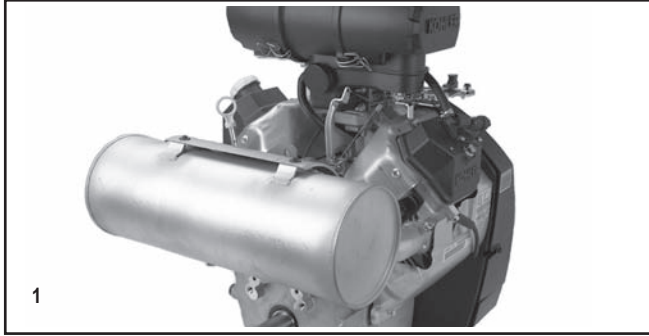

HORIZONTAL MUFFLER KITS*

Kit No.	Muff. Only	Discharge	Outlet O.D.	A	B	Item	Heat Shield (required)
62 786 01-S	62 068 06-S	Center	1.5"	11.75"	4.0"	1	62 314 05-S
62 786 02-S	62 068 05-S	Starter Side	1.5"	11.75"	4.0"	1	62 314 05-S
62 786 03-S	62 068 02-S	Opposite Starter	1.5"	11.75"	4.0"	1	62 314 05-S

*Includes muffler, gaskets, heat shield, and hardware.

A — Centerline of crank to top of muffler.

B — Centerline of crank to bottom of muffler.

VERTICAL MUFFLER KITS*

Kit No.	Muff. Only	Discharge	Outlet O.D.	A	B	Item	Heat Shield (required)
62 786 04-S	62 068 09-S	Center	1.5"	2.68"	4.04"	2	62 314 06-S
62 786 05-S	62 068 08-S	Starter Side	1.5"	2.68"	4.04"	2	62 314 04-S
62 786 06-S	62 068 07-S	Opposite Starter	1.5"	2.68"	4.04"	2	62 314 04-S

*Includes muffler, brackets, gaskets, heat shield, and hardware.

A — Mounting surface to bottom of muffler.

B — Mounting surface to top of muffler.

CROSS OVER MANIFOLDS & MUFFLER

Original Equipment Manufacturer responsible for the original installation and thermal protection.

Kit No.	Model	Description	Location	Outlet O.D.	Inlet I.D.	
62 164 10-S	CH940-1000	Manifold	Non-Starter Side	1.5"		Not Pictured
62 164 11-S	CH940-1000	Manifold	Starter Side	1.5"		Not Pictured
62 068 10-S	CH940-1000	Muffler	—		1.5"	Not Pictured

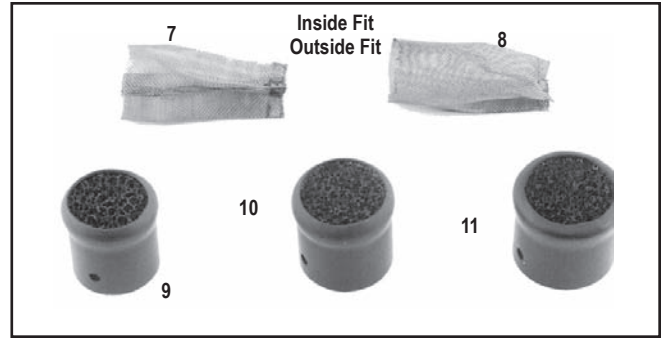
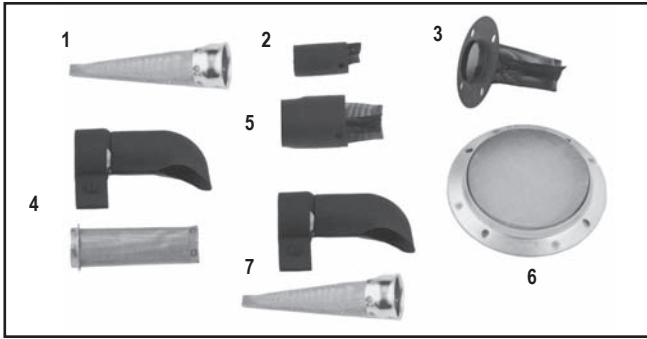

SPARK ARRESTORS

Part No.	Model/HP	HP Rating For U.S.F.S.	Inlet Size	Fits Muffler Outlet	Mounting D.B.C.	Notes	Item
63 189 02-S	CS4-6	6	—	—	—	Already factory-installed on engine	1
63 189 01-S	CS8.5-12	12	—	—	—	Already factory-installed on engine	1
15 189 01-S	CH6	6	0.76" I.D.	0.75" O.D.	—	Includes set screw	2
15 755 16-S*	CH6	6	0.76" I.D.	0.75" O.D.	—	Kit includes 15 189 01-S arrestor (above) and 15 029 02-S adapter (see below)	—
12 189 02-S**	CH/CV11-16/460-493, CH18-25/730-740, LH640-755, SV470-620	27	1.125" O.D.	1.126" I.D.	2.047"	For pillow side muffler	3
24 189 01-S	CH18-26/730-750, LH640-775,	31	1.26" I.D.	1.25" O.D.	—	For canister muffler, inc. deflector	4
25 189 01-S	CH/CV11-16/460-493, CH18-26/730-750, LH640-775	27	1.26" I.D.	1.25" O.D.	—	Includes set screw	5
25 189 02-S	CH/CV17-26/730-750, LH640-775, LV625-680	27	1.39" I.D.	1.375" O.D.	—	Includes set screw	5
25 533 01-S**	CH11-15	23	—	—	3.68"	For 275679-S pepperpot muffler	6
62 189 02-S	CH940-1000	40	—	—	—	Includes set screw	—
62 533 01-S	CH940-1000	40	—	—	—	For canister muffler, inc. deflector	7

* User must weld adapter to muffler outlet. Other end will then accept 15 189 01-S arrestor. Also must cut slot in guard.

** Also order (4) M-545010-S screw (drill 5/32" holes in muffler).

EXHAUST SILENCERS

Part No.	Model/HP	HP Rating For U.S.F.S.	Inlet Size	Fits Muffler Outlet	Notes	Item
52 428 01-S	Varies by outlet size	****	—	1.375" O.D.	Use 52 086 20-S screw	7
12 755 35-S	Varies by outlet size	****	—	1.25" O.D.	Includes screw	8
25 755 08-S	Varies by outlet size	****	—	1.25" O.D.	Includes screw	9
25 755 09-S	Varies by outlet size	****	—	1.375" O.D.	Includes screw	10
25 755 10-S	Varies by outlet size	****	—	1.5" O.D.	Includes screw	11

****Not U.S.F.S. approved.

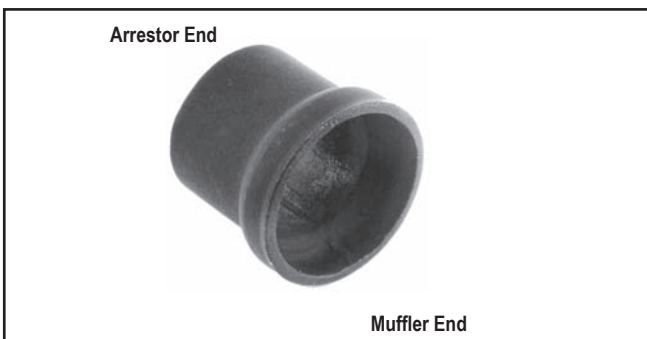

MUFFLER ADAPTER (Muffler to Arrestor)

Part No.	Muffler End I.D.*	Arrestor End O.D.
15 029 02-S	0.76"	0.75"

*Weld to exhaust pipe.

Exhaust

EXHAUST DEFLECTORS

Part No.	Model	Inlet I.D.	Fits Muffler Outlet	Also Order	Item
45 054 21-S	CH/CV17-26/730-750, LH640-775, LV625-680	1.376"	1.375" O.D.	D	1
25 054 05-S	CH/CV940-1000,	1.55"	1.50" O.D.	D	1
12 054 02-S	CV11-16/460-493, CH18-26/730-750, LH640-775	1.26"	1.25" O.D.	B	2
24 265 06-S	CH/CV17-26/730-750, LH640-775, LV625-680	1.39"	1.375" O.D.	B	3
24 265 07-S	CS8.5 (300cc), CS10-12, CH/CV17-26/730-750, LH640-775, LV625-680	1.39"	1.375" O.D.	B	4
63 265 01-S	CS4-6	1.02"	1.0"	E	5
63 265 02-S	CS8.5 (250cc)	1.96"	1.94" O.D.	E	5
24 265 01-S	CH/CV11-16/460-493, CH18-26/730-750, LH640-775	1.25"	1.25" O.D.	—	6
15 265 02-S	CH6	—	1.57" D.B.C.	A	7
12 755 106-S*	CH/CV11-16/460-493, CH18-25/730-740**, LH640-755, SV470-620	—	2.047" D.B.C.	—	8
12 755 28-S*	CH/CV11-16/460-493, CH18-25/730-740, LH640-755, SV470-620	—	2.047" D.B.C.	—	9
25 755 19-S*	CH/CV11-16/460-493, CH18-25/730-740, LH640-755, SV470-620	—	2.047" D.B.C.	—	10
24 755 49-S*	CH/CV17-750	—	3.06" D.B.C.	—	11
24 755 50-S*	CH/CV17-750	—	3.06" D.B.C.	—	12
12 123 08-S	All w/1.25" outlet O.D.	—	1.25" O.D.	C	13
62 265 03-S	CH940-1000.	—	1.50" O.D.	—	—

*Kit includes deflector, screws.

**Minor modifications are needed to muffler guard 24 755 22-S if deflector is used with it.

A — (2) M-556010-S Screw

B — (1) 47 237 04-S Clamp

C — (1) 25 086 40-S Screw

D — (1) 237548-S Clamp

E — (1) 25 086 46-S Screw

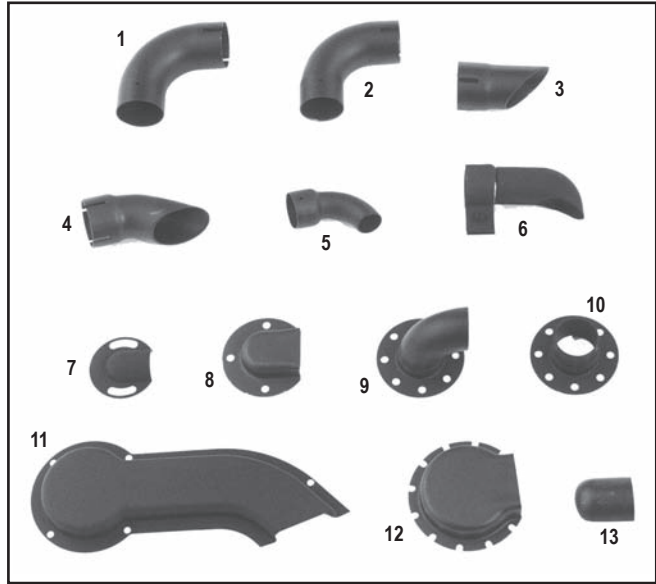

HARDWARE KITS

For attaching mufflers to exhaust outlets.

Kit No.	Model	Includes	Item
12 786 17-S	CH/CV11-16/460-493	2 nuts, 1 gasket	1
25 786 01-S	CH18-26/730-750, LH630-775, TH520-575 w/standard flange nuts (shown)	4 nuts, 2 gaskets	2

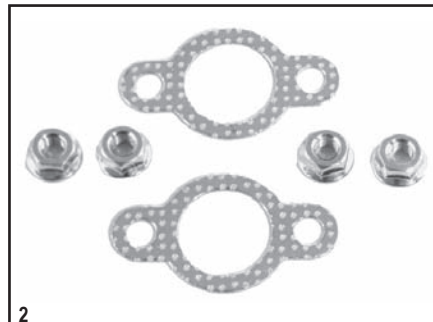

Courage® Single



Silver Graphics
14 113 02-S for XT-7



Primer Decal
14 113 04-S

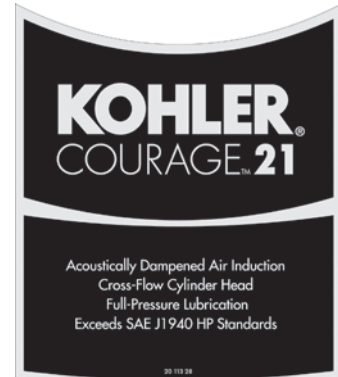

Silver letters/numbers

20 113 09-S - 15 HP
20 113 10-S - 16 HP
20 113 11-S - 17 HP
20 113 12-S - 18 HP
20 113 13-S - 19 HP
20 113 14-S - 20 HP
20 113 28-S - 21 HP
20 113 38-S - 22 HP

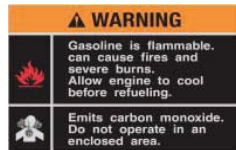

Warning Decal
14 113 03-S



Silver letters/numbers
20 113 29-S (fixed guard)

Courage® Twin



Silver letters/numbers

32 113 02-S - 20 HP
32 113 03-S - 23 HP
32 113 04-S - 25 HP
32 113 24-S - 26 HP
32 113 05-S - 27 HP



Silver letters/numbers

32 113 06-S - 20 HP
32 113 12-S - 22 HP
32 113 07-S - 23 HP
32 113 08-S - 25 HP
32 113 25-S - 26 HP
32 113 09-S - 27 HP



Silver letters/numbers
32 113 10-S wing set



Silver letters/numbers
32 113 11-S - (fixed guard)
Gold letters/numbers
32 113 53-S - (fixed guard)

(Note: All labels shown smaller than actual size.)

Labels

Aegis®

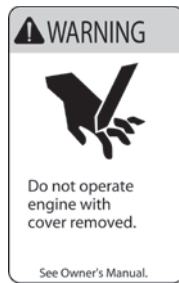

66 113 01-S

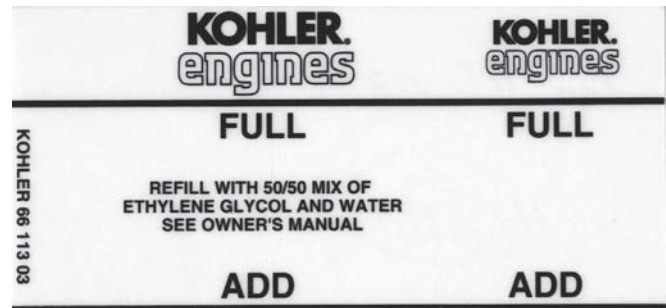

Black on clear, coolant bottle level
66 113 03-S

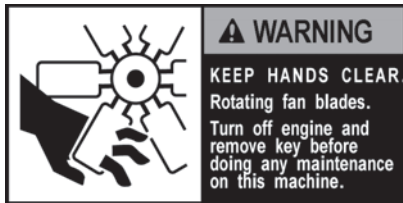

66 113 04-S



Matte gold letters/numbers, blue stripe

- 66 113 12-S – 20 HP
- 66 113 14-S – 24 HP
- 66 113 07-S – 25 HP
- 66 113 15-S – 26 HP
- 66 113 16-S – 28 HP
- 66 113 17-S – 31 HP (EFI)

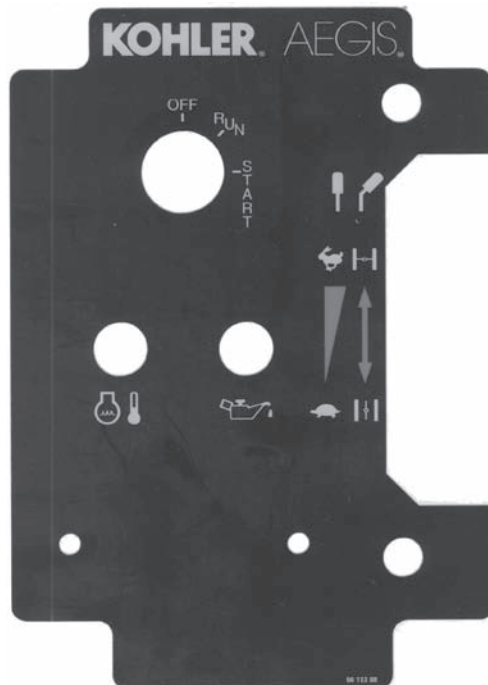

66 113 08-S

(Note: All labels shown smaller than actual size.)

Command PRO CS® Single



Gold letters/numbers

63 113 08-S – 4 HP
63 113 12-S – 6 HP
63 113 13-S – 8.5 HP
63 113 14-S – 10 HP
63 113 05-S – 12 HP
63 113 33-S – 12.75 HP



Gold letters/numbers
63 113 32-S



Gold letters/numbers
63 113 25-S

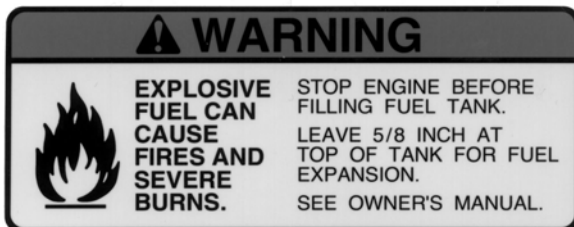

63 113 06-S (All HP)



63 113 11-S – Recoil (4, 6 HP)
63 113 04-S – Recoil (8.5, 10, 12 HP)



Gold letters/numbers
63 113 18-S – 6 HP (2.5" dia.)
63 113 19-S – 8.5 HP (3.25" dia.)
63 113 20-S – 10 HP (3.25" dia.)
63 113 21-S – 12 HP (3.25" dia.)



63 113 10-S – Choke (4, 6 HP)



63 113 02-S – Choke (8.5/300cc, 10, 12 HP)



63 113 01-S – Speed (4-6, 8.5/300cc 10, 12 HP)



63 113 23-S – Speed/Choke (8.5/250cc HP)



63 113 16-S – Ignition (4, 6 HP)



63 113 26-S – Ignition (8.5/250cc HP)



63 113 15-S – Ignition (8.5/300cc, 10, 12 HP)

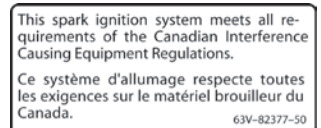

63 113 07-S

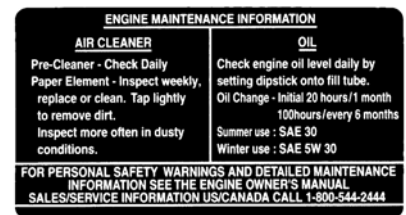

63 113 03-S (All HP)



Gold letters/numbers
66 113 31-S (3.25" dia.)

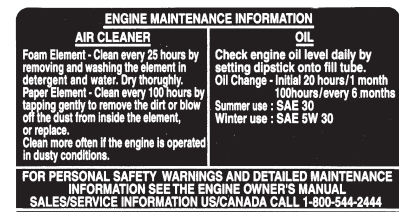

63 113 24-S
(4-6,8.5-12 HP, H.D. Air Cleaner)

(Note: All labels shown smaller than actual size.)

Labels

Command® Single

ENGINE MAINTENANCE INFORMATION

AIR CLEANER PRECLEANER—CHECK DAILY PAPER ELEMENT—INSPECT WEEKLY, REPLACE OR CLEAN, TAP LIGHTLY TO REMOVE DIRT. INSPECT MORE OFTEN IN DUSTY CONDITIONS.	OIL/OIL FILTER CHECK ENGINE OIL LEVEL DAILY BY SETTING DIPSTICK ONTO TUBE. OIL CHANGE – 100 HOURS/ONCE A SEASON. SUMMER—USE SAE 10W30 WINTER—USE SAE 5W30 OIL FILTER CHANGE—200 HOURS/ EVERY OTHER OIL CHANGE.
--	--

FOR PERSONAL SAFETY WARNINGS AND DETAILED MAINTENANCE INFORMATION, SEE THE ENGINE OWNER'S MANUAL.
SALES SERVICE INFORMATION US CANADA CALL 1-800-544-2444

12 113 04 (6-88)

12 113 04-S (100 hr. oil interval, summer 10W-30)

ENGINE MAINTENANCE INFORMATION

AIR CLEANER PRECLEANER—CHECK DAILY PAPER ELEMENT—INSPECT WEEKLY, REPLACE OR CLEAN, TAP LIGHTLY TO REMOVE DIRT. INSPECT MORE OFTEN IN DUSTY CONDITIONS.	OIL/OIL FILTER CHECK ENGINE OIL LEVEL DAILY BY SETTING DIPSTICK ONTO TUBE. OIL CHANGE – 50 HOURS/ONCE A SEASON. SUMMER—USE SAE 10W30 WINTER—USE SAE 5W30 OIL FILTER CHANGE—100 HOURS/ EVERY OTHER OIL CHANGE.
--	---

FOR PERSONAL SAFETY WARNINGS AND DETAILED MAINTENANCE INFORMATION, SEE THE ENGINE OWNER'S MANUAL.

12 113 53 (NOV 93)

12 113 53-S (50 hr. oil interval)

STARTING INSTRUCTIONS

1. PLACE THROTTLE IN CHOKE POSITION.
2. SLOWLY PULL STARTER HANDLE UNTIL JUST PAST COMPRESSION - STOP! RETURN STARTER HANDLE, PULL FIRMLY TO START.

USE SAE 10W30 OIL.
USE OF HEAVIER OIL WILL MAKE STARTING DIFFICULT.

12 113 07-S (Starting)

WARNING

EXPLOSIVE FUEL CAN CAUSE FIRES AND SEVERE BURNS.

STOP ENGINE BEFORE FILLING FUEL TANK.
LEAVE 1 1/4 INCH AT TOP OF TANK FOR FUEL EXPANSION.
SEE OWNER'S MANUAL.

12 113 21-S

STARTING INSTRUCTIONS

1. PLACE THROTTLE IN CHOKE POSITION.
2. SLOWLY PULL STARTER HANDLE UNTIL JUST PAST COMPRESSION - STOP! RETURN STARTER HANDLE, PULL FIRMLY TO START.

STOPPING INSTRUCTIONS

1. MOVE THROTTLE TO MID-RANGE BEFORE STOPPING.
USE SAE 10W30 OIL.
USE OF HEAVIER OIL WILL MAKE STARTING DIFFICULT.

12 113 71-S (Starting/Stopping)



12 113 16-S – white on clear



12 113 25-S



12 113 50-S



12 113 22-S – white on clear



12 113 17-S – white on clear



- Non-PRO, silver on black, red stripe
- | | |
|-----------------------|------------------------|
| 12 113 41-S – 12.5 HP | 12 113 118-S – 17 HP |
| 12 113 42-S – 14 HP | 12 113 113-S – 17.5 HP |
| 12 113 46-S – 15 HP | 12 113 119-S – 18 HP |
| 12 113 117-S – 16 HP | |



- PRO, matte gold letters/numbers, red stripe
- | | |
|------------------------|------------------------|
| 12 113 108-S – 11 HP | 12 113 111-S – 14 HP |
| 12 113 109-S – 12.5 HP | 12 113 112-S – 15 HP |
| 12 113 110-S – 13 HP | 12 113 120-S – 15.5 HP |
| | 24 113 94-S – 18 HP |

(Note: All labels shown smaller than actual size.)

Command® Twin



Non-PRO, silver on black, red stripe

24 113 134-S – 16 HP	24 113 71-S – 22 HP
24 113 32-S – 17 HP	24 113 130-S – 23 HP
24 113 11-S – 18 HP	24 113 131-S – 25 HP
24 113 33-S – 19 HP	24 113 137-S – 26 HP (non-EFI)
24 113 102-S – 21 HP	24 113 132-S – 27 HP
24 113 129-S – 20 HP	24 113 133-S – 28 HP



PRO, matte gold on black
25 113 24-S – 1.625" dia.
25 113 25-S – 2.5" dia.



Non-PRO, silver on black, red circle
24 113 18-S – 1.75" dia.



PRO, matte gold letters/numbers, red stripe

24 113 93-S – 17 HP	24 113 97-S – 25 HP
24 113 94-S – 18 HP	24 113 100-S – 26 HP (EFI)
24 113 95-S – 20 HP	24 113 124-S – 27 HP
24 113 96-S – 22 HP	24 113 125-S – 28 HP (EFI)
24 113 90-S – 23 HP	24 113 143-S – 30 HP



Black on silver, high-temperature material - rear of flat A/C

24 113 88 – 16 HP	24 113 24-S – 22 HP
24 113 99-S – 17 HP	24 113 89-S – 23 HP
24 113 07-S – 18 HP	24 113 34-S – 25 HP
24 113 08-S – 20 HP	24 113 138-S – Plain Silver, no HP
24 113 150-S – 21 HP	



24 113 19-S – 18 HP
24 113 20-S – 20 HP
24 113 83-S – 23 HP
24 113 51-S – 25 HP

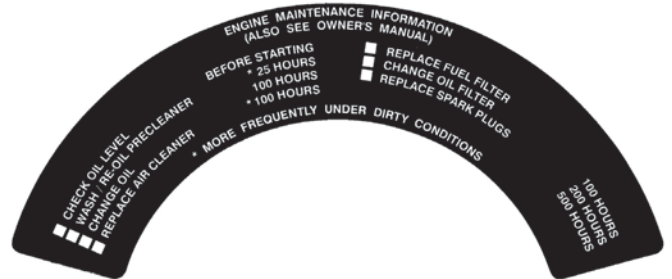

24 113 31-S



24 113 108-S (red on white)



24 113 109-S (blue on white)

(Note: All labels shown smaller than actual size.)

Labels

Command® Twin

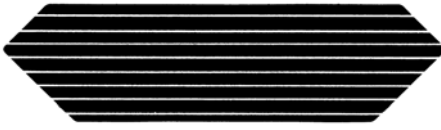

24 113 05-S – Red Stripes
24 113 58-S – Gold Stripes

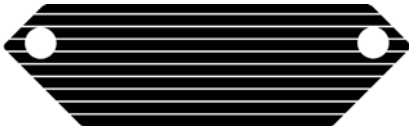

24 113 103-S – Gold Stripes

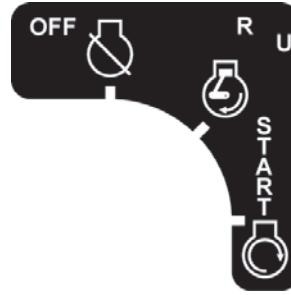

24 113 126-S
For CH Twins with plastic
intake manifold.



24 113 03-S
For CH Twins with aluminum
intake manifold.

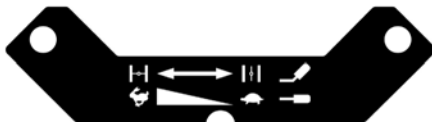

24 113 92-S – New choke/throttle w/o Oil Sentry™



24 113 45-S

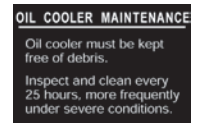

24 113 25-S

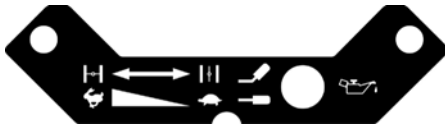

24 113 91-S – New choke/throttle w/Oil Sentry™

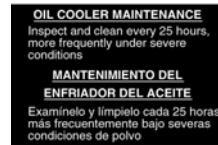

24 113 145-S



24 113 14-S



24 113 127-S – New choke w/o Oil Sentry™



24 113 77-S



24 113 06-S – Old choke/throttle
w/o Oil Sentry™

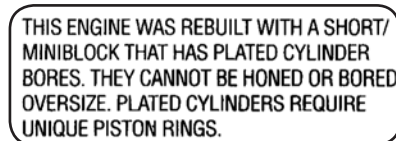

24 113 56-S



24 113 04-S – Old choke/throttle
w/Oil Sentry™



24 113 78-S



24 113 15-S – Old choke

(Note: All labels shown smaller than actual size.)

All Models



25 113 05-S (white on clear)



25 113 23-S



25 113 36-S

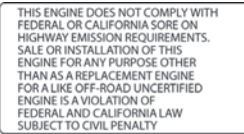

25 113 28-S



25 113 17-S



25 113 16-S

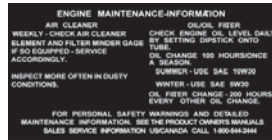

25 113 27-S - H.D. air cleaner



25 113 29-S



25 113 39-S
(clear overlay for name plate)

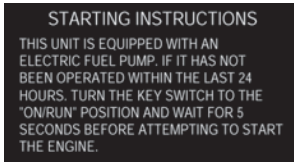

25 113 18-S

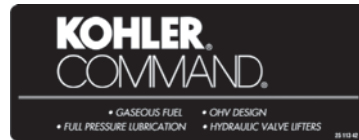

25 113 42-S



PRO_® matte gold on black
25 113 24-S – 1.625" dia.
25 113 25-S – 2.5" dia.

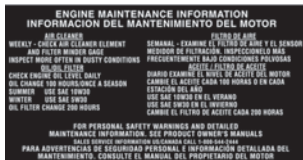

25 113 44-S



41 037 10-S Write-on w/clear protective overlay



25 113 33-S

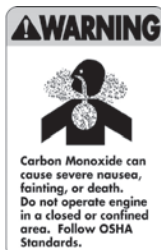

25 113 32-S



25 113 46-S (black on clear)
25 113 47-S (white on clear)

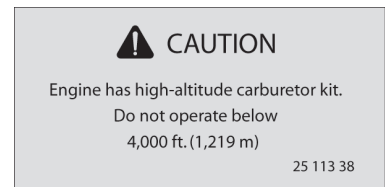

25 113 38-S

(Note: All labels shown smaller than actual size.)

Hang Tags and Cards

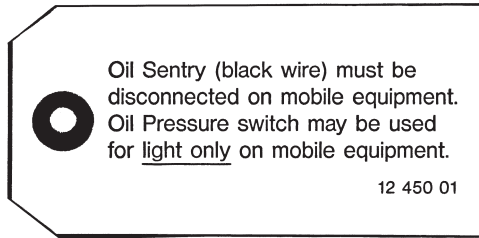

12 450 01-S



25 450 07-S

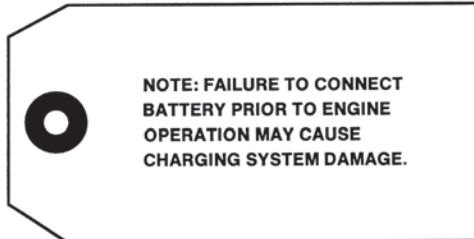

15 450 01-S

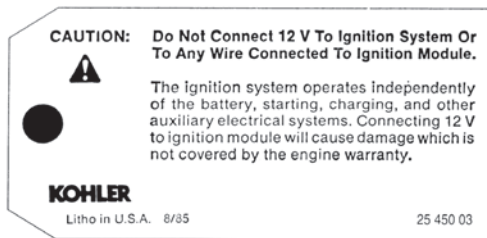

25 450 03-S

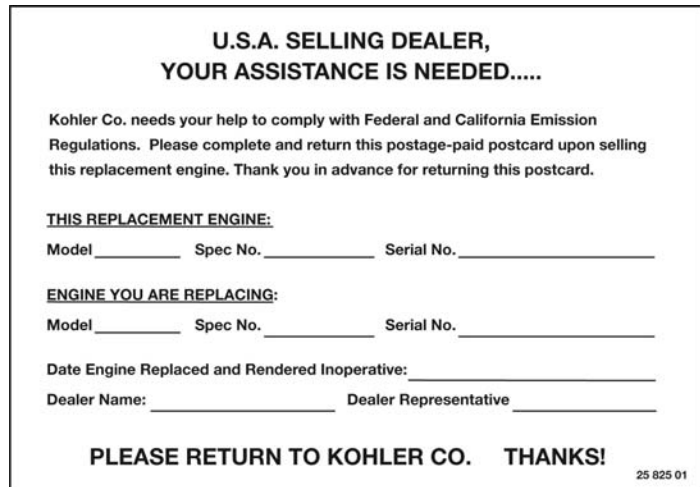

Back Side

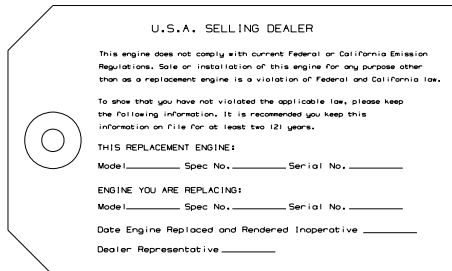

25 450 09-S



Front Side
 25 825 01-S



25 450 05-S

(Note: All hang tags shown smaller than actual size.)



KOHLER[®] ENGINES

FOR SALES AND SERVICE INFORMATION
IN U.S. AND CANADA, CALL **1-800-544-2444**

KohlerEngines.com

ENGINE DIVISION, KOHLER CO., KOHLER, WISCONSIN 53044

FORM NO.:	E-1953-L
ISSUED:	7/06
REVISED:	4/08

LITHO IN U.S.A.