

### FEATURES

- The preferred pump frame in the car wash self-service industry
- Forged brass manifold with an exclusive lifetime warranty
- Large-capacity, die-cast, anodized aluminum oil-bath crankcase
- Over-sized connecting rods for maximum life
- Heavy-duty tapered roller bearing.
- Solid ceramic plungers with continuously lubricated packings
- Unitized stainless steel inlet and discharge valves
- CW24, CW3040 and CW2004 available in left-handed “L” version

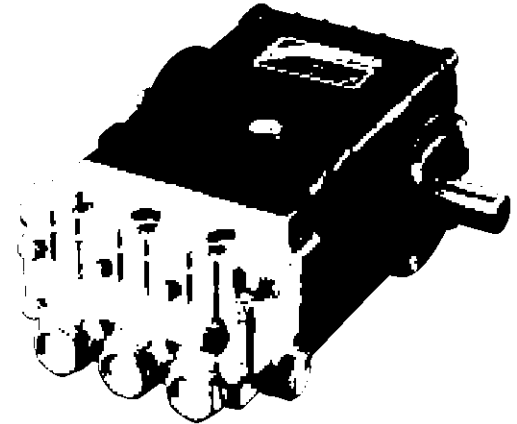

### SPECIFICATIONS

Pump Model	CW2040*	CW24	CW3040	CW2004
Maximum Volume	5.0 GPM @ 1500 PSI, 1250 RPM	5.0 GPM @ 1500 PSI, 1250 RPM	5.0 GPM @ 2500 PSI, 1250 RPM	4.0 GPM
Max. Discharge Pressure	2500 PSI @ 3.0 GPM, 750 RPM	2500 PSI @ 3.0 GPM, 750 RPM	3000 PSI @ 4.0 GPM, 1000 RPM	2000 PSI
Maximum Pump Speed	1000 RPM @ 4.0 GPM, 2000 PSI	1250 RPM @ 5.0 GPM, 1500 PSI	1250 RPM @ 5.0 GPM, 2500 PSI	1750 RPM
Maximum Inlet Pressure	125 PSI			
Maximum Inlet Vacuum	9 ft. water (7.9 in. Hg)			
Bore	.787 in. / 20 mm			
Stroke	.630 in. / 16 mm			.394 in. / 10 mm
Crankcase Oil Capacity	33.8 oz	33.8 oz.	40.6 oz.	33.8 oz.
Maximum Fluid Temp.	165°F			
Inlet Port Thread	1/2-14 BSPP-F			
Discharge Port Thread	3/8-19 BSPP-F			
Shaft Diameter.	(*dual shaft)	.945 in. / 24 mm		
Weight	30 lbs.	30 lbs.	32 lbs.	30 lbs.
Dimensions	11.4 x 10.8 x 6.9 in.	11.4 x 9.2 x 6.9 in.	12.2 x 9.2 x 6.9 in.	11.4 x 9.2 x 7.2 in.

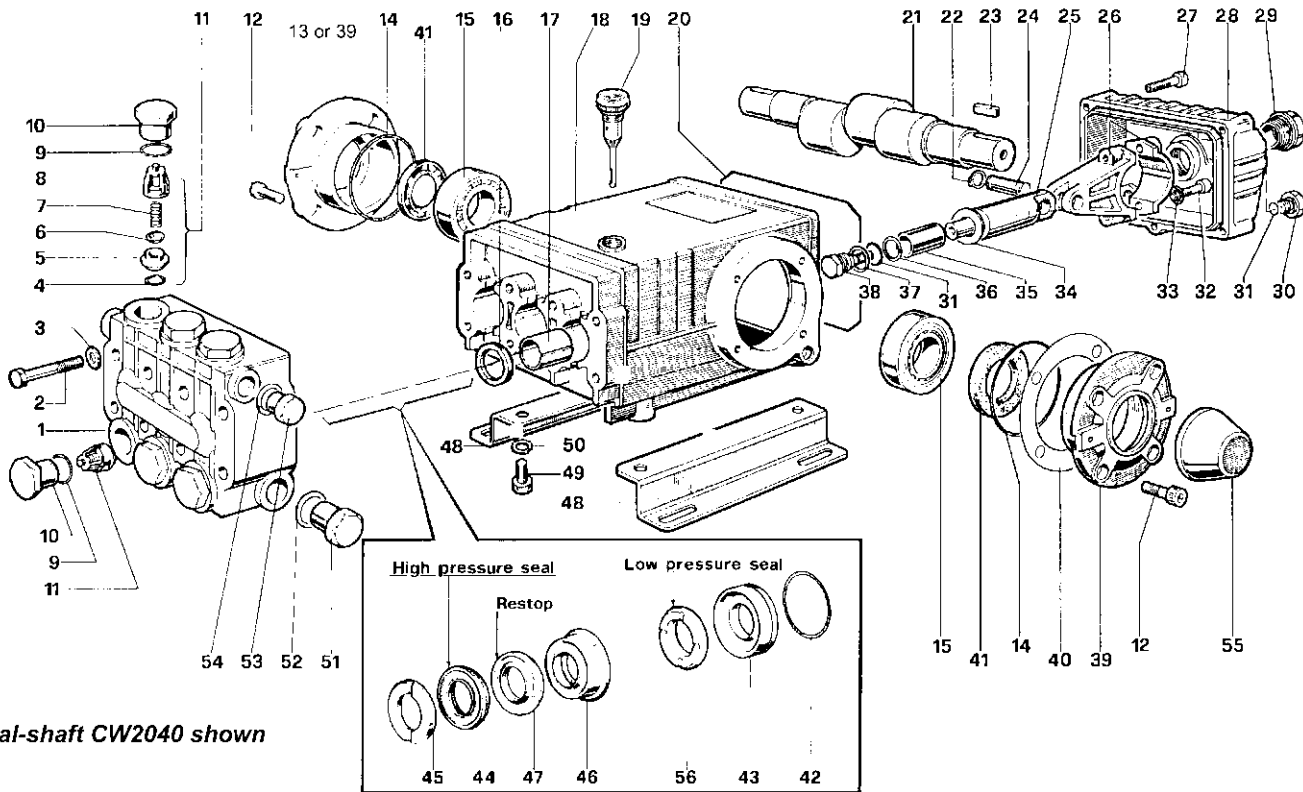

Dual-shaft CW2040 shown

## PARTS LIST

ITEM	PART NO.	DESCRIPTION	KIT NO.	QTY.	ITEM	PART NO.	DESCRIPTION	KIT NO.	QTY.	ITEM	PART NO.	DESCRIPTION	KIT NO.	QTY.
1	47.1208.41	Manifold		1	20	47.2119.84	Cover, Gasket		1	38	47.2195.66	Screw, Plunger	6, 107	3
	47.1201.41	Manifold (CW24)			21	47.0216.35	Crankshaft – dual (CW2040)		1	39	47.1500.22	Cover, Crankcase		2
2	99.3206.00	Screw, M8 x 70		8		47.0200.35	Crankshaft (CW24)			40	97.5678.00	Shim		2
3	96.7020.00	Washer, M8.4		8		47.0217.35	Crankshaft (CW3040)			41	90.1648.00	Seal, Oil	3	2
4	90.3841.00	O-Ring, .674 x .103	K01	6		47.0214.35	Crankshaft (CW2004)			42	90.3616.00	O-Ring, 1.364 x .070	10,9101A,910	3
5	36.2003.66	Seat, Valve	K01	6	22	90.0557.00	Ring, Snap, M12		6	43	47.0809.70	Retainer, Seal, Low Press	10,9101A,910	3
6	36.2001.76	Plate, Valve	K01	6	23	91.4890.00	Key		1	44	90.2705.00	Seal, High Pressure	969,9101A	3
7	94.7376.00	Spring	K01	6	24	97.7380.00	Pin, Wrist		3	45	47.1000.51	Ring, Head, M20	7, 9101A	3
8	36.2002.51	Guide, Valve	K01	6	25	47.0504.54	Guide, Piston		3	46	47.2169.70	Ring, Intermed, M20	71,9101A	3
9	90.3847.00	O-Ring, .797 x .103		4	26	47.0300.01	Rod, Connecting		3	47	90.2704.00	Ring, Restop	71,969,9101A	3
10	98.2220.00	Cap, M24		4	27	99.1837.00	Screw, M6 x 14		5	48	47.2000.74	Rail, Pump		2
11	36.7032.01	Valve Assembly	K01	6	28	47.1603.22	Cover, Crankcase		1	49	99.3644.00	Screw, M10 x 18		4
12	99.3039.00	Screw, M8 x 16		8		47.1600.22	Cover, Crankcase (CW24)			50	96.7106.00	Washer, M10.2		4
13	47.1501.22	Cover, Crankcase (CW2040 has second #39 instead)		1		47.1604.22	Cover, Crankcase (CW3040)			51	98.2176.00	Cap		1
14	90.3913.00	O-Ring, 2.68 x .103		2	29	97.5968.00	Oil Indicator		1	52	96.7514.00	Washer, M21.5		1
15	91.8375.00	Bearing, Roller		2	30	98.2041.00	Cap		1	53	98.2100.00	Cap		1
16	90.1625.00	Seal, Oil	2	3	31	90.3585.00	O-Ring, .426 x .070	6	4	54	96.7380.00	Washer, M17.5		1
17	90.9126.00	Bushing		3	32	99.3099.00	Screw, M8 x 35		6	55	47.2123.51	Shaft Cover, Red (CW2040 only)		1
18	47.0104.22	Crankcase		1	33	96.7014.00	Washer, M8.4		6	56	90.2694.00	Seal, Low Pressure	969,9101A,910	3
	47.0102.22	Crankcase (CW24)			34	96.7286.00	Washer, M14	6, 107	3	Optional				
19	98.2106.00	Oil Dip Stick		1	35	47.0404.09	Plunger, (20 mm)		3	190160	Rail & Coupler Kit (310)			1
					36	90.5067.00	Ring, Back-up	6, 107	3	190161	Rail & Coupler Kit (530)			1
					37	96.7280.00	Washer, M14	6, 107	3					

## REPAIR KITS

KIT NO.	K01	2	3	4	6	7	10	71	969	9101A	910
ITEM NO.s INCLUDED IN KIT	4,5,6, 7,8 (11)	16	41	9, 10	31, 34, 36, 37, 38	45	42,43	46, 47	44,47, 56	42,43,44, 45,46,47, 56	42,43, 56
NUMBER OF ASSEMBLIES IN KIT	6	3	2	6	3	6	3	3	3	1	3
NUMBER OF CYLINDERS KIT WILL SERVICE	6	3	-	3	3	3	3	3	3	1	3

## TORQUE SPECS\*

Position	Ft.-lbs.
2	22.1
10	73.7
12	14.7
27	7.3
29	13.2
30	14.7
32	14.7
38	14.7
49	29.4
51	29.4