

### FEATURES

- Most widely-used pump frame in the touchless carwash industry
- Forged brass manifold with exclusive lifetime warranty
- High flow applications
- Dual manifolds utilizing a common crankcase for efficient performance
- Solid ceramic plungers with continuously lubricated packings
- Unitized stainless steel inlet and discharge valves
- Bronze connecting rods for maximum life



### SPECIFICATIONS

Pump Model	CW1041
Maximum Volume	45.8 GPM
Maximum Discharge Pressure	1000 PSI
Maximum Pump Speed	1180 RPM
Maximum Inlet Vacuum	9 ft. water (7.9 in. Hg)
Bore	1.417 in. / 36 mm
Stroke	0.945 in. / 24 mm
Crankcase Oil Capacity	2 quarts
Maximum Fluid Temperature	165°F
Inlet Port Thread	1-11 NPT-F
Discharge Port Thread	3/4-14 NPT-F
Shaft Diameter.	1.378 in. / 35 mm
Weight	156 lbs.
Dimensions	22.1 x 14.0 x 9.7 in.

### DIMENSIONAL DRAWING

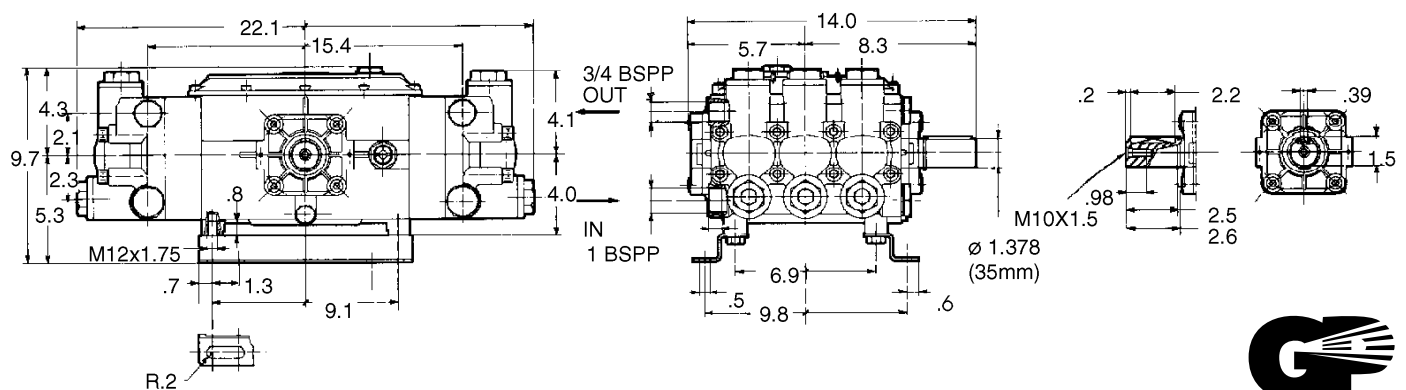

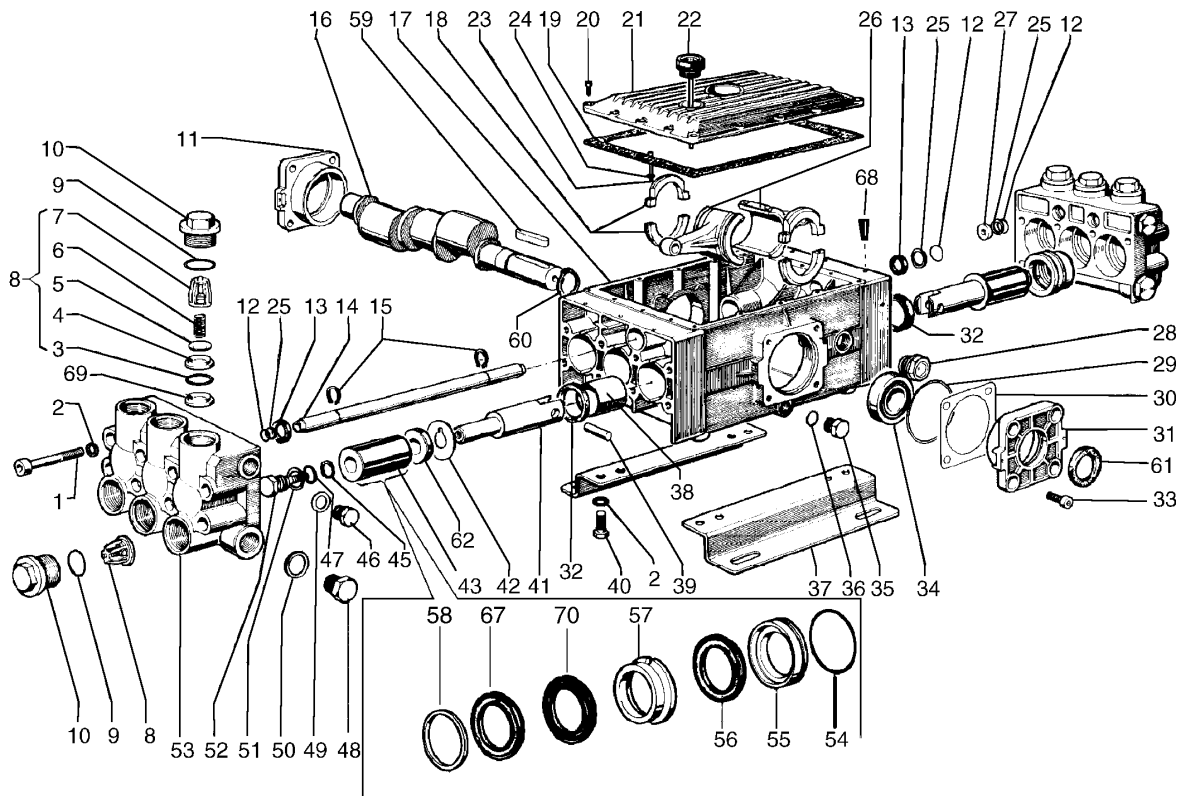

## PARTS LIST

ITEM	PART NO.	DESCRIPTION	KIT NO.	QTY.	ITEM	PART NO.	DESCRIPTION	KIT NO.	QTY.	ITEM	PART NO.	DESCRIPTION	KIT NO.	QTY.
1	99.4418.00	Screw, M12 x 90	16		22	98.2273.00	Oil Dip Stick	1		45	90.5107.00	Ring, Back-up	74	6
2	96.7195.00	Washer, M12	20		23	99.1927.00	Screw, M6 x 35	12		46	98.2265.00	Cap		3
3	90.4059.00	O-Ring, 1.296 x .139	943	12	24	96.6938.00	Washer, M6.4	12		47	90.3841.00	O-Ring, .674 x .103	74	6
4	36.2011.66	Seat, Valve	943	12	25	90.5091.00	Ring, Back-up	4		48	98.2325.00	Cap		2
5	36.2010.76	Valve	943	12	26	77.0302.41	Rod, Connecting	3		49	96.7700.00	Washer, M26.5		3
6	94.7450.00	Spring	943	12	27	77.2203.70	Cap	2		50	96.7870.00	Washer, M33.5		2
7	36.2009.51	Guide, Valve	943	12	28	97.5968.00	Oil Indicator	1		51	96.7555.00	Washer, M22	74	6
8	36.7065.01	Unit, Valve	943	12	29	90.4141.00	O-Ring, 3.359 x .139	2		52	69.2195.66	Bolt, Plunger	74	6
9	90.4065.00	O-Ring, 1.484 x .139	12		30	76.2200.78	Shim	2		53	77.1251.41	Manifold, NPT		2
10	98.2420.00	Cap, M42	12		31	76.1500.22	Housing, Bearing	1		54	90.3903.00	O-Ring, .924 x .103	39,40	6
11	76.1501.22	Cover	1		32	90.1670.00	Seal, Oil	44	6	55	76.0801.70	Retainer, Packing	39,40	6
12	90.3835.00	O-Ring, .594 x .103	4		33	200052	Screw, M10 x 20	8		56	90.2823.00	Packing, Low Pressure	939	6
13	90.1614.00	Seal, Oil	4		34	91.8474.00	Bearing	4		57	69.2170.70	Ring, Intermediate	939,942	6
14	77.2122.93	Tube, Head Conn.	1		35	98.2100.00	Cap	1		58	69.1002.93	Ring, Head	939,41	6
15	90.0605.00	Cir-Clip	2		36	90.3833.00	O-Ring, .549 x .103	1		59	91.4978.00	Key		1
16	76.0211.35	Crankshaft	1		37	76.2000.74	Rail, Pump	2		60	90.0695.00	Cir-Clip		1
17	77.0100.22	Crankcase	1		38	90.9174.00	Bushing	6		61	90.1672.00	Seal, Oil	32	1
18	77.2120.01	Ring, Clamp, Connecting Rod	6		39	97.7400.00	Pin, Plunger	6		62	76.2114.70	Spacer, Plunger		6
19	77.2118.84	Gasket	1		40	99.4266.00	Screw, M12 x 25	4		67	90.2820.00	Packing, High Pressure	939	6
20	99.1867.00	Screw, M6 x 18	16		41	77.0500.54	Guide, Plunger	6		68	600600	Plug, Tapered		6
21	77.2114.22	Cover	1		42	96.7568.00	Washer, M22.3	6		69	96.7570.00	Back-up Ring Valve Seat	943	12
					43	69.0400.09	Plunger, (36 mm)	6		70	90.2818.00	Restop Ring	939	6

## REPAIR KITS

KIT NO.	32	41	44	74	939	940	942	943	100463	100564
ITEM NO.s INCLUDED IN KIT	61	58	32	45, 47, 51, 52	54, 55, 56, 57, 58, 67, 70	54, 55	57	3, 4, 5, 6, 7, (8), 69	54, 55, 56, 57, 58, 67, 70	54, 56, 67, 70
NUMBER OF ASSEMBLIES IN KIT	2	6	3	3	1	3	3	6	6	6
NUMBER OF CYLINDERS KIT WILL SERVICE	-	3	3	3	1	3	3	3	6	6

## TORQUE SPECS\*

Position	Ft./lbs.
1	51.5
10	95.8
20	7.3
23	8.8
28	13.2
33	29.4
40	51.5
46	51.5
48	73.7
52	29.4

\*Decrease torque by 20% if threads are lubricated.