

Direct Drive CP Gearbox

Model

8075

Used on Model 3CP1120G Pump

PUMP FEATURES

- Polished solid ceramic plungers last long and resist abrasion.
- Triplex plunger design provides low pulsation and quiet operation.
- Internally lubricated and cooled packings for extended life.

GEARBOX UNIT FEATURES

- No pulley selection and sizing.
- No belt slippage and adjustment.
- No bulky belt guards.
- No wasted assembly time.
- No multiple source purchases.
- Heavy duty pinion bearing.

GEARBOX SPECIFICATIONS

	U.S. Measure	Metric Measure
Gear Ratio	2.55 to 1	(2.55 to 1)
Max. Horsepower - Gas	See Engine Mfr.	(See Engine Mfr.)
Mounting Face - Gas	3-5/8"	(92 mm)
Gearbox Crankcase Capacity	8.5 oz.	(0.25 L)
Engine Shaft Diameter - Gas	3/4"	(19 mm)
Engine Shaft Length - Gas	2-3/8"	(60 mm)
Max. RPM of Engine	3600 RPM	(3600 RPM)
Weight	5.0 lbs.	(2.26 kg)
Dimensions	5.88 x 3.39 x 5.00"	(149 x 86 x 127 mm)

3CP GEARBOX PUMP SPECIFICATIONS

	U.S. Measure	Metric Measure
Flow	3.5 GPM	(13.2 LM)
Discharge Pressure	2200 PSI	(155 BAR)
Max. Inlet Pressure	Flooded to 60 PSI	(Flooded to 4 BAR)
Maximum RPM	1420 RPM	(1420 RPM)
Bore	0.709"	(18 mm)
Horsepower - Electric	5.3 HP	(5.3 HP)
Stroke	0.512"	(13 mm)
Pump Crankcase Capacity	11.8 oz.	(0.35 L)
Max. Fluid Temperature	160° F	(71°C)
Shaft Diameter	0.650"	(16.5 mm)
Inlet Ports (2)	1/2" NPTF	(1/2" NPTF)
Discharge Ports (2)	3/8" NPTF	(3/8" NPTF)
Weight	19.84 lbs.	(9.0 kg)
Dimensions	9.1 x 8.93 x 5.47"	(231 x 227 x 139 mm)

SERVICING THE GEARBOX

DISASSEMBLY

1. **Completely drain oil** from pump crankcase and gearbox crankcase.
2. Remove four hex head screws which fasten the gearbox to the engine.
3. Remove the four hex head screws which fasten the gearbox to the bearing cover flange and separate gearbox housing from pump.
4. Place gearbox on work surface with **seal facing up**.
5. Remove oil seal by inserting screwdriver between lip of seal and pinion gear. **Seal will be damaged and must be replaced.**
6. Remove large outer retaining ring in groove below oil seal using ring pliers and set aside for re-use.
7. Remove pinion gear assembly. Place gearbox on **engine mount flange** and press bearing out from inside gearbox.

8. Remove bearing from pinion gear by first removing small inner retaining ring with reverse pliers. Set pinion, bearing and ring aside.
9. Remove retaining screw, lockwasher and flat retaining washer.
10. Remove spur gear and key from shaft.

At this point the gearbox has been disassembled. Now begin examination of the gearbox parts for wear and reassembly. While the gearbox is in this state of disassembly, it is advisable to examine your pump for any indication of drive end wear. If any of the following conditions are present, **removal of the bearing cover flange is necessary:**

- Leakage between bearing cover flange and pump crankcase.
- Evidence of water in pump crankcase.
- Evidence of water in gearbox crankcase.

continued on back

“Customer confidence is our greatest asset”

EXPLODED VIEW

Model 8075- Spur Gearbox with Pinion Bearing

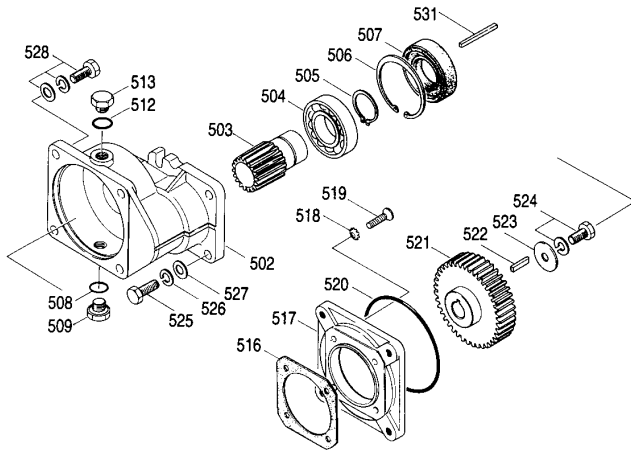

PARTS LIST

ITEM	P/N	MATL	DESCRIPTION	QTY
500	8075	AL	Gear Box	1
502	45085	AL	Housing	1
503	45087	STL	Gear, Pinion	1
504	14488	STL	Bearing, Ball	1
505	47333	STL	Retaining Ring (Inner)	1
506	54673	STL	Retaining Ring (Outer)	1
507	45089	NBR	Seal, Oil, Pinion	1
508	23170	NBR	O-Ring, Drain Plug - 70D	1
509	25625	STCP	Drain Plug (1/4"x19BSP)	1
512	23170	NBR	O-Ring, Drain Plug	1
513	25625	STCP	Plug, Drain (1/4"x19BSP)	1
516	48262		Gasket, Flange	1
517	48261	AL	Flange, Bearing Cover	1
518	210619	STZP	Washer, Toothed (M6)	4
519	45763	STZP	Screw, FH (M6x16)	4
520	44558	NBR	O-Ring, Flange	1
521	44297	STL	Gear, Spur	1
522	57352	STL	Key (M5xM5xM21)	1
523	26118	STZP	Washer, Flat (M8)	1
524	92521	STZP	Screw, HHC Retaining (M8x20)	1
525	44314	STZP	Screw, HH (5/16"-24 x 1")	4
526	12489	STZP	Washer, Flat (M8)	4
527	15845	STZP	Lock Washer (M8)	4
528	92508	STZP	Screw, Sems HHC (M8x25)	4
531	44294	STL	Key (3/16"x3/16"x1-3/4")	1
—	6106	—	Lubricant, Antiseize, 2 ml	1

MATERIAL CODES (Not Part of Part Number): AL=Aluminum
NBR=Medium Nitrile (Buna-N) STL=Steel STCP=Steel/Chrome Plated

Removing Bearing Cover Flange

1. Remove four HHC screws and toothed washers.
2. Tap flange with soft mallet to separate from pump crankcase.
3. Examine pump crankshaft bearing and replace if worn.
4. Examine gasket on outside of bearing cover flange and replace if cut or cracked.
5. Examine o-ring on inside outer groove of bearing cover flange and replace if cut or worn.

Replacing Bearing Cover Flange

1. Line up the four holes and mount gasket on outside of bearing cover flange.
2. Replace o-ring in outer groove of bearing cover flange. Install flange onto pump flush with pump crankcase. **Keep raised threaded mounting holes to front top and bottom rear.**
3. **Install four socket flat head screws and toothed washers and torque per chart.**

RE-ASSEMBLY

1. Insert key into pump crankshaft keyway.
2. Examine spur gear teeth for wear and replace if necessary. Line up **keyway of spur gear with key in pump shaft**. Be certain **long neck** is installed **toward pump crankcase**.
3. Install flat holding washer, lockwasher and retaining screw onto shaft and torque per chart.
4. Examine gearbox crankcase oil drain plugs for any evidence of leaking and replace o-rings if necessary.
5. Examine pinion gear teeth for wear and replace if necessary.
6. Press bearing over pinion until seated on shoulder. Install inner retaining ring on pinion gear and snap into groove.
7. Insert pinion and gear assembly into gearbox housing and press into position until seated on shoulder. **Groove for outer retaining ring must be visible.**
8. Insert large retaining ring into pinion bearing housing and snap into groove.
9. Lubricate I.D. and O.D. of new pinion oil seal. Place oil seal at mouth of pinion bearing housing with **garter spring facing down**. Carefully press seal into position until seated on retaining ring. **Keep seal square in position to avoid inner lip hanging up on pinion gear edge.**
10. Rotate pinion gear so keyway is up. Mount assembled gearbox housing onto pump shaft. NOTE: Carefully match gear teeth and line up mounting holes. **Place engine mounting flange in forward position.**
11. Install four screws to fasten gearbox to bearing cover flange and torque per chart.

LUBRICATION

Fill pump and gearbox with oil before operation. Fill pump with recommended amount, allow to flow into gearbox then add remaining amount to gearbox.

Mounting Pump with Gearbox onto Engine

1. **Rotate crankshaft of engine until keyway is at top.**
2. Insert key into engine keyway and apply Loctite 76764 antiseize lubricant to engine shaft.
3. Line up keyway of pinion gear and engine shaft and carefully slip gearbox onto engine shaft until flush with engine face. Install four hex machined screws and torque per chart.

NOTE: For conversion from standard 3CP1120 pump to 3CP1120G gearbox pump, remove existing bearing cover flange, o-ring and four combination head screws. Replace with new bearing cover flange, flange gasket, four new socket flat head screws and four toothed washers.

TORQUE CHART

	in.lbs.	ft. lbs.	Nm
Flange to Pump	50	4.1	5.6
Pinion Gear Retaining Screw	110	9.1	12.3
Gearbox to Bearing Cover Flange	50	4.1	5.6
Engine Mounting Screws.....	110	9.1	12.3

DIMENSIONAL

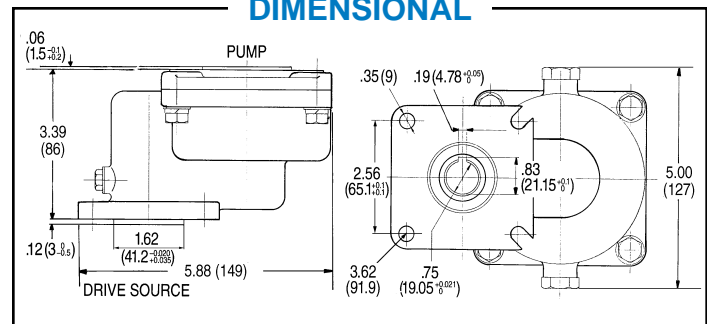

Products described hereon are covered by one or more of the following U.S. patents 3558244, 3652188, 3809508, 3920356, 3930756 and 5035580

Jan 2000 12968

World Headquarters

CAT PUMPS

1681 - 94th Lane N.E. Minneapolis, MN 55449-4324

Phone (612) 780-5440 — FAX (612) 780-2958

e-mail: sales@catpumps.com

www.catpumps.com

International Inquiries

FAX (612) 785-4329

e-mail: intlsales@catpumps.com



"The World's Longest Lasting Pumps"

CAT PUMPS (U.K.) LTD.

1 Fleet Business Park, Sandy Lane, Church Crookham, Fleet

Hampshire GU13 0BF, England

Phone Fleet 44 1252-622031 — Fax 44 1252-626655

N.V. CAT PUMPS INTERNATIONAL S.A.

Heiveldkens 6A, 2550 Kontich, Belgium

Phone 32-3-450.71.50 — Fax 32-3-450.71.51

e-mail: cpi@catpumps.be www.catpumps.be

CAT PUMPS DEUTSCHLAND GmbH

Buchwiese 2, D-65510 Idstein, Germany

Phone 49 6126-93030 — Fax 49 6126-930333

e-mail: catpumps@t-online.de www.catpumps.de