



Direct Drive Gearbox

Models 8051, 8058

Used on Models 51 and 58 Pumps

Models 8061, 8068

Used on Models 34 and 35 Pumps

Models 8065, 8066

Used on Model 45 Pumps

Models 8071, 8078

Used on Models 56, 59, 60, 70 Pumps

PUMP FEATURES

- Polished solid ceramic plungers last long and resist abrasion.
- Triplex plunger design providing low pulsation and quiet operation.
- Internally lubricated and cooled packings for extended life.

GEARBOX UNIT FEATURES

- No pulley selection or adjustment for quick, easy gas engine mounting.
- Totally sealed housing providing independent gearbox lubrication for maximum service life.
- Hardened steel helical design gears for smooth, quiet operation.
- Multiple engine shaft and flange options for flexibility.

COMMON SPECIFICATIONS

	U.S. Measure	Metric Measure
Gear Ratio	2.0384 to 1	(2.0384 to 1)
Mounting Face.....	6-1/2"	(165 mm)
Engine Shaft Diameter	1" 1-1/8"	(25.4 mm) (28.5 mm)
Engine Shaft Length.....	3-1/4"	(82.6 mm)
Gearbox Capacity.....	10 oz.	(0.30 L)
Weight		
8051, 8058, 8061, 8065, 8068....	4.2 lbs.	(1.90 kg)
8071, 8078	7.5 lbs.	(3.40 kg)
Dimensions.....	6.42 x 4.53 x 8.19" (163x115x208 mm)	

“Customer confidence is our greatest asset”

SPECIFICATIONS

Model 34G1 [34 Pump, 8061 G.B.]

Model 34G118 [34 Pump, 8068 G.B.]

	U.S. Measure	Metric Measure
Flow	4.0 GPM	(15 L/M)
Discharge Pressure	2000 PSI	(140 BAR)
Inlet Pressure	Flooded to 60 PSI	(Flooded to 4 BAR)
Maximum Pump RPM.....	1725 RPM	(1725 RPM)
Maximum Engine RPM.....	3515 RPM	(3515 RPM)
Bore	0.787"	(20 mm)
★Horsepower-Electric	5.5 HP	(5.5 HP)
Stroke	0.394"	(10 mm)
Pump Crankcase Capacity	18 oz.	(0.55 L)
Weight	24.3 lbs.	(11.0 kg)
Dimensions with G.B.	11.5 x 10.98 x 8.19"	(292 x 279 x 208 mm)

See Models 30, 31, 34, 35 data sheet for pump information.

Model 35G1 [35 Pump, 8061 G.B.]

Model 35G118 [35 Pump, 8068 G.B.]

	U.S. Measure	Metric Measure
Flow	5.0 GPM	(19 L/M)
Discharge Pressure	1500 PSI	(105 BAR)
Inlet Pressure	Flooded to 60 PSI	(Flooded to 4 BAR)
Maximum Pump RPM.....	1725 RPM	(1725 RPM)
Maximum Engine RPM.....	3515 RPM	(3515 RPM)
Bore	0.787"	(20 mm)
★Horsepower-Electric	5.1 HP	(5.1 HP)
Stroke	0.472"	(12 mm)
Pump Crankcase Capacity	18 oz.	(0.55 L)
Weight	24.3 lbs.	(11.0 kg)
Dimensions with G.B.	11.5 x 10.98 x 8.19"	(292 x 279 x 208 mm)

See Models 30, 31, 34, 35 data sheet for pump information.

Model 45G1 [45 Pump, 8065 G.B.]

Model 45G118 [45 Pump, 8066 G.B.]

	U.S. Measure	Metric Measure
Flow	4.5 GPM	(17 L/M)
Discharge Pressure	3500 PSI	(245 BAR)
Inlet Pressure	Flooded to 60 PSI	(Flooded to 4 BAR)
Maximum Pump RPM.....	1645 RPM	(1645 RPM)
Maximum Engine RPM.....	3353 RPM	(3353 RPM)
Bore	0.630"	(16 mm)
★Horsepower-Electric	10.8 HP	(10.8 HP)
Stroke	0.708"	(18 mm)
Pump Crankcase Capacity	18 oz.	(0.55 L)
Weight	25.3 lbs.	(11.5 kg)
Dimensions with G.B.	12.0 x 10.98 x 5.5"	(345 x 279 x 139 mm)

See Model 45 data sheet for pump information.

Model 51G1 [51 Pump, 8051 G.B.]

Model 51G118 [51 Pump, 8058 G.B.]

	U.S. Measure	Metric Measure
Flow	4.8 GPM	(18 L/M)
Discharge Pressure	3000 PSI	(210 BAR)
Inlet Pressure	Flooded to 60 PSI	(Flooded to 4 BAR)
Maximum Pump RPM.....	1765 RPM	(1765 RPM)
Maximum Engine RPM.....	3600 RPM	(3600 RPM)
Bore	0.630"	(16 mm)
★Horsepower-Electric	9.8 HP	(9.8 HP)
Stroke	0.728"	(18.5 mm)
Pump Crankcase Capacity	25 oz.	(0.75 L)
Weight	30.7 lbs.	(13.9 kg)
Dimensions with G.B.	13.58 x 10.75 x 8.19"	(345 x 273 x 208 mm)

See Models 53, 58, 55, 51 data sheet for pump information.

Model 56G1 [56 Pump, 8071 G.B.]

Model 56G118 [56 Pump, 8078 G.B.]

	U.S. Measure	Metric Measure
Flow	8.0 GPM	(30 L/M)
Discharge Pressure	1800 PSI	(125 BAR)
Inlet Pressure	Flooded to 60 PSI	(Flooded to 4 BAR)
Maximum Pump RPM.....	1760 RPM	(1760 RPM)
Maximum Engine RPM.....	3590 RPM	(3590 RPM)
Bore	0.708"	(18 mm)
★Horsepower-Electric	9.9 HP	(9.9 HP)
Stroke	0.945"	(24 mm)
Pump Crankcase Capacity	25 oz.	(0.75 L)
Weight	36.8 lbs.	(16.7 kg)
Dimensions with G.B.	13.9 x 10.75 x 18.9"	(353 x 273 x 208 mm)

See Models 56, 57, 59, 60 data sheet for pump information.

Model 58G1 [58 Pump, 8051 G.B.]

Model 58G118 [58 Pump, 8058 G.B.]

	U.S. Measure	Metric Measure
Flow	5.0 GPM	(19 L/M)
Discharge Pressure	2500 PSI	(175 BAR)
Inlet Pressure	Flooded to 60 PSI	(Flooded to 4 BAR)
Maximum Pump RPM.....	1570 RPM	(1570 RPM)
Maximum Engine RPM.....	3200 RPM	(3200 RPM)
Bore	0.708"	(18 mm)
★Horsepower-Electric	8.6 HP	(8.6 HP)
Stroke	0.669"	(17 mm)
Pump Crankcase Capacity	25 oz.	(0.75 L)
Weight	30.7 lbs.	(13.9 kg)
Dimensions with .B.....	13.58 x 10.75 x 8.19"	(345 x 273 x 208 mm)

See Models 53, 58, 55, 51 data sheet for pump information.

Model 59G1 [59 Pump, 8071 G.B.]

Model 59G118 [59 Pump, 8078 G.B.]

	U.S. Measure	Metric Measure
Flow	5.5 GPM	(21 L/M)
Discharge Pressure	3500 PSI	(245 BAR)
Inlet Pressure	Flooded to 60 PSI	(Flooded to 4 BAR)
Maximum Pump RPM.....	1570 RPM	(1570 RPM)
Maximum Engine RPM.....	3200 RPM	(3200 RPM)
Bore	0.708"	(18 mm)
★Horsepower-Electric	13.2 HP	(13.2 HP)
Stroke	0.728"	(18.5 mm)
Pump Crankcase Capacity	25 oz.	(0.75 L)
Weight	36.8 lbs.	(16.7 kg)
Dimensions with G.B.	13.9 x 10.75 x 8.19"	(353 x 273 x 208 mm)

See Models 56, 57, 59, 60 data sheet for information.

Model 60G1 [60 Pump, 8071 G.B.]

Model 60G118 [60 Pump, 8078 G.B.]

	U.S. Measure	Metric Measure
Flow	4.5 GPM	(17 L/M)
Discharge Pressure	4000 PSI	(275 BAR)
Inlet Pressure	Flooded to 60 PSI	(Flooded to 4 BAR)
Maximum Pump RPM.....	1570 RPM	(1570 RPM)
Maximum Engine RPM.....	3200 RPM	(3200 RPM)
Bore	0.708"	(18 mm)
★Horsepower-Electric	12.3 HP	(12.3 HP)
Stroke	0.591"	(15 mm)
Pump Crankcase Capacity	25 oz.	(0.75 L)
Weight	36.8 lbs.	(16.7 kg)
Dimensions with G.B.	13.9 x 10.75 x 8.19"	(353 x 273 x 208 mm)

See Models 56, 57, 59, 60 data sheet for pump information.

Model 70G1 [70 Pump, 8071 G.B.]

Model 70G118 [70 Pump, 8078 G.B.]

	U.S. Measure	Metric Measure
Flow	4.5 GPM	(17 L/M)
Discharge Pressure	5000 PSI	(345 BAR)
Inlet Pressure	Flooded to 40 PSI	(Flooded to 2.8 BAR)
Maximum Pump RPM.....	1700 RPM	(1700 RPM)
Maximum Engine RPM.....	3465 RPM	(3465 RPM)
Bore	0.551"	(14 mm)
★Horsepower-Electric	15.4 HP	(15.4 HP)
Stroke	0.945"	(24 mm)
Pump Crankcase Capacity	25 oz.	(0.75 L)
Weight	43.6 lbs.	(19.8 kg)
Dimensions with G.B.	14.02 x 10.75 x 8.19"	(356 x 273 x 208 mm)

See Model 70 data sheet for pump information.

SERVICING THE GEARBOX

DISASSEMBLY

1. **Completely drain lube** from gearbox housing.
2. Remove the four HHC screws which fasten the gearbox to the engine.
3. Remove the four HHC screws which fasten the gearbox to the bearing cover flange and separate gearbox housing from pump.
4. Place gearbox housing on work surface with **seal facing up**.
5. Remove pinion oil seal by inserting screwdriver between pinion gear and inner lip of seal and pry out. **Seal will be damaged and must be replaced.**
6. Remove large retaining ring will be positioned below the pinion seal locked into the retaining ring groove. Remove using retaining ring pliers and set aside for re-use.
7. Remove the pinion gear and bearing. Turn gearbox housing over onto **engine mount flange surface**. Bearing is pressed into position so it is necessary to press pinion and bearing out from rear. Set gearbox housing aside.
8. Remove bearing from pinion gear. Using reverse pliers remove retaining ring from groove on pinion gear and press bearing from pinion. Set aside pinion, bearing and retaining ring.
9. Remove hex machined retaining screw, lockwasher and flat holding washer from center of helical drive gear on pump shaft.
10. Slip helical drive gear from crankshaft.
11. Remove key from keyway in pump crankshaft.

At this point the gearbox has been disassembled. Now begin examination of the gearbox parts for wear and reassembly.

While the gearbox is in this state of disassembly, it is advisable to examine your **pump** for any indication of drive-end wear.

If any of the following conditions are present, **removal of the bearing cover flange** is necessary. **Only trained technicians should service drive end.**

- Leakage between bearing cover flange and pump crankcase.
- Evidence of water in pump crankcase.
- Evidence of water in gearbox crankcase.

NOTE: If removal of bearing cover flange is necessary, completely drain oil from crankcase of pump.

REMOVING BEARING COVER FLANGE

1. Remove the HSH screws, lockwashers and washers from bearing cover flange.
2. Tap flange with soft mallet to separate from pump crankcase.
3. Examine pump bearing and replace if worn.
4. Examine oil seal in bearing cover flange and replace if worn.
5. Examine gasket on **outside** of bearing cover flange and replace if cut or cracked.

6. Examine o-ring on **inside** outer groove of bearing cover flange and replace if cut or worn.

If further pump servicing is needed, refer to your pump service manual, and Tech Bulletin 035 on "Servicing Crankcase Section".

REPLACING BEARING COVER FLANGE

1. Line up the four holes and mount gasket on outside of bearing cover flange. Note: Models 56, 59, 60 and 70 have dual bearings and eight screws.
2. Press new seal into bearing cover flange after **exercising caution not to cut seal on keyway edge**.
3. Line up the inside mounting holes on bearing cover flange with the holes on the pump. **Keep the two outer "flanged" mounting holes to the top rear and lower front.**
4. Apply Loctite-242 to the threaded area of screws before replacing. Torque per chart.

REASSEMBLY

1. Insert key into pump crankshaft keyway until flush with end of shaft.
2. Examine helical drive gear teeth for wear and replace if necessary. Line up keyway on gear with pump shaft keyway and key and slide onto shaft.
3. Install flat holding washer, lockwasher and retaining screw onto shaft and torque per chart.
4. Examine gearbox oil gauge and oil drain plug for any evidence of leaking and replace o-ring and gasket if necessary.
5. Examine pinion bearing for wear and replace if necessary.
6. Examine pinion gear teeth for wear and replace if necessary.
7. Press bearing over pinion gear until seated on shoulder. (Models with dual bearings; press first bearing on until seated; then second bearing until seated up to first bearing.)
8. Install retaining ring on pinion gear and **snap into groove**.
9. Insert pinion and gear assembly into gearbox housing and press into position until seated on shoulder. **Groove for large retaining ring must be visible.**
10. Insert large retaining ring into pinion bearing housing and snap into groove.
11. Lubricate I.D. and O.D. of new pinion oil seal. Place oil seal at mouth of pinion bearing housing with **garter spring facing down**. Carefully press seal into position until seated on retaining ring. **Keep seal square in position to avoid inner lip hanging up on** pinion gear edge.
12. Rotate pinion gear so keyway is up. Mount assembled gearbox housing onto pump shaft with helical drive gear. NOTE: Carefully match gear teeth and line up mounting holes. **Place engine mounting flange in forward position.**
13. Install the screws to fasten gearbox to bearing cover flange. Torque per chart.

MOUNTING PUMP WITH GEARBOX ONTO ENGINE

1. **Rotate crankshaft of engine until keyway is at top.**
2. Insert key into keyway and generously apply Loctite 76764 antiseize lubricant to engine shaft.
3. Line up keyway of pinion gear and engine shaft and carefully slip gearbox onto engine shaft until flush with engine face. Install four hex machined screws. Torque per chart.
NOTE: Due to varying engine shaft lengths it may be necessary to install a small **spacer** on each of the four (4) hex **machined screws** between gearbox flange and engine face.
4. **Before starting operation**, fill gearbox housing to oil gauge dot with 80-90 weight **gear lube** and fill crankcase of pump to oil gauge dot with CAT PUMPS Special Premium Grade Non-detergent Oil.

FIELD CONVERSION FROM STANDARD PUMP

To convert from a standard pump to a gearbox pump, remove the existing bearing cover, gasket and four combination head screws. Replace with new gearbox bearing cover flange, gasket, and new hex socket flat head screws.

The bearing for the 51, 56, 58, 59 and 60 pumps is a tapered roller bearing with outer race. Remove the standard bearing cover from the pump. Remove outer race from bearing cover by gently pounding on work surface to unseat. Then use a bearing puller tool to pull race from bearing cover. **Next press outer race into gearbox bearing cover flange.** Be certain race is completely seated in flange before mounting onto pump.

TORQUE CHART

Description	Thread	Tool	Torque
Gearbox Housing to Bearing Cover Flange	M8	13 mm	70 in. lbs. (8 Nm)
Bearing Cover Flange to Pump (M6)	M6	4 mm	70 in. lbs. (8 Nm)
Bearing Cover Flange to Pump (M8)	M8	5 mm	125 in. lbs. (15 Nm)
Drive Gear Retaining Screw	M8	13 mm	110 in. lbs. (12 Nm)
Engine Mounting Screw	3/8-16	14 mm	110 in. lbs. (12 Nm)

DIMENSIONAL

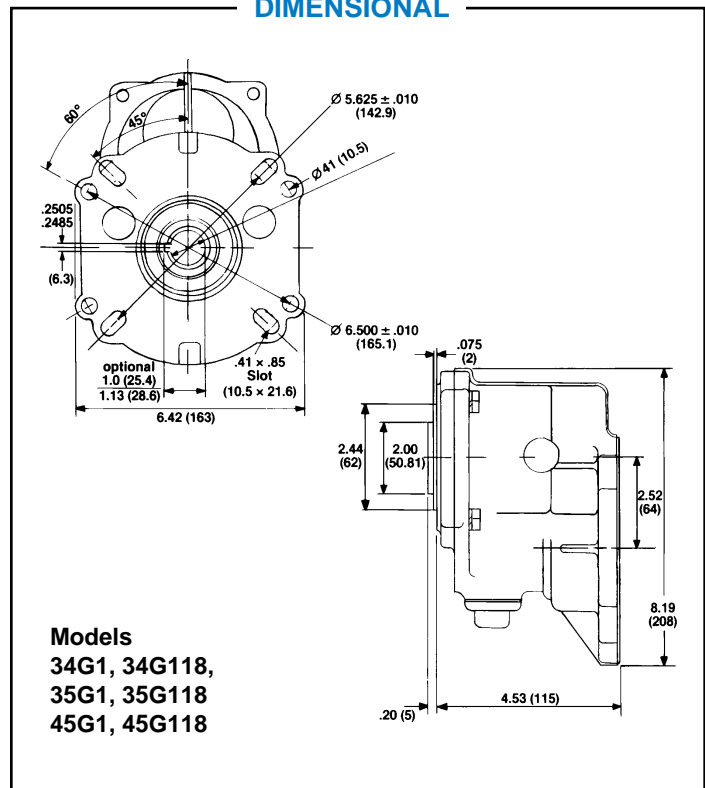

DIMENSIONAL

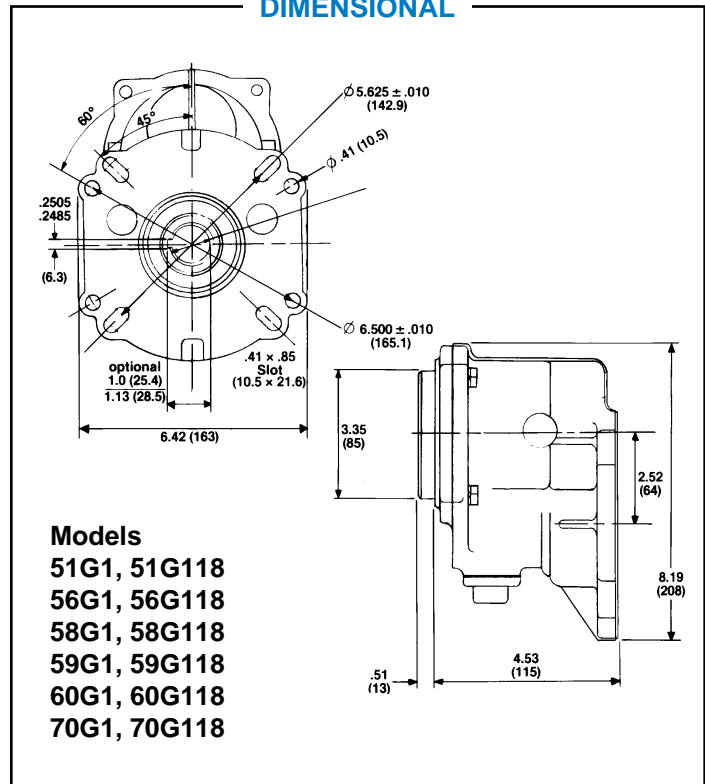

Products described hereon are covered by one or more of the following U.S. patents 3558244, 3652188, 3809508, 3920356, 3930756 and 5035580

Mar 2000 3007

World Headquarters

CAT PUMPS

1681 - 94th Lane N.E. Minneapolis, MN 55449-4324

Phone (763) 780-5440 — FAX (763) 780-2958

e-mail: sales@catpumps.com

www.catpumps.com

International Inquiries

FAX (763) 785-4329

e-mail: intlsales@catpumps.com



“The World’s Most Dependable Pumps”

CAT PUMPS (U.K.) LTD.

1 Fleet Business Park, Sandy Lane, Church Crookham, Fleet

Hampshire GU13 0BF, England

Phone Fleet 44 1252-622031 — Fax 44 1252-626655

N.V. CAT PUMPS INTERNATIONAL S.A.

Heiveldkens 6A, 2550 Kontich, Belgium

Phone 32-3-450.7150 — Fax 32-3-450.7151

e-mail: cpi@catpumps.be www.catpumps.be

CAT PUMPS DEUTSCHLAND GmbH

Buchwiese 2, D-65510 Idstein, Germany

Phone 49 6126-93030 — Fax 49 6126-930333

e-mail: catpumps@t-online.de www.catpumps.de