

8 Frame Block-Style Stainless Steel Plunger Pump

**Standard
Model**

781

**Flushed
Model**

781K

FEATURES

Superior Design

- Triplex plunger design gives smoother liquid flow.
- Inlet and discharge valve assemblies interchangeable for easier maintenance.
- Oil bath crankcase assures optimum lubrication.
- Close tolerance concentricity of the ceramic plunger maximizes seal life.
- **Standard Models:** Lo-Pressure Seals and V-Packings are completely lubricated and cooled by the liquid being pumped.
- **Flushed Models:** Special ported inlet manifold permits liquid to cool or flush between V-Packings and Lo-Pressure Seals providing protection against high temperatures or contaminating pumped liquids.

Quality Materials

- All 316 SSL valves and seats for extended valve life.
- 316 SSL block-style manifolds for strength and corrosion resistance.
- Special concentric, high density, polished, graphite impregnated, solid ceramic plungers are abrasion resistant and result in extended seal life.
- Specially formulated, CAT PUMP exclusive, V-Packings offers unmatched performance and seal life.
- Die cast aluminum crankcase provides high strength, minimum weight and precision tolerance control.
- Chrome-moly crankshaft gives unmatched strength and surface hardness.
- Oversized crankshaft bearings with greater capacity means longer bearing life.

Easy Maintenance

- Wet-end is easily serviced without entering crankcase, requiring less time and effort.
- Preset packings mean no packing gland adjustment is necessary, reducing maintenance costs.

⚠ WARNING

All systems require both a primary pressure regulating device (i.e., regulator, unloader) and a secondary pressure safety relief device (i.e., pop-off valve, safety valve). Failure to install such relief devices could result in personal injury or damage to the pump or to system components. CAT PUMPS does not assume any liability or responsibility for the operation of a customer's high pressure system.

SPECIFICATIONS

	U.S. Measure	Metric Measure
Flow.....	4.5 GPM	(17 L/M)
Pressure Range.....	100 to 5000 PSI	(7 to 345 BAR)
Inlet Pressure Range*	Flooded to 40 PSI	(Flooded to 2.8 BAR)
RPM	1700 RPM	(1700 RPM)
Bore.....	0.551"	(14 mm)
Stroke.....	0.945"	(24 mm)
Crankcase Capacity	25 oz.	(0.75 L)
Max Liquid Temperature	160°F	(71°C)
Inlet Ports (2)	1/2" NPTF	(1/2" NPTF)
Flushing Ports (2)*	1/4" NPTF	(1/4" NPTF)
Discharge Ports (2).....	3/8" NPTF	(3/8" NPTF)
Shaft Diameter - Single End.....	0.945"	(24 mm)
Weight.....	48.1 lbs.	(21.8 kg)
Dimensions.....	13.15 x 8.19 x 6.06"	(334 x 208 x 154 mm)

*"K" models have special inlet ports for cooling/flushing, containment of hazardous liquids and high inlet pressure. Consult CAT PUMPS for additional information.

HORSEPOWER REQUIREMENTS

FLOW		PRESSURE				MOTOR PULLEY SIZE	
		PSI 3000	PSI 3500	PSI 4000	PSI 5000	Using 1725 RPM Motor & Std. Pump Pulley O.D.	
U.S. GPM	L/M	BAR 210	BAR 245	BAR 275	BAR 345	RPM	Pulley O.D.
4.5	17	9.3	10.8	12.3	15.4	1700	9.5
4.0	15	8.2	9.6	11.0	13.7	1511	8.5

DETERMINING THE PUMP R.P.M.	<u>Rated G.P.M.</u> Rated R.P.M.	=	<u>"Desired" G.P.M.</u> "Desired" R.P.M.
DETERMINING THE REQUIRED H.P.	<u>GPM x PSI</u> 1460	=	Electric Brake H. P. Required
DETERMINING MOTOR PULLEY SIZE	<u>Motor Pulley O.D.</u> Pump R.P.M.	=	<u>Pump Pulley O.D.</u> Motor R.P.M.

See complete Drive Packages [Incls: Pulleys, Belts, Hubs, Key] Tech Bulletin 003.
Refer to pump Service Manual for repair procedure and additional technical information.

"Customer confidence is our greatest asset"

PARTS LIST

ITEM	PART NUMBER				DESCRIPTION	QTY
	781	MATL	781K	MATL		
● 2	30067	STL	30067	STL	Key (M8x7.5x25)	1 ●
5	89618	S	89618	S	Screw, HH (M6x16)	8
6	15849	S	15849	S	Lockwasher (M6)	8
7	19933	S	19933	S	Washer (M6)	8
8	43466	AL	43466	AL	Cover, Bearing	1
9	43261	FBR	43261	FBR	Shim, Adjusting, Bearing, 2 Pc.	1/2
10	12393	NBR	12393	NBR	O-Ring, Bearing Cover	2
11	43222	NBR	43222	NBR	Seal, Oil, Crankshaft	1
15	43221	STL	43221	STL	Bearing, Roller	2
20	46555	HS	46555	HS	Rod, Connecting	3
25	119234	FCM	119234	FCM	Crankshaft, Single End (60mm Extension)	1
	46554	FCM	46554	FCM	Crankshaft, Single End (34mm Extension) Gearbox Only	1
30	44967	AL	44967	AL	Cover, Bearing Blind	1
31	828710	—	828710	—	Protector, Oil Cap	1
32	44666	RTP	44666	RTP	Cap, Oil Filler, Domed	1
33	14177	NBR	14177	NBR	O-Ring, Oil Filler Cap - 70D	1
37	92241	—	92241	—	Gauge, Bubble, Oil w/Gasket - 80D	1
38	44428	NBR	44428	NBR	Gasket, Flat Flex., Oil Gauge - 80D	1
40	89618	S	89618	S	Screw, HH (M6x16)	4
41	15849	S	15849	S	Lockwasher (M6)	4
42	19933	S	19933	S	Washer (M6)	4
48	25625	STCP	25625	STCP	Plug, Drain (1/4"x19BSP)	1
49	23170	NBR	23170	NBR	O-Ring, Drain Plug - 70D	1
50	46509	AL	46509	AL	Cover, Rear	1
51	44836	NBR	44836	NBR	O-Ring, Rear Cover - 70D	1
● 53	45361	AL	45361	AL	Crankcase (M10)	1 ●
64	43237	CM	43237	CM	Pin, Crosshead	3
65	48913	HS	48913	HS	Rod, Plunger, Short	3
69	43227	STZP	43227	STZP	Washer, Oil Seal	3
70	43228	NBR	43228	NBR	Seal, Oil, Crankcase	3
75	43328	S	43328	S	Slinger, Barrier	3
88	45697	S	45697	S	Washer, Keyhole (M18)	3
90	45890	CC	45890	CC	Plunger (M14x72)	3
95	89653	SS	89653	SS	Stud, Plunger Retainer (M6x58)	3
96	43235	PTFE	43235	PTFE	Back-up-Ring, Plunger Retainer	3
97	17399	NBR	17399	NBR	O-Ring, Plunger Retainer - 80D	3
	14160	FPM	14160	FPM	O-Ring, Plunger Retainer - 80D	3
98	44041	SS	44041	SS	Gasket, Plunger Retainer	3
99	44031	SS	44031	SS	Retainer, Plunger (M6)	3
100	45686	PVDF	45686	PVDF	Retainer, Seal	3
104	701734	NBR	701734	NBR	O-Ring, Inlet Adapter - 70D	3
	701912	FPM	701912	FPM	O-Ring, Inlet Adapter - 75D	3
105	701587	SS	701587	SS	Adapter, Inlet	3
106	48821	NBR	48821	NBR	Seal, LPS w/SS-Spg	3
	701790	SFTA*	701790	SFTA*	Seal, LPS w/SS-Spg	3
● 110	701593	SSL	—	—	Manifold, Inlet/Discharge, Block-Style	1 ●
●	—	—	701917	SSL	Manifold, Inlet/Discharge, Block-Style, Flushed	1 ●
112	701595	NBR	701595	NBR	O-Ring, V.P. Spacer - 70D	3
	701913	FPM	701913	FPM	O-Ring, V.P. Spacer - 75D	3
117	87952	S	87952	S	Screw, HSH (M10x55)	4
118	701740	SS	701740	SS	Plug (M8x10)	3/0
122	701598	PTFE	701598	PTFE	Back-up-Ring, V.P. Cylinder	3
123	701596	NBR	701596	NBR	O-Ring, V.P. Cylinder - 70D	3
	701914	FPM	701914	FPM	O-Ring, V.P. Cylinder - 75D	3
124	701589	SS	701589	SS	Cylinder, V.P.	3
126	701682	SS	701682	SS	Adapter, Female	3
127	45895	SNG	45895	SNG	V-Packing	9
	701911	SFTA*	701911	SFTA*	V-Packing	9
128	701683	SS	701683	SS	Adapter, Male	3
139	45156	SS	45156	SS	Plug, Inlet/Discharge Manifold (1/2" NPT)	1
162	701599	PTFE	701599	PTFE	Back-up-Ring, Valve Seat	12
163	701597	NBR	701597	NBR	O-Ring, Seat - 70D	12
	701915	FPM	701915	FPM	O-Ring, Seat - 75D	12
164	701591	SSL	701591	SSL	Seat	6
166	701751	SSL	701751	SSL	Valve	6
167	44056	SS	44056	SS	Spring	6
168	44565	PVDF	44565	PVDF	Retainer, Spring	6
170	701737	SS	701737	SS	Washer, Retainer	6
● 185	701594	SSL	701594	SSL	Manifold, Valve, Block-Style	1 ●
188	87952	S	87952	S	Screw, HSH (M10x55)	14
255	30243	STZP	30243	STZP	Kit, Direct Mount	1
260	30645	STZP	30645	STZP	Assy, Angle Rail A, U.S. (30635,30900,30910,30920)	1
	30611	STZP	30611	STZP	Assy, Angle Rail B, U.S. (28499,30900,30910,30920)	1
265	30660	—	30660	—	Kit, Complete Mounting, U.S. (30645,33000,30206,43256,30067)	1
● 269	—	—	—	—	Pulley [See Drive Package Tech 003]	1 ●

EXPLODED VIEW

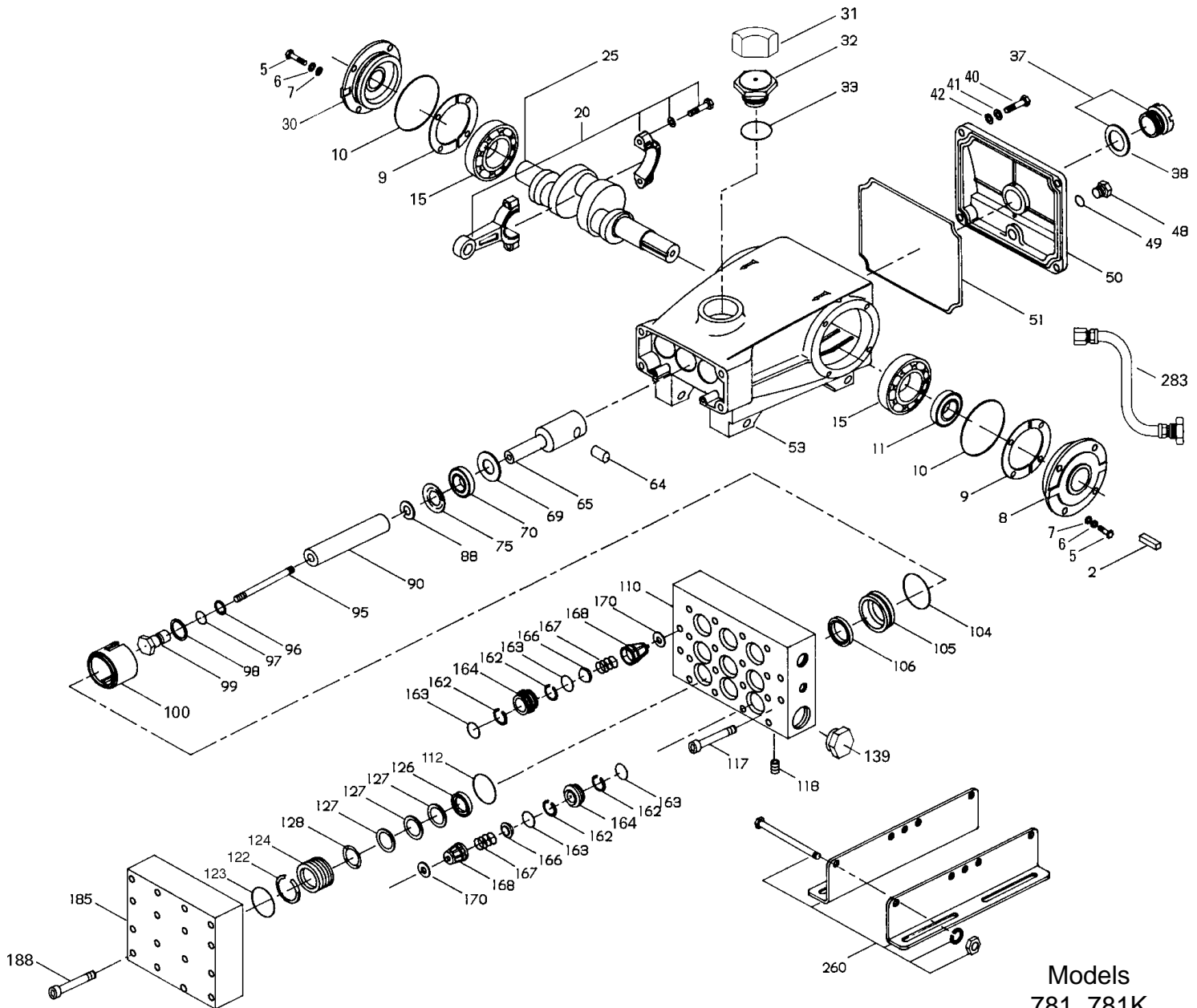

Models
781, 781K
June 2002

	781	MATL	781K	MATL		
● 274	33000	STL	33000	STL	Hub "H" (M24) (Keyway M8) [See Drive Package Tech 003]	1 ●
● 283	34334		34334		Kit, Oil Drain	1 ●
● 299	910102	SSL	—	—	Head, Complete, Block-Style	1 ●
●	—	—	910103	SSL	Head, Complete, Block-Style, Flushed	1 ●
300	701883	NBR	701883	NBR	Kit, Seal (Incls: 96,97,104,106,112,122,123,127)	1
	701920	FPM*	701920	FPM*	Kit, Seal (Incls: 96,97,104,106,112,122,123,127)	1
310	701884	NBR	701884	NBR	Kit, Valve (Incls: 162,163,164,166,167,168)	2
	701921	FPM	701921	FPM	Kit, Valve (Incls: 162,163,164,166,167,168)	2
350	30696	STZP	30696	STZP	Plier, Reverse	1
352	44050	STZP	44050	STZP	Gauge, Oil, Removal Tool	1
● 370	—	—	990663	—	Assembly, Flushing, 5 gal, 1 GPM, 3 PSI	1 ●
● —	711500	SS	711500	SS	C.A.T. (For R.O. or Industrial Applications)	1 ●
● —	711502	SS	711502	SS	Adapter (2 per C.A.T.) (See Data Sheet for complete selection)	2 ●
—	6107		6107		Oil, Bottle (21 oz.) ISO 68 Multi-viscosity Hydraulic (Fill to specified crankcase capacity prior to start-up)	1

● Industrial discount. **Bold print part numbers are unique to a particular pump model.** *Italics are optional items.* [] Date of latest production change.

*Review material codes for individual items (SFTA generally may be used as alternate).

See Tech Bulletins 002, 003, 024, 035, 036, 043, 053, 054, 061, 064, 067, 074, 077 and 083 for additional information.

See 8051-8078 Gearbox data sheet for optional gearbox drive.

MATERIAL CODES (Not Part of Part Number): AL=Aluminum CC=Ceramic CM=Chrome-moly FBR=Fiber FCM=Forged Chrome-moly

FPM=Fluorocarbon (Viton®) HS=High Strength NBR=Medium Nitrile (Buna-N) PTFE=Pure Teflon® PVDF=Fluoroplastic (High Strength) RTP=Reinforced Composite
S=304SS SFTA=Special Blend (Teflon®) Tan SNG=Special Blend (Buna) SS=316SS SSL=316SS/Low Carbon STCP=Steel/Chrome Plated STL=Steel STZP=Steel/Zinc Plated

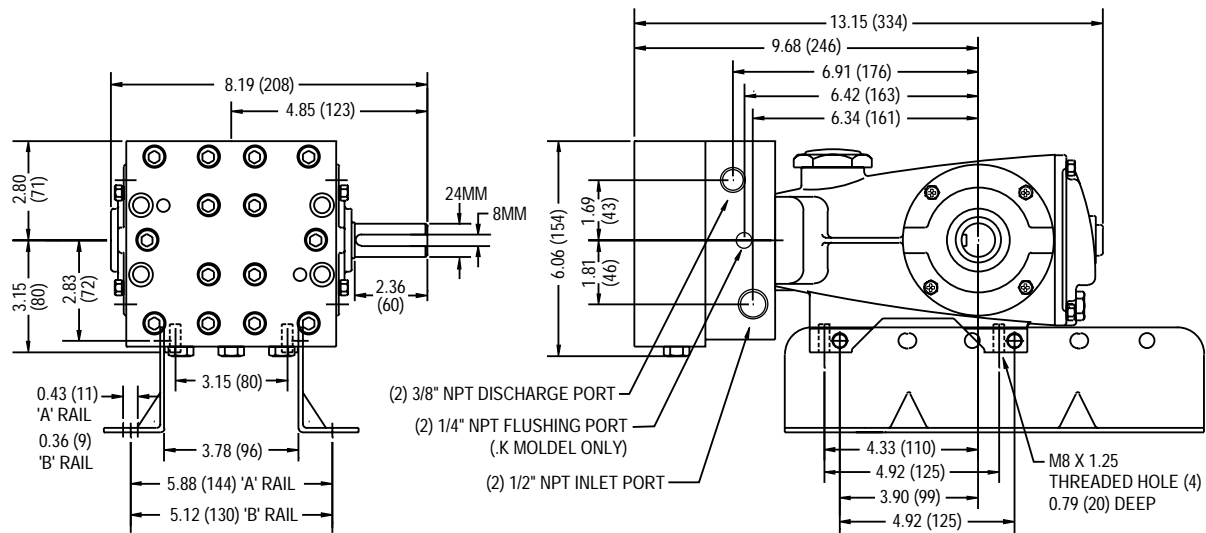

Models 781, 781K

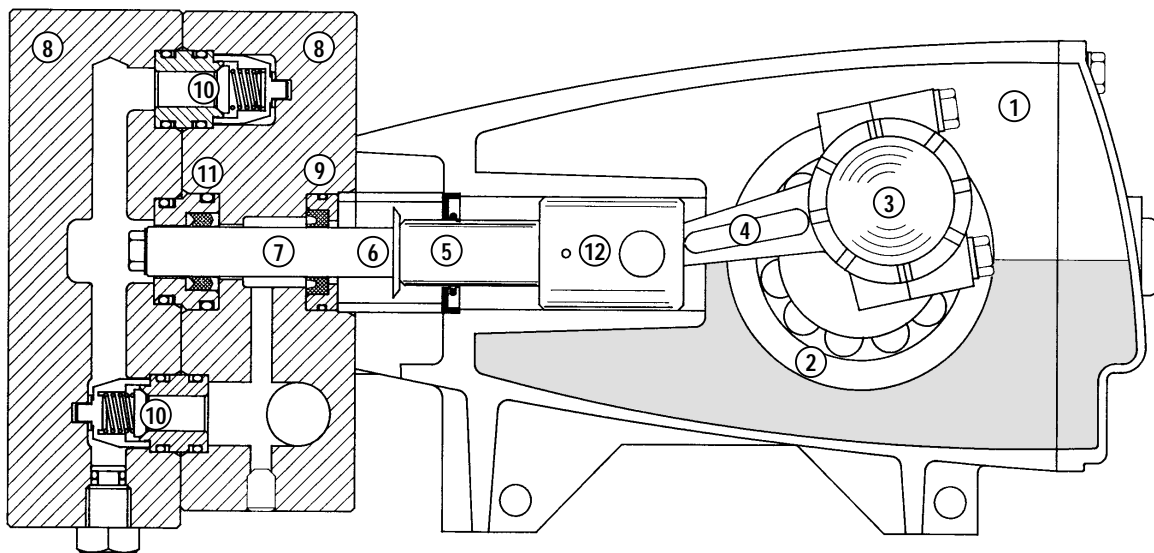

- | | | |
|--|---|--|
| <p>1 Die cast aluminum crankcase means high strength, lightweight, and excellent tolerance control.</p> <p>2 Oversized crankshaft bearings provide extended bearing life and pump performance.</p> <p>3 Chrome-moly crankshaft provides unmatched strength and surface hardness for long life.</p> <p>4 Matched oversized high strength connecting rods are noted for superior strength and bearing quality.</p> <p>5 Special stainless steel plunger rods with high strength crossheads for longevity and corrosion resistance.</p> | <p>6 The stainless steel slinger provides back-up protection for the crankcase seal, keeping pumped liquids out of the crankcase.</p> <p>7 Special concentric, high density, polished, graphite impregnated, solid ceramic plungers are abrasion resistant and result in extended seal life.</p> <p>8 Manifolds are 316 SSL block-style for long-term continuous duty and corrosion resistance.</p> <p>9 Standard Models: Lo-Pressure Seals and V-Packings are completely lubricated and cooled by the liquid being pumped.</p> | <p>9 Flushed Models: Special ported inlet manifold permits liquid to cool or flush between V-Packings and Lo-Pressure Seals providing protection against high temperatures or contaminating pumped liquids.</p> <p>10 316 SSL valves and seats provide corrosion-resistance, positive seating and long life.</p> <p>11 Specially formulated, CAT PUMP exclusive, V-Packings offer unmatched performance and seal life.</p> <p>12 Crossheads are 360° supported providing uncompromising alignment.</p> |
|--|---|--|

Products described hereon are covered by one or more of the following U.S. patents 3558244, 3652188, 3809508, 3920356, 3930756 and 5035580

World Headquarters

CAT PUMPS

1681 - 94th Lane N.E. Minneapolis, MN 55449-4324

Phone (763) 780-5440 — FAX (763) 780-2958

e-mail: sales@catpumps.com

www.catpumps.com

International Inquiries

FAX (763) 785-4329

e-mail: intl@catpumps.com



The Pumps with Nine Lives

CAT PUMPS (U.K.) LTD.

1 Fleet Business Park, Sandy Lane, Church Crookham, Fleet

Hampshire GU52 8BF, England

Phone Fleet 44 1252-622031 — Fax 44 1252-626655

e-mail: sales@catpumps.co.uk

N.V. CAT PUMPS INTERNATIONAL S.A.

Heiveldekens 6A, 2550 Kontich, Belgium

Phone 32-3-450.71.50 — Fax 32-3-450.71.51

e-mail: cpi@catpumps.be www.catpumps.be

CAT PUMPS DEUTSCHLAND GmbH

Buchwiese 2, D-65510 Idstein, Germany

Phone 49 6126-9303 0 — Fax 49 6126-9303 33

e-mail: catpumps@t-online.de www.catpumps.de