



10 Frame Piston Pump

Models

623
820
1010

FEATURES

Superior Design

- Triplex Uniflow design provides continuous forward liquid flow for smooth operation.
- Wetted cups and floating pistons are lubricated and cooled by pumped liquid for long cup life.
- Mechanically actuated inlet valves give strong lift and easy prime.
- Oil bath crankcase assures optimum lubrication.

Quality Materials

- Cylinder and sleeve wear surfaces are hard chrome plated 304 stainless steel for maximum durability and abrasion resistance.
- Chrome plated, brass manifolds and optional stainless steel manifolds are strong and corrosion resistant.
- Heavy duty connecting rods are made of high quality Zamak offering superior bearing quality strength.
- Chrome-moly crankshaft gives unmatched strength and surface hardness.
- Oversized crankshaft bearings with greater loading capacity mean longer bearing life.

Easy Maintenance

- Stepped stainless steel piston rod with chrome plated, stainless steel sleeve allows easy replacement from front of pump.
- All wet-end wear parts are easily serviced without entering crankcase, requiring less time and effort.
- Wear parts are available in convenient kits.
- Routine lubrication checks are the only maintenance required on this precision built pump.

$$\frac{\text{DETERMINING THE PUMP R.P.M.}}{\text{Rated G.P.M.}} = \frac{\text{“Desired” G.P.M.}}{\text{Rated R.P.M.}}$$

$$\frac{\text{DETERMINING THE REQUIRED H.P.}}{\text{GPM} \times \text{PSI}} = \frac{\text{Electric Brake H. P. Required}}{1460}$$

$$\frac{\text{DETERMINING MOTOR PULLEY SIZE}}{\text{Motor Pulley O.D.}} = \frac{\text{Pump Pulley O.D.}}{\text{Motor R.P.M.}}$$

Note: Consult engine manufacturer when using gas or diesel engine. Refer to pump Service Manual for important Inlet Condition Check-List, Start-up Procedure, Tech Bulletins and Pump Maintenance information.

SPECIFICATIONS

MODEL 623

	U.S. Measure	Metric Measure
Flow	6.0 GPM	(23 L/M)
Pressure Range	100 to 1200 PSI	(7 to 85 BAR)
RPM	850 RPM	(850 RPM)
Bore	0.787"	(20 mm)
Stroke	1.122"	(28.5 mm)

MODEL 820

Flow	10 GPM	(38 L/M)
Pressure Range	100 to 1000 PSI	(7 to 70 BAR)
RPM	940 RPM	(940 RPM)
Bore	0.984"	(25 mm)
Stroke	1.102"	(28 mm)

MODEL 1010

Flow	13 GPM	(49 L/M)
Pressure Range	100 to 700 PSI	(7 to 50 BAR)
RPM	900 RPM	(900 RPM)
Bore	1.122"	(28.5 mm)
Stroke	1.102"	(28 mm)

COMMON SPECIFICATIONS

Crankcase Capacity	40 oz.	(1.2 L)
Maximum Liquid Temperature	160°F	(71°C)
Inlet Pressure Range	-8.5 to +40 PSI	(-0.6 to +2.8 BAR)
Inlet Ports (1)	1" NPTF	(1" NPTF)
Discharge Ports (3)	3/4" NPTF	(3/4" NPTF)
Shaft Diameter	0.984"	(25 mm)
Weight	34.6 lbs.	(15.7 kg)
Dimensions	16.65 x 11.42 x 6.25"	(423 x 290 x 159 mm)

HORSEPOWER REQUIREMENTS

MODEL	FLOW		PRESSURE				MOTOR PULLEY SIZE	
	U.S. GPM	L/M	PSI 500	PSI 700	PSI 1000	PSI 1200	Using 1725 RPM Motor & Std. 10.0" Pulley	
			BAR 35	BAR 50	BAR 70	BAR 85	RPM	Motor Pulley O.D.
623	6.0	23	2.1	2.9	4.1	4.9	850	4.7
	5.0	19	1.7	2.4	3.4	4.1	709	4.0
	4.0	15	1.4	1.8	2.8	3.3	567	3.1
820	10.0	38	3.4	4.8	6.9	NA	940	5.3
	9.0	34	3.1	4.3	6.2	NA	846	4.8
	8.0	30	2.8	3.8	5.5	NA	752	4.3
1010	13.0	49	4.5	6.2	NA	NA	900	5.0
	10.0	38	3.4	4.8	NA	NA	750	4.3
	8.0	30	2.8	3.8	NA	NA	600	3.4

See complete Drive Packages [Incls: Pulleys, Belts, Hubs, Key] Tech Bulletin 03.

“Customer confidence is our greatest asset”

PARTS LIST

ITEM	PART NUMBER		DESCRIPTION		QTY			
	623	MATL	820	MATL	1010	MATL		
● 2	50146	STL	50146	STL	50146	STL	Key (M7x7x40)	1 ●
5	92519	STZP	92519	STZP	92519	STZP	Screw, HHC Sems (M6x16)	8
8	27331	AL	27331	AL	27331	AL	Cover, Bearing	2
10	26965	NBR	26965	NBR	26965	NBR	O-Ring, Bearing Cover - 70D	2
11	27330	NBR	27330	NBR	27330	NBR	Seal, Oil, Crankshaft	2
15	47080	STL	47080	STL	47080	STL	Bearing, Ball	2
20	27334	ZZ	27334	ZZ	27334	ZZ	Rod, Connecting, Assy	3
25	27329	FCM	27329	FCM	27329	FCM	Crankshaft, Dual End	1
31	828710		828710		828710		Protector, Oil Cap	1
32	43211	ABS	43211	ABS	43211	ABS	Cap, Oil Filler	1
33	14177	NBR	14177	NBR	14177	NBR	O-Ring, Oil Filler Cap - 70D	1
37	92241		92241		92241		Gauge, Oil Bubble w/Gasket - 80D	1
38	44428	NBR	44428	NBR	44428	NBR	Gasket, Flat, Oil Gauge - 80D	1
40	92520	STZP	92520	STZP	92520	STZP	Screw, HHC Sems (M6x20)	4
48	25625	STCP	25625	STCP	25625	STCP	Plug, Drain (1/4"x19BSP)	1
49	23170	NBR	23170	NBR	23170	NBR	O-Ring, Drain Plug - 70D	1
50	43491	AL	43491	AL	43491	AL	Cover, Rear	1
51	44834	NBR	44834	NBR	44834	NBR	O-Ring, Cover - 70D	1
● 53	44641	AL	44641	AL	44641	AL	Crankcase w/Guide Pins	1 ●
55	14050	STZP	14050	STZP	14050	STZP	Stud (M10x45)	4
56	27911	POP	27911	POP	27911	POP	Pan, Oil (use with items 100,101,106)	1
64	20251	CM	20251	CM	20251	CM	Pin, Crosshead	3
65	27337	SZZ	27337	SZZ	27337	SZZ	Rod, Piston	3
69	26952	STZP	26952	STZP	26952	STZP	Washer, Oil Seal	3
70	27339	NBR	27339	NBR	27339	NBR	Seal, Oil, Crankcase	3
75	25327	S	25327	S	25327	S	Slinger, Barrier	3
77	25392	NBR	25392	NBR	25392	NBR	O-Ring, Sleeve	6
	28771	FPM	28771	FPM	28771	FPM	O-Ring, Sleeve	6
80	27340	SCP	27340	SCP	27340	SCP	Sleeve	3
	28782	S	28782	S	28782	S	Sleeve	3
81	29003	PTFE	29003	PTFE	29003	PTFE	Back-up-Ring, Sleeve	3
100	27341	PVDF	27341	PVDF	27341	PVDF	Retainer, Seal	3
101	27910		27910		27910		Wick-Long Tab (use with items 56,100,106)	3
106	30315	NBR	30315	NBR	30315	NBR	Seal, LPS, Prrrrm-A-Lube (greased)	3
	30325	FPM	30325	FPM	30325	FPM	Seal, LPS, Prrrrm-A-Lube (greased)	3
	25153	NBR	25153	NBR	25153	NBR	Seal, Blue-Dot (ungreased) (use with items 56,100,101)	3
	100015	FPM	100015	FPM	100015	FPM	Seal, Blue-Dot (ungreased) (use with items 56,100,101)	3
110	27344	BBCP	27344	BBCP	27344	BBCP	Manifold, Inlet	1
● 119	30247	SS	30247	SS	30247	SS	Manifold, Inlet	1 ●
	27347	S	27497	S	27813	S	Valve, Inlet	3
130	30543	S	27820	S	27814	S	Piston	3
131	30544	PTFE	—	—	—	—	Ring, Bac-Cup	3
133	43172	FPM	27821	FPM	27815	FPM	Cup, Piston	3
133	43474	FPM	—	—	—	—	Bac-Cup Assy (43172,30543,30544)	3
133	30340	NBR	—	—	—	—	Cup, Piston, Machined	3
133	29089	NBR	29091	NBR	29092	NBR	Cup, V-Hot (1000 PSI Max.)	3
133	30145	TG	30333	TG	30189	TG	Piston-Cup Assy (1000 PSI Max.)	3
135	27348	S	27499	S	27499	S	Spacer, Piston	3
136	27002	S	27500	S	20324	S	Retainer, Piston	3
137	27006	S	27006	S	27006	S	Washer, Conical	3
138	27000	S	27000	S	27000	S	Nut, Slotted (M6)	3
139	14158	S	14158	S	14158	S	Cotterpin (M1.6x10)	3
143	26969	NBR	26969	NBR	26969	NBR	O-Ring, Cylinder - 70D	6
	28459	FPM	28459	FPM	28459	FPM	O-Ring, Cylinder	6
150	28342	SCP	28340	SCP	28341	SCP	Cylinder (M50)	3
	28776	S	28778	S	28780	S	Cylinder (M50)	3
153	28204	PTFE	28204	PTFE	—	—	Back-up-Ring, Cylinder	3
162	43062	PTFE	43062	PTFE	43062	PTFE	Back-up-Ring, Seat	3
163	26966	NBR	26966	NBR	26966	NBR	O-Ring, Seat - 70D	3
	28458	FPM	28458	FPM	28458	FPM	O-Ring, Seat - 70D	3
164	43428	S	43428	S	43428	S	Seat, Q.V.	3
	43063	S	43063	S	43063	S	Seat, F.V.	3
166	43721	S	43721	S	43721	S	Valve, Q.V.	3
	20262	S	20262	S	20262	S	Valve, F.V.	3
167	43251	S	43251	S	43251	S	Spring, Q.V.	3
	20265	S	20265	S	20265	S	Spring, F.V.	3
168	43429	S	43429	S	43429	S	Retainer, Spring, Q.V.	3
	43135	S	43135	S	43135	S	Retainer, Spring, F.V.	3
185	43046	BBCP	43046	BBCP	43046	BBCP	Manifold, Discharge	1
● 186	30248	SS	30248	SS	30248	SS	Manifold, Discharge	1 ●
	6410	BB	6410	BB	6410	BB	Manifold, Pulse Pump (1000 PSI Max.) (625,825,1015)	1
187	43641	STZP	43641	STZP	43641	STZP	Washer, Connecting Rod (M10.5x1.5)	4/8
188	43047	STCP	43047	STCP	43047	STCP	Stud, Hex, Manifold "B"	4
189	43641	STZP	43641	STZP	43641	STZP	Washer, Connecting Rod (M10.5x1.5)	4/8
190	26950	STZP	26950	STZP	26950	STZP	Washer (M10x0.5)	4/8
191	26951	STL	26951	STL	26951	STL	Washer (M10x0.3)	4/8
192	27357	STZP	27357	STZP	27357	STZP	Lockwasher (M10)	4
194	12503	STZP	12503	STZP	12503	STZP	Lockwasher (M10)	4
196	81048	STZP	81048	STZP	81048	STZP	Nut, Hex (M10x1.5)	4
250	20326	BBCP	20326	BBCP	20326	BBCP	Plug, Discharge Manifold (3/4" NPT)	1
255	43139	STCP	43139	STCP	43139	STCP	Protector, Shaft	1
260	30264	STZP	30264	STZP	30264	STZP	Kit, Direct Mount	1
265	30613	STZP	30613	STZP	30613	STZP	Angle, Rail Assy, A. U.S. (Incls: 30635, 30921,30912,30903)	1
● 270	30653	F	30653	F	30653	F	Kit, Mounting (Incls: 30613,30206,30284,43139)	1 ●
● 274	30234	STL	30234	STL	30234	STL	Pulley (10") [See Drive Packages, Tech Bulletin 03]	1 ●
● 275	30284	STL	30284	STL	30284	STL	Hub, "H" M25 (Keyway M7) [See Drive Packages, Tech Bulletin 03]	1 ●
							Hub & Key Assy [See Drive Packages, Tech Bulletin 03]	1 ●

EXPLODED VIEW

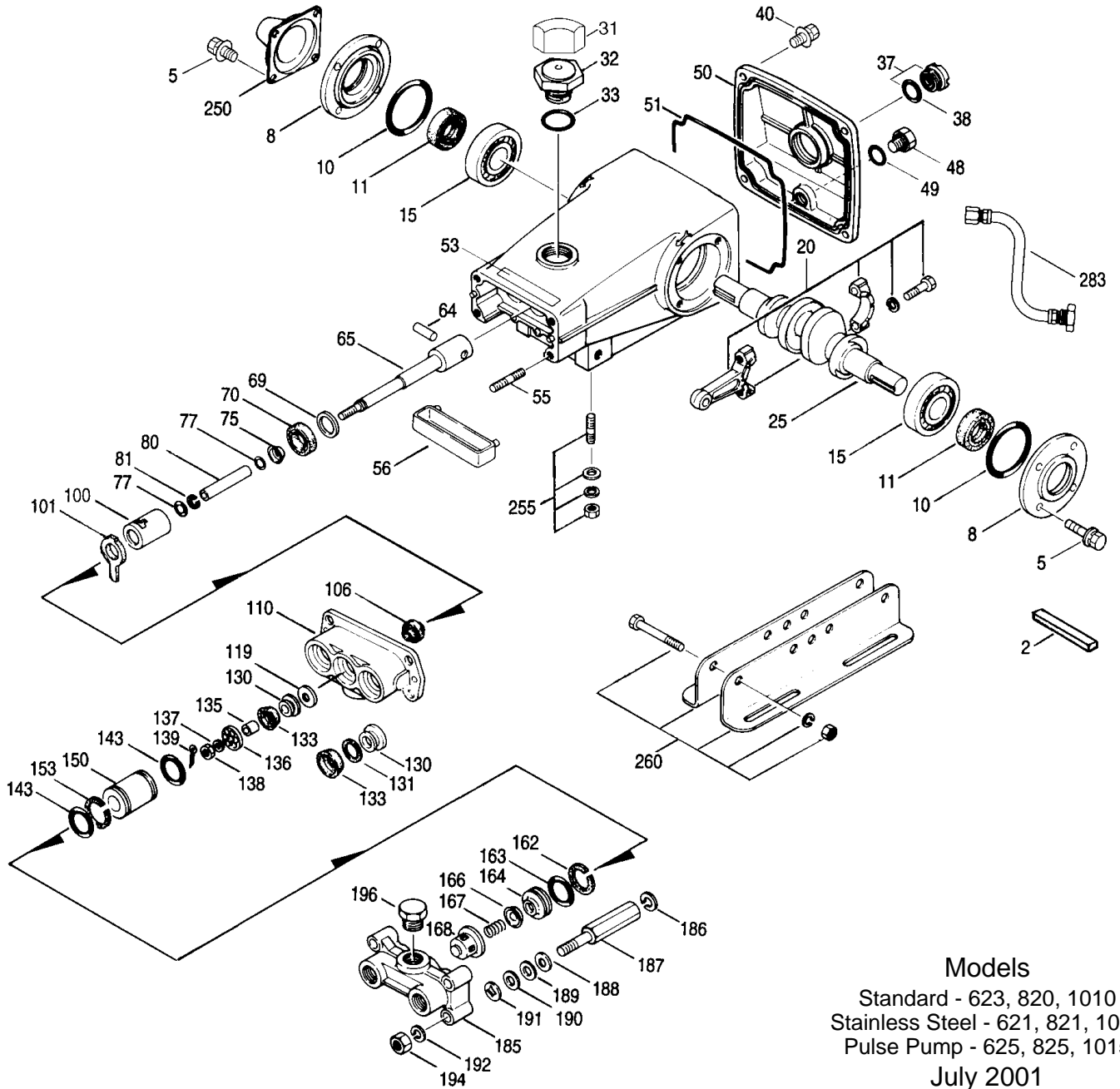

Models
 Standard - 623, 820, 1010
 Stainless Steel - 621, 821, 1011
 Pulse Pump - 625, 825, 1015
 July 2001

	623	MATL	820	MATL	1010	MATL		
● 283	34334		34334		34334		Kit, Oil Drain	1
295	6300	BBSS	6300	BBSS	6300	BBSS	Pump, Pulse (1 Qt.) 1000 PSI (See individual data sheet)	1
	6305	BBSS	6305	BBSS	6305	BBSS	Pump, Pulse (1 Gal.) 1000 PSI (See individual data sheet)	1
300	30220	NBR	30222	NBR	30224	NBR	Kit, Cup (Incls: 133,139,143,153,355 for 820 & 1010)	1
301	30822	NBR	—	—	—	—	Kit, Bac-Cup (Incls: 133,139,143,355)	1
302	30219	NBR	30221	NBR	30223	NBR	Kit, Piston (Incls: 119,130,133,135-139,143,153,355)	1
	30843	NBR	—	—	—	—	Kit, Bac-Cup Piston (Incls: 119,133,139,143,153,355)	1
305	30397	NBR	30397	NBR	30397	NBR	Kit, Sleeve and Prrrrm-A-Lube Seal (Incls: 75,77,80,106,139)	1
	30227	NBR	30227	NBR	30227	NBR	Kit, Sleeve and Blue-Dot Seal (Incls: 77,80,101,106,139)	1
306	30305	NBR	30305	NBR	30305	NBR	Kit, Prrrrm-A-Lube Seal (Incls: 106,139)	1
	30226	NBR	30226	NBR	30226	NBR	Kit, Blue-Dot Seal (Incls: 101,106,139)	1
310	30687	NBR	30687	NBR	30687	NBR	Kit, Valve, Q.V. (Incls: 143,153,162-168)	1
	30449	NBR	30449	NBR	30449	NBR	Kit, Valve, F.V. (Incls: 143,153,162-168)	1
355	22130	NY	16981	NY	15770	NY	Insert, Cup	1
352	44050	STZP	44050	STZP	44050	STZP	Tool, Oil Gauge Removal	1
360	25082	STZP	25082	STZP	25082	STZP	T-Wrench (M10)	1
	25083	STZP	25083	STZP	25083	STZP	T-Wrench (M17)	1

● Industrial discount. **Bold print part numbers are unique to a particular pump model.** *Italics are optional items.*

See Tech Bulletins 01, 02, 03, 05, 16, 17, 20, 24, 26, 34, 36, 37, 38, 42, 74, 77 and 83 for additional information.

MATERIAL CODES (Not Part of Part Number): ABS=ABS Plastic AL=Aluminum BB=Brass BBCP=Brass/Chrome Plated CM=Chrome-Moly F=Cast Iron

FCM=Forged Chrome-moly FPM=Fluorocarbon (Viton®) NBR=Medium Nitrile (Buna-N) NY=Nylon POP=Polypropylene PTFE=Pure Teflon®

PVDF=Fluoroplastic (High Strength) S=304SS SCP=304SS/Chrome Plated SS=316SS STL=Steel STZP=Steel/Zinc Plated

SZZ=304SS/Zamak TG=PTFE Graphite Compound (GIT)

ORDER CODES: When replacing Q.V. with F.V. **add .001** to model number, **add .0110** for FPM (Viton®).

When replacing Prrrrm-A-Lube Seals with Blue-Dot Seals, wick must be installed. **Add .0300** to model number when ordering.

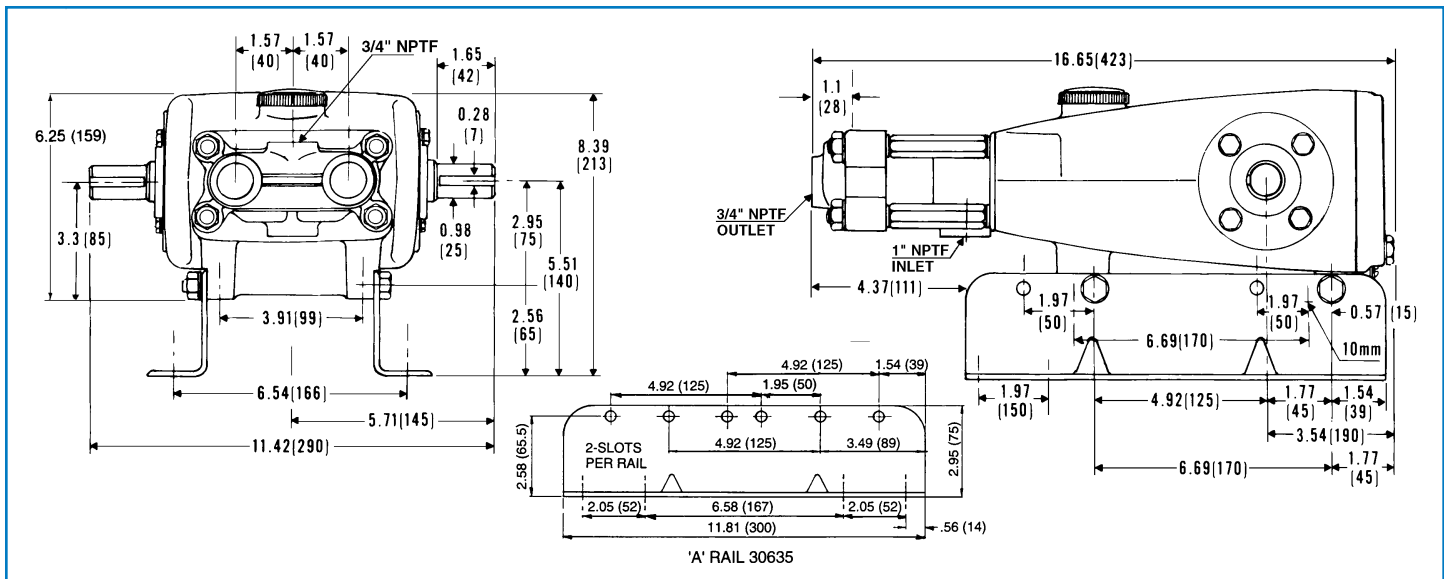

Models 623, 820, 1010

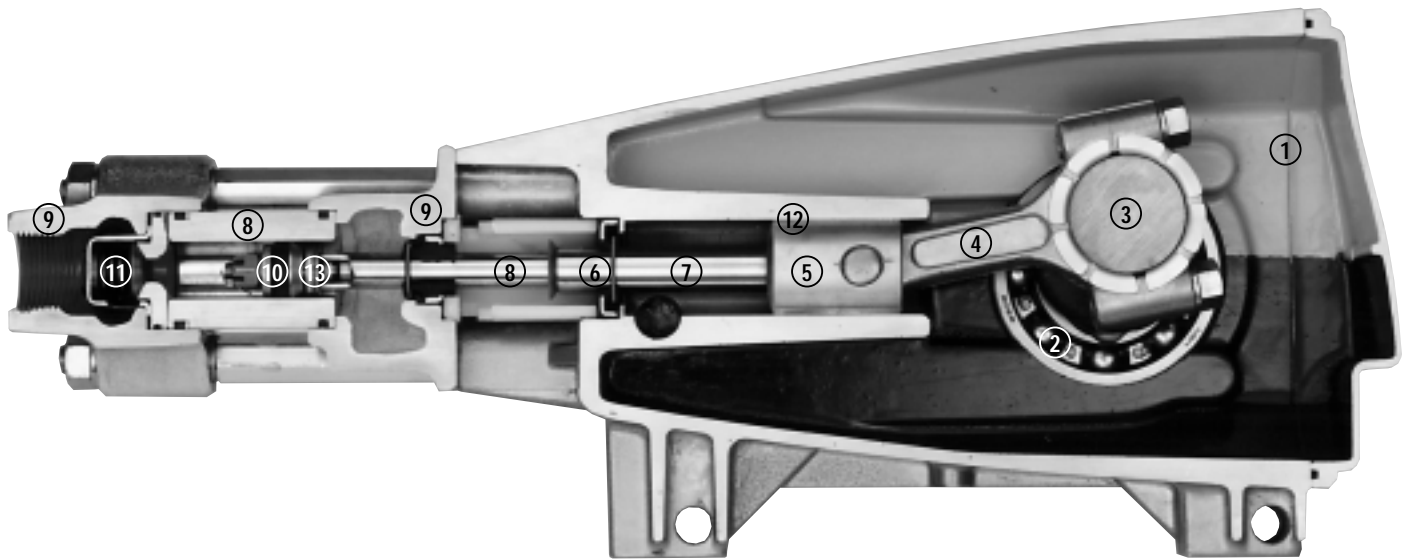

- 1 Die cast aluminum **crankcase** means high strength, lightweight, and excellent tolerance control.
- 2 Oversized crankshaft **bearings** provide extended bearing life and pump performance.
- 3 Chrome-moly **crankshaft** provides unmatched strength and surface hardness for long life.
- 4 Matched oversized **connecting rods** are made of Zamak, a material noted for strength and superior bearing quality.
- 5 The **piston rods** are high tensile strength stainless steel with Zamak crossheads.
- 6 The stainless steel **slinger** provides back-up protection for the crankcase seal, keeping pumped liquids out of the crankcase.
- 7 The **patented stepped piston rod** with hard chrome plated stainless steel **sleeve** provides a durable wear surface and easy wet-end servicing.
- 8 The **cylinder** and **sleeve** wear surfaces are hard chrome plated 304 stainless steel for longer service life.
- 9 **Manifolds** are of high tensile strength chrome plated brass or 316 stainless steel for special corrosion resistance.
- 10 100% wet **cup/seal** design adds to service life by allowing pumped liquids to cool and lubricate the elastomers on both sides.
- 11 304 stainless steel **valves, seats, and springs** provide corrosion-resistance, positive seating and long life.
- 12 **Crossheads** are 360° supported for uncompromising alignment.
- 13 Mechanically actuated **inlet valves** provide strong lift and easy prime.

Products described hereon are covered by one or more of the following U.S. patents 3558244, 3652188, 3809508, 3920356, 3930756 and 5035580

July 2001 61119

World Headquarters
CAT PUMPS
 1681 - 94th Lane N.E. Minneapolis, MN 55449-4324
 Phone (763) 780-5440 — FAX (763) 780-2958
 e-mail: sales@catpumps.com
 www.catpumps.com

International Inquiries
 FAX (763) 785-4329
 e-mail: intlsales@catpumps.com



CAT PUMPS (U.K.) LTD.
 1 Fleet Business Park, Sandy Lane, Church Crookham, Fleet
 Hampshire GU52 8BF, England
 Phone Fleet 44 1252-622031 — Fax 44 1252-626655
 e-mail: sales@catpumps.co.uk

N.V. CAT PUMPS INTERNATIONAL S.A.
 Heiveldekens 6A, 2550 Kontich, Belgium
 Phone 32-3-450.71.50 — Fax 32-3-450.71.51
 e-mail: cpi@catpumps.be www.catpumps.be

CAT PUMPS DEUTSCHLAND GmbH
 Buchwiese 2, D-65510 Idstein, Germany
 Phone 49 6126-9303 0 — Fax 49 6126-9303 33
 e-mail: catpumps@t-online.de www.catpumps.de