



3K Series - Two Stage Stainless Steel End-Suction Centrifugal Pumps

3450 RPM Models

3K502CT2
to 3K532CT4

FEATURES

- 304SSL liquid-end construction offers corrosion resistance and increases operating life over typical cast iron models.
- Unique bulge formed components eliminates harsh radius and welds and provides greater efficiency and durability.
- Back pullout design permits easy repair of impeller and seal.
- High quality mechanical shaft seal and o-rings for chemical duty applications.
- Under casing foot mount and centerline discharge reduces misalignment and assures self-venting.
- Close coupled, motorized packages for compact and easy installation.

SPECIFICATIONS

	U.S. Measure
Flow Range5.5 to 66.0 GPM
Pressure Range42 to 106 PSI
98 to 245 Ft. Head
Max. Working Pressure125 PSI
RPM3450 RPM
Inlet Fitting	3K502CT2, 3K502CT41.25" NPT
	3K512CT4, 3K522CT41.25" NPT
	3K532CT42.00" NPT
Discharge Fitting	All Models.....1" NPT
Horsepower Range2 to 5 HP
Motor Options	IP55 Frame TEFC Class F
	2.0 HP230V, 1 PH
	2.0 HP230/460V, 3 PH
	3.0 HP230/460V, 3 PH
	5.0 HP230/460V, 3 PH
Cycle60 HZ
Max. Temperature	Continuous.....*140°F
WeightSee Chart
DimensionsSee Chart

*Contact CAT PUMPS for applications above 140°F.

“Customer confidence is our greatest asset”

EXPLODED VIEW

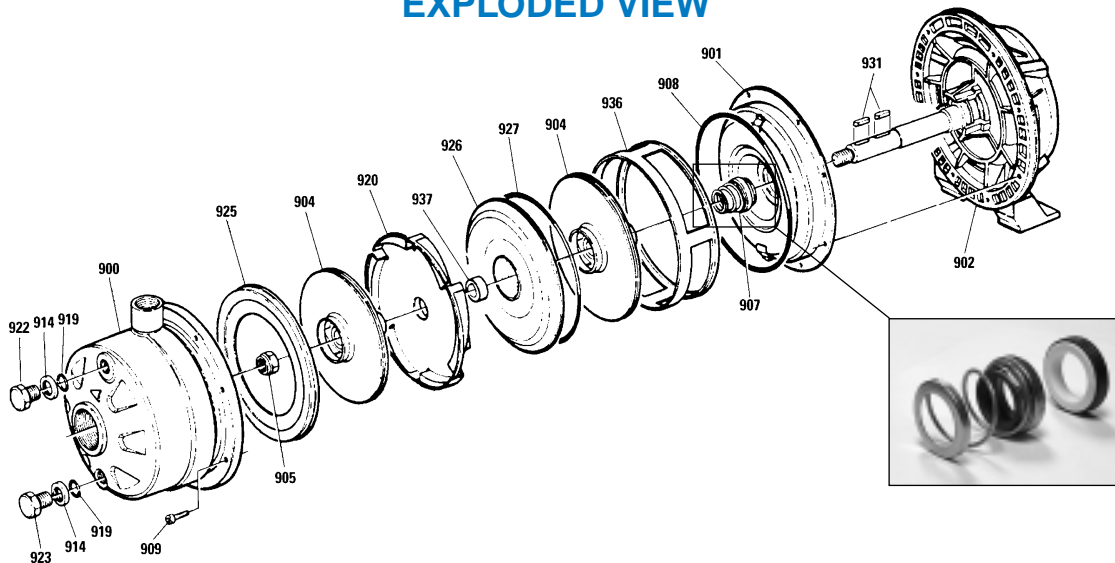

PARTS LIST

ITEM	P/N	MATL	DESCRIPTION	QTY	ITEM	P/N	MATL	DESCRIPTION	QTY
900	—	S	Casing	1	909	—	S	Screw, Socket (M6x16)	8
901	—	S	Cover, Casing	1	914	—	S	Washer, Plug	2
902	—	F	Bracket	1	919	899252	FPM	O-Ring, Plug - 75D	2
904	—	S	Impeller 3K502CT2, 3K502CT4 (5.19")	1	920	—	S	Diffuser	1
	—	S	Impeller 3K502CT2, 3K502CT4, 3K512CT4 (5.19")	1	922	—	S	Plug, Prime, Case	1
	—	S	Impeller 3K512CT4 (6.00")	1	923	—	S	Plug, Drain, Case	1
	—	S	Impeller 3K522CT4 (5.19")	1	925	—	S	Plate, Front	1
	—	S	Impeller 3K532CT4 (6.19")	1	926	—	S	Plate, Center	1
	—	S	Impeller 3K532CT4 (5.19")	1	927	899251	FPM	O-Ring, Center Plate - 75D	1
905	—	S	Impeller, Nut (7/16-20)	1	931	—	S	Key	2
907	899002	FCC	Seal, Shaft Assy (Mild Chemical)	1	936	—	S	Spacer	1
908	899249	FPM	O-Ring, Case - 75D	1	937	—	S	Collar	1

Italics are optional items.

MATERIAL CODES (Not Part of Part Number): F=Cast Iron FCC=Carbon/Ceramic/Viton® FPM=Fluorocarbon (Viton®) S=304SS

DIMENSIONAL

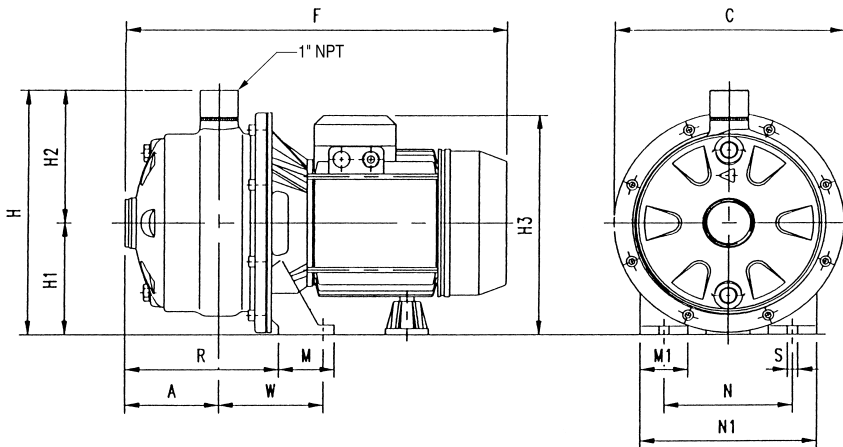

Model	HP	Phase	Pump-Motor Dimensions (in.)													Wt. (lbs.)	
			A	C	F	H	H1	H2	H3	M	M1	N	N1	R	S		W
3K502CT4	2	3	3 7/16	9 1/8	14 15/16	9 13/16	4 7/8	5 3/16	8 7/8	2 3/16	1 7/16	5 1/2	7 1/16	5 1/2	3/8	3 3/4	37
3K512CT4	3	3	3 7/16	9 1/8	14 15/16	9 13/16	4 7/8	5 3/16	8 7/8	2 3/16	1 7/16	5 1/2	7 1/16	5 1/2	3/8	3 3/4	37
3K522CT4	3	3	3 7/16	9 1/8	14 15/16	9 13/16	4 7/8	5 3/16	8 7/8	2 3/16	1 7/16	5 1/2	7 1/16	5 1/2	3/8	3 3/4	39
3K532CT4	5	3	3 7/16	9 1/8	17 3/8	9 13/16	4 7/8	5 3/16	9 1/16	2 11/16	1 13/16	6 5/16	8 1/4	5 11/16	1/2	4 7/16	71
3K502CT2	2	1	3 7/16	9 1/8	15 3/8	9 13/16	4 7/8	4 7/8	9 1/2	2 3/16	1 7/16	5 1/2	7 1/16	5 1/2	3/8	3 3/4	37

PUMP CODES:

Last digit of Pump Kit is Seal Assembly type
 2 = FCC Alternate Seal Assy (Carbon/Ceramic/Viton®) Mild Chemical

MPU CODES:

Last digit of MPU is Motor Phase and Voltage
 Single Phase Three Phase
 0 = 115/208-230V 3 = 208-230/460V
 1 = 115/230V 4 = 230/460V
 2 = 230V 5 = 575V
 6 = 380V

SELECTION CHART - 3450 RPM

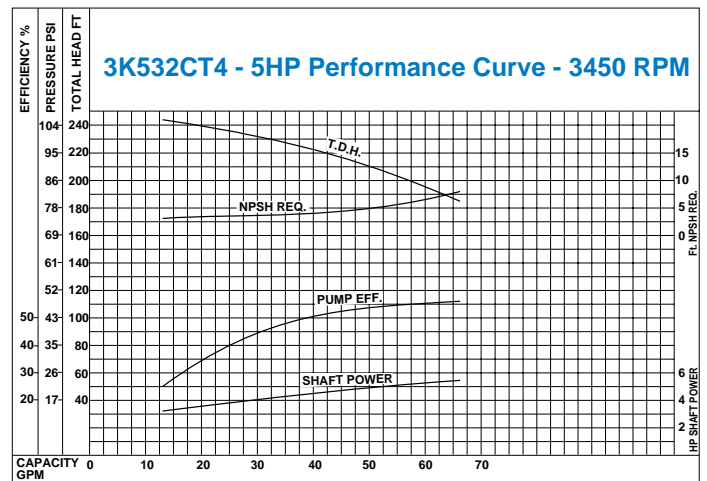
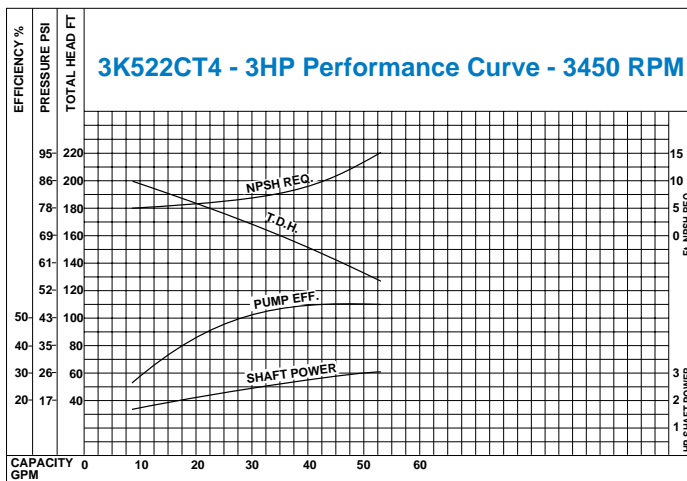
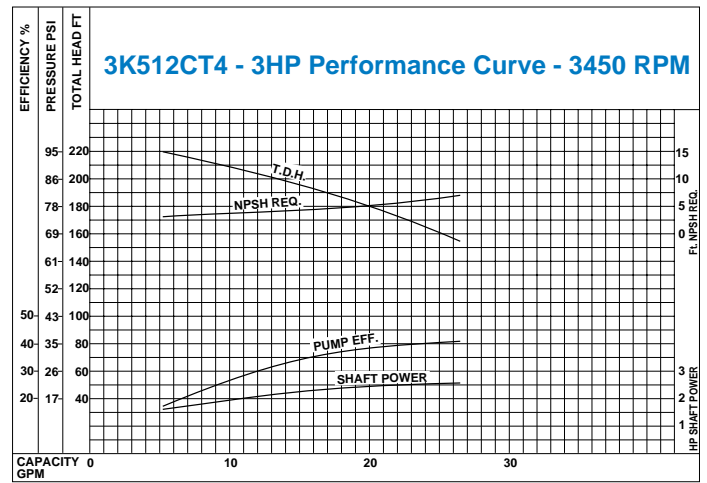
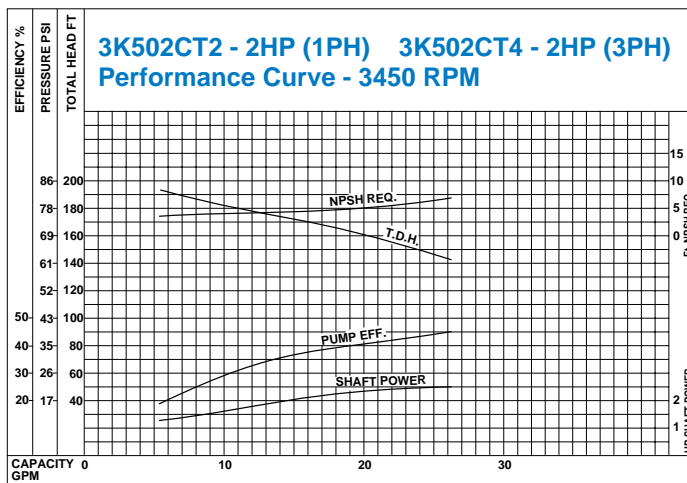
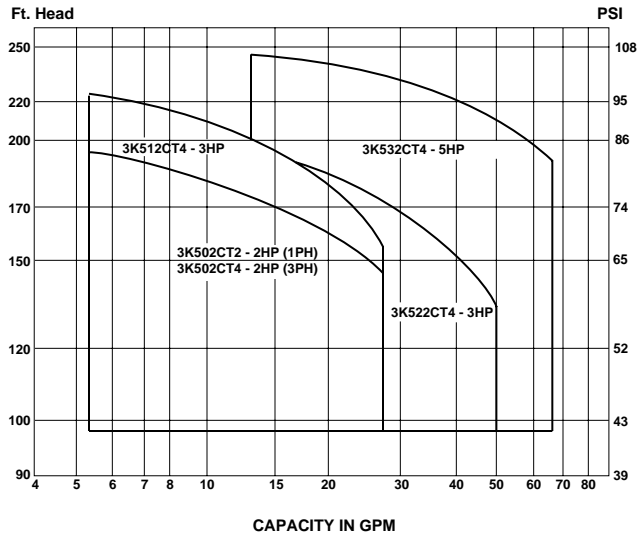

GENERAL SAFETY AND OPERATION

SELECTION: Review the Selection Chart to find the performance range and pump model suited to your application requirements. Then review the Performance Curve Chart to verify the most efficient performance and inlet conditions required.

INSTALLATION: These pumps may be installed in either a horizontal (most common) or vertical position (as installation requires). The following criteria should be considered to assure optimum performance:

- Proper alignment of plumbing
- Adequate line size to prevent starvation
- Rigid metal or plastic pipe or reinforced flexible plumbing to prevent collapsing lines
- Properly sealed connections to prevent air leaks
- Good filtration of the liquid to avoid abrasives and solids
- Foot valve may need to be installed at the inlet

OPERATION: The pump comes with a mild chemical-duty seal for freshwater, non harsh liquids or chemical applications. Check with CAT PUMPS for high viscosity liquids. Make certain there is sufficient liquid supply to the pump inlet before starting operation.

MAINTENANCE: This is a low maintenance pump. The shaft seal and impellers are the primary service items. These can be easily replaced.

Disassembly

1. Remove the eight (8) socket head screws from the casing to bracket.
2. Insert two (2) screwdrivers on opposite sides of the seam between the casing and bracket; pry gently apart.
3. Remove the impeller nut.
4. Remove the first impeller, diffuser, collar, center plate w/o-ring, second impeller, spacer and keys by sliding over the motor shaft.
5. Remove spring and front half of seal (rotating half) from casing cover.

CAUTION

Exercise care when handling the shaft seal. It can be easily contaminated by improper handling and will not properly seal.

6. Pry the casing cover away from the bracket.
7. Place the casing cover on a work surface (large diameter up) and press out the back half (stationary half).
8. Examine all o-rings for cuts or deterioration and replace as needed.

Re-assembly

1. Invert the casing cover on a work surface (small diameter up) and press the back half (stationary half) of the new shaft seal into position until completely seated in the chamber with the elastomer side down.

CAUTION

Exercise care when handling the shaft seal. If can be easily contaminated by improper handling and will not properly seal. Use the paper cover to press the seal into position and toss the cover when done.

NOTE: If seal installation is tight, carefully apply a small amount of lubricant to the outer edge (non-chlorine dish soap). DO NOT USE OIL OR GREASE.

2. Align the casing cover with the holes on the bracket and press into position.
3. Carefully slide the front half of the new seal (rotating half) on the shaft with the carbon and ceramic surfaces mating. Slide spring over the shaft and press onto back side of seal.
4. Install keys on motor shaft.
5. Slide second impeller with small diameter extension towards casing cover. Ensure key way is aligned with key on motor shaft.
6. Slide collar over motor shaft.
7. Position spacer with two notches onto the tabs of casing cover.
8. Install center plate and o-ring with dish side facing outwards.
9. Position diffuser so the small blades are facing the center plate.
10. Slide first impeller with small diameter extension towards diffuser. Ensure key way is aligned with key on motor shaft.
11. Apply Loctite 242 to threads of impeller nut and torque per chart.
NOTE: Rotate the impellers to assure proper alignment before installing front plate and casing.
12. Place casing on work surface with flanged end facing upwards.
13. Place front plate with smaller outer diameter facing upwards.
14. Place casing to desired discharge port position and align holes with bracket. Replace eight (8) socket head screws and torque per chart.

TORQUE CHART

	Size	Torque		
		ft. lbs.	in. lbs.	Nm
Impeller Nut	7/16-20	12-18	144-215	16-24
Pump Casing (To Motor Bracket)	M6x16 Socket Head Screw	3.4	41	4.6
Motor Bracket (To Motor)	M5x142 Hex Head Bolt	6.0	96	10.8

TROUBLESHOOTING

PROBLEM	SOLUTION
• No flow or low flow	<ul style="list-style-type: none"> • Check rotation of pump • Check liquid supply to pump
• Leaking	<ul style="list-style-type: none"> • Replace shaft seal • Check case cover o-ring
• Noise	<ul style="list-style-type: none"> • Check liquid supply to pump • Check viscosity of liquid • Review NPSH requirements
• Vibration	<ul style="list-style-type: none"> • Secure plumbing to and from pump • Check impeller and replace as needed

WARRANTY

This pump is warranted for one year from date of purchase. Improper installation and use will void the warranty.

Products described hereon are covered by one or more of the following U.S. patents 3558244, 3652188, 3809508, 3920356, 3930756 and 5035580

World Headquarters

CAT PUMPS

1681 - 94th Lane N.E. Minneapolis, MN 55449-4324

Phone (763) 780-5440 — FAX (763) 780-2958

e-mail: techsupport@catpumps.com

www.catpumps.com

International Inquiries

FAX (763) 785-4329

e-mail: intlsales@catpumps.com



The Pumps with Nine Lives

CAT PUMPS (U.K.) LTD.

1 Fleet Business Park, Sandy Lane, Church Crookham, Fleet

Hampshire GU52 8BF, England

Phone Fleet 44 1252-622031 — Fax 44 1252-626655

e-mail: sales@catpumps.co.uk

N.V. CAT PUMPS INTERNATIONAL S.A.

Heiveldekens 6A, 2550 Kontich, Belgium

Phone 32-3-450.71.50 — Fax 32-3-450.71.51

e-mail: cpi@catpumps.be www.catpumps.be

CAT PUMPS DEUTSCHLAND GmbH

Buchwiese 2, D-65510 Idstein, Germany

Phone 49 6126-9303 0 — Fax 49 6126-9303 33

e-mail: catpumps@t-online.de www.catpumps.de