

## 38 Frame Block-Style Stainless Steel Plunger Pump

**Standard Models** 3801, 3811

**Flushed Models** 3801K, 3811K

### FEATURES

#### Superior Design

- Triplex plunger design gives smoother liquid flow.
- Inlet and discharge valve assemblies interchange for easier maintenance.
- Oil bath crankcase assures optimum lubrication.
- Close tolerance concentricity of the ceramic plunger maximizes seal life.
- **Standard Models:** Lo-Pressure Seals and V-Packing are completely lubricated and cooled by the liquid being pumped.
- **Flushed Models:** Special ported inlet manifold permits liquid to cool or flush between V-Packings and Lo-Pressure Seals providing protection against high temperatures or contaminating pumped liquids.

#### Quality Materials

- All stainless steel valves are heat treated and seats are roller burnished for a positive seal and extended valve life.
- 316 SSL block-style manifolds for strength and corrosion resistance.
- Special concentric, high density, polished, graphite impregnated, solid ceramic plungers are abrasion resistant and result in seal life.
- Specially formulated, CAT PUMP exclusive, V-Packings offer unmatched performance and seal life.
- Die cast aluminum crankcase provides high strength, minimum weight and precision tolerance control.
- Chrome-moly crankshaft gives unmatched strength and surface hardness.
- Oversized crankshaft bearings with greater capacity mean longer bearing life.

#### Easy Maintenance

- Wet-end is easily serviced without entering crankcase, requiring less time and effort.
- Preset packings mean no packing gland adjustment is necessary, reducing maintenance costs.

#### **⚠ WARNING**

All systems require both a primary pressure regulating device (i.e., regulator, unloader) and a secondary pressure safety relief device (i.e., pop-off valve, safety valve). Failure to install such relief devices could result in personal injury or damage to the pump or to system components. CAT PUMPS does not assume any liability or responsibility for the operation of a customer's high pressure system.

### SPECIFICATIONS

U.S. Measure

Metric Measure

#### MODEL 3801, 3801K

Flow .....9.0 GPM (34 L/M)  
Pressure Range.....100 to 5000 PSI (7 to 345 BAR)  
Bore.....0.787" (20 mm)

#### MODEL 3811, 3811K

Flow.....14 GPM (53 L/M)  
Pressure Range.....100 to 3000 PSI (7 to 210 BAR)  
Bore.....0.984" (25 mm)

#### COMMON SPECIFICATIONS

Inlet Pressure\* .....Flooded to 70 PSI (Flooded to 4.9 BAR)  
RPM .....800 RPM (800 RPM)  
Stroke.....1.890" (48 mm)  
Crankcase Capacity.....4.2 Qts. (4 L)  
Maximum Liquid Temperature .....160°F (71°C)  
Inlet Ports (2) .....1-1/2" NPTF (1-1/2" NPTF)  
Flushing Ports (2) .....1/2" NPTF (1/2" NPTF)  
Discharge Ports (2).....1" NPTF (1" NPTF)  
Pulley Mounting .....Either Side (Either Side)  
Shaft Diameter .....1.378" (35 mm)  
Weight.....170 lbs. (77 kg)  
Dimensions .....24.65 x 18.11 x 9.72" (626 x 460 x 247 mm)

\*"K" models have special inlet ports for cooling/flushing, containment of hazardous liquids and high inlet pressure. Consult CAT PUMPS for additional information.

### HORSEPOWER REQUIREMENTS

MODEL	FLOW		PRESSURE							RPM
			PSI 2000	PSI 2500	PSI 3000	PSI 3500	PSI 4000	PSI 4500	PSI 5000	
	U.S. GPM	L/M	BAR 140	BAR 175	BAR 210	BAR 245	BAR 275	BAR 310	BAR 345	
<b>3801</b>	9	34	N/A	N/A	N/A	21.6	24.7	27.8	30.9	800
<b>3801K</b>	8	30	N/A	N/A	N/A	19.2	22.0	24.7	27.5	711
	7	27	N/A	N/A	N/A	16.8	19.2	21.6	24.0	622
<b>3811</b>	14	53	19.2	24.0	28.8	N/A	N/A	N/A	N/A	800
	12	45	16.5	20.6	24.7	N/A	N/A	N/A	N/A	685
	10	38	13.7	17.2	20.6	N/A	N/A	N/A	N/A	571

**DETERMINING THE PUMP R.P.M.** Rated G.P.M. = "Desired" G.P.M.  
Rated R.P.M. "Desired" R.P.M.

**DETERMINING THE REQUIRED H.P.** GPM x PSI = Electric Brake  
1460 H. P. Required

**DETERMINING MOTOR PULLEY SIZE** Motor Pulley O.D. = Pump Pulley O.D.  
Pump R.P.M. Motor R.P.M.

See complete Drive Packages [Incls: Pulleys, Belts, Hubs, Key] Tech Bulletin 003.  
Refer to pump Service Manual for repair procedure and additional technical information.

*"Customer confidence is our greatest asset"*

# PARTS LIST

ITEM	PART NUMBER		PART NUMBER		PART NUMBER		PART NUMBER		DESCRIPTION	QTY
	3801	MATL	3801K	MATL	3811	MATL	3811K	MATL		
2	34021	STL	34021	STL	34021	STL	34021	STL	Key (M10x8x70)	1
5	118824	S	118824	S	118824	S	118824	S	Screw, Sems HH (M8x25)	8
8	44542	AL	44542	AL	44542	AL	44542	AL	Cover, Bearing	2
	701138	F	701138	F	701138	F	701138	F	Cover, Bearing (Use w/701139, 140, 145, 147, 428)	2
9	44543	FBR	44543	FBR	44543	FBR	44543	FBR	Shim, Bearing Cover	0-2
10	12398	NBR	12398	NBR	12398	NBR	12398	NBR	O-Ring, Bearing Cover - 70D	2
11	13296	NBR	13296	NBR	13296	NBR	13296	NBR	Seal, Oil, Crankshaft	2
12	43642	S	43642	S	43642	S	43642	S	Washer, Shim (M120x.3)	0-1
13	43643	S	43643	S	43643	S	43643	S	Washer, Shim (M120x.5)	0-1
15	29326	STL	29326	STL	29326	STL	29326	STL	Bearing, Roller	2
20	121467	TNM	121467	TNM	121467	TNM	121467	TNM	Rod, Connecting Assembly [10/00]	3
21	44940	STZP	44940	STZP	44940	STZP	44940	STZP	Washer, Locking (M10)	3
22	43641	STZP	43641	STZP	43641	STZP	43641	STZP	Washer (M10.5x1.5) STZP <span style="border: 1px solid black; padding: 2px;">Replace as a set</span>	6
23	88155	STZP	88155	STZP	88155	STZP	88155	STZP	Screw, HH (M10x60)	6
25	29325	FCM	29325	FCM	29325	FCM	29325	FCM	Crankshaft, Dual End	1
31	828710		828710		828710		828710		Protector, Oil Cap	1
32	43211	ABS	43211	ABS	43211	ABS	43211	ABS	Cap, Oil Filler	1
33	14177	NBR	14177	NBR	14177	NBR	14177	NBR	O-Ring, Oil Filler Cap - 70D	1
34	44319	STZP	44319	STZP	44319	STZP	44319	STZP	Bolt, Eye (M12)	1
35	701145	AL	701145	AL	701145	AL	701145	AL	Rivet, Serial Plate (Use w/701138, 139, 140, 147, 428)	1
36	701147	AL	701147	AL	701147	AL	701147	AL	Plate, Name (Use w/701138, 139, 140, 145, 428)	1
37	92241		92241		92241		92241		Gauge, Oil, Bubble w/Gasket - 80D	1
38	44428	NBR	44428	NBR	44428	NBR	44428	NBR	Gasket, Flat, Oil Gauge - 80D	1
40	118824	S	118824	S	118824	S	118824	S	Screw, Sems HH (M8x25)	8
48	25625	STCP	25625	STCP	25625	STCP	25625	STCP	Plug, Drain (1/4"x19BSP)	1
49	23170	NBR	23170	NBR	23170	NBR	23170	NBR	O-Ring, Drain Plug - 70D	1
50	45936	AL	45936	AL	45936	AL	45936	AL	Cover, Rear	1
	701139	F	701139	F	701139	F	701139	F	Cover, Rear (Use w/701138, 140, 145, 147, 428)	1
51	16612	NBR	16612	NBR	16612	NBR	16612	NBR	O-Ring, Cover, Rear - 70D	1
53	44559	AL	44559	AL	44559	AL	44559	AL	Crankcase	1
	701428	F	701428	F	701428	F	701428	F	Crankcase (Use w/701138, 139, 140, 145, 147)	1
55	27488	S	27488	S	27488	S	27488	S	Pin, Guide	2
56	27790	PE	27790	PE	27790	PE	27790	PE	Pan, Oil	1
57	19933	S	19933	S	19933	S	19933	S	Washer (M6)	2
58	15849	S	15849	S	15849	S	15849	S	Lockwasher, Split (M6)	2
59	89618	S	89618	S	89618	S	89618	S	Screw, HH (M6x16)	2
64	43864	CM	43864	CM	43864	CM	43864	CM	Pin, Crosshead	3
65	45118	SSZZ	45118	SSZZ	45118	SSZZ	45118	SSZZ	Rod, Plunger	3
69	29338	STZP	29338	STZP	29338	STZP	29338	STZP	Seal, Washer, Oil	3
70	100488	NBR	100488	NBR	100488	NBR	100488	NBR	Seal, Oil, Crankcase	3
75	43506	S	43506	S	43865	S	43865	S	Slinger, Barrier	3
88	45675	SS	45675	SS	45676	SS	45676	SS	Washer, Keyhole	3
90	43945	CC	43945	CC	43866	CC	43866	CC	Plunger (M20x145) (M25x145)	3
95	89779	S	89779	S	89778	SS	89778	SS	Stud, Plunger Retainer (M7x123) (M10x135)	3
96	20184	PTFE	20184	PTFE	20189	PTFE	20189	PTFE	Back-up-Ring, Plunger Retainer	3
97	14190	NBR	14190	NBR	11345	NBR	11345	NBR	O-Ring, Plunger Retainer - 70D	3
	14161	FPM	14161	FPM	11375	FPM	11375	FPM	O-Ring, Plunger Retainer - 70D	3
	701652	EPDM	701652	EPDM	701490	EPDM	701490	EPDM	O-Ring, Plunger Retainer - 70D	3
98	44069	SSL	44069	SSL	44085	SS	44085	SS	Gasket	3
99	44068	SSL	44068	SSL	44084	SS	44084	SS	Retainer, Plunger	3
100	814279	PVDF	814279	PVDF	814279	PVDF	814279	PVDF	Retainer, Seal, 2 Pc.	3
101	44095		44095		44096		44096		Wick	3
104	43875	NBR	43875	NBR	43875	NBR	43875	NBR	O-Ring, Inlet Adapter - 70D	3
	44826	FPM	44826	FPM	44826	FPM	44826	FPM	O-Ring, Inlet Adapter - 70D	3
	701656	EPDM	701656	EPDM	701656	EPDM	701656	EPDM	O-Ring, Inlet Adapter - 70D	3
105	701344	SS	701344	SS	701323	SS	701323	SS	Adapter, Inlet	3
106	44071	NBR	44071	NBR	44086	NBR	44086	NBR	Seal, LPS w/SS-Spg	3
	44381	FPM	44381	FPM	45846	FPM	45846	FPM	Seal, LPS w/SS-Spg	3
	701974	SFTB*	701974	SFTB*	701944	SFTA*	701944	SFTA*	Seal, LPS w/SS-Spg	3
107	44074	SS	44074	SS	44089	SS	44089	SS	Washer, LPS Seal	3
110	701286	SSL	701286	SSL	701286	SSL	701286	SSL	Manifold, Inlet, Block-Style	1
			701408	SSL			701408	SSL	Manifold, Inlet, Block-Style, Flushed	1
111	701116	SS	701116	SS	701116	SS	701116	SS	Plug, Inlet (1-1/2" NPT)	1
112	701794	NBR	701794	NBR	701794	NBR	701794	NBR	O-Ring, Inlet Spacer	6
	701318	FPM	701318	FPM	701318	FPM	701318	FPM	O-Ring, Inlet Spacer	6
	701495	EPDM	701495	EPDM	701495	EPDM	701495	EPDM	O-Ring, Inlet Spacer	6
113	701319	PTFE	701319	PTFE	701319	PTFE	701319	PTFE	Back-up-Ring, Spacer	6
114	701317	SS	701317	SS	701317	SS	701317	SS	Spacer, Inlet	3
117	701252	SS	701252	SS	701252	SS	701252	SS	Screw, HSH (M14x100)	4
123	12391	NBR	12391	NBR	12391	NBR	12391	NBR	O-Ring, V-Packing Cylinder - 70D	3
	13266	FPM	13266	FPM	13266	FPM	13266	FPM	O-Ring, V-Packing Cylinder - 70D	3
	701657	EPDM	701657	EPDM	701657	EPDM	701657	EPDM	O-Ring, V-Packing Cylinder - 70D	3
124	701336	SSL	701336	SSL	701448	SSL	701448	SSL	Cylinder, V-Packing	3
126	44164	SS	44164	SS	701325	SS	701325	SS	Adapter, Female	3
127	44607	STG*	44607	STG*	44610	STG*	44610	STG*	V-Packing	9-6
128	44165	SS	44165	SS	701326	SS	701326	SS	Adapter, Male	3
141	—	—	—	—	45113	SS	45113	SS	Spring	15
142	—	—	—	—	701447	SS	701447	SS	Spacer w/Coil springs	3
155	17622	NBR	17622	NBR	11379	NBR	11379	NBR	O-Ring, V-Packing Spacer	3
	11719	FPM	11719	FPM	14183	FPM	14183	FPM	O-Ring, V-Packing Spacer	3
	701654	EPDM	701654	EPDM	701491	EPDM	701491	EPDM	O-Ring, V-Packing Spacer	3
156	28675	PTFE	28675	PTFE	28243	PTFE	28243	PTFE	Back-up-Ring, V-Packing Spacer	3
157	701352	SS	701352	SS	701385	SS	701385	SS	Spacer, V-Packing	3
158	28675	PTFE	28675	PTFE	28243	PTFE	28243	PTFE	Back-up-Ring, V-Packing Spacer	3
159	17622	NBR	17622	NBR	11379	NBR	11379	NBR	O-Ring, V-Packing Spacer	3
	11719	FPM	11719	FPM	14183	FPM	14183	FPM	O-Ring, V-Packing Spacer	3
	701654	EPDM	701654	EPDM	701491	EPDM	701491	EPDM	O-Ring, V-Packing Spacer	3
162	21985	PTFE	21985	PTFE	21985	PTFE	21985	PTFE	Back-up-Ring, Seat	6
163	26089	NBR	26089	NBR	26089	NBR	26089	NBR	O-Ring, Seat - 80D	6
	11377	FPM	11377	FPM	11377	FPM	11377	FPM	O-Ring, Seat - 80D	6
	701655	EPDM	701655	EPDM	701655	EPDM	701655	EPDM	O-Ring, Seat - 80D	6
164	44080	SS	44080	SS	44080	SS	44080	SS	Seat	6
166	44081	SS	44081	SS	44081	SS	44081	SS	Valve	6
167	44082	SS	44082	SS	44082	SS	44082	SS	Spring	6
168	44735	PVDF	44735	PVDF	44735	PVDF	44735	PVDF	Retainer, Spring	6

# EXPLODED VIEW

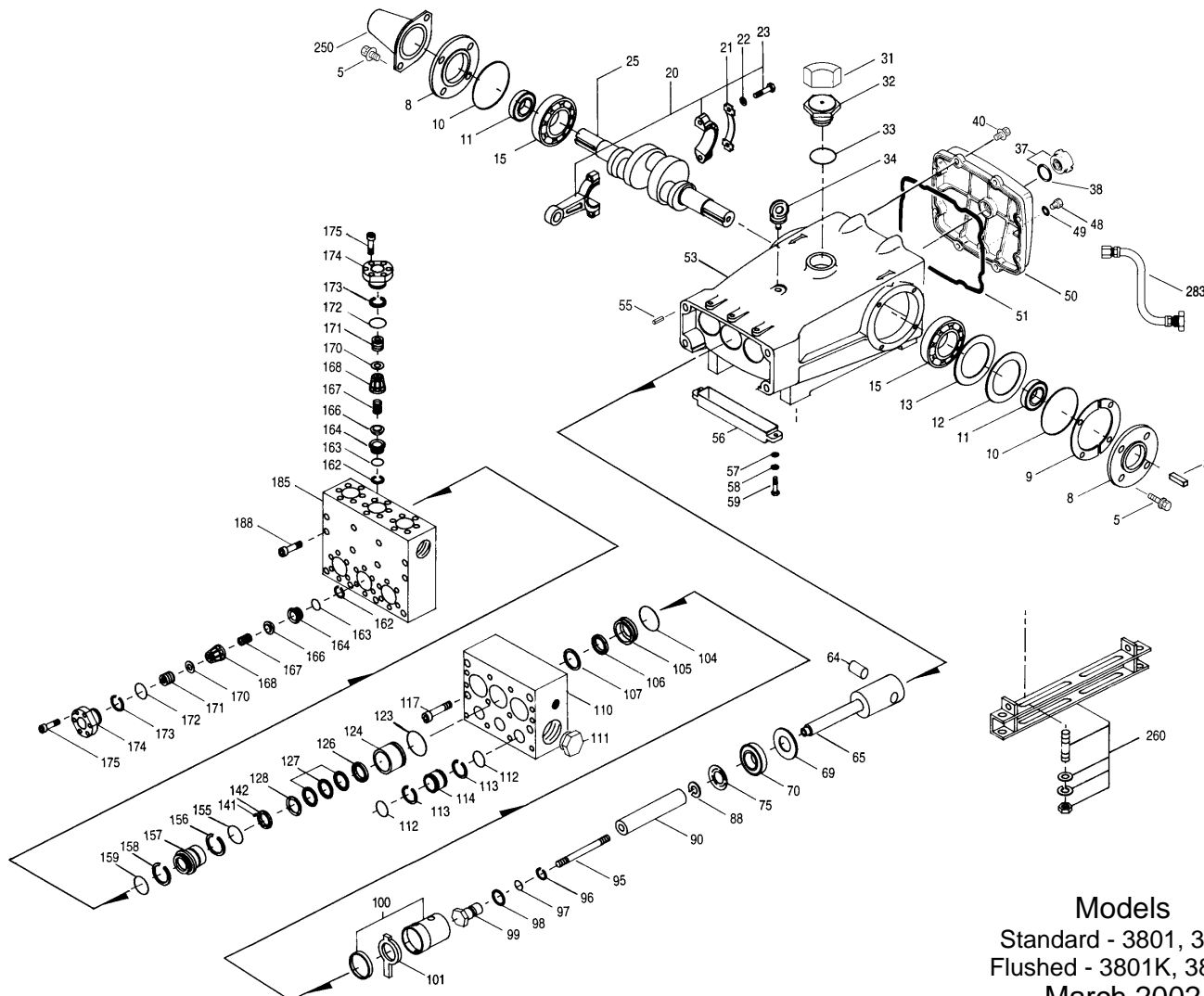

**Models**  
 Standard - 3801, 3811  
 Flushed - 3801K, 3811K  
 March 2002

	<b>3801</b>	<b>MATL</b>	<b>3801K</b>	<b>MATL</b>	<b>3811</b>	<b>MATL</b>	<b>3811K</b>	<b>MATL</b>		
170	44794	SS	44794	SS	44794	SS	44794	SS	Washer, Spring Retainer	6
171	44793	SS	44793	SS	44793	SS	44793	SS	Spring, Coil, Valve Plug	6
172	15853	NBR	15853	NBR	15853	NBR	15853	NBR	O-Ring, Valve Plug - 70D	6
	11720	FPM	11720	FPM	11720	FPM	11720	FPM	O-Ring, Valve Plug - 70D	6
	♦ 701481	EPDM	♦ 701481	EPDM	♦ 701481	EPDM	♦ 701481	EPDM	O-Ring, Valve Plug - 70D	6
173	20224	PTFE	20224	PTFE	20224	PTFE	20224	PTFE	Back-up-Ring, Valve Plug	6
174	701260	SS	701260	SS	701260	SS	701260	SS	Plug, Valve	6
175	87951	S	87951	S	87951	S	87951	S	Screw, HSH, Valve Plug (M10x30)	36
● 185	<b>701314</b>	<b>SSL</b>	<b>701314</b>	<b>SSL</b>	<b>701785</b>	<b>SSL</b>	<b>701785</b>	<b>SSL</b>	Manifold, Discharge, Block-Style	1 ●
188	701279	S	701279	S	701279	S	701279	S	Screw, HSH, (M12x100)	12
● 250	44516	NY	44516	NY	44516	NY	44516	NY	Protector, Shaft w/2 Screws (89283)	1 ●
●	701140	F	701140	F	701140	F	701140	F	Protector, Shaft w/2 Screws (89283) (Use w/701138, 139, 145, 147, 428)	1 ●
● 255	34039	SS	34039	SS	34039	SS	34039	SS	Kit, Stud Mount	1 ●
● 260	92674	STZP	92674	STZP	92674	STZP	92674	STZP	Mount, Rail, Assy (Incls: 43888,34018)	1 ●
● 275	990013	STL	990013	STL	990013	STL	990013	STL	Hub, "B" (Keyway M10x8x70) [See Drive Packages Tech 003]	1 ●
● 279	<b>30278</b>	<b>STZP</b>	—	—	<b>30278</b>	<b>STZP</b>	—	—	Oiler (1 oz.)	3 ●
281	<b>30967</b>	—	—	—	<b>30967</b>	—	—	—	Glass, Oiler	1 ●
282	<b>10069</b>	<b>NBR</b>	—	—	<b>10069</b>	<b>NBR</b>	—	—	Gasket, Oiler	3 ●
● 283	34334	—	34334	—	34334	—	34334	—	Kit, Oil Drain	1 ●
● 290	6104	—	6104	—	6104	—	6104	—	Gasket, Liquid (1 oz.)	1 ●
● 299	<b>901388</b>	<b>SSL</b>	<b>901389</b>	<b>SSL</b>	<b>901370</b>	<b>SSL</b>	<b>901371</b>	<b>SSL</b>	Head, Complete, Block-Style	1 ●
300	<b>701786</b>	<b>NBR*</b>	<b>701786</b>	<b>NBR*</b>	<b>701793</b>	<b>NBR*</b>	<b>701793</b>	<b>NBR*</b>	Kit, Seal (Incls: 97, 104, 106, 112, 113, 123, 127, 155, 156, 158, 159)	1
	<b>33251</b>	<b>FPM*</b>	<b>33251</b>	<b>FPM*</b>	<b>701802</b>	<b>FPM*</b>	<b>701802</b>	<b>FPM*</b>	Kit, Seal (Incls: 97, 104, 106, 112, 113, 123, 127, 155, 156, 158, 159)	1
	♦ <b>33141</b>	<b>EPDM*</b>	♦ <b>33141</b>	<b>EPDM*</b>	♦ <b>701803</b>	<b>EPDM*</b>	♦ <b>701803</b>	<b>EPDM*</b>	Kit, Seal (Incls: 97, 104, 106, 112, 113, 123, 127, 155, 156, 158, 159)	1
310	34151	NBR	34151	NBR	34151	NBR	34151	NBR	Kit, Valve (Incls: 162, 163, 164, 166, 167, 168, 170, 172, 173)	2
	701798	FPM	701798	FPM	701798	FPM	701798	FPM	Kit, Valve (Incls: 162, 163, 164, 166, 167, 168, 170, 172, 173)	2
	♦ 701799	EPDM	♦ 701799	EPDM	♦ 701799	EPDM	♦ 701799	EPDM	Kit, Valve (Incls: 162, 163, 164, 166, 167, 168, 170, 172, 173)	2
● —	819000	F	819000	F	819000	F	819000	F	Crankcase Assembly, CAST IRON Conversion	1 ●
● 370	—	—	<b>990663</b>	—	—	—	<b>990663</b>	—	Assembly, Flushing, 5 gal, 115V, 1.1 Amp, 1/2"NPT	1 ●
● —	711500	SS	711500	SS	711500	SS	711500	SS	C.A.T. (For R.O. or Industrial Applications)	1 ●
● —	711506	SS	711506	SS	711506	SS	711506	SS	Adapter (2 per C.A.T.) (See Data Sheet for complete selection)	1 ●
—	6100	—	6100	—	6100	—	6100	—	Oil, Case (12-21 oz. Bottles) ISO 68 Multi-Viscosity Hydraulic (Fill to specified crankcase capacity prior to start-up)	1

● Industrial discount. **Bold print part numbers are unique to a particular pump model.** *Italics are optional items.* ♦ Silicone oil/grease required. [ ] Date of latest production change.

**Pressurized inlet and C.A.T. highly recommended for Hi-Temp, R.O. and industrial applications.** See Tech Bulletins 002, 003, 024, 036, 041, 053, 074, 077 and 083 for additional information.

\* Review material codes for individual items (STG, SFTA, SFTB generally may be used as alternates).

MATERIAL CODES (Not Part of Part Number): ABS=ABS Plastic AL=Aluminum CC=Ceramic CM=Chrome-Moly EPDM=Ethylene Propylene Diene Monomer F=Cast Iron FBR=Fiber

FCM=Forged Chrome-moly FPM=Fluorocarbon (Viton®) NBR=Medium Nitrile (Buna-N) NBR-S=Buna, Silicone Free NY=Nylon PE=Polyethylene PTFE=Pure Teflon®

PVDF=Fluoroplastic (High Strength) SFTA=Special Blend (Teflon®) Tan SFTB=Special Blend (Teflon®) Black S=304SS SS=316SS SSL=316SS/Low Carbon

SSZZ=316SS/Zamak STG=Special Blend (Teflon®) White STL=Steel STZP=Steel/Zinc Plated TNM=Special High Strength

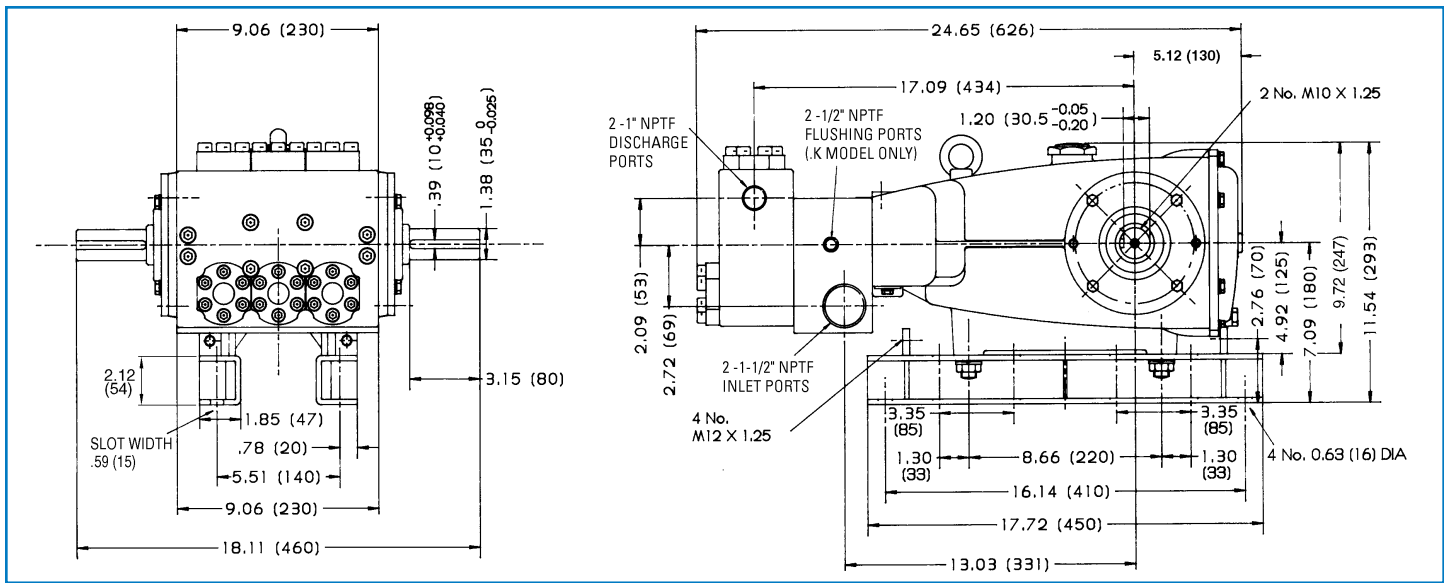

Models 3801, 3801K, 3811, 3811K

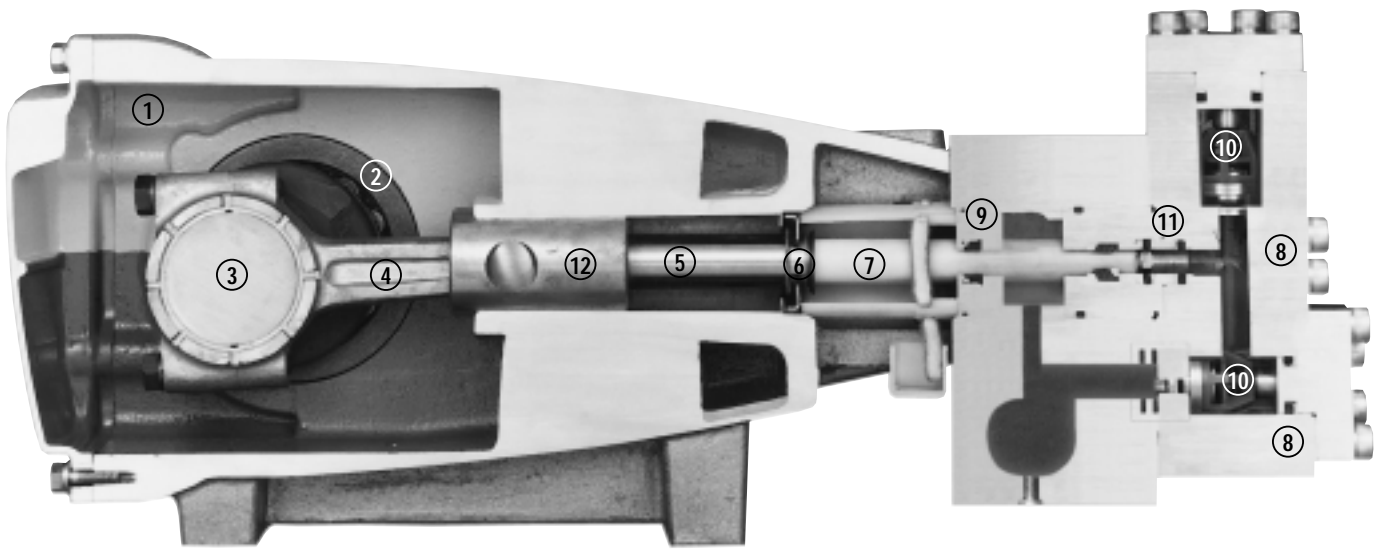

- 1 Die cast aluminum **crankcase** means high strength, lightweight, and excellent tolerance control.
- 2 Oversized crankshaft **bearings** provide extended bearing life and pump performance.
- 3 Chrome-moly **crankshaft** provides unmatched strength and surface hardness for long life.
- 4 Matched oversized high strength **connecting rods** are noted for superior strength and bearing quality.
- 5 Special stainless steel **plunger rods** with high strength crossheads for longevity and corrosion resistance.

- 6 The stainless steel **slinger** provides back-up protection for the crankcase seal, keeping pumped liquids out of the crankcase.
- 7 Special concentric, high density, polished, graphite impregnated, solid ceramic **plungers** are abrasion resistant and result in extended seal life.
- 8 **Manifolds** are 316 SSL block-style for long-term continuous-duty and corrosion resistance.
- 9 **Standard Models:** Lo Pressure Seals and V-Packings are completely lubricated and cooled by the liquid being pumped.

- 9 **Flushed Models:** Special ported inlet manifold permits liquid to cool or flush between V-Packings and Lo-Pressure Seals providing protection against high temperatures or contaminating pumped liquids.
- 10 Stainless steel **valves, seats and springs** provide corrosion-resistance, positive seating and long life.
- 11 Specially formulated, CAT PUMP exclusive, **V-Packings** offer unmatched performance and seal life.
- 12 **Crossheads** are 360° supported for uncompromising alignment.

Products described hereon are covered by one or more of the following U.S. patents 3558244, 3652188, 3809508, 3920356, 3930756 and 5035580

**World Headquarters**  
**CAT PUMPS**  
 1681 - 94th Lane N.E. Minneapolis, MN 55449-4324  
 Phone (763) 780-5440 — FAX (763) 780-2958  
 e-mail: sales@catpumps.com  
 www.catpumps.com

**International Inquiries**  
 FAX (763) 785-4329  
 e-mail: intlsales@catpumps.com



**CAT PUMPS (U.K.) LTD.**  
 1 Fleet Business Park, Sandy Lane, Church Crookham, Fleet  
 Hampshire GU52 8BF, England  
 Phone Fleet 44 1252-622031 — Fax 44 1252-626655  
 e-mail: sales@catpumps.co.uk

**N.V. CAT PUMPS INTERNATIONAL S.A.**  
 Heiveldekens 6A, 2550 Kontich, Belgium  
 Phone 32-3-450.71.50 — Fax 32-3-450.71.51  
 e-mail: cpi@catpumps.be www.catpumps.be

**CAT PUMPS DEUTSCHLAND GmbH**  
 Buchwiese 2, D-65510 Idstein, Germany  
 Phone 49 6126-9303 0 — Fax 49 6126-9303 33  
 e-mail: catpumps@t-online.de www.catpumps.de