



Model 280 shown

3 Frame Piston Pump Models

280 290

FEATURES

Superior Design

- Triplex Uniflow design provides continuous forward liquid flow for smooth operation.
- Wetted cups and floating pistons are lubricated and cooled by pumped liquid for long cup life.
- Mechanically actuated inlet valves give strong lift and easy prime.
- 304 stainless steel discharge valves for wear resistance.
- Oil bath crankcase assures optimum lubrication.
- 100% wetted seal design allows pumped liquid to cool and lubricate for longer life.

Quality Materials

- Cylinder and sleeve wear surfaces are hard chrome plated 304 stainless steel for maximum durability and abrasion resistance.
- Chrome plated, brass manifolds and optional stainless steel manifolds are strong and corrosion resistant.
- Special high strength TNM connecting rods offer superior bearing quality strength.
- Chrome-moly crankshaft gives unmatched strength and surface hardness.
- Oversized crankshaft bearings with greater loading capacity mean longer bearing life.

Easy Maintenance

- Stepped stainless steel piston rod with chrome-plated, stainless steel sleeve allows easy replacement from front of pump.
- All wet-end wear parts are easily serviced without entering crankcase, requiring less time and effort.
- Wear parts are available in convenient kits.

⚠ WARNING

All systems require both a primary pressure regulating device (i.e., regulator, unloader) and a secondary pressure safety relief device (i.e., pop-off valve, safety valve). Failure to install such relief devices could result in personal injury or damage to the pump or to system components. CAT PUMPS does not assume any liability or responsibility for the operation of a customer's high pressure system.

SPECIFICATIONS

U.S. Measure

Metric Measure

MODEL 280

Flow.....	3.0 GPM	(11.4 L/M)
Pressure Range.....	100 to 1000 PSI	(7 to 70 Bar)
RPM	1330 RPM	(1330 RPM)
Stroke.....	0.394"	(10 mm)
Weight.....	11.7 lbs.	(5.3 kg)

MODEL 290

Flow.....	3.5 GPM	(13.2 L/M)
Pressure Range.....	100 to 1200 PSI	(7 to 85 BAR)
RPM	1200 RPM	(1200 RPM)
Stroke.....	0.472"	(12 mm)
Weight.....	12.1 lbs.	(5.5 kg)

COMMON SPECIFICATIONS

Inlet Pressure Range	-8.5 to 40 PSI	(-0.6 to + 2.8 BAR)
Bore.....	0.787"	(20 mm)
Crankcase Capacity	10 oz.	(.3 L)
Maximum Liquid Temperature	160°F	(71°C)
Above 130°F call CAT PUMPS for inlet conditions and elastomer recommendations.		
Inlet Port (1)	1/2" NPTF	(1/2" NPTF)
Chemical Injection Port (1)	1/4" NPTF	(1/4" NPTF)
Discharge Ports (2).....	3/8" NPTF	(3/8" NPTF)
Discharge Port (1).....	1/2" NPTF	(1/2" NPTF)
Pulley Mounting.....	Either side	(Either side)
Shaft Diameters	0.650"	(16.5 mm)
Dimensions (280)	10.63 x 8.79 x 5.30"	(270 x 223x 134.5 mm)
Dimensions (290)	10.83 x 8.79 x 5.30"	(275 x 223x 134.5 mm)

HORSEPOWER REQUIREMENTS

MODEL	FLOW		PRESSURE			MOTOR PULLEY SIZE	
	U.S. GPM	L/M	PSI 800	PSI 1000	PSI 1200	Using 1725 Nom. RPM Motor & 5.0" Pump Pulley O.D.	
			BAR 55	BAR 70	BAR 85	RPM	Pulley O.D.
280	3.0	11.4	1.6	2.1	N/A	1330	3.9
	2.5	9.5	1.4	1.7	N/A	1108	3.2
	2.0	7.6	1.1	1.4	N/A	887	2.8
290	3.5	13.2	1.9	2.4	2.9	1200	3.5
	3.0	11.4	1.6	2.1	2.5	1029	3.0
	2.5	9.5	1.4	1.7	2.1	858	2.5

DETERMINING THE PUMP R.P.M. $\frac{\text{Rated G.P.M.}}{\text{Rated R.P.M.}}$ = "Desired" G.P.M. / "Desired" R.P.M.

DETERMINING THE REQUIRED H.P. $\frac{\text{GPM} \times \text{PSI}}{1460}$ = Electric Brake H. P. Required

DETERMINING MOTOR PULLEY SIZE $\frac{\text{Motor Pulley O.D.}}{\text{Pump R.P.M.}}$ = $\frac{\text{Pump Pulley O.D.}}{\text{Motor R.P.M.}}$

See complete Drive Packages [Incls: Pulleys, Belts, Hubs, Key] Tech Bulletin 003.
Refer to pump Service Manual for repair procedure and additional technical information.

"Customer confidence is our greatest asset"

PARTS LIST

ITEM	PART NUMBER		DESCRIPTION	QTY		
	280	MATL	290	MATL		
2	30047	STL	30047	STL	Key (M5x5x24)	1
5	92519	STZP	92519	STZP	Screw, Sems HHC (M6x16)	8
8	27950	AL	27950	AL	Cover, Bearing	2
10	26536	NBR	26536	NBR	O-Ring, Bearing Cover - 70D	2
11	24159	NBR	24159	NBR	Seal, Oil, Crankshaft	2
15	14487	STL	14487	STL	Bearing, Ball	2
20	122041	TNM	48867	TNM	Rod, Assy Connecting [280-8/02, 290-9/02]	3
25	26239	FCM	43804	FCM	Crankshaft	1
31	828710	—	828710	—	Protector, Oil Cap	1
32	43211	ABS	43211	ABS	Cap, Oil Filler	1
33	14177	NBR	14177	NBR	O-Ring, Oil Filler Cap - 70D	1
37	92241	—	92241	—	Gauge, Oil Bubble w/Gasket - 80D	1
38	44428	NBR	44428	NBR	Gasket, Flat, Oil Gauge - 80D	1
40	92520	STZP	92520	STZP	Screw, Sems HHC (M6x20)	4
48	25625	STCP	25625	STCP	Plug, Drain (1/4"x19BSP)	1
49	23170	NBR	23170	NBR	O-Ring, Drain Plug - 70D	1
50	43339	AL	43339	AL	Cover, Rear	1
51	43340	NBR	43340	NBR	O-Ring, Rear Cover	1
53	44658	AL	44658	AL	Crankcase, 4 Screws	1
55	14137	STCP	—	—	Stud (M8x41.4)	2
64	16948	CM	16948	CM	Pin, Crosshead	3
65	29612	SZZ	101800	SZZ	Rod, Piston	3
69	20017	STZP	20017	STZP	Washer, Oil Seal	3
70	25301	NBR	25301	NBR	Seal, Oil - 80D	3
71	26854	STZP	26854	STZP	Washer, Oil Seal	3
75	25327	S	25327	S	Slinger, Barrier	3
77	25392	NBR	25392	NBR	O-Ring, Sleeve	6
	28771	FPM	28771	FPM	O-Ring, Sleeve	6
80	29614	SCP	29614	SCP	Sleeve	3
	29743	S	29743	S	Sleeve	3
81	—	—	29003	PTFE	Back-up-Ring, Sleeve	3
100	28597	PVDF	28597	PVDF	Retainer, Seal	3
106	30315	NBR	30315	NBR	Seal, LPS, Prrrrrm-A-Lube	3
	30325	FPM	30325	FPM	Seal, LPS, Prrrrrm-A-Lube	3
109	22177	BBCP	22177	BBCP	Plug HH (1/4" NPT)	1
110	25128	BBCP	25128	BBCP	Manifold, Inlet	1
	25635	SS	25635	SS	Manifold, Inlet	1
117	—	—	85680	STZP	Stud (M8x99.5)	2
118	22160	BBCP	22160	BBCP	Elbow (1/2" NPT)	1
119	27004	S	27004	S	Valve, Inlet	3
130	22021	S	30543	S	Piston	3
131	—	—	30544	PTFE	Bac-Cup Ring	3
133	43172	FPM	43172	FPM	Cup, Piston	3
133	—	—	43474	FPM	Assy, Bac-Cup (Incls: 130, 131, 133) (290 Only)	3
133	29089	SNG	29089	SNG	Cup, V-Hot	3
135	27003	S	27983	S	Spacer, Piston	3
136	27002	S	27002	S	Retainer, Piston	3
137	27006	S	27006	S	Washer, Conical (M6)	3
138	27000	S	27000	S	Nut (M6)	3
139	14158	S	14158	S	Cotterpin (M1.6x10)	3
143	23172	NBR	23172	NBR	O-Ring, Cylinder -70D	6
	11377	FPM	11377	FPM	O-Ring, Cylinder -80D	6
	26961	PTFE	26961	PTFE	O-Ring, Cylinder	3
150	26112	SCP	101802	SCP	Cylinder	3
	28774	S	43834	S	Cylinder	3
153	—	—	21985	PTFE	Back-Up-Ring, Cylinder	3
164	43434	S	43434	S	Seat, Q.V.	3
	29487	S	29487	S	Seat, F.V.	3
166	43723	S	43723	S	Valve, Q.V.	3
	22842	S	22842	S	Valve, F.V.	3
167	43360	S	43360	S	Spring, Q.V.	3
	22031	S	22031	S	Spring, F.V.	3
168	43442	S	43442	S	Retainer, Spring, Q.V.	3
	22841	S	22841	S	Retainer, Spring, F.V.	3
184	—	—	81109	STZP	Nut, Hex (M8)	2
185	24459	BBCP	24459	BBCP	Manifold, Discharge	1
	25634	SS	25634	SS	Manifold, Discharge	1
186	15845	STZP	—	—	Lockwasher (M8)	2
187	26245	STZP	—	—	Bolt, Cylinder (M8x62.5)	2
188	22902	STZP	—	—	Shim (M8x13x1.0)	2-4
189	13533	STZP	—	—	Shim (M8x13x0.5)	2-4
190	43258	STZP	—	—	Shim (M8x13x0.3)	2-4
191	43425	STZP	—	—	Shim (M8x13x2.0)	2-4
192	26676	STZP	—	—	Lock, Washer (M8)	2
194	101804	STZP	101804	STZP	Nut, Hex Flange (M8)	2
196	22187	BBCP	22187	BBCP	Plug HH (3/8" NPT)	1
250	25130	STCP	25130	STCP	Protector, Shaft	1
260	30612	STZP	30612	STZP	Assy, Angle Rail (Incls: 26246, 30901, 30920, 30910)	1
270	30246	STL	30246	STL	Pulley Assy (Incls: 30032, 30047)	1

EXPLODED VIEW

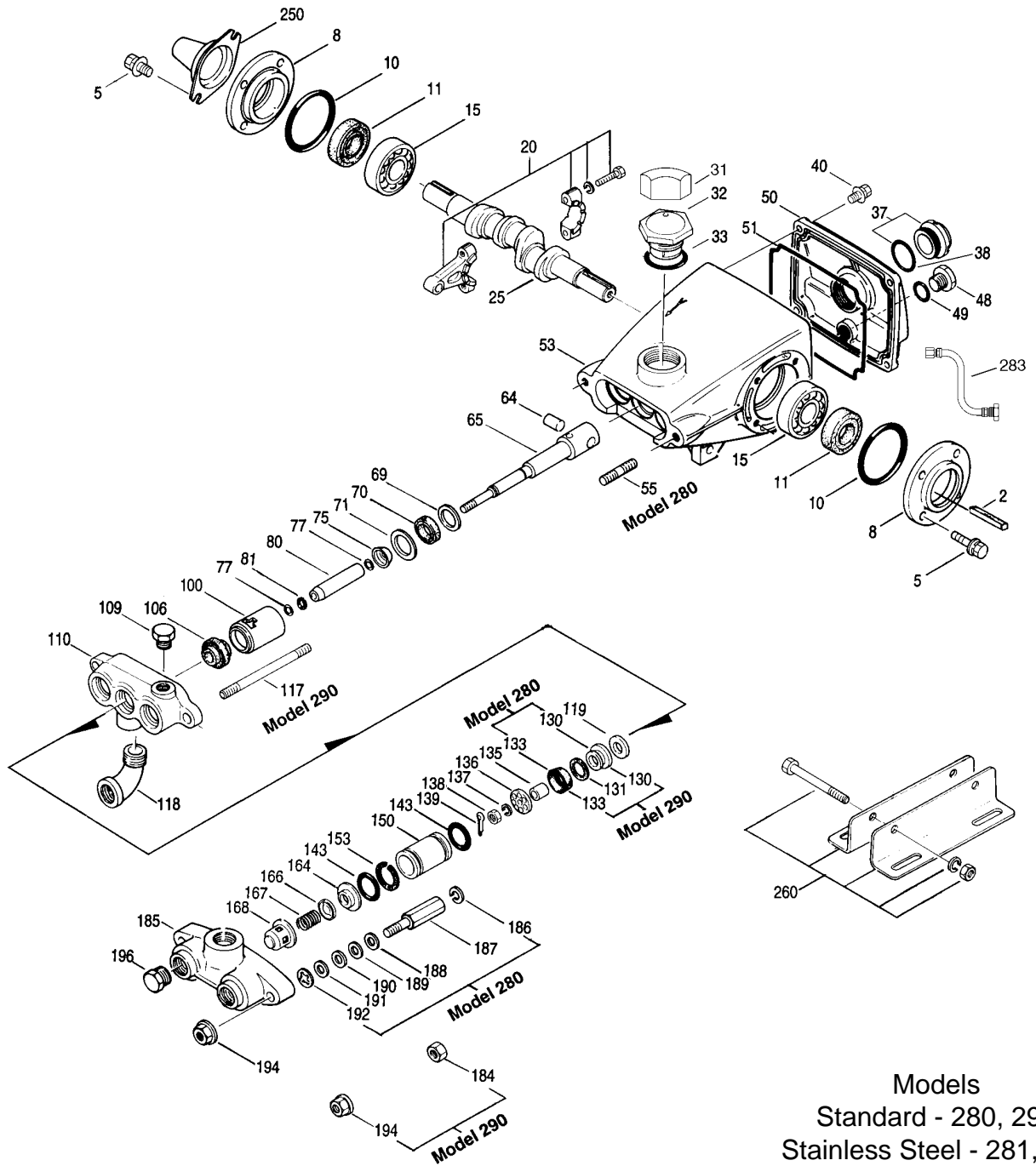

Models
Standard - 280, 290
Stainless Steel - 281, 291
July 2003

	280	MATL	290	MATL		
275	30942	STL	30942	STL	Hub & Key Assy (Incls: 30943, 30047)	1
283	34334	—	34334	—	Kit, Oil Drain	1
298	34961	STZP	34961	STZP	Clutch, Assy, Single Groove, 16.5mm, 12VDC	1
	34964	STZP	34964	STZP	Clutch, Assy, Dual Groove, 16.5mm, 12VDC	1
300	30023	FPM	30023	FPM	Kit, Cup (Incls: 133, 139, 143, 355)	1
302	30202	NBR	30860	NBR	Kit, Piston (Incls: 119-139, 143, 153, 355)	1
305	30431	NBR	30431	NBR	Kit, Sleeve & Seal (Incls: 75, 77, 80, 106, 139)	1
306	30305	NBR	30305	NBR	Kit, Seal (Incls: 106, 139)	1
310	30686	NBR	30686	NBR	Kit, Valve, Q.V. (Incls: 143, 164, 166, 167, 168)	1
	30024	NBR	30024	NBR	Kit, Valve, F.V. (Incls: 143, 164, 166, 167, 168)	1
355	22130	NY	22130	NY	Insertor, Cup	1
	6107	—	6107	—	Oil, Bottle (21 oz.) ISO 68 Multi-viscosity Hydraulic (Fill to specified crankcase capacity prior to start-up)	1

Bold print part numbers are unique to a particular pump model. Italics are optional items. [] Date of latest production change.

See Tech Bulletins 002, 003, 012, 016, 017, 020, 024, 026, 030, 033, 034, 036, 074, 077, 083 and 090 for additional information.

All Q.V. parts are necessary for conversions, Q.V. and F.V. parts cannot be mixed.

MATERIAL CODES (Not Part of Part Number): ABS=ABS Plastic AL=Aluminum BBBCP=Brass/Chrome Plated CM=Chrome-moly FCM=Forged Chrome-moly
FPM=Fluorocarbon (Viton®)NBR=Medium Nitrile (Buna-N) NY=Nylon PTFE=Pure Teflon® PVDF=Fluoroplastic (High Strength) S=304SS SCP=304SS/Chrome Plated
SNG=Special Blend (Buna) SS=316SS STCP=Steel/Chrome Plated STL=Steel STZP=Steel/Zinc Plated SZZ=304SS/Zamak TNM=Special High Strength

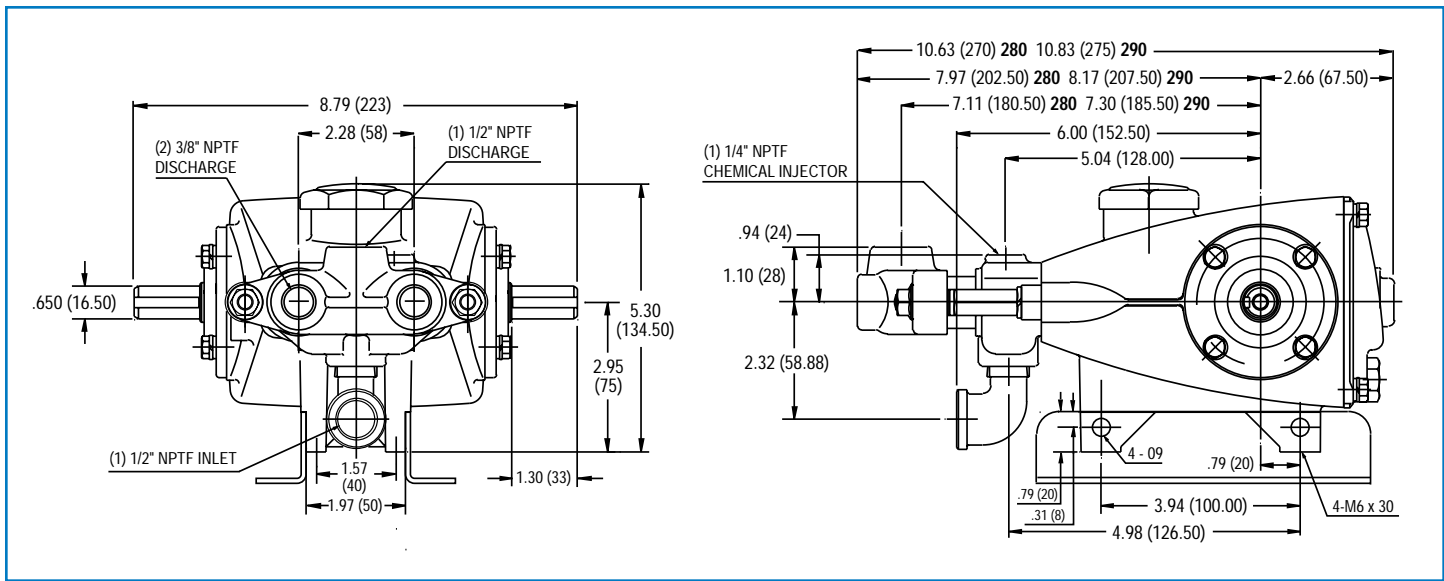

Models 280, 290

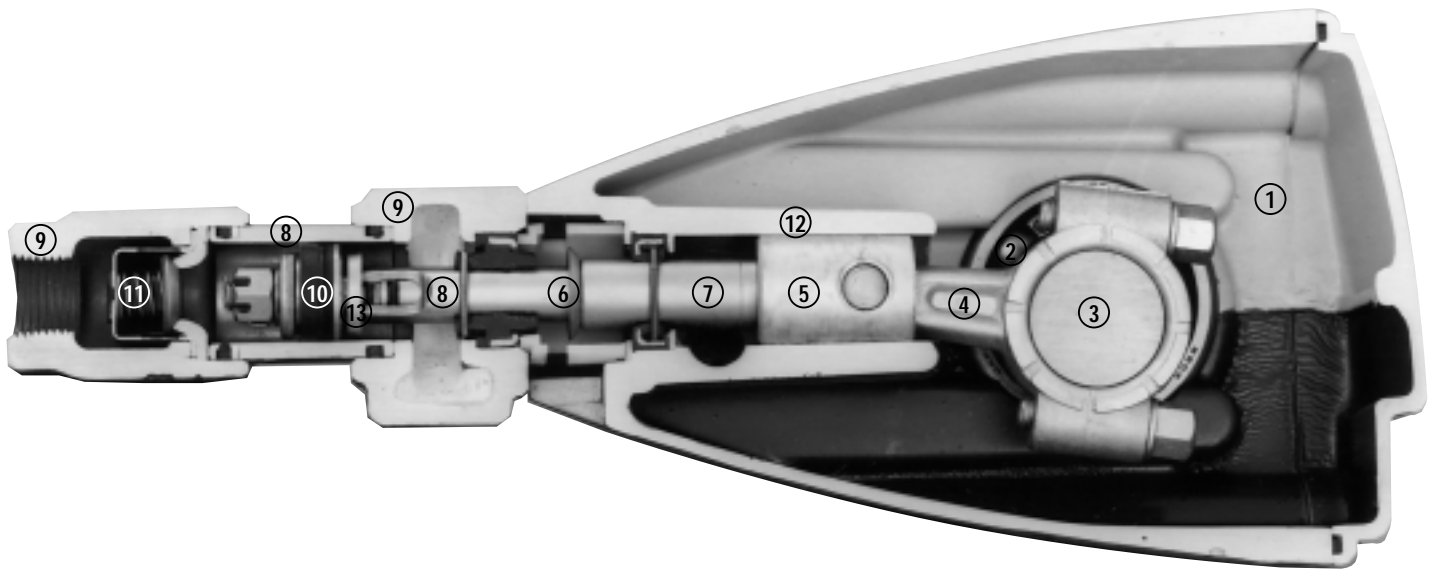

- | | | |
|--|--|--|
| <p>1 Die cast aluminum crankcase means high strength, lightweight, and excellent tolerance control.</p> <p>2 Oversized crankshaft bearings provide extended bearing life and pump performance.</p> <p>3 Chrome-moly crankshaft provides unmatched strength and surface hardness for long life.</p> <p>4 Matched high strength connecting rods noted for superior strength and bearing quality.</p> | <p>5 Special stainless steel piston rods with Zamak crossheads for longevity and corrosion resistance.</p> <p>6 The stainless steel slinger provides backup protection for the crankcase seal, keeping pumped liquids out of the crankcase.</p> <p>7 The patented stepped piston rod with hard chrome-plated stainless steel sleeve provides a durable wear surface and easy wet-end servicing.</p> <p>8 The cylinder and sleeve wear surfaces are hard chrome-plated 304 stainless steel for longer service life.</p> | <p>9 Manifolds are of high tensile strength chrome-plated brass or 316 stainless steel for special corrosion resistance.</p> <p>10 100% wet cup/seal design adds to service life by allowing pumped liquids to cool and lubricate the elastomers on both sides.</p> <p>11 304 stainless steel valves, seats, and springs provide corrosion-resistance, positive seating and long life.</p> <p>12 Crossheads are 360° supported for uncompromising alignment.</p> <p>13 Mechanically actuated inlet valves provide strong lift and easy prime.</p> |
|--|--|--|

Products described hereon are covered by one or more of the following U.S. patents 3558244, 3652188, 3809508, 3920356, 3930756 and 5035580

World Headquarters
CAT PUMPS
 1681 - 94th Lane N.E. Minneapolis, MN 55449-4324
 Phone (763) 780-5440 — FAX (763) 780-2958
 e-mail: techsupport@catpumps.com
 www.catpumps.com

International Inquiries
 FAX (763) 785-4329
 e-mail: intlsales@catpumps.com



CAT PUMPS (U.K.) LTD.
 1 Fleet Business Park, Sandy Lane, Church Crookham, Fleet
 Hampshire GU52 8BF, England
 Phone Fleet 44 1252-622031 — Fax 44 1252-626655
 e-mail: sales@catpumps.co.uk

N.V. CAT PUMPS INTERNATIONAL S.A.
 Heiveldekens 6A, 2550 Kontich, Belgium
 Phone 32-3-450.71.50 — Fax 32-3-450.71.51
 e-mail: cpi@catpumps.be www.catpumps.be

CAT PUMPS DEUTSCHLAND GmbH
 Buchwiese 2, D-65510 Idstein, Germany
 Phone 49 6126-9303 0 — Fax 49 6126-9303 33
 e-mail: catpumps@t-online.de www.catpumps.de