

25 Frame Plunger Pump

**Standard Brass
Model**

**Stainless Steel
Model**

2510

2511

FEATURES

Superior Design

- Triplex plunger design gives smoother liquid flow.
- V-Packings are completely lubricated and cooled by the liquid being pumped.
- Inlet and discharge valve assemblies interchange for easier maintenance.
- Lubricated Lo-Pressure Seals provide double protection against external leakage.
- Oil bath crankcase assures optimum lubrication.
- Close tolerance concentricity of the ceramic plunger maximizes seal life.

Quality Materials

- All stainless steel valves are heat treated and seats are roller burnished for a positive seal and extended valve life.
- Forged brass or Stainless Steel manifolds are strong and corrosion resistant.
- Special concentric, high density, polished, graphite impregnated, solid ceramic plungers are abrasion resistant and result in extended seal life.
- Specially formulated, CAT PUMP exclusive, V-Packings offer unmatched performance and seal life.
- Die cast aluminum crankcase provides high strength, minimum weight and precision tolerance control.
- Chrome-moly crankshaft gives unmatched strength and surface hardness.
- Oversized crankshaft bearings with greater loading capacity mean longer bearing life.

Easy Maintenance

- Wet-end is easily serviced without entering crankcase, requiring less time and effort.
- Valve assemblies are accessible without disturbing piping, for quick service.
- Preset packings mean no packing gland adjustment is necessary, reducing maintenance costs.

CAUTION

All systems require both a primary pressure regulating device (i.e., regulator, unloader) and a secondary pressure safety relief device (i.e., pop-off valve, safety valve). Failure to install such relief devices could result in personal injury or damage to the pump or to system components. CAT PUMPS does not assume any liability or responsibility for the operation of a customer's high pressure system.

SPECIFICATIONS

U.S. Measure

Metric Measure

MODEL 2510

Flow20 GPM (76 L/M)
Pressure Range100 to 2000 PSI (7 to 140 BAR)

MODEL 2511

Flow20 GPM (76 L/M)
Pressure Range100 to 1500 PSI (7 to 105 BAR)

COMMON SPECIFICATIONS

RPM1450 RPM (1450 RPM)
Inlet Pressure RangeFlooded to 70 PSI (Flooded to 4.9 BAR)
Bore0.984" (25 mm)
Stroke1.516" (38.5 mm)
Crankcase Capacity84 oz. (2.5 L)
Maximum Liquid Temperature140°F (60°C)
Inlet Ports (2).....1-1/4" NPTF (1-1/4" NPTF)
Discharge Ports (2)3/4" NPTF (3/4" NPTF)
Pulley Mounting.....Either Side (Either Side)
Shaft Diameter.....1.181" (30 mm)
Weight (2510).....79 lbs. (36 kg)
(2511)75 lbs. (34 kg)
Dimensions20.16 x 15.04 x 8.7" (512 x 382 x 220 mm)

HORSEPOWER REQUIREMENTS

MODEL	FLOW		PRESSURE					RPM
			PSI 1000	PSI 1200	PSI 1500	PSI 1800	PSI 2000	
	U.S. GPM	L/M	BAR 70	BAR 85	BAR 105	BAR 125	BAR 140	
2510	20	76	13.7	16.5	20.6	24.7	27.5	1450
	18	68	12.3	14.8	18.5	22.2	24.7	1305
	15	57	10.3	12.4	15.4	18.5	20.6	1088
2511	20	76	13.7	16.5	20.6	N/A	N/A	1450
	18	68	12.3	14.8	18.5	N/A	N/A	1305
	15	57	10.3	12.4	15.4	N/A	N/A	1088

DETERMINING THE PUMP R.P.M. $\frac{\text{Rated G.P.M.}}{\text{Rated R.P.M.}}$ = $\frac{\text{"Desired" G.P.M.}}{\text{"Desired" R.P.M.}}$

DETERMINING THE REQUIRED H.P. $\frac{\text{GPM} \times \text{PSI}}{1460}$ = Electric Brake H. P. Required

DETERMINING MOTOR PULLEY SIZE $\frac{\text{Motor Pulley O.D.}}{\text{Pump R.P.M.}}$ = $\frac{\text{Pump Pulley O.D.}}{\text{Motor R.P.M.}}$

See complete Drive Packages [Incls: Pulleys, Belts, Hubs, Key] Tech Bulletin 003.
Refer to pump Service Manual for repair procedure and additional technical information.

"Customer confidence is our greatest asset"

PARTS LIST

ITEM	PART NUMBER		DESCRIPTION	QTY	
● 2	990036	2510 MATL STL	990036 STL	Key (M8x7x40)	1 ●
5	92508	STZP	118824 S	Screw, HHC Sems (M8x25)	8
8	27773	AL	27773 AL	Cover, Bearing	2
10	27772	NBR	27772 NBR	O-Ring, Bearing Cover - 70D	2
11	27771	NBR	27771 NBR	Seal, Oil, Crankshaft - 70D	2
15	26512	STL	26512 STL	Bearing, Ball	2
20	48613	TNM	48613 TNM	Rod, Connecting Assembly	3
21	48533	STZP	48533 STZP	Washer, Locking	3
25	48704	FCM	48704 FCM	Crankshaft, Dual-End	1
31	828710		828710	Protector, Oil Cap	1
32	43211	ABS	43211 ABS	Cap, Oil Filler	1
33	14177	NBR	14177 NBR	O-Ring, Oil Filler Cap - 70D	1
38	11338	NBR	11338 NBR	O-Ring, Dip Stick - 70D	1
39	27769	ABS	27769 ABS	Dip Stick	1
40	92508	STZP	118824 S	Screw, HHC Sems (M8x25)	8
48	25625	STCP	25625 STCP	Plug, Drain (1/4"x19BSP)	1
49	23170	NBR	23170 NBR	O-Ring, Drain Plug - 70D	1
50	27768	AL	27768 AL	Cover, Rear	1
51	27767	NBR	27767 NBR	O-Ring, Rear Cover - 70D	1
● 53	27762	AL	27762 AL	Crankcase w/Guide Pins	1 ●
54	27488	S	27488 S	Pin, Guide	2
56	27790	PE	27790 PE	Pan, Oil	1
59	92519	STZP	92538 S	Screw, HHC Sems (M6x16)	2
64	27784	CM	27784 CM	Pin, Crosshead	3
65	‡ 48592	SSHS	48592 SSHS	Rod, Plunger	3
70	27785	NBR	27785 NBR	Seal, Crankcase Oil - 70D	3
75	110669	S	110669 S	Slinger, Barrier	3
88	110670	S	110670 S	Washer, Keyhole	3
90	48535	CC	48535 CC	Plunger, Ceramic (M25x100)	3
95	48534	STZP	48679 SS	Stud, Plunger Retainer (M7x88)	3
96	20184	PTFE	20184 PTFE	Back-up-Ring, Plunger Retainer	3
97	14190	NBR	14190 NBR	O-Ring, Plunger Retainer - 70D	3
	14161	FPM	14161 FPM	O-Ring, Plunger Retainer - 70D	3
98	44069	SSL	44069 SSL	Gasket, Plunger Retainer	3
99	43946	BB	44068 SSL	Retainer, Plunger	3
100	110672	NY	110672 NY	Retainer, LPS, Front	3
	111116	NY	111116 NY	Retainer, LPS, Rear	3
101	48487		48487	Wick, Long Tab	3
106	44086	NBR	44086 NBR	Seal, LPS w/SS-Spg	3
	45846	FPM	45846 FPM	Seal, LPS w/SS-Spg	3
107	48537	BB	48668 SS	Washer, LPS	3
● 110	48536	BBCP	48667 SS	Manifold, Inlet	1 ●
112	11379	NBR	11379 NBR	O-Ring, Inlet Manifold - 70D	3
	14183	FPM	14183 FPM	O-Ring, Inlet Manifold - 70D	3
117	48542	STZP	88398 S	Screw, HSH (M12x40)	4
126	48538	BB	48669 SS	Adapter, Female	3
127	44610	STG*	44610 STG*	V-Packing	6
128	48539	BB	113025 SS	Adapter, Male	3
141	48541	S	48672 SS	Spring, Coil	18
142	48550	BB	48670 SS	Spacer w/Coil Springs	3
155	17629	NBR	17629 NBR	O-Ring, Spacer-Rear - 80D	3
	14183	FPM	14183 FPM	O-Ring, Spacer-Rear - 70D	3
156	28243	PTFE	28243 PTFE	Back-up-Ring, Spacer-Rear	3
158	28243	PTFE	28243 PTFE	Back-up-Ring, Spacer-Front	3
159	17629	NBR	17629 NBR	O-Ring, Spacer-Front - 80D	3
	14183	FPM	14183 FPM	O-Ring, Spacer-Front - 70D	3
162	48363	D	48363 D	Back-up-Ring, Seat	6
163	26142	NBR	26142 NBR	O-Ring, Seat	6
	14330	FPM	14330 FPM	O-Ring, Seat - 70D	6
164	48544	SS	48676 SSL	Seat	6
166	45839	SSL	45839 SSL	Valve	6
167	45840	SS	45840 SS	Spring	6
168	110682	PVDF	110682 PVDF	Retainer, Spring	6
170	44794	SS	44794 SS	Washer, Spring Retainer	6
171	48546	SS	48689 SS	Spring, Coil	6
172	17667	NBR	17667 NBR	O-Ring, Valve Plug - 80D	6
	11745	FPM	11745 FPM	O-Ring, Valve Plug - 70D	6
174	120693	BBCP	811452 SS	Plug, Valve w/O-Ring	6
● 185	48543	BBCP	48674 SS	Manifold, Discharge	1 ●
188	48548	STZP	88399 S	Screw, HSH (M12x80)	6
250	26516	STCP	26516 STCP	Protector, Shaft	1
260	30614	STZP	30614 STZP	Rail, Angle Assy (Incls: 27808, 30902, 30908, 30911, 30930)	1
● 269	30206	F	30206 F	Pulley (10") [See Drive Packages, Tech Bulletin 003]	1 ●
● 270	30059	STL	30059 STL	Hub, "H", M30 (Keyway M8) [See Drive Packages, Tech Bulletin 003]	1 ●
● 279	30278	STZP	30278 STZP	Oilers (1 oz.)	3 ●
281	30967		30967	Glass, Oiler	3
282	10069	NBR	10069 NBR	Gasket, Oiler	3

EXPLODED VIEW

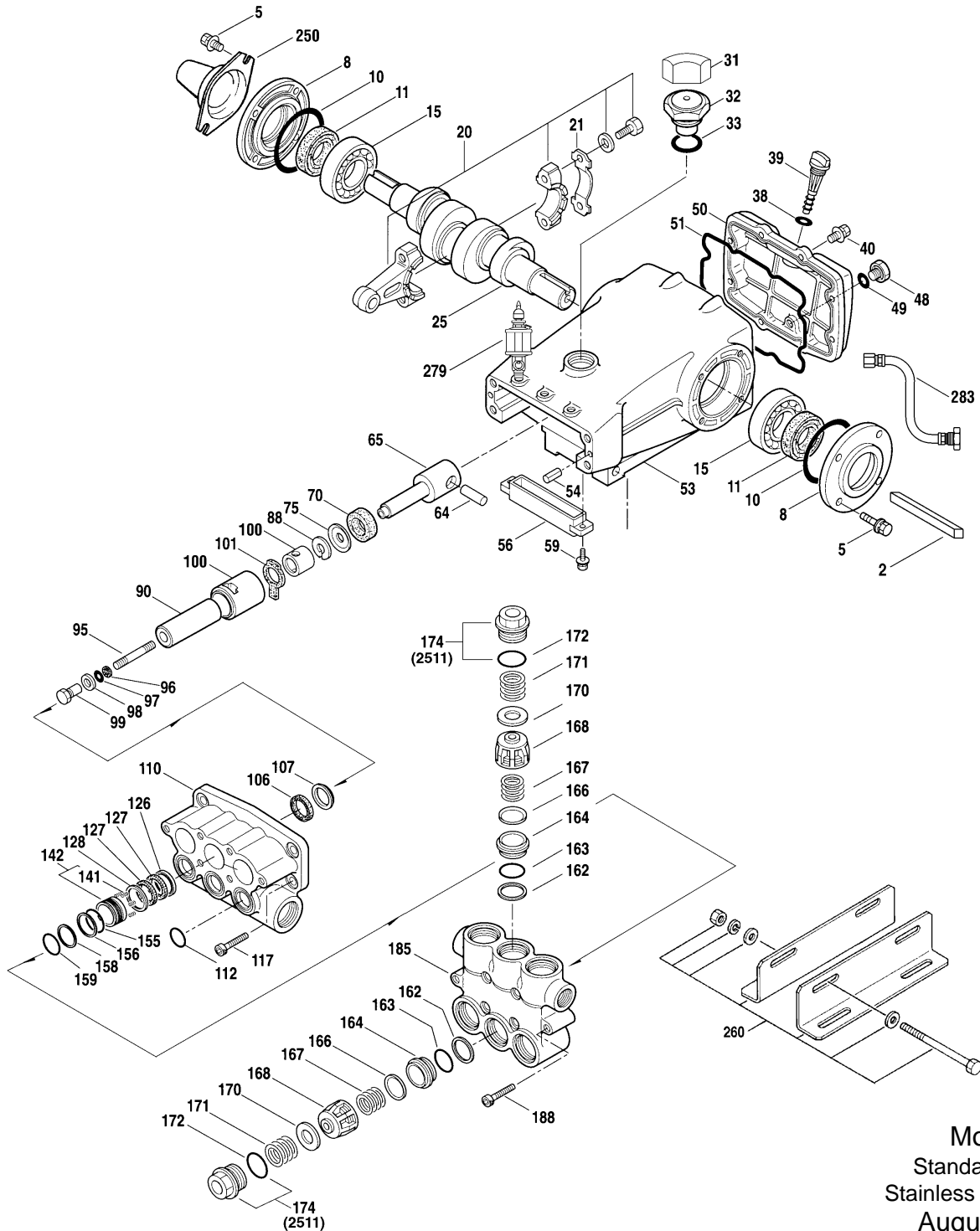

Models
 Standard - 2510
 Stainless Steel - 2511
 August 2001

	2510	MATL	2511	MATL			
●	283	34334	34334		Kit, Oil Drain	1 ●	
●	290	6104	6104		Gasket, Liquid (1 oz.)	1 ●	
●	299	816747	BBCP	816785	SS	Head, Complete	1 ●
	300	31280	<i>NBR*</i>	31280	<i>NBR*</i>	Kit, Seal (Incls: 97, 106, 112, 127, 155, 156, 158, 159)	1
	310	31380	<i>FPM*</i>	31380	<i>FPM*</i>	Kit, Seal (Incls: 97, 106, 112, 127, 155, 156, 158, 159)	1
		31285	NBR	31270	NBR	Kit, Valve (Incls: 162, 163, 164, 166, 167, 168, 170, 172)	2
		31385	FPM	31275	FPM	Kit, Valve (Incls: 162, 163, 164, 166, 167, 168, 170, 172)	2
●	—	714500	SS	714500	SS	C.A.T. (For R.O. or Industrial Applications)	1 ●
●	—	714505	SS	714500	SS	Adapter (2 per C.A.T.) (See Data Sheet for complete selection)	2 ●

● Industrial discount. *Italics are optional items.* **C.A.T. highly recommended for pressurized inlet, R.O. and Industrial applications.**

*Review material codes for individual items (STG generally may be used as alternate).

See Tech Bulletins 003, 024, 035, 036, 043, 074, 077, 083 and 085 for additional information. ‡ Production parts 304SS, replacement parts are 316SS.
 MATERIAL CODES (Not Part of Part Number): ABS=ABS Plastic AL=Aluminum BB=Brass BBCP=Brass/Chrome Plated CC=Ceramic CM=Chrome-moly D=Delrin®
 F=Cast Iron FCM=Forged Chrome-moly FPM=Fluorocarbon (Viton®) NBR=Medium Nitrile (Buna-N) NY=Nylon PE=Polyethylene PTFE=Pure Teflon®
 PVDF=Fluoroplastic (High Strength) S=304SS SS=316SS SSL=316SS/Low Carbon SSHS=316SS/High Strength STCP=Steel/Chrome Plated
 STG=Special Blend (Teflon®) White STL=Steel STZP=Steel/Zinc Plated TNM=Special High Strength

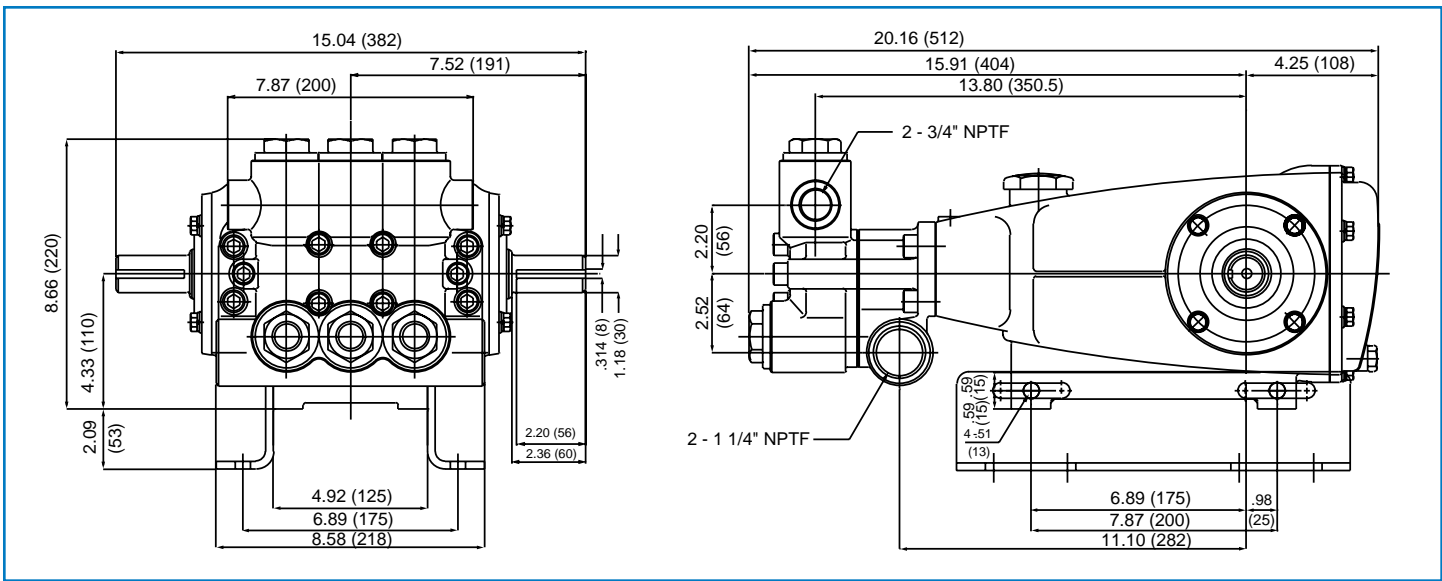

Models 2510, 2511

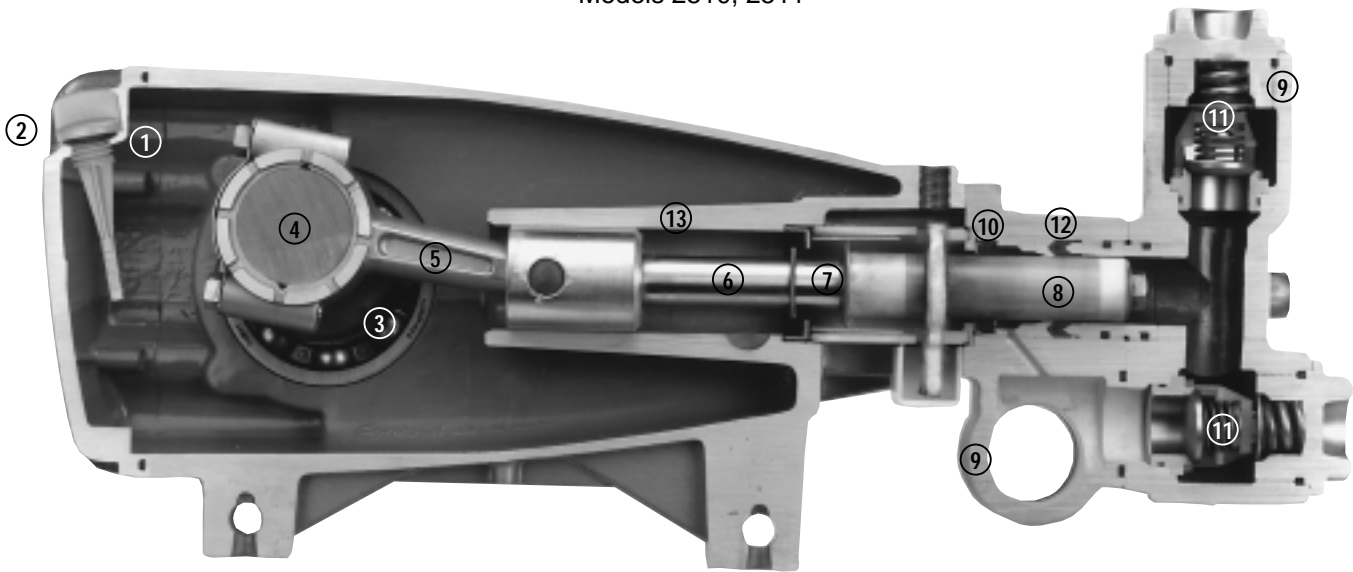

- 1 Die cast aluminum **crankcase** means high strength, light weight, and excellent tolerance control.
- 2 **Dipstick** offers top access for easy oil level check.
- 3 Oversized crankshaft **bearings** provide extended bearing life and pump performance.
- 4 Chrome-moly **crankshaft** provides unmatched strength and surface hardness for long life.
- 5 Matched oversized high strength **connecting rods** are noted for superior strength and bearing quality.
- 6 Special stainless steel **plunger rods** with high strength crossheads for longevity and corrosion resistance.
- 7 The stainless steel **slinger** provides back-up protection for the crankcase seal, keeping pumped liquids out of the crankcase.
- 8 Special concentric, high density, polished, graphite impregnated, solid ceramic **plungers** are abrasion resistant and result in extended seal life.
- 9 **Manifolds** are a high strength forged brass or stainless steel for long-term, continuous duty.
- 10 100% **wet seal** design adds to service life by allowing pumped liquids to cool and lubricate on both sides of seals.
- 11 Stainless steel **valves, seats and springs** provide corrosion-resistance, positive seating and long life.
- 12 Specially formulated, CAT PUMP exclusive, **V-Packings** offer unmatched performance and seal life.
- 13 **Crossheads** are 360° supported for uncompromising alignment.

Products described hereon are covered by one or more of the following U.S. patents 3558244, 3652188, 3809508, 3920356, 3930756 and 5035580

World Headquarters
CAT PUMPS
 1681 - 94th Lane N.E. Minneapolis, MN 55449-4324
 Phone (763) 780-5440 — FAX (763) 780-2958
 e-mail: sales@catpumps.com
 www.catpumps.com

International Inquiries
 FAX (763) 785-4329
 e-mail: intlsales@catpumps.com



CAT PUMPS (U.K.) LTD.
 1 Fleet Business Park, Sandy Lane, Church Crookham, Fleet
 Hampshire GU52 8BF, England
 Phone Fleet 44 1252-622031 — Fax 44 1252-626655
 e-mail: sales@catpumps.co.uk

N.V. CAT PUMPS INTERNATIONAL S.A.
 Heiveldekens 6A, 2550 Kontich, Belgium
 Phone 32-3-450.71.50 — Fax 32-3-450.71.51
 e-mail: cpi@catpumps.be www.catpumps.be

CAT PUMPS DEUTSCHLAND GmbH
 Buchwiese 2, D-65510 Idstein, Germany
 Phone 49 6126-9303 0 — Fax 49 6126-9303 33
 e-mail: catpumps@t-online.de www.catpumps.de