

# EnviroSpec

2011

- ▶ CLEANING CHEMICALS
- ▶ PRESSURE WASHERS
- ▶ HOOD CLEANERS
- ▶ CUSTOM BUILDS
- ▶ REPAIR PARTS
- ▶ ACCESSORIES

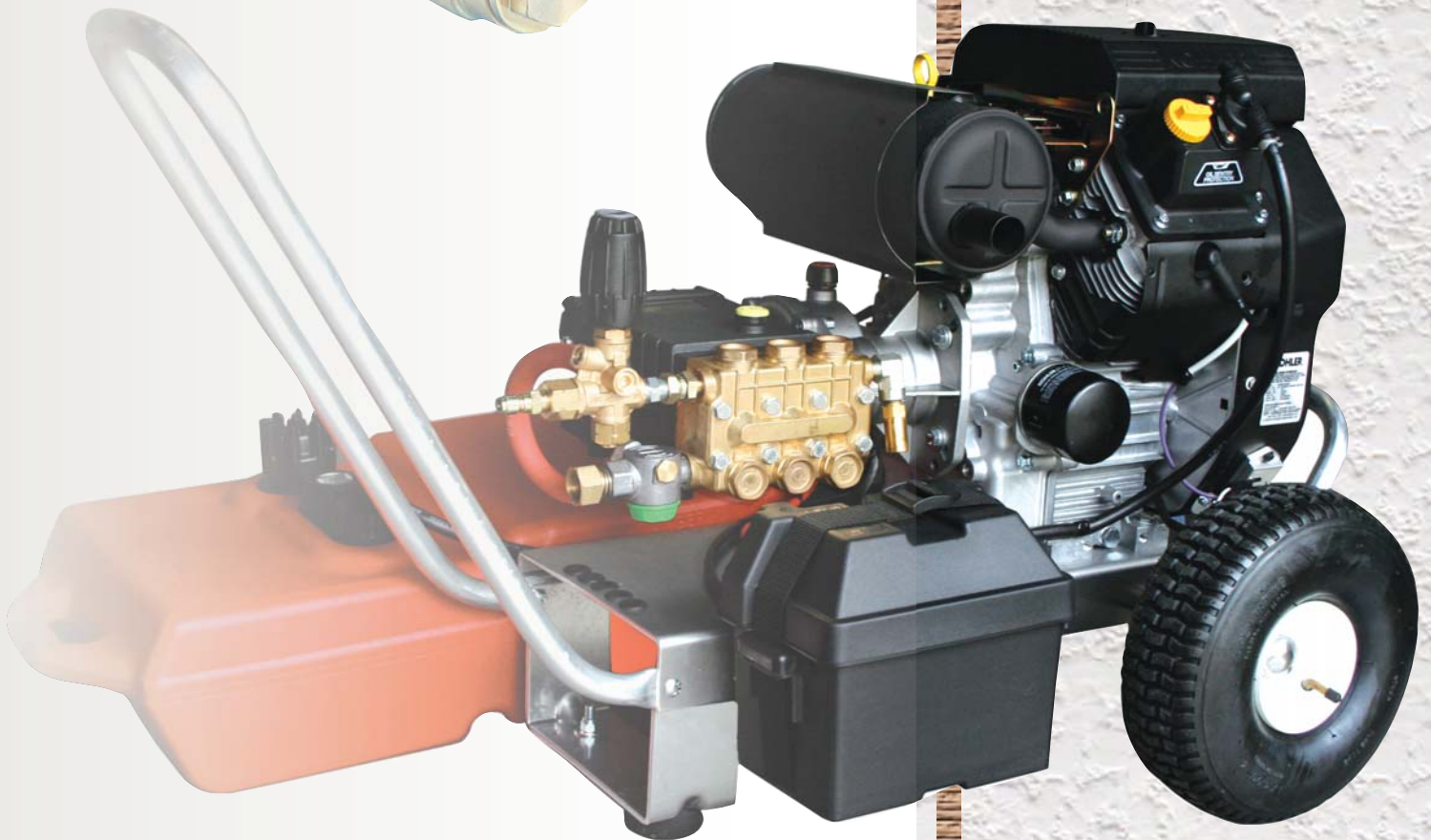
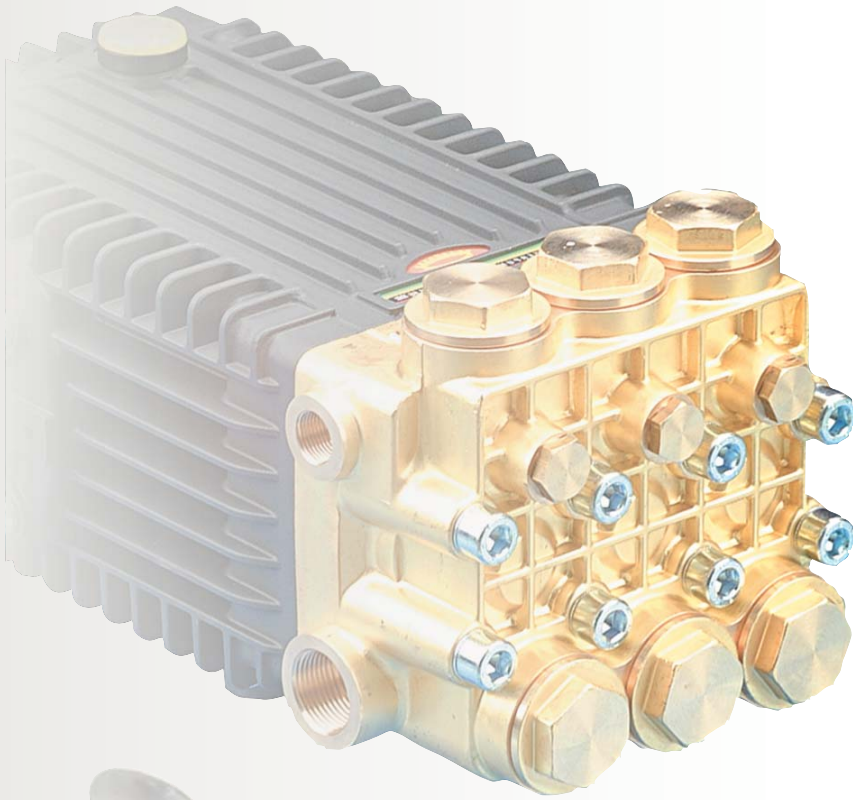

1-800-346-4876





## Who is responsible?

It is the  
**CONSUMERS RESPONSIBILITY**  
 to provide the  
**CUSTOMER SERVICE REP**  
 with the  
**CORRECT PART NUMBER**

Remember, if you don't know what you want, the best we can do is guess right along with you. We will do everything humanly possible to help you when you have a question - but you can not hold us responsible if you ask for our help and we make a mistake. With our intense and constant training programs we feel our Customer Service Reps know as much or more about our industry than do those of our competition. However, keep in mind that YOU are the PROFESSIONAL and you should know your equipment better than anyone. If you do need assistance and would like to talk directly to our Technical Service Advisor or the Manufacturer of a particular item before ordering, please ask your Customer Service Rep for their extension or phone number.

**Did you know...**  
**one female cat**  
**and her offspring**  
**can produce**  
**370,000 CATS**  
**in 7 years?**  
*please*  
**Spay/Neuter**

## SALES POLICIES

### DISCLAIMER

Some of the pictures within this catalog are for illustration purposes only. Be sure and ask your sales representative if the item in question is represented by the picture herein. **EnviroSpec reserves the right to limit quantities of any item in this catalog. Prices are subject to change without notice.** It is the purchasers responsibility to order by part number and to ask the sales representative to read back the order along with the current pricing and availability. This catalog is for the sole intent to sell to industry professionals only and possession of this catalog or any marketing material from EnviroSpec does not necessarily mean that we will be able to sell to you.

### RESTOCKING CHARGE

Any item that is ordered incorrectly and is returned to EnviroSpec within 30 days of purchase and in a "not used" or "not installed" condition with it's box in the same condition and where the credit is to remain on the customers account for future purchases will be credited at full purchase price less shipping. If the item in question is to be credited back to the customers credit card it will be done so less 20%. If payment was made by check we will hold a credit in the customers account. Any credit held in a customers account must be used in it's entirety when the customer places his/her next order. Remember, items must be returned pre-paid to EnviroSpec and must be in unused condition and showing no signs of mounting and/or installation and if the item has it's own re-sell container/box that also must not show any signs of being damaged or crushed.

### RETURNS

Items ordered and not returned within **30 days** from the original order date or items ordered that are not in our catalog **ARE NOT** returnable. If you are ordering an item that is not in our catalog and would like to talk to the manufacturer first we will gladly give you their phone number. Just ask!

**CHEMICALS, EQUIPMENT, VACU-BOOMS  
 & ENGINES ARE NOT RETURNABLE**

**Shipping is never refundable.**

### WARRANTY

All items sold in this catalog are **NEW** and not refurbished or used components. EnviroSpec does not warranty any item in this catalog except those that are manufactured by EnviroSpec. All warranties are presented to the buyer by the original manufacturer and must be returned, pre-paid, to EnviroSpec for evaluation and adjustments. All returned items must be accompanied by an "RGA" (Returned Goods Authorization) which EnviroSpec will provide to you. EnviroSpec **WILL NOT** send out replacement item(s) on a "no-charge" basis while EnviroSpec or the manufacturer is evaluating a returned item. If you need an immediate replacement you will have to purchase said replacement. However, you must understand that all items are covered by a "repair" or "replace" warranty and you could wind up with two of the same items. *We like to call them "spares".*

### EQUIPMENT PURCHASES

If you purchase equipment from EnviroSpec you will do so under the same terms and conditions as a distributor of our products. Those terms and conditions are as follows: We **DO NOT** provide any labor warranty but only a warranty on parts and components that go into the make-up of the final product when they are returned to us pre-paid.

Also, you **MUST UNDERSTAND** that in shipping large equipment - nuts, bolts, components, etc. may work loose and adjustments may have to be made prior to selling or using the equipment.

If you do not feel that you have the ability to work on and/or repair the equipment you want to purchase we encourage you to purchase locally.

### RECEIVING YOUR PACKAGES

**DO NOT SIGN FOR ANYTHING** that looks like it has been damaged! Refuse it so we can handle the UPS/Shipping Claim. **IF YOU DO SIGN FOR IT** and there is a problem **WE CAN NOT HELP YOU**. At that point you will have to contact the shipping company for adjustments. If UPS leaves a package without your signature and there are damages call your local UPS and have them pick up the package. Do not throw away any packaging on damaged goods. Save for UPS Inspection.

**SEE THE INDUSTRY'S MOST POPULAR PUMPS ON PG. 77**





# CHARITIES

EnviroSpec donates 100% of the after tax profits from our Chemical Sales to the Shriners Hospital for Children in Tampa, FL. and to Suzies Friends No-Kill Animal Shelter/Sanctuary located in Homerville, GA.

In 2002 John & Shelley Allison, owners of EnviroSpec, traveled the highways and by-ways of their local communities and began picking up and helping abandoned, hungry and sick animals. That initial labor of love has grown to become a major commitment in their lives.

In the last two years alone they have trapped and spayed/neutered over 500 cats & dogs. On the weekends they take animals to PetsMart where they find homes for the ones who have been or can be socialized. Those who dont find homes are returned to their colonies and every morning at 6:15 and every afternoon at 4:45, 7-days a week, John & Shelley head out in their golf cart, better known as Suzies Friends Meals on Wheels, to feed and monitor the colonies.

Back at their No-Kill Shelter/Sanctuary in Homerville the employees of EnviroSpec start and end their day by providing the animals there with same attention and care as those in the colonies receive.

Please consider helping a Shelter or Rescue in your area. Its a great feeling knowing that you have helped an abandoned, helpless & hungry animal who would otherwise never have had a chance. And never forget the tireless work of helping children in communities throughout the Nation that is silently performed by Shriners everywhere.

And please Spay/Neuter your pets. Remember, an unborn animal will never die a lonely death in an animal shelter.



Suzie





## Minimum Orders and Free Freight Program

Our minimum order is \$50.00. However, if you are unable to meet the \$50.00 minimum order a \$5.00 handling fee will be included in the price.

**Free Freight:** Free Freight only applies to orders shipped to the lower 48 United States. At the bottom of each page you will see our freight policy for all the items found on that page. **Web or FAX Orders of \$50.00** or more qualify for **FREE FREIGHT** as long as the items are identified in this catalog as free freight eligible. **Call-in orders of \$200.00** or more qualify for **FREE FREIGHT** as long as the items are identified in this catalog as free freight eligible. There will be an extra charge for priority shipping or additional services not normally covered in standard shipping such as 'lift-gate' services. We reserve the right to ship 'cheapest way' if we are paying the freight.

## How to Return an Item

Nobody wants to keep something that they don't want or need.

When this occurs - all you need to do is call 1-800-346-4876 and request a return goods authorization number (RGA). When you obtain this authorization number follow these instructions.

Ship your **PRE-PAID** box to:

**EnviroSpec  
751 MLK Hwy  
Homerville, GA 31634**



1. Package the box well. Items inside the box should not move when shaken. Many of the items that you purchase are very heavy and become penetrating projectiles in an unsecured box. Quite often we receive a box with a hole in its side and nothing in the box.
2. Place the RGA number on the outside of the box as shown.
3. Address the box as shown
4. Insure the box and make sure you hang on to your tracking number.

**Don't forget the  
RGA NUMBER**

### **DO NOT FORGET TO INSURE YOUR PACKAGE!**

Things get lost and/or damaged in shipping. **If they try and deliver a package that shows evidence of being damaged we will refuse the package.** At this point you will have to contact your shipper and handle a claim through them. If you did not insure the package chances are you will not have a satisfactory outcome.





# TABLE OF CONTENTS

**See Pages 83-94 for  
DETERGENTS & ACIDS**

<b>Suzie's Friends</b> 95	Filters, Water 34	Long Wands 36	Sewer Nozzle 39
Ball Type Noz Holder 44	Fittings, Plumming 29	Loom, Wire 59	Shield for Turbos 45
Ball Valves 30	Fittings, ShurFlo 32	Mixer, Chemical 28	Shower Noz Holder 44
Base Plate, PW 58	Float Valve/Tank 19	Motor, Burner 52	ShurFlo Pumps 32
Batter Box 58	Flow Switch 51	Mounting Block, Fuel 54	Siphon Pump 40
Battery Terminals 58	Foamers 33	MTM Turbos 46	Sirocco 15
Beckett Burners 51	Frame, Dual Pumper 59	Nozzle Clean-out Tool 43	Site Glass for Pumps 61
Belt Clip Noz Holder 44	Frames, PW 58	Nozzle Gauge, Burner 54	Sludge Sucker 26
Blow-out Valve 54	Fuel Filter, Burner 52	Nozzle Holders 44	Soap Nozzles 43
Boot, Nozzle 44	Fuel Line 57	Nozzle, Burner 51	Solenoid, Eng Starter 57
Brushes 40	Fuel Pump 52	Nozzle, Cone, Lo-Press 31	Solenoid, Fuel 52
Burner Diagnostic 53	Fuel Solenoid 52	Nozzle, Hi-Lo 43	Soot Remover 54
Burner Insulation 54	Funnel for Drums 40	Nozzle, Lo-Press 43	Spark Plugs 57
Burner Motor 52	Fuses & Lights 54	Nozzle, Push-Pull 43	Sparflex Lance 35
Burner Relay 53	Gas Cap, Honda 58	Nozzle, Thruster 45	Stiletto Nozzle 46
Burner Tester 54	Gate Valve 30	Nozzle, Performance 36	Switch, Flow 51
Burners & Supplies 51-54	Gauge Port 61	Nozzles, Pressure 41-42	Switch, Hi-Limit 51
Bushings & Pulleys 60	Gauge, Burner 54	Oil Drain Plug 57	Switch, On/Off 51
Car Wash Gun/Lance 19	Gauges, Pressure 62	Oil, Pump 61	Switch, Pressure 51
CD, Pump Rebuilding, GP 81	Gear Box/Reducer 60	On/Off Switch 51	Switch, Vac 51
Check Valve 25	Generator 53	PA Turbo Nozzle 46	Swivel, Hose Reel 39
Chem Filters 25-26	Gutter Brush 40	Packing Extractor Kit 81	Tachometer 57
Chem Line 25 & 31	Gutter Sweep 35	Packing Insertion Kit 81	Tanks, Equipment Fuel 59
Chem Metering Valve 27	Hi-Limit Switch 51	Pipe Sealant 61	Tanks, Fuel 40
Chemical Hose 39	Hose Barbs, Poly 31	Pistons, GP 62	Tape, Electrical 61
Chemical Induction System 16	Hose Hold Down Clips 59	Pressure Gauge 62	Tape, Teflon 61
Chemical Injectors 25-26	Hose Reel Swivel 39	Pressure Gauge Port 61	Teflon Tape 61
Chemical Pumps 32	Hose Reels 37	Pressure Switch 51	Telescoping Wand 36
Chlorine Pumper 14	Hose Whips 19	Pressure Test Equipment 62	Tester, Burner 54
Clamps, Hose 59	Hose, Fire 34	Pressure Washers 1-13	Tester, Pump Head 62
CLAWS Compliance 28	Hose, Hi-Pressure 38	Puller, Pulley 60	Testers, Pressure 62
Clips, Hose Hold Down 59	Hose, Jumper 38	Pulley Puller 60	Thermal Dump Valve 27
Clothing 47-50	Hose, Sewer 39	Pulleys & Bushings 60	Thermostats 51
Clutch, 12V Engine 60	Hour Meter 57	Pump Dip Sticks 61	Thread Locker 61
Coil Blow-out 54	Hudson Float Valve 19	Pump Head Tester 62	Throttle Cable 57
Coils, Burner 54	Hydro-Broom 18	Pump Kits, GP 62, 75, 76, 81	Thruster Nozzle 45
Concrete Cleaners 17-18	Ignitor, Burner 52	Pump Kits, UDOR 64	Tires 58
Connector, Garden Hose 34	Insulation, Burner 54	Pump Oil 61	Transformer, Burner 52
Cyclone 14	Jumper Hose 38	Pump Saver 61	Trigger Guns 19-20
Diagnostic Center, Burner 53	Keeper Noz Holder 44	Pump Site Glass 61	Trombone Noz Holder 44
Diaphragm Pumps 63	Key Switch, Eng 58	Pump, Burner Fuel 52	Trigger Gun, Chem, Lo-Press 31
Dip Sick, Pump 61	Key-way Stock 57	Pump Repair Video 81	Turbo Filter 46
Dirt Killer Turbos 45	Kits, A-R 82	Pumps, A-R 82	Turbo Nozzles 45
Drill Mixer 28	Kits, GP 62, 75, 76, 81	Pumps, GP Jetting 79-80	Turbo Shields 45
Drum Accessories 40	Kits, UDOR 64	Pumps, GP Pressure 69-74, 77	Twist-Fast Noz Holder 44
Drum Funnel 40	Lafferty Foamers 33	Pumps, UDOR Diaphragm 64	Unloader By-pass Hose 22
Dual Lance 36	Lance Caddy 44	Pumps, UDOR Pressure 63, 65-68	Unloader Hi-Spike Hose 22
Easy Start Valve 27	Lance Grips 35	Racor Filter 52	Unloader Mounting Block 22
Educational 81	Lance, Aluminum 35	Rain Gear 47-50	Unloader Valves 21-22
Engine Auto Shut-down 61	Lance, Dual 35	Rebuilding Video 81	Vac Switch 51
Engine Throttle Down 59	Lance, Flex 35	Relay, Burner 53	Vacu-Boom 15
Engines 55-56	Lance, Pivot 35	Roof & Ice Walkers 28	Valve, Sewer Jetting 61
Exhaust Hood Swivels 27	Lance, Plated 35	Roof Cleaning Equip 28	Viper Turbo 45
Extraction Tools, Packings 81	Lance, Spray-flex 35	Rotajet Nozzle 45	Waste Water Recovery 15
Filter, Eng Fuel 57	Lance, Stainless 35	Rotomax Nozzle 45	Water Hose 39
Filter, High Pressure 46	Lid-off 40	Safety Relief Valve 27	Water Line 31
Filter, Burner Fuel 52	Lids for Drums 40	Sand Blast Equip 28	Winco Generator 53
Filters, Engine 57	Lights & Fuses 54	Sewer Jetting Valves 61	Wire Loom 59

# Prices Rolled-back

## BEGINNING MARCH 1, 2011

**YOU WILL NOTICE THAT PRICES ON  
CHEMICALS HAVE BEEN ROLLED BACK  
20-30% WHILE ALL PARTS HAVE BEEN  
ROLLED BACK 10-15%.**

# 2011 BONUS BUCKS

**Contractors can receive up to...**

# 10% CASH BACK

in the form of Bonus Bucks when they purchase from EnviroSpec. This money will accumulate and can be used to reduce the cost of items by 10% that are purchased in February & March 2012 at Mobile Wash season start-up.

This was a huge success during February 2011. Contractors made many purchases well below our actual cost. Many saved their bonus bucks for that new piece of equipment to start out the new season with while others purchased multiple pumps and/or several months supply of chemical.

You will accumulate Bonus Bucks when you purchase Chemical, Parts and Accessories found in this catalog between the months of April 2011 and January 31, 2012.

Purchases that do not qualify for Bonus Buck Accumulation are gas engines or any item powered by a gas engine or electric motor (except Shurflo Pumps), recovery systems, pressure washers, pumps, concrete cleaners & items not in our catalog. But remember - in February & March of 2012 you can pay for ANYTHING you purchase with accumulated bonus bucks.

*In other words...*

If you have \$350.00 in your bonus buck account and you want to purchase a machine that cost \$4500.00 you can use all of your bonus buck money to reduce the cost of the machine because 10% of \$4500.00 is \$450.00 dollars.

On the other hand - if you have \$350.00 in your account and your total invoice is only \$700.00 you can only use \$70.00 of your bonus bucks since that represents 10% of the total invoice. The remaining \$280.00 will stay in your bonus buck account to use at a later date.

(Taxes & freight can not be paid for with Bonus Buck money.)



# LARGO PRESSURE WASHERS

## STANDARD FEATURES

- Triplex, Oil Bath, Ceramic Pump
- Black Powder Coated Frame
- 10" Pneumatic Tubed Tires
- Painted Coil Wrapper
- 35' GFCI on 115V Units
- High Limit Over Temp Protection
- Black Pipe Heating Coil
- 50' 3/8" Quick Coupled Hose
- Industrial 1725rpm Electric Motor
- Quick Coupled Spray Tips
- Poly Fuel Tank w/ Fuel Gauge
- Gun Control
- High Pressure Detergent
- Trigger Gun w/4' Lance
- 10' power cord, no plug on 230v

## OPTIONS:

- Open Gun (Below 2000 psi)
- Time Delay Shutdown -
- Steam Combo
- 8" Draft Diverter
- Hose Reel 50' or 100'
- Water Separating Fuel Filter
- Hour Meter
- Thermostat
- 40 amp GFCI - 230V 1Ph
- 460 3-Phase
- Stainless Steel Coil Wrapper
- Optional 230/460 Volt 3Ph w/o GFCI



*There is 'red hot' and then  
there is a 'hotter hot...'*

**WHITE HOT**

**UP TO 280° ON THE MD280E**

**Complete  
Trailer Rigs  
Available  
Call!**



Model	GPM	PSI	HP	VOLT/Ph	AMPS	WEIGHT	DIMENSIONS	PRICE
<b>MD280E</b>	2.2	1250	2	115/1	20	400	26W x 36L x 42H	\$2203.35
<b>21</b>	2.2	1250	2	115/1	20	330	24W x 34L x 40H	\$2070.75
<b>35</b>	3.5	2400	5	230/1	28	415	26W x 36L x 42H	\$2687.45
<b>42</b>	4.0	2000	5	230/1	28	525	28W x 39L x 47H	\$2927.85
<b>45</b>	5.0	1500	5	230/1	28	525	28W x 39L x 47H	\$2927.85

These are the #1 Selling Specifications in the Industry!







## BELT DRIVE TOMCAT

### STANDARD FEATURES

- 4 Wheel - 10" Pneumatic Tubed Tires
- Powder Coated EHD Frames
- Sch. 80 Black Pipe Heating Coil
- Painted Coil Wrapper
- 50' 3/8" Quick Coupled Hose
- Gun Control with Dual Lance Wand
- Color Coded Spray Tips
- Belt Driven General Pump
- Low Pressure Detergent, Down Stream
- 12V DC Beckett Burner
- High Limit Over Temp Protection
- Thermal By-pass Shutdown
- Poly Diesel Tank with Fuel Gauge
- Electric Start Engine
- Front Bumper - Protects Eng. & Fuel Tank
- Powder Coated Gas Tank

May be used with mobile water tanks.  
Requires additional Plumbing and  
Inlet Filter Minimum 3/4"

#### OPTIONS:

- Steam Combo
- Hose Reel 50' or 100'
- Water Separating Fuel Filter
- Stainless Steel Coil Wrapper
- Anti Roll Brake
- Front Roll Cage
- High Pressure Chemical
- SS Float Tank
- Soap Solenoid

*Shown with optional roll cage.*

MODEL	GPM	PSI	HP	ENGINE	BURNER	WEIGHT	DIMENSIONS	PRICE
1535B	4.0	3500	13	Honda	12VDC	525	29W x 51L x 44H	\$3802.27
1540B	4.0	4000	18	Vanguard	12VDC	545	29W x 51L x 44H	\$3802.27
1553B	5.0	3000	18	Vanguard	12VDC	585	29W x 51L x 44H	\$3886.28
1555B	5.0	3500	20	Honda	12VDC	615	29W x 52L x 46H	\$4263.35

Let's all have a...  
**'MELT-DOWN'**  
**280 DEGREE**  
**EXHAUST HOOD**  
**CLEANING SYSTEM**

*There is 'red hot' and then  
there is a hotter hot...*

**WHITE HOT**  
**UP TO 280° OUTPUT**

**U-Pay Freight this Page**



Model: **MD280G**

**3.0 GPM**

**3000 PSI**

**13 HONDA**

**12VDC Burner**

**525 LBS.**

Measurements:

**29W x 51L x 44H**

**\$3280.64**

**Electronic Chemical Switching Available**



# HIGH VOLUME HEATERS

## DUAL-PASS COIL SYSTEM

**PERFORMANCE beyond your wildest imagination!**



All Include BURNER DIAGNOSTICS			
P/N	CONFIGURATION & VOLUME	ELECTRICITY REQUIRED	DELIVERED PRICE
<b>9898</b> 880,000 BTU COIL	HORIZONTAL UP TO 12 GPM	12 VOLT	<b>\$2795.00</b>
<b>9899</b> 880,000 BTU COIL	HORIZONTAL UP TO 12 GPM	120 VOLT	<b>\$2495.00</b>
<b>9817</b> 490,000 BTU COIL	VERTICAL UP TO 6 GPM	12 VOLT	<b>\$2195.00</b>
<b>9815</b> 490,000 BTU COIL	VERTICAL UP TO 6 GPM	120 VOLT	<b>\$1995.00</b>
<b>9816</b> 880,000 BTU COIL	VERTICAL UP TO 12 GPM	12 VOLT	<b>\$2495.00</b>
<b>9814</b> 880,000 BTU COIL	VERTICAL UP TO 12 GPM	120 VOLT	<b>\$2195.00</b>
<b>1-866-487-1778</b>			

*There is 'red hot' and then there is a 'hotter hot...'*

**WHITE HOT**

*...up to*

**880,000 BTU**

**U-Pay Freight this Page**





There is 'red hot' and then there is a hotter hot...

WHITE HOT

UP TO 880,000 BTU OUTPUT

# SUPER SKID

The most advanced coil design in the PRESSURE WASHER INDUSTRY

**20" DUAL PASS COIL DESIGN**



VERTICAL SYSTEM SHOWN

### System Features:

- Industrial Pumps with 5 year head warranty
- Kohler, Briggs & Honda Engines
- The largest recharging systems in the industry
- The industry's largest and most efficient heating system
- Our Special Spec Beckett 12 Volt Burners
- Allison Relays for trouble free 12 Volt Burner life
- High Volume Fuel Tanks for long, uninterrupted runs.
- Hour Meter
- Safety Pressure Relief Valve
- Hose, Gun, Lance & Nozzles included.

**WITH COMPLETE BURNER DIAGNOSTICS**

FLOW TEMP HI-LIMIT

Allison Burner Diagnostic Center

STAINLESS COIL COVER ON HORIZONTAL ADD \$150.00

PART NUMBER	ENGINE	SPEC	PRICE
<b>18V-ADC-V5635</b> VERTICAL COIL	18 HP VANGUARD	5.6 GPM 3,500 PSI	<b>\$3990.00</b>
<b>18V-ADC-H5635</b> HORIZONTAL COIL	18 HP VANGUARD	5.6 GPM 3,500 PSI	<b>\$4375.00</b>
<b>30K-SDC-H8536</b> HORIZONTAL COIL	30 HP KOHLER	8.5 GPM 3,600 PSI	<b>\$5985.00</b>
<b>30K-SDC-H1030</b> HORIZONTAL COIL	30 HP KOHLER	10.0 GPM 3,000 PSI	<b>\$5985.00</b>

For Units with 115V Generators - Call!

**U-Pay Freight this Page**

You can look all you want but there is none better than an Iron Horse and we have hundreds of professionals who beat on them everyday that can prove it!





either  
**One Operator running  
10.0 GPM @ 3,800 PSI**

or  
**One Operator running  
5.0 GPM @ 3,800 PSI**

or  
**Two Operators running  
5.0 GPM @ 3,800 PSI**

# DUAL PUMPER

*...Power in the Hands of a Few!*

**DPI038CW - \$7495.00**

**Up to 24 GPM  
Up to 4,500 PSI**

**38  
Horsepower  
KOHLER**

**YU-2140  
Unloaders**

**6,000 PSI  
Controllers**

**'No Mess'  
Oil Filter  
Replacement**

**26 Gallon  
Fuel Tank**

**Tri-Plex  
Industrial  
Pumps**

**Sealed  
Battery  
Compartment**

**Unloader  
Adjusting  
Wheel**

**Quick Change  
Lubrication  
System**

**Allison  
Engine  
Terminator**

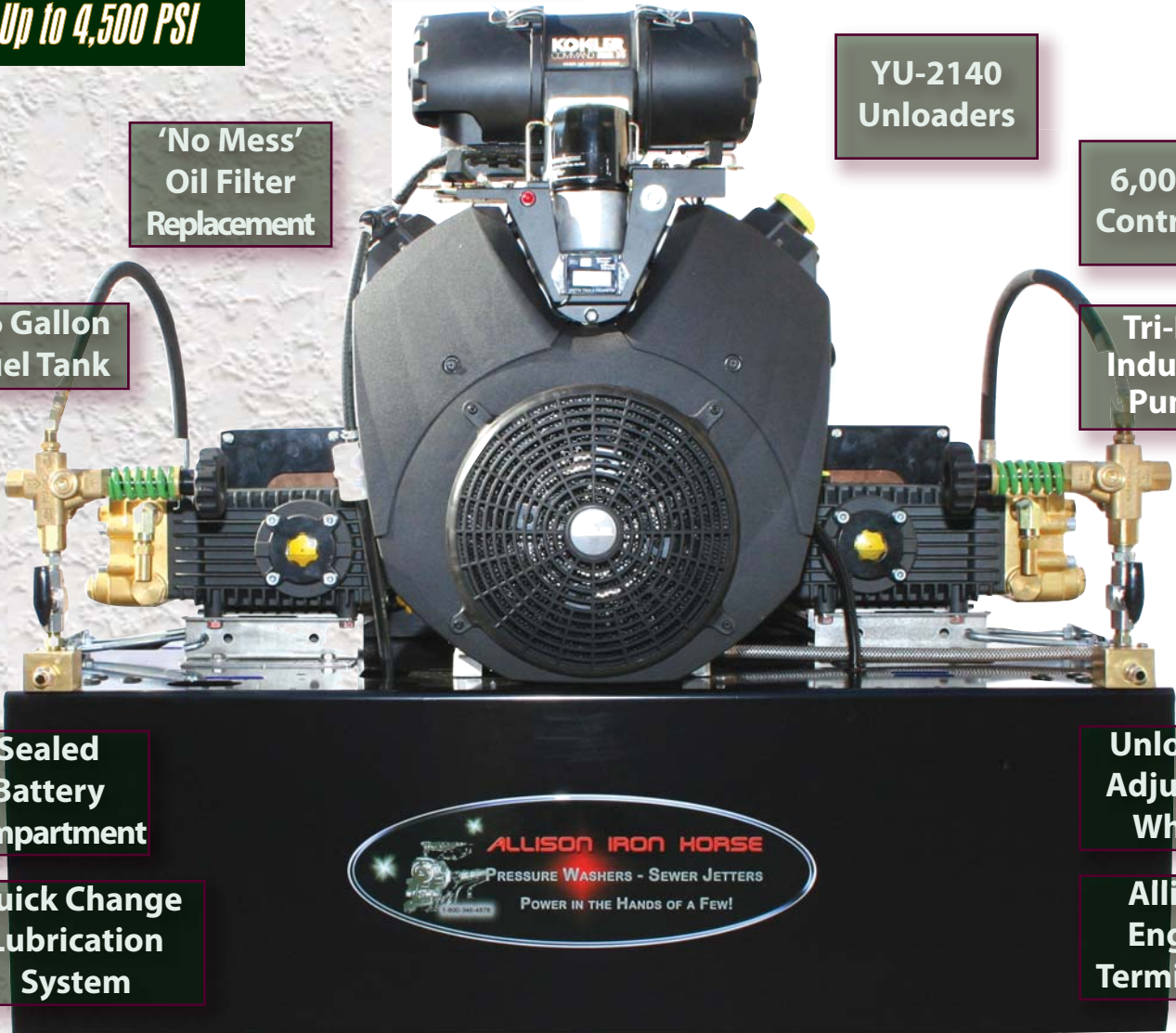



# ALLISON SLIMLINE SPACE-SAVER SUPER SKID

## Our #1 Selling Hot Water

# SUPER SKID EVER!

Features:

- 18 & 30 HP KOHLER Engines,
- Dual Battery Compartments,
- Thermostat Controlled,
- Dual-Pass Heating Coil,
- Large Volume Water Filtration,
- Allison Supper Suds Sucker Injector,
- Burner Diagnostic System,
- Beckett 12V SDC Burner,
- Racor Fuel Filter/Water Separator,
- Vibra-Loc Vibration Dampening System,



There is 'red hot' and then  
there is a 'hotter hot...'

# WHITE HOT

No-one makes a better heating system!  
No-one makes a better delivery system!  
No-one know more about what a  
contractor needs than an ex-contractor!

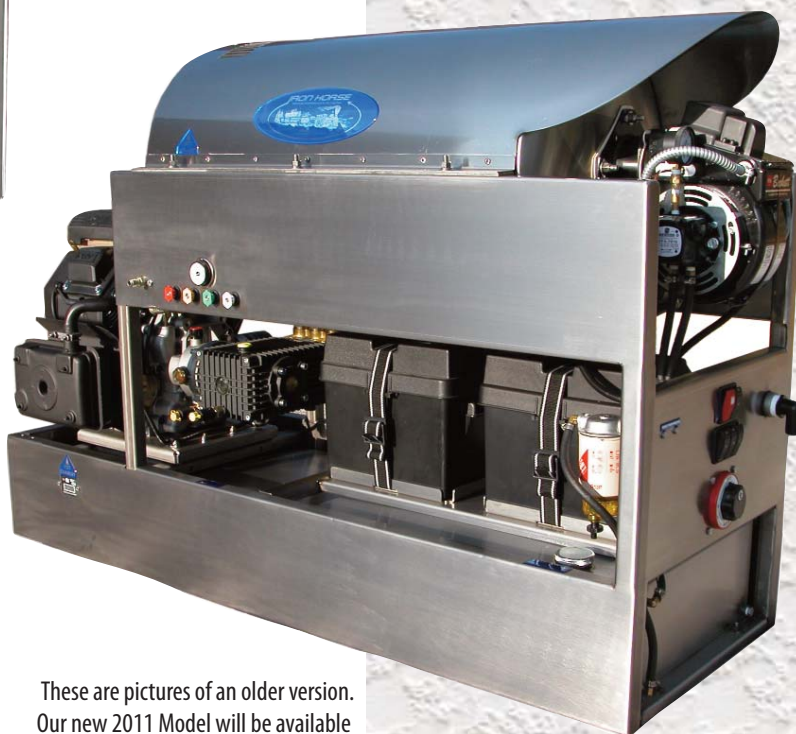

These are pictures of an older version.  
Our new 2011 Model will be available  
APRIL 10, 2011

Model	Engine	PSI	GPM	List	Contractor
5535SL	Kohler 18	3500	5.5	\$10,995.00	<b>\$5,490.00</b>
8635SL	Kohler 30	3500	8.5	\$11,995.00	<b>\$6,490.00</b>
1030SL	Kohler 30	2900	10.0	\$11,995.00	<b>\$6,490.00</b>

**U-Pay Freight this Page**





# CHEETAH

Most use a 19 lb. pump with aluminum connecting rods.

Ours is a 28 lb. pump with solid bronze connecting rods.

Expect ours to last 10 times longer

**A TRUE 3,850 PSI @ A TRUE 3,000 PSI @**  
**A TRUE 4.2 GPM @ A TRUE 5.0 GPM**

**CHEETAHS Start Quicker, Run Quieter & Last Longer**



**14 HP KOHLER**  
with 3-year warranty

**UDOR PUMP**  
 4.2 GPM @ 4000 PSI  
 5.0 GPM @ 3000 PSI

Industrial Hose Reel with Non-Marking Hose

The New Hyde 51" Pivoting Nozzles Lance

Vibration Isolators between engine and base plate

Premium 13" Wheels

Integrated Tool Tray and Nozzle Holders

Engine Shuts Down if Pump Overheats

Aren't you tired of being fooled?

For years people have been buying what they thought was a **4 GPM @ 4000 PSI PRESSURE WASHER** with a 13 HP Honda

**IMPOSSIBLE!**

First of all there is not enough power in a 13 HP engine to produce this amount of water at this psi.  
 The math is as follows:  
 GPM x PSI divided by 1100 is what is required in the way of gas engine horsepower.

**\$1490.00**

#14404 - 4.0 GPM  
 #14305 - 5.0 GPM

**U-Pay Freight this Page**



# Signature Series

**RELEASE THE TRIGGER**  
**and the engine**  
**RETURNS TO IDLE**  
**which gives you up to**  
**\$2500.00 p/y in fuel savings!**

Each System is  
CUSTOM BUILT  
in our  
PERFORMANCE SHOP  
Allow 2 weeks build, test  
and certification time.

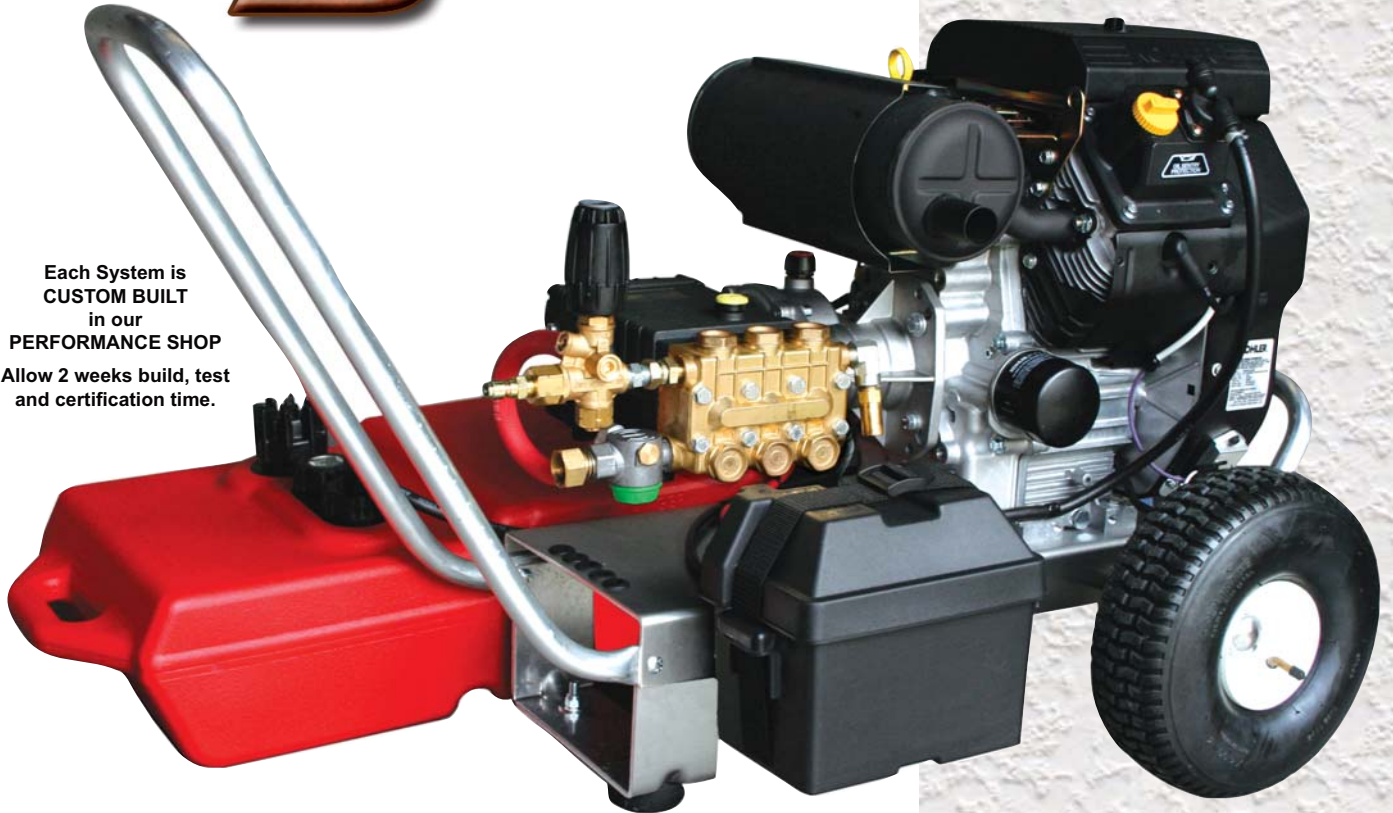

With the Signature Series we didn't just want another version of 'the same'. We wanted everyone who first sees the Signature to immediately recognize a level of excellence that they have never seen before. When you buy a pressure washer you have bought just another pressure washer. When you buy an Allison Signature you will have bought performance & functionality and you will own a system that will still be running long after most of the 'typical' pressure washers have turned back into dust.

### System Features:

- Triplex Pumps with bronze connecting rods, special roller bearings and hardened crankshaft.
- Allison Engine Terminator shuts down the engine should the pump overheat.
- Kohler Engine, Electric Start & Electronic Idle Down
- The largest recharging systems in the industry makes this system 'hot water ready'. Just hook it to a heater.
- Allison Soft Core, Unloading System with the lowest 'cycling threshold' in the industry.
- Quick Change Oil System on Pump, Gear & Engine
- Allison 'Super Suds Sucker' Chem Induction
- 9-Gallon Fuel Tanks for long, uninterrupted runs.
- Hour Meter & Tachometer
- 5000 PSI Safety Pressure Relief Valve
- Marine Battery Box
- Hose, Gun, Lance & Nozzles included.

<b>MODEL</b>	<b>PSI / GPM</b>	<b>ENGINE / AMP</b>	<b>PRICE</b>
SIG5635GR	3500 - 5.6	18 KOHLER / 20*	\$2895.00
SIG8636GR	3600 - 8.6	30 KOHLER / 25*	\$3895.00
SIG1029GR	2900 - 10.0	30 KOHLER / 25*	\$3895.00

\* ELECTRONIC ENGINE IDLE DOWN WHEN SYSTEM IS IN BY-PASS

**COMES WITH 9 GALLON FUEL TANK & BATTERY BOX**

**U-Pay Freight this Page**



# TNT

**UP TO KOHLER**

# 30 HP

# 10 GPM

## TWO GUN

## SMALL FOOTPRINT

## SPACE SAVER

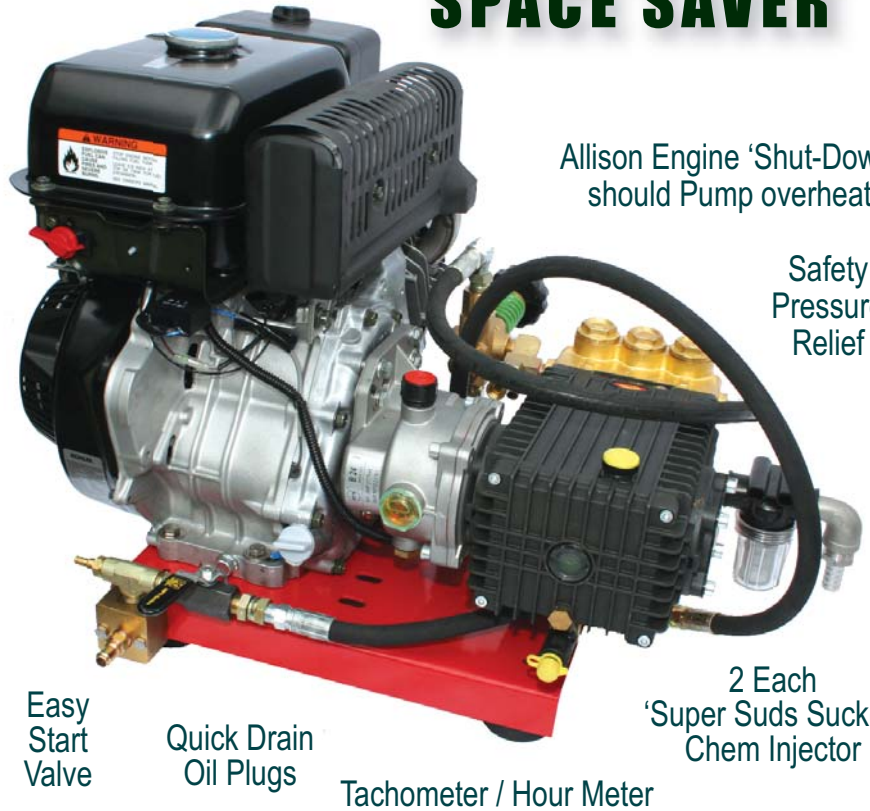

Allison Engine 'Shut-Down' should Pump overheat

Safety Pressure Relief

2 Each 'Super Suds Sucker' Chem Injector

Tachometer / Hour Meter

Quick Drain Oil Plugs

Easy Start Valve



YU2140 Unloader  
The Industry's Best High Volume Unloader

### DUAL BEARING TRANSMISSION DRIVE

#### JUST ADD WATER!

...that and a floor to bolt it down to is all you will need to be up and running with this compact beast!

This pressure washer is for contractors who need more volume, less pressure and quick production times.

**HOT WATER READY!**

**JUST ADD A HEATER**

#### SYSTEM SPECIFICATIONS

P/N & PRICE	Engine	Using One Gun you can run from...	Using Two Guns you can run...
<b>TNT8636</b> <b>\$3495.00</b>	<b>30 HP KOHLER</b>	4.3 GPM @ 3600 PSI up to 8.6 GPM @ 3600 PSI	2 Guns each @ 4.3 GPM & 3600 PSI each
<b>TNT1029</b> <b>\$3495.00</b>	<b>30 HP KOHLER</b>	5.0 GPM @ 2900 PSI up to 10.0 GPM @ 2900 PSI	2 Guns each @ 5.0 GPM & 2900 PSI each

MORE CONFIGURATIONS Available - CALL

**U-Pay Freight this Page**



# ELECTRIC EXHAUST HOOD PRESSURE WASHER

**USE THEIR HOT WATER!**

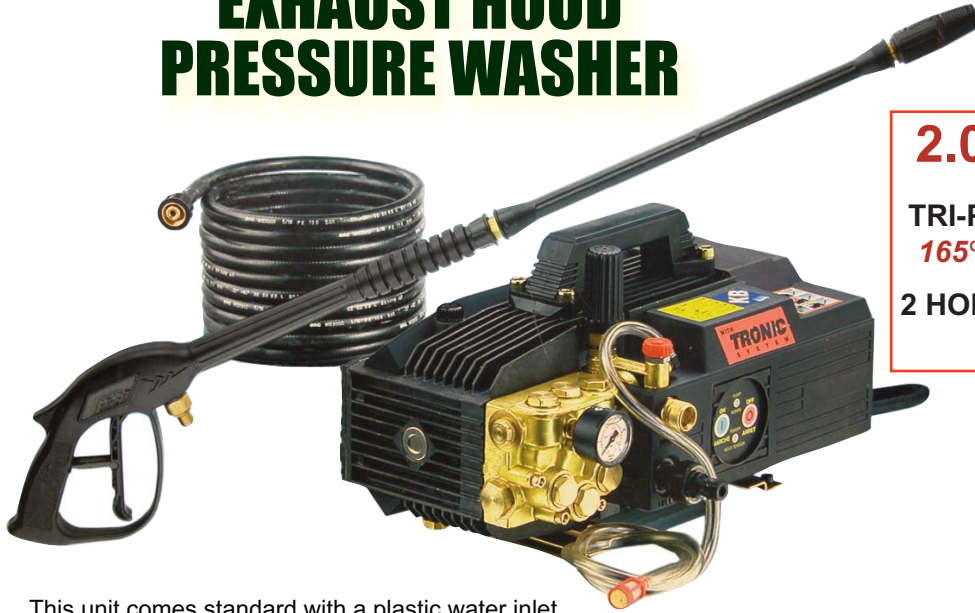

**2.0 GPM @ 1500 PSI**

**TRI-PLEX, CERAMIC PISTON PUMP  
165° 'HOT WATER KIT' INSTALLED**

**2 HORSEPOWER ELECTRIC MOTOR  
WITH GROUND FAULT**

**#9830 \$599.75**

**Hi-Temp Kit  
Installed**

This unit comes standard with a plastic water inlet. A metal inlet is available by ordering #5890 for \$26.92.

# GAS ENGINE EXHAUST HOOD & KITCHEN PRESSURE WASHER

The **PRESSURE** you need to clean **THE TOUGHEST GREASE & GRIME** and the **VOLUME** you need to make **'CLEAN-UP' QUICK AND EASY.**

### THE ADVANTAGES OF GAS OVER ELECTRIC ARE:

You can use it in other applications that require low volume and high pressure such as grease pits & traps, dumpster areas, factory & garage clean-downs plus with gas you'll get much higher pressures than electric.

Also - many restaurants do not have all their electrical outlets set up with 30 amp breakers which makes an electric system inoperable in many restaurant environments.

**2.0 GPM @ 3200 PSI**

**TRI-PLEX, CERAMIC PISTON PUMP  
165° 'HOT WATER KIT' INSTALLED**

**7 HP INDUSTRIAL KOHLER ENGINE  
WITH 3-YEAR WARRANTY**

**#9850 \$1273.00**

System Includes:  
Reel with 100' of 1-wire, 1/4", 4000 psi hose  
Gun, 48" lance, 'QC' Nozzle Set  
Safety pressure relief  
Industrial Unloader  
Industrial Cart, 13" wheels and tool tray



**U-Pay Freight this Page**





**PRESSURE WASHERS  
TRUCK MOUNT/BELT DRIVE**



**24 · 3000PSI**



Includes: 2-100' hoses, guns, injectors, lances & nozzles

**DUAL PUMPER  
TRUCK MOUNT SKID  
8.0 GPM @ 3000 PSI  
GX690 HONDA**

#DP8030CW \$3199.00

ACCESSORIES,  
GAS TANK & BATTERY  
SOLD SEPERATELY



24 · 3000PSI

**20 - 24 · 4000 - 5000PSI**

**ROLL-CAGE SKID/CART  
5.6 GPM @ 3500 PSI  
20 HP GX630 HONDA**

#5635-20H-RC  
\$2899.00



**ROLL-CAGE SKID/CART  
5.0 GPM @ 5000 PSI  
24 HP GX690 HONDA**

#5050-24H-RC  
\$3499.00



- Includes:
- Hondas New Generation GX630 (20) or GX690 (24)
  - Electric Start/Oil Alert
  - 50 Ft High Pressure Hose
  - Spray Gun, Lance
  - Chem Injector
  - Steel Roll Cage Frame
  - 13" Pneumatic Tires
  - Break Mechanism

20 - 24 · 4000 - 5000PSI

**PREMIUM BELT DRIVES**

**U-Pay Freight this Page**





# PREMIUM BELT DRIVE CARTS

STAINLESS STEEL

## COOLDRIVE

Distinguishing Features	
1	Patented Cooling Technology
2	Cool Air Ventilation Slots
3	Perm-A-Line Belt Tension System
4	Laser Aligned Pulley Fanning System
5	Quick-Release Belt Guard Knobs
6	Free Standing S.Steel Belt Guard
7	Flat-Free Foam Filled Tires
8	Industrial Aluminum Mags
9	Block Mounted Unloader

**YOU DON'T HAVE TO BUY  
THIS ANYMORE!**



## BLACK POWDER COAT

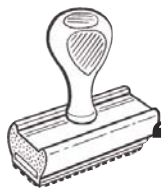

**Not your typical  
'rubber stamped'  
PRESSURE WASHER**

WITH THE NEW GENERATION  
HONDA 13 HP ENGINE  
AND A DESIGN THAT WILL ADD  
YEARS OF TROUBLE FREE LIFE  
TO YOUR BUSINESS



Part Number	Description	Price
CD4035PC	Cool Drive, Powder Coated Frame, 4.0 @ 3500, New Generation Honda	\$1449.00
CD4035SS	Cool Drive, Stainless Steel Frame, 4.0 @ 3500, New Generation Honda	\$1619.00
CD5625PC	Cool Drive, Powder Coated Frame, 5.5 @ 2500, New Generation Honda	\$1549.00
CD5625SS	Cool Drive, Stainless Steel Frame, 5.5 @ 2500, New Generation Honda	\$1719.00

Pic	Feature	Pic	Feature	Pic	Feature
	• 14,000 Cleaning Units	2	13" Foam Filled Tires	7	4 Quick-Connect Spray Tips
	• Honda 13 HP GX390 Gas Engine	3	Chemical Injector		• Industrial Triplex Pump
1	'EZ Start' Adjustable Unloader	4	50' Steel Braided Non-Marking Hose		• Stainless Steel Frame
	• Thermal Relief Valve (145°)	5	5,000 PSI Spray Gun		• Belt Drive
	• Safety Relief Valve	6	36" Insulated Lance		• Box Dimensions: H27", L33", W27"



**HONDA  
ENGINES**

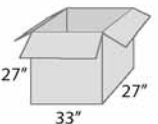

**U-Pay Freight this Page**





# Cheetah Systems

**18 HP KOHLER**

with 3-year warranty



TWO MODLES

**#5635HRC**

5.6 GPM  
3500 PSI  
\$2457.60

**#8025HRC**

8.0 GPM  
2500 PSI  
\$2757.60

Soft-Touch Unloader

Tachometer/Hour Meter

The New Hyde  
51" Pivoting Nozzles Lance

Gun, Hose & Nozzles

3 Quick Drain Oil Plugs

Vibration Isolators between  
engine and base plate

Premium 13" Wheels

Integrated Tool Tray, Reel  
& Nozzle Holders

Engine Shuts Down  
if Pump Overheats



## COMPLETE CART

Build your own!

- Includes:
- 100' Reel
- Tool Tray
- Hose Hanger
- Vibration Mounts
- 13" Premium Tires

#RC-101 \$163.58



**U-Pay Freight this Page**



# CYCLONE BY: ALLISON

Up to 10 GPM  
Up to 300 PSI

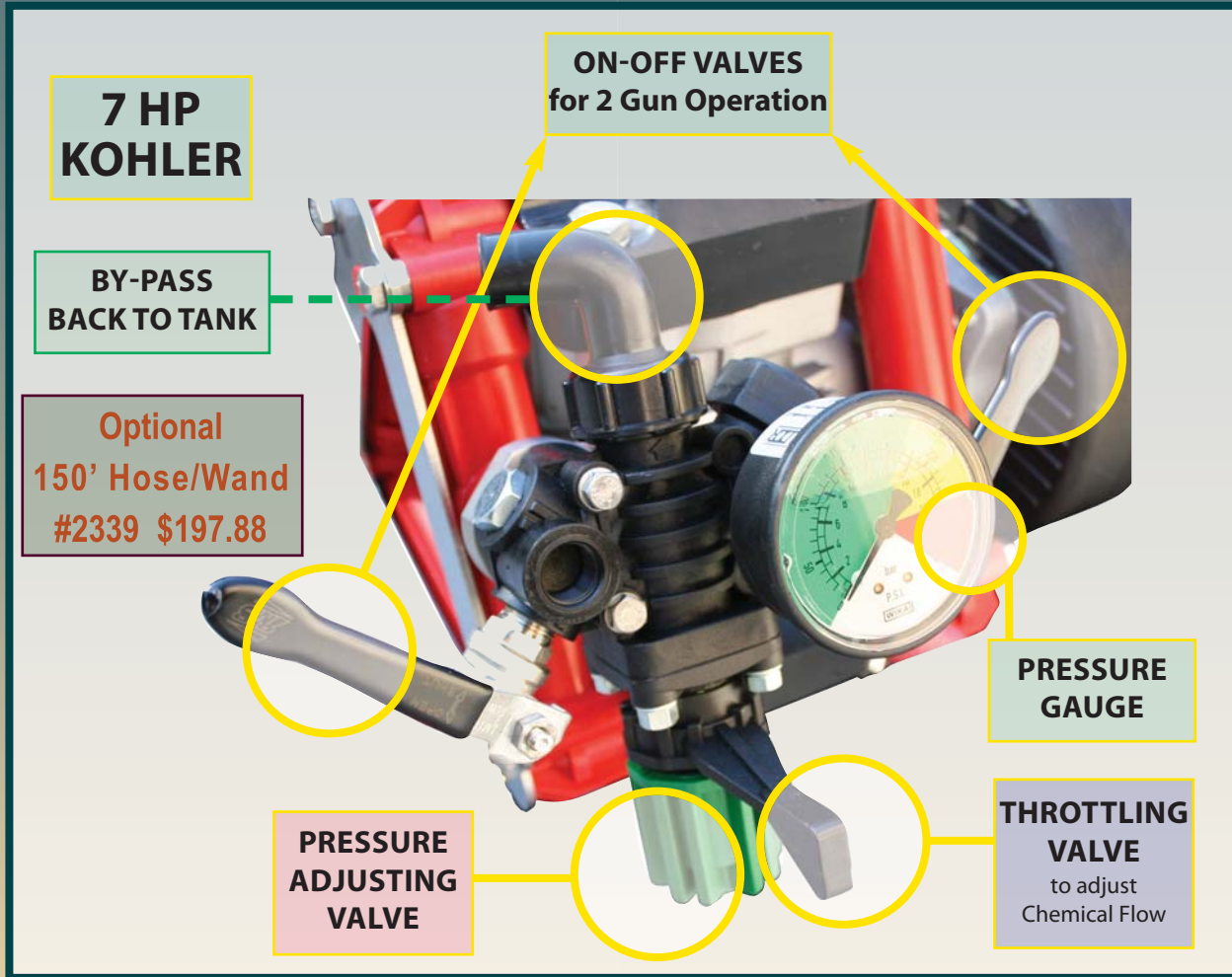

**SORRY! NO TOYS ALLOWED.  
...this area is for real CHLORINE PUMPERS!**

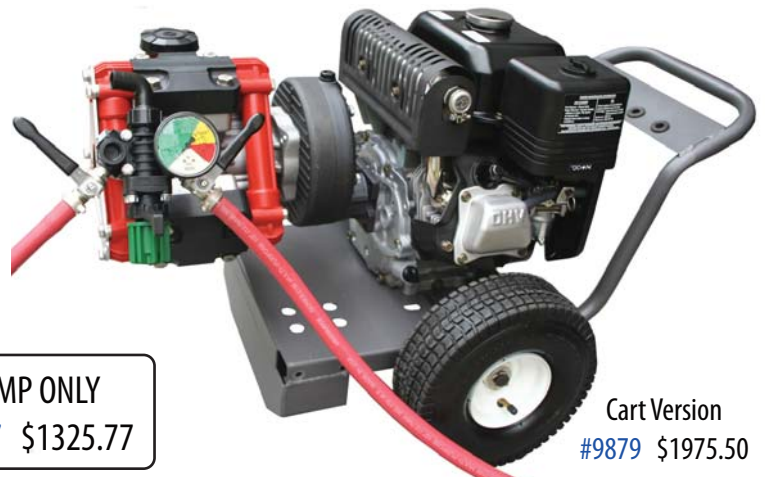
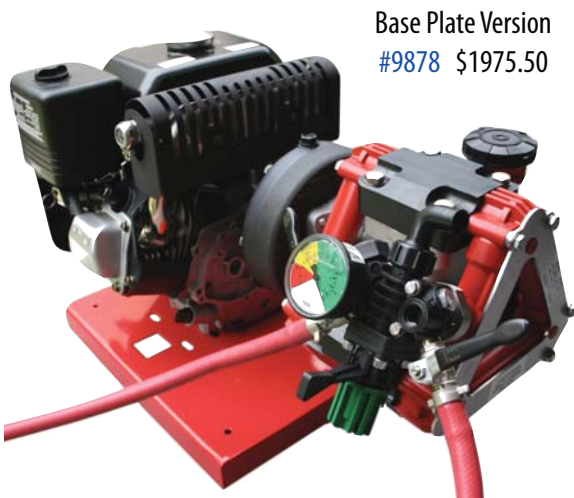

**PUMP ONLY**  
#2777 \$1325.77

**U-Pay Freight this Page**



# WASTE WATER RECOVERY

## HOW DOES VACU-BOOM WORK?

When the wet vac system is turned on, the Vacu-Boom tightly seals itself to the surface like a giant suction cup, to form an impervious liquid barrier. Simultaneously, the waste water or other liquid is extracted into the boom and travels with the airflow through the boom and vacuum hose into the sump of the vacuum unit. The vacuum unit is equipped with an automatic pump out system which discharges water through a discharge hose into a holding tank, filter unit or sanitary sewer.

## WHERE CAN VACU-BOOM BE USED?

- Outdoor vehicle or equipment washing
- In-plant equipment washing
- Emergency storm water containment
- Boats and ships - to prevent deck run-off
- Marinas - to prevent contamination from run-off
- Parking lot/sidewalk washing to capture dirty water run-off
- Emergency hazardous liquid spill containment
- Airports - to capture run-off from aircraft washing

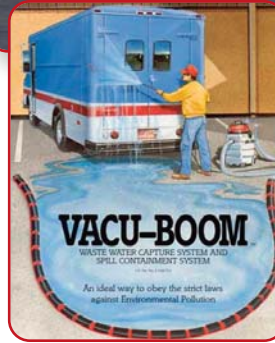

PART #	DESCRIPTION / PRICE	
9300	20' Boom Only	\$ 954.00
9301	40' Boom Only	\$1524.00
9302	101 CFM Vac with Pump-out	\$ 998.20
9303	202 CFM Vac with Pump-out	\$1191.16
9305	Tote Bag	\$ 98.56

# AT LAST! A RECOVERY SYSTEM THAT REALLY WORKS

Recovery at it's best!

## SIROCCO



Part No.	Complete System	Recovery GPM
SGV313	With 14 Subaru	4 - 6
SGV316	With 16 Vanguard	6-12
SGV37	With 7 Subaru	4 - 6
SGV39	With 9 Subaru	4 - 8
SGV416	With 16 Vanguard	8 - 15
SGV423	With 23 Vanguard	10 - 25
SGV431	With 31 Vanguard	15 - 30
SGV435	With 35 Vanguard	To 35 GPM
SGV535	With 35 Vanguard	To 50 GPM

## PART NUMBERS & PRICING

SGV313	\$4,895.00	SGV416	\$5,995.00
SGV316	\$5,695.00	SGV423	\$6,995.00
SGV37	\$3,995.00	SGV431	\$7,395.00
SGV39	\$4,495.00	SGV435	\$7,795.00
		SGV535	\$7,995.00
		SC21V	\$1,895.00

It is all about 'work speed' and affordability.

The Sirocco System is the most asked for recovery systems we have ever sold.



SC21V Vacuuming 21" Surface Cleaner

Call for options list and more information!

U-Pay Freight this Page



# ALLISON IRON HORSE CHEMICAL INDUCTION SYSTEM

**The biggest complaints "EVER" with chemical injectors are:**

1. With more than 125' of hose they won't draw chemical!
2. Although it is a 20% injector it doesn't draw enough chemical!
3. I wish I didn't have to use a 'pump-up' to apply bleach!

## NOW YOUR HEADACHES ARE BEHIND YOU!

The Allison Chem-Induction System which includes the Allison Super Suds Sucker Injector allows you to draw an incredible amount of chemical.

The following test was based on using a typical injector advertised to draw at 20% (**NOT OURS**) mounted on a TS-2021 General Pump running at 5.6 GPM.

1. With 100' of hose - INJECTOR ONLY  
**63 oz. of chem per min.**
2. With 100' of hose & WITH OUR CHEM INDUCTION  
**204 OZ. OF CHEM PER MIN.**

### NOW CHECK THIS OUT!

3. With 500' of hose & a Competitors 20% Injector  
**0 oz. of chem per min.**
4. With 500' of hose & WITH CHEM INDUCTION  
**204 OZ. OF CHEM PER MIN.**

This means that regardless of which problem you are having you will still induct almost 2 gallons of chemical per minute into the system. Never again will you have to apply the product 2 or 3 times to get the job done. Now you'll be on your way after the first pass. Roof Cleaners using bleach really love this system.

**No more 'pump-up' or 'back-pac' sprayers to lug around!**

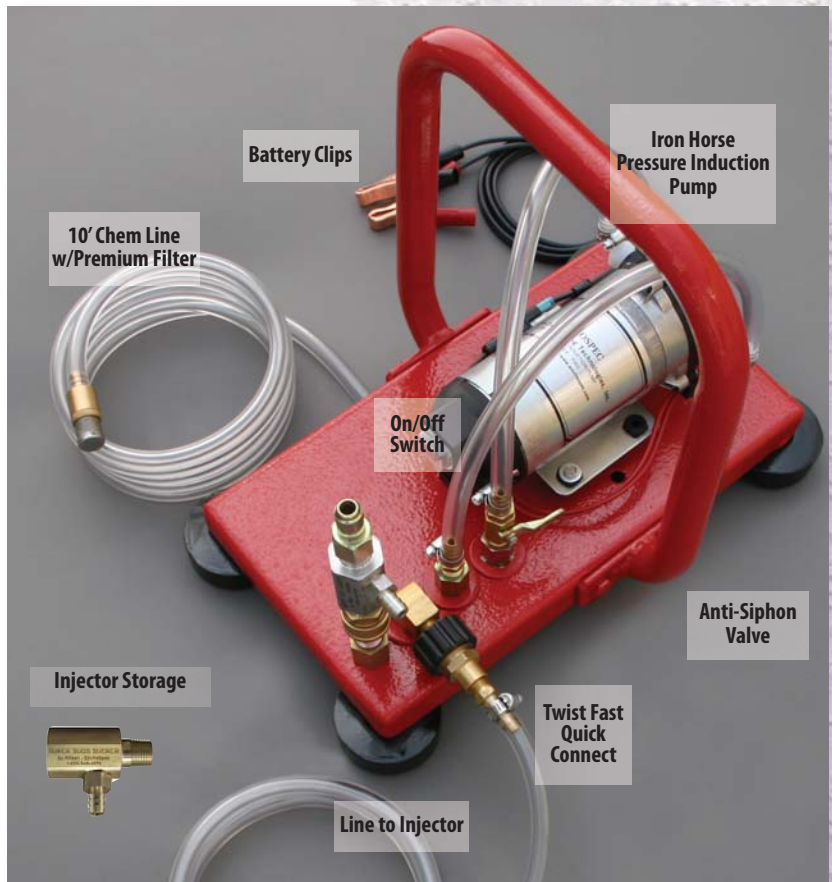

### 12 VOLT, HIGH VOLUME COMES COMPLETE WITH:

- Allison High Induction Chemical Injector
- 4 additional, easily interchangeable injector nozzles that will allow you to use this system on any pressure washer from 2 GPM thru 10 GPM.
- Induction Pump mounted on a convenient 'hand carry' base plate.
- This System can be detached from the Chemical Injector and utilized to spray undiluted chemical when you purchase Part #1596

*The Injector comes set up with convenient 'quick connects'*

*To be used with pressure type unloaders only.*

PART #	DESCRIPTION / PRICE	
1595	CHEMICAL INDUCTION SYSTEM, 12V	\$239.95
1671	REPLACEMENT INDUCTION PUMP	\$102.54
2351	REPLACEMENT DIAPHRAGM ASSEMBLY	\$ 63.55
2352	PRESSURE SWITCH	\$ 24.67
1596	100' HOSE, LANCE & GUN ASSEMBLY	\$127.42

**FREIGHT:** This page we pay the freight on \$50.00 Web Orders or \$200.00 Call-in Orders



# LASER DECK FLAT SURFACE CLEANERS

## SEMI-PROFESSIONAL LASER DECK



### 12 INCH

- Use with an optional spray gun kit
- Attach to a longwand
- Attach to a spray lance

1850 DECK / 2 Nozzles Required \$87.70



1628 GUN & HANDLE KIT \$26.12

### RECOMMENDED SIZES FOR VARIOUS PRESSURE WASHER FLOWS

- 4-5 GPM** 20" 2-BAR
- 5-6 GPM** 20" 2-BAR  
or 24" 3-BAR
- 6-8 GPM** 24" 3-BAR  
or 24" 4-BAR  
or 30" 3-BAR
- 8-12 GPM** 24" 4-BAR  
or 30" 3-BAR  
or 30" 4-BAR

#### NOTE:

For Speed and Quality we recommend that you never use a nozzle size less than #2 and a pattern of 25 degrees.

### LASER DECK ROTARY HEAD BREAKDOWN

#### WHIRL-A-WAY ROTARY HEAD BREAKDOWN

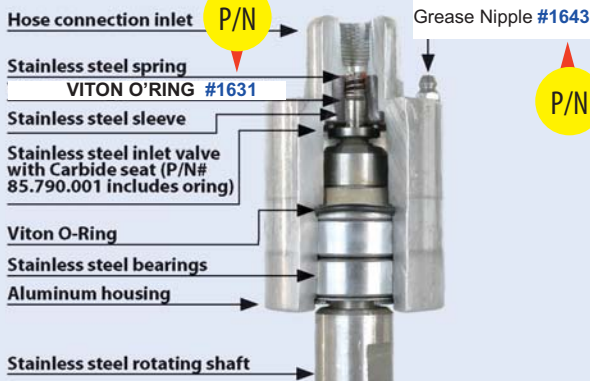

### REPLACEMENT SWIVEL FOR LASER DECKS - 20"-24"

#1632 \$147.71



### CUSTOMER PAYS SHIPPING ON ALL CONCRETE CLEANERS

### 20 INCH

- Two rotary cleaning arms
- Hover action ideal for cleaning rooftops and rough surfaces
- Easy to handle frame is designed for less operator fatigue
- Helps eliminate zebra striping

PART #	DESCRIPTION / PRICE
1853	2 Nozzles Required \$309.43

2-bar Configuration

Remember...  
these units do not come with nozzles.

### STAINLESS STEEL

### 20 & 24 INCH

- Three rotary cleaning arms
- Comes with castors ideal for cleaning driveways and other large flat surfaces
- Stainless Steel design for maximum cleaning durability
- Easy to handle frame is designed for less operator fatigue
- Helps eliminate zebra striping

PART #	DESCRIPTION / PRICE
1845	20" - 2 Nozzle Bar (No Nozzles) \$488.08
1846	20" - 3 Nozzle Bar (No Nozzles) \$498.08
1847	24" - 2 Nozzle Bar (No Nozzles) \$524.41
1848	24" - 3 Nozzle Bar (No Nozzles) \$539.70

**U-Pay Freight on Concrete Cleaners only**



# What is the best set-up?

## P-SWEEP HYDRO-BROOM

*Ours Includes The Nozzles!  
Most Don't!*



Part #	Description	Noz	Price
1886	12" Sweep Only	3	\$29.66
1888	16" Sweep Only	4	\$36.80
1887	12" w/48" Lance & Gun	3	\$52.60
1889	16" w/48" Lance & Gun	4	\$68.17
NOS-05013M	Replacement Nozzle	ea.	\$ 2.75

## LASER DECK PARTS

PART #	DESCRIPTION / PRICE
1641	Swivel Head for 12" \$35.51
1632	Swivel for 20" ABS & 20"-24" Stainless \$147.71
1649	Rotary Arm for 12' 2-Bar \$26.87
1648	Rotary Arm for 20" 2-Bar \$39.12
1647	Rotary Arm for 20" 3-Bar \$48.18
2337	Rotary Arm for 24" 2-Bar \$38.12
1646	Rotary Arm for 24" 3-Bar \$48.77
1635	Swivel Repair Kit for 20", 22", 24" \$119.13
1642	Brush Skirt for 12" \$28.60
1637	Brush Skirt for 20" ABS Plastic \$64.91
1638	Brush Skirt for Stainless 20's \$65.81
1639	Brush Skirt for Stainless 24's \$66.84
1640	Caster Wheel for Stainless 20 & 24's \$29.74
1627	Gun for 20", 24" \$29.89



# IRON HORSE SPINNER

**EnviroSpec Endorsed**  
*as the 'best in the industry' at the best price!*

- Swiss Engineered Stainless Swivel
- Carbide Seal System
- Hi-Torque Load Bearings
- 5000 PSI Easy Spin Design
- 'Quiet Run' Technology
- Rated to 2000 PSI & 250°

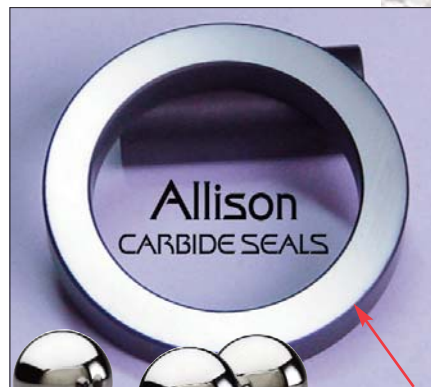

*Balanced Swivel & Arm*



#4801	20" Stainless, 2-Bar	\$589.11
#4802	20" Stainless, 3-Bar	\$595.63
#4803	24" Stainless, 2-Bar	\$658.88
#4804	24" Stainless, 3-Bar	\$664.03
#4805	Replacement Swivel	\$216.62

CUSTOMER PAYS SHIPPING ON ALL  
CONCRETE CLEANERS



## TECH LIBRARY: TRIGGER GUNS

A trigger gun provides an operator with a grip that is designed so the human hand can hold it comfortably. Some designs do a better job providing comfort than others. There are pistol style guns, straight through style guns, front and rear entry guns, open guns, and dump guns. When using any type gun that can stop the water flow, a pressure washer must be equipped with an unloader valve. Using an open gun or a dump gun eliminates the need for an unloader valve.

A pressure relief valve should be installed on equipment regardless of the gun type used, but it is most important when there is no unloader valve. Trigger guns have an inlet port where they are attached to the high-pressure hose. Industry standard for the size of the inlet port is 3/8". The industry standard size of a trigger gun outlet port is 1/4". The two ports are connected together allowing the water to flow through.

Repair or Replacement: Trigger Guns either get damaged because of rough handling, or the seat and ball get damaged or worn. The value of rebuilding a trigger gun is questionable. With most trigger guns selling for \$10.00 to \$29.00, they are generally a throw away and replace item. Rebuild kits are available and very easy to install. Unscrew

and remove the grip. Unscrew the hex cap on top of the valve body. Remove the stem, spring, ball and o-ring. Replace with the new parts from the kit, installing them in the same order. Use thread seal on the threads of the valve body cap, reinstall, and then screw the molded grip back onto the inner gun assembly. Sometimes debris gets caught in the valve assembly and stops the ball from seating properly. This causes the trigger gun to continue to allow water flow after the operator has released the trigger. Pulling and releasing the trigger a few times will fix this problem most of the time.

## HI-TECH Gun No Trigger



GPM: 8  
PSI: 4100 PSI  
TEMP: 300° F

PART #	DESCRIPTION / PRICE
1223	Triggerless Gun Handle \$15.38

## Hose Whips for Trigger Guns

The purpose of the Hose Whip is to extend the life of the quick connects & eliminate leaking. When you are pulling the hose using the gun and lance for leverage you are putting the quick connect in a "metal to metal" bind. When the whip is in place the quick connect coupler and plug will always be pulling in-line with the hose.



Install a whip on inlet side of gun & extend the "quick connect" life ten-fold.

PART #	DESCRIPTION / PRICE
1202	1' 4,000 PSI WHIP Only \$ 6.95
1568	1' WHIP w/Swivel & "QC" \$11.44
1172	2' 4,000 PSI WHIP Only \$ 7.95
4103	2' WHIP w/Swivel & "QC" \$16.45

## 24" Lance/Gun Assembly for 'Close Quarters'



- The bent end for greater surface impact
- Light Weight Stainless Lances and Stainless Valve Body
- Dual Valve Assembly when open draws soap and when closed goes to high pressure rinse
- Comfortable, Relax-Grip Gun for long hours of operation

PART #	DESCRIPTION / PRICE
1259	24", LANCE/GUN ASSEMBLY \$66.39

## Float Valve

- Max Temperature - 140°F
- Max Pressure - 145 PSI
- 3/4" Inlet



PART #	DESCRIPTION / PRICE
1598	FLOAT VALVE 3/4" PLASTIC \$13.85
1599	FLOAT VALVE 3/4" BRASS \$17.63

## Plastic Float Tank with Cover

- Max Temp 140°F
- Capacity - 0.8 US Gal.
- Overall Size - 5" x 10" x 8"
- Material - copolymer



PART #	DESCRIPTION / PRICE
1597	FLOAT TANK with LID & BULKHEAD \$7.93
1234	FILTER 3/8M PLASTIC - 450 MICRON \$7.42

## Hudson Float Valve

Preferred over typical float valves.

- No External Moving Parts
- No Float Ball or Arm
- 90° or 150° Max Temp
- All Stainless, Plastic & Nylon
- 1" Inlet - easy installation
- Automatic anti-siphon



PART #	DESCRIPTION / PRICE
1343	VALVE, 90° TEMP. RATING \$29.62
1344	VALVE, 150° TEMP. RATING \$31.35



## HI-TECH 501 GUN

Easy Access  
Repair Kit Panel



Easy Pull  
Relax Grip  
Design

Permissible  
Ratings:

GPM: 8  
PSI: 4500 PSI  
TEMP: 300° F



PART #	DESCRIPTION / PRICE
1209	HI-TECH 501 GUN \$13.40
1749	CERAMIC KIT \$ 2.95

## HI-TECH 5000



Easy Pull  
Relax Grip  
Design

GPM: 9  
PSI: 5000 PSI  
TEMP: 300° F

PART #	DESCRIPTION / PRICE
1208	HI-TECH 5000 \$19.67
1747	CERAMIC KIT \$ 2.95

## YG 5000

GPM: 11  
PSI: 5000 PSI  
TEMP: 300° F



Chlorine Version Available!

PART #	DESCRIPTION / PRICE
1220	YG5000 \$23.93
1221	YG5000 Chlorine Version \$24.93
1747	CERAMIC KIT \$ 2.95

## PREMIUM IRIDE GUN



Permissible  
Ratings:  
GPM: 8  
PSI: 4700 PSI  
TEMP: 300°



Easy Pull  
Relax Grip  
Design

PART #	DESCRIPTION / PRICE
1225	IRIDE PRO GUN \$24.61
1749	CERAMIC KIT \$ 2.95

## PREMIUM ASTRA GUN



Permissible  
Ratings:  
GPM: 8  
PSI: 5300 PSI  
TEMP: 300°



Easy Pull  
Relax Grip  
Design

PART #	DESCRIPTION / PRICE
3225	ASTRA PRO GUN \$26.87
1749	CERAMIC KIT \$ 2.95

## RL-51 GUN

best with chem injectors!

COMPENSATING  
EASY PULL GUN!

GPM: 13.2  
PSI: 4100 PSI  
TEMP: 320° F



PART #	DESCRIPTION / PRICE
1204	HI-TECH 4100 \$41.82
1205	COMPLETE KIT \$14.01

## RL-56 GUN

COMPENSATING  
EASY PULL GUN!

GPM: 8  
PSI: 5700 PSI  
TEMP: 320° F



PART #	DESCRIPTION / PRICE
1206	HI-TECH 5700 \$43.85
1207	COMPLETE KIT \$15.26

## Arrow Line AL-35

SAFETY YELLOW! →

GPM: 8  
PSI: 5000 PSI  
TEMP: 300° F

best with chem injectors!



PART #	DESCRIPTION / PRICE
1695	ARROW LINE AL-35 \$24.17
1744	CERAMIC KIT \$ 2.95
4404	COMPLETE KIT \$12.24

## GENERAL PUMP DCG GUN

COMPENSATING  
EASY PULL GUN!

GPM: 10.0  
PSI: 5000 PSI  
TEMP: 320° F



PART #	DESCRIPTION / PRICE
1230	DCG GUN \$29.36
1749	CERAMIC KIT \$ 2.95

## YG4000S Lenier

GPM: 10.5 PSI: 4050 PSI TEMP: 300° F



PART #	DESCRIPTION / PRICE
1218	YG4000S \$24.61
1747	CERAMIC KIT \$ 2.95
1219	COMPLETE KIT \$13.67

## Front Entry Gun

GPM: 8.0  
PSI: 3000 PSI  
TEMP: 300° F



PART #	DESCRIPTION / PRICE
1203	FRONT ENTRY GUN \$8.65



## CUSTOM K7 Unloader

Flow Actuated

GPM: 2.1-10.8  
PSI: 3,500 PSI  
TEMP: 165° F



If you are buying K-7's from anyone else they will probably 'surge' in by-pass!

PART #	DESCRIPTION / PRICE
1089	2.1-2.9 GPM - K7.0 \$74.92 (with Anti-Surge By-pass Port)
1090	2.9-4.2 GPM - K7.1 \$74.92 (with Anti-Surge By-pass Port)
1091	4.2-6.6 GPM - K7.2 \$74.92 (with Anti-Surge By-pass Port)
1092	6.6-10.8 GPM - K7.3 \$74.92 (with Anti-Surge By-pass Port)
1789	REPAIR KIT - FITS ALL \$19.61

## K10 Unloader

GPM: 10.8  
PSI: 3,600 PSI  
TEMP: 165° F

One Size Fits All!



PART #	DESCRIPTION / PRICE
1096	UNLOADER, K-10 FLOW ACTUATED \$62.20
1095	REPAIR KIT FOR K-10 \$46.40

## K9 Unloader

GPM: 13.2  
PSI: 5,800 PSI  
TEMP: 195° F

FLOW ACTUATED



PART #	DESCRIPTION / PRICE
1093	UNLOADER, K-9 \$438.08
1094	REPAIR KIT FOR K-9 \$220.84

## K5 Unloader

Flow Actuated

GPM: 2.1-10.8  
PSI: 3,000 PSI  
TEMP: 165° F



PART #	DESCRIPTION / PRICE
1085	2.1-2.9 GPM - K5.0 \$69.95
1086	2.9-4.2 GPM - K5.1 \$69.95
1087	4.2-6.6 GPM - K5.2 \$69.95
1088	6.6-10.8 GPM - K5.3 \$69.95
1785	REPAIR KIT - FITS ALL \$19.61

## VB350 Unloader

GPM: 10.5  
PSI: 5,650 PSI  
TEMP: 195° F



PART #	DESCRIPTION / PRICE
2032	UNLOADER, VB350 \$81.76
2033	REPAIR KIT, VB350 \$36.66

## VB-10 Unloader

SUPER SOFT TOUCH

GPM: 8  
PSI: 4,000 PSI  
TEMP: 195° F

Feels like a FLOW ACTUATED ...but easy to adjust like a PRESSURE ACTUATED!



PART #	DESCRIPTION / PRICE
1108	UNLOADER, PA10 \$69.95
1109	REPAIR KIT FOR VB-10 \$58.73

## YU-2140 Unloader



The best large volume pressure actuated unloader in the industry!

GPM: 21  
PSI: 4,500 PSI  
TEMP: 200°

PART #	DESCRIPTION / PRICE
1100	1/2" In/Out/1 By-pass Port (Blue) \$76.54
1101	1/2" In/Out/ 2 By-pass Ports (Green) \$79.54
1102	ADJUSTABLE KNOB \$ 9.89
1103	Repair Kit \$13.62

## Hi-Tech "MV" Unloader

GPM: 8  
PSI: 2,000-3,600 PSI  
TEMP: 200° F



PART #	DESCRIPTION / PRICE
1118	MV 520 UNLOADER UP TO 2000 PSI \$27.45
1119	MV 540 UNLOADER UP TO 2500 PSI \$29.08
1120	MV 550 UNLOADER UP TO 3600 PSI \$40.34
1121	MV 580 UNLOADER UP TO 4000 PSI \$37.26

## A-R BOLT-ON

- Mini for 'XT' & 'XM' Pumps  
2-5 GPM to 2600 PSI
- Gymatic for 'XM' & 'RK' Pumps  
3-5.5 GPM to 3650 PSI
- Gymatic '3072' 'XM' & 'RK' Pumps  
5 GPM to 4000 PSI



PART #	DESCRIPTION / PRICE
2403	Mini without injector \$57.46
2712	Gymatic with fixed injector \$66.84
2301	Gymatic with adjustable injector \$74.32
3072	Gymatic without injector \$74.77



## #1 SELLER IN 2010

### ALLISON 'SOFT-TOUCH' UNLOADER

Once you use this unloader you will never use another style.

For those of you who like the K7... I guarantee that you will love this unloader.

It feels better than the K-7 and another great feature is that it adjust like a pressure actuated unloader.

This unloader will not cycle like the K7's.

**#7637 \$59.88** w/o Micro Switch - Replaces all other unloaders

**#7638 \$69.88** with Micro Switch (Used on Allison Clutch Drive & Idle Down Systems)

**#7639 \$12.66** Replacement Micro-Switch

Got a leaky hose or quick connect? This unloader re-cycles LESS than any unloader on the market!

With a 15 amp mico-switch for controlling Clutches, Idle Downs & Burners. Install the Allison Soft-Touch unloader, connect a couple of wires and you are ready to go.



**GPM:** 9.0  
**PSI:** 3,650 PSI  
**TEMP:** 195° F

### AL-607 Premium Series



**GPM:** 10.5  
**PSI:** 4,500 PSI  
**TEMP:** 195° F

PART #	DESCRIPTION / PRICE
3111	AL-607P SERIES \$43.59
3112	REPAIR KIT \$12.85

### AL-607 Standard Series



**GPM:** 8.0  
**PSI:** 4,500 PSI  
**TEMP:** 190° F

PART #	DESCRIPTION / PRICE
1114	AL-607X UNLOADER \$39.62
1113	REPAIR KIT \$18.45

### Unloader Mounting Block

- Takes the load off of the pump head
- Solid brass
- Rated to 5,000 PSI



PART #	DESCRIPTION / PRICE
1081	3/8" X 3/8" \$12.97
1082	3/8" X 1/2" \$12.95
1083	1/2" X 1/2" \$12.97

### K-7 & K-5 Unloader Hi-Spike By-pass Hose

- Flexible 1/4" 'hi-spike' line
- Eliminates "surging" on flow actuated unloaders
- 300 PSI working
- 1,200 PSI burst



**Eliminates "Surging"**

PART #	PRICE
1195	\$1.88 PER FOOT

### Control Set Unloader



**FITS GENERAL 47 Series EZ Series TX Series**

**GPM:** 8.0  
**PSI:** 3,650 PSI  
**TEMP:** 195° F

PART #	DESCRIPTION / PRICE
1110	BOLT ON FOR GENERAL, NO INJECTOR \$74.45
1112	BOLT ON FOR GENERAL WITH INJECTOR \$71.26
1111	REPAIR KIT FOR EITHER \$18.63

### PREMIUM UNLOADER BY-PASS HOSE

**800 PSI**



This is the ONLY HOSE that you should be using to by-pass water either back to the tank (open loop) or back to the inlet side of the pump (closed loop.)



PART #	DESCRIPTION / PRICE
3399	3/8" ID, 800 PSI, PER FOOT \$1.01
3400	1/2" ID, 800 PSI, PER FOOT \$1.17

### YU831 Unloader

**GPM:** 8  
**PSI:** 4,000 PSI  
**TEMP:** 195° F

#### Multi-Port By-Pass Ports

PART #	DESCRIPTION / PRICE
1104	UNLOADER, YU-831 PULSAR \$39.63
1098	REPAIR KIT \$14.77



### Pulsar Unloader

**GPM:** 8  
**PSI:** 4,000 PSI  
**TEMP:** 195° F

PART #	DESCRIPTION / PRICE
1099	UNLOADER, PULSAR \$42.83
1098	REPAIR KIT \$14.77





## In-Line Swivels

- Swivels at max pressure
- 5,000 PSI rated - Adams
- 4,000 PSI rated - NorthStar

### ALLISON INDUSTRIAL BRAND

1543	IN-LINE SWIVEL, 1/4" BRASS	\$4.88
1544	IN-LINE SWIVEL, 3/8", BRASS	\$4.88
1545	IN-LINE SWIVEL, STAINLESS, 1/4"	\$8.88
1546	IN-LINE SWIVEL, STAINLESS, 3/8"	\$9.88

### J. E. ADAMS BRAND

1127	INLINE SWIVEL, 1/4" BRASS	\$ 7.63
1351	INLINE SWIVEL, STAINLESS, 1/4"	\$11.50
1433	INLINE SWIVEL, STAINLESS, 3/8"	\$13.64



## Gun to Lance & Hose to Gun Swivels

- Swivels at Max Pressure
- 4,100 PSI Acceptable
- 10.5 GPM
- 250° F

PART #	DESCRIPTION / PRICE	
1144	SWIVEL, INLINE, 1/4"FX 1/4"M - Mosmatic	\$32.30
1145	SWIVEL, INLINE, 1/4"FX 3/8"M - Mosmatic	\$32.30
1146	SWIVEL, INLINE, 3/8"FX 3/8"M - Mosmatic	\$29.95
5114	SWIVEL, INLINE, 1/4"FX 1/4"M - M-T-M	\$52.70
5138	SWIVEL, INLINE, 3/8"FX 3/8"M - M-T-M	\$52.70

## Twist Fast "Quick Connects"



PART #	DESCRIPTION / PRICE	
1937	TWIST FAST COUPLER, 1/4" FPT	\$3.24
1940	TWIST FAST COUPLER, 1/4" MPT	\$3.24
1943	TWIST FAST COUPLER, 3/8" FPT	\$3.24
1946	TWIST FAST COUPLER, 3/8" MPT	\$3.24
1925	TWIST FAST PLUG, 1/4" FPT	\$2.11
1928	TWIST FAST PLUG, 1/4" MPT	\$2.11
1931	TWIST FAST PLUG, 3/8" FPT	\$2.11
1934	TWIST FAST PLUG, 3/8" MPT	\$2.11

## 'O' Ring Pick

For removing o-rings from Check Valves & Quick Connects



PART #	DESCRIPTION / PRICE	
1600	'O' RING PICK	\$3.33

## Ceramic Balls

### Aluma-Oxide

- Replacement balls for highly corrosive environments
- Use with Chemical Injectors and Guns



PART #	DESCRIPTION / PRICE	
1746	CERAMIC BALL, ALUM OXIDE, 1/4"	\$2.95
1747	CERAMIC BALL, ALUM OXIDE, 5/16"	\$2.95
1744	CERAMIC BALL, ALUM OXIDE, 11/32"	\$2.95
1745	CERAMIC BALL, ALUM OXIDE, 13/32"	\$2.95
1749	CERAMIC BALL, ALUM OXIDE, 9/32"	\$2.95

## Hi-Heat "Couplers"

To hot to handle? These couplers make it easier to disconnect hoses & accessories without burning your fingers.



PART #	DESCRIPTION / PRICE	
1818	EASY GRIP COUPLER, 1/4" MPT	\$3.88
1817	EASY GRIP COUPLER, 1/4" FPT	\$3.88
1820	EASY GRIP COUPLER, 3/8" MPT	\$3.88
1819	EASY GRIP COUPLER, 3/8" FPT	\$3.88

## 'Push & Snap' Quick Coupler

The Most Incredible Quick Couplers YOU WILL EVER SEE!



This shows the coupler in the 'staged' open position. It remains this way until you push in the plug. When you do the coupler automatically 'snaps' closed.

Here you see just how easy it is to attach a 'quick connect' plug.

**Simply insert the plug & push!**

When you want the plug to release you will pull down on the collar and the plug will automatically release itself and 'snap' out of the coupler.

PART #	DESCRIPTION / PRICE	
1901	1/4" FPT	\$4.93
1902	3/8" FPT	\$4.93

On this page we pay the freight on \$50.00 Web Orders or \$200.00 Call-in Orders





**HARDENED BALL BEARINGS!  
EPDM O'RINGS STANDARD!**



# 'USA' - BRECO - 'USA' COUPLINGS & PLUGS ARE BACK!

PART #	BRECO COUPLINGS / PRICE
BC4F	1/4" FPT In, 1/4" Out \$2.48
BC4M	1/4" MPT In, 1/4" Out \$2.48
BC8F	3/8" FPT In, 3/8" Out \$2.73
BC8M	3/8" MPT In, 3/8" Out \$2.73

PART #	BRECO PLUGS / PRICE
BP4F	1/4" FPT In, 1/4" Out \$.79
BP4M	1/4" MPT In, 1/4" Out \$.79
BP8F	3/8" FPT In, 3/8" Out \$.99
BP8M	3/8" MPT In, 3/8" Out \$.99

## STAINLESS BRECO



PART #	Breco-Foster Couplings
SBC4F	1/4" FPT In, 1/4" Out \$5.18
SBC4M	1/4" MPT In, 1/4" Out \$5.18
SBC8F	3/8" FPT In, 3/8" Out \$7.18
SBC8M	3/8" MPT In, 3/8" Out \$7.18

PART #	Breco-Foster Plugs
SBP4F	1/4" FPT In, 1/4" Out \$3.94
SBP4M	1/4" MPT In, 1/4" Out \$3.94
SBP8F	3/8" FPT In, 3/8" Out \$4.20
SBP8M	3/8" MPT In, 3/8" Out \$4.20

## Premium Brass Coupler

Brass Coupler with 'Safety Loc System'



Shown: Brass Female Pipe Thread (FPT)

PART #	DESCRIPTION / PRICE
QS4FB	1/4" FPT In, 1/4" Out \$1.99
QS4MB	1/4" MPT In, 1/4" Out \$1.99
QS8FB	3/8" FPT In, 3/8" Out \$2.37
QS8MB	3/8" MPT In, 3/8" Out \$2.37

## Premium Stainless Coupler

Stainless Coupler with 'Safety Loc System'



Shown: Stainless Steel Male Pipe Thread (MPT)

PART #	DESCRIPTION / PRICE
QS4FS	1/4" FPT In, 1/4" Out \$2.99
QS4MS	1/4" MPT In, 1/4" Out \$2.99
QS8FS	3/8" FPT In, 3/8" Out \$3.63
QS8MS	3/8" MPT In, 3/8" Out \$3.63

## Premium Plated Steel Plugs

"Super Hard" Plated Steel Plug



Shown: Female Pipe Thread (FPT)

PART #	DESCRIPTION / PRICE
QP4FB	1/4" FPT In, 1/4" Out \$.59
QP4MB	1/4" MPT In, 1/4" Out \$.59
QP8FB	3/8" FPT In, 3/8" Out \$.68
QP8MB	3/8" MPT In, 3/8" Out \$.68

## Premium Stainless Plugs

"Super Hard" Stainless Plug



Shown: Stainless Male Pipe Thread (MPT)

PART #	DESCRIPTION / PRICE
QP4FS	1/4" FPT In, 1/4" Out \$1.38
QP4MS	1/4" MPT In, 1/4" Out \$1.38
QP8FS	3/8" FPT In, 3/8" Out \$1.71
QP8MS	3/8" MPT In, 3/8" Out \$1.71

# 11,000 PSI O'RINGS



These Premium O'rings have been recommended as the best for the three major issues of the **PROFESSIONAL CONTRACTOR:**

**PRESSURE + HEAT + CHEMICAL**

○ ULTRA HIGH PSI ○ ULTRA HIGH HEAT

PART #	DESCRIPTION / PRICE
<b>'EXTREME' DUTY CYCLE O'RINGS</b>	
QOR4X	1/4", 11,000 PSI, 500°, 20 EACH \$12.97
QOR8X	3/8", 11,000 PSI, 500°, 20 EACH \$12.97

## Standard Replacement 'O' Rings

PART #	DESCRIPTION / PRICE
<b>EPDM 'O' RINGS - Chemical Resistance: Moderate</b>	
QOR4E	1/4", 300°, BLACK, 50 EACH \$ 7.67
QOR8E	3/8", 300°, BLACK, 50 EACH \$ 7.67
<b>VITON 'O' RINGS - Chemical Resistance: Severe</b>	
QOR4V	1/4", 350°, BROWN, 50 EACH \$11.73
QOR8V	3/8", 350°, BROWN, 50 EACH \$11.73



## Severe Duty Premium 'O' Rings

**4,000 PSI + Chemical Resistance = SEVERE**

These Premium O'rings have been recommended for the three major issues of the **PROFESSIONAL CONTRACTOR:**

**PRESSURE + HEAT + CHEMICAL**

When you combine all 3 environments the only O'ring that holds up better are the 11,000 PSI Series.

PART #	DESCRIPTION / PRICE
1960	1/4" SEVERE DUTY 'O' RINGS - 50 EACH \$18.84
1961	3/8" SEVERE DUTY 'O' RINGS - 50 EACH \$18.84

On this page we pay the freight on \$50.00 Web Orders or \$200.00 Call-in Orders



# Allison "Super Suds Sucker" **Up to 33(+)% DRAW**

## The Original "Super Suds Sucker" is back!

For those of you to new or young to remember...  
...a few years back we designed a chemical injector that would just about suck the bottom out of the pail. Not only that - we were able to put as much as 500' of hose on the machine and still suck as much chemical as most injectors equipped with only 50' of hose.

Here are the two primary advantages of owning a **Super Suds Sucker** and when you think about it - what else is there?

**Longevity** - This could be the last injector you will ever buy. Most of the ones we built 10 years ago are still 'sucking' strong.

**Product to Surface** - When we first came out with this product we told people then that "if you can't get the product to the surface you may as well stay at home" - the same holds true today. With a **Super Suds Sucker** you will definitely get the product to the surface.



For over 20 years...

**John Allison** operated a Mobile Wash company. During this time he recognized that all chemical injectors had one thing in common. None of them could get enough chemical on the surface. Since that time Mr. Allison has designed some of the finest injectors in the industry under the "**Super Suds Sucker**" logo. However, in the past the manufacturing cost was so high that it made it difficult to bring them to market.

**But** now you can experience the precision of these high induction injectors at a much more affordable price!

PART #	DESCRIPTION / PRICE	
1964	ALLISON SUPER SUDS SUCKER	\$ 38.88
1439	REPAIR KIT	\$ 9.89
2108	Replacement Noz #1	\$ 3.50
2109	Replacement Noz #2	\$ 3.50
2110	Replacement Noz #3	\$ 3.50
2111	Replacement Noz #4	\$ 3.50

Super Suds Sucker comes with additional nozzles that will handle from 2 to 10 GPM.  
Complete with...  
quick connects, chemical line & chemical filter.  
**READY TO GO!**

What do most people say when they first try it?  
**NOW THIS SUCKS!**  
TRY A **Super Suds Sucker** TODAY!

## Stainless Dual Stage

- Stainless Steel construction for extended life.
- Draw from one chem or two.
- With both lines in the solution you can expect to draw up to 30% more product.



PART #	DESCRIPTION / PRICE	
1139	DUAL PORT INJECTOR	\$84.63
1740	REPAIR KIT	\$ 9.37

## Allison "Suds Sucker"

THE BEST "DRAW RATES" IN THE INDUSTRY DESIGNED BY: **ALLISON**

These unique features guarantee you  
Allison Injectors are the best in the industry!

- Up to 20% draw rate
- Machined Brass
- Ceramic Ball for harsh chemicals & chlorine
- 316 Stainless Nozzle
- Rated to 5,000 PSI
- Viton® O'ring

**22%  
DRAW  
RATE**

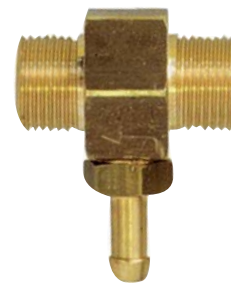

Ideally suited for the contractor who uses a lot of bleach and acid and needs economical disposable injectors.

PART #	DESCRIPTION / PRICE	
1446	ADJUSTABLE WITH CERAMIC BALL, 2-5 GPM	\$9.88
1448	ADJUSTABLE WITH CERAMIC BALL, 5-8 GPM	\$9.88
1441	NON-ADJUSTABLE WITH CERAMIC BALL, 2-5 GPM	\$9.88
1443	NON-ADJUSTABLE WITH CERAMIC BALL, 5-8 GPM	\$9.88

## Chem Line & Filter

Comes with our best  
Stainless & Brass Chemical Filter  
...and 5' of Chemical Line



PART #	DESCRIPTION / PRICE	
1154	CHEMICAL FILTER AND LINE	\$3.78

## Check Valve

- 1/4" MxF with a cracking pressure of 1/3 PSI



PART #	DESCRIPTION / PRICE	
4510	CHECK VALVE	\$3.78



## Allison "Suds Sucker" Double Gulp Injectors

As the old saying goes...

**27+%  
DRAW**



Adjustable

...if you can't get enough product on the surface you may as well stay at home.

What makes this injector different from the others?

- Solid machined brass
- Ceramic Ball Standard
- Viton O'ring Standard
- Hardened Stainless Nozzle

SHOWN WITH  
OPTIONAL  
QUICK  
CONNECTS

You'll get much more chem draw with both lines in the same solution.

**27+%  
DRAW**



Non-Adjustable

PART #	DESCRIPTION / PRICE	
<b>NON-ADJUSTABLE</b>		
1737	DUAL PORT, ALLISON, 2-5 GPM	\$19.63
1739	DUAL PORT, ALLISON, 5-8 GPM	\$19.63
<b>ADJUSTABLE</b>		
1736	DUAL PORT, ALLISON, 2-5 GPM	\$23.63
1738	DUAL PORT, ALLISON, 5-8 GPM	\$23.63
1740	REPAIR KIT FITS ALL	\$11.31

## Plastic Chemical Filter

- Weight holds filter on the bottom
- Use with 1/4" or 3/8" chemical tubing
- Corrosion resistant plastic



PART #	DESCRIPTION / PRICE	
1150	STRAINER W/CHECK	\$1.19
1151	STRAINER W/O CHECK	\$1.19

## Ready-to-Go "Suds Sucker"

Complete with Stainless Quick Connects, 10' of Chemical Line, Our Best Stainless & Brass Chemical Filter.

**20+%  
DRAW**



## Allison All Stainless Injectors

**20+%  
DRAW**



Adjustable



Non-Adjustable

PART #	DESCRIPTION / PRICE	
<b>NON-ADJUSTABLE</b>		
1140	NON-ADJUSTABLE, 2-5 GPM	\$39.34
1141	NON-ADJUSTABLE, 5-8 GPM	\$39.34
<b>ADJUSTABLE</b>		
1142	ADJUSTABLE, 2-5 GPM	\$45.63
1143	ADJUSTABLE, 5-8 GPM	\$45.63
1439	REPAIR KIT FITS ALL	\$ 9.89

## Poly & Stainless Filters

- 1/4" hose barb
- Stainless check ball



PART #	DESCRIPTION / PRICE	
1152	FILTER W/O CHECK - Red Poly	\$4.57
1149	FILTER, ALL STAINLESS	\$1.69

PART #	DESCRIPTION / PRICE	
<b>NON-ADJUSTABLE</b>		
1442	NON-ADJ. READY TO GO, 2-5 GPM	\$19.89
1444	NON-ADJ. READY TO GO, 5-8 GPM	\$19.89
<b>ADJUSTABLE</b>		
1447	ADJ. READY TO GO, 2-5 GPM	\$22.77
1449	ADJ. READY TO GO, 5-8 GPM	\$22.77
1439	REPAIR KIT FITS ALL	\$ 9.89

## Robo Chem Injector

- Stainless orifice
- Stainless check valve



PART #	DESCRIPTION / PRICE	
1135	2.2-4.0 GPM, ROBO CHEM	\$24.12
1136	4.0-5.6 GPM, ROBO CHEM	\$24.12
1137	5.6-10.9 GPM, ROBO CHEM	\$24.12
1138	REPAIR KIT FITS ALL	\$ 7.37

## Premium Chemical Filter **By Far The Best!**

- Solid Stainless and Brass construction
- Larger than others - allows more chemical flow
- Removable, internal "check" prevents chems from back flowing.



PART #	DESCRIPTION / PRICE	
1153	CHEMICAL STRAINER, PREMIUM	\$2.79

## "Sludge Sucker"

- Place the black foot into the flooded area. Connect the pressure washer hose to the foot. Stretch out the blue discharge hose and pull the trigger on the pressure washer and watch the flooded area disappear.



PART #	PRICE
1348	\$49.44



## Safety Relief Valve

- Fully adjustable
- Rated up to 6,000 PSI
- Handles up to 12 GPM
- Rated to 195°F



PART #	DESCRIPTION / PRICE
1123	RELIEF VALVE, 3/8" MPT \$11.87
1126	RELIEF VALVE, 3/8 W/ BARB \$13.69

## Easy Start Valve

- Installs on the high pressure (outlet) side of the pump and relieves the "back-pressure" during start-up.



PART #	DESCRIPTION / PRICE
1124	EZ START VALVE \$11.88

## Pump Thermal Protector

- Installs on the inlet side of the pump
- When by-pass water reaches 145° the valve opens to allow heated water to escape to atmosphere.



PART #	DESCRIPTION / PRICE
1076	1/2" END DISCHARGE \$ 8.86
5575	3/8" END DISCHARGE \$ 8.93
1062	3/8" SIDE DISCHARGE \$12.84

## Chemical Metering Valve

- Stainless & Brass
- Rated to 4,000 PSI
- Viton gland seals
- Panel mountable
- Heavy duty brass bar stock



PART #	PRICE
2447	\$11.80

## Exhaust Hood Swivels, Non-Adjustable

**MOSMATIC  
HOT WATER SWIVELS**

- Fixed nozzle positioning ideally suited to be dropped down the exhaust hood.

To order the correct nozzles take the nozzle that you are presently using and divide it by the number of nozzles required by the Exhaust Hood Swivel you are ordering. For example: If you typically use a #6 nozzle such as a #1506 and you are buying a 3-Nozzle Swivel you will order 3 each #2 nozzles such as a #1502.



These swivels require  
1/8" MEG Nozzles  
Sold Separately

PART #	DESCRIPTION / PRICE
<b>2-NOZZLE HIGH SPEED</b>	
1519	FIXED, 3", 2 NOZZLE \$252.88
1520	FIXED, 6", 2 NOZZLE \$258.01
1521	FIXED, 12", 2 NOZZLE \$263.05
1522	FIXED, 16", 2 NOZZLE \$268.10
1523	FIXED, 20", 2 NOZZLE \$288.27
1524	FIXED, 24", 2 NOZZLE \$293.31
<b>3-NOZZLE HIGH SPEED</b>	
1531	FIXED, 3", 3 NOZZLE \$257.93
1532	FIXED, 6", 3 NOZZLE \$263.05
1533	FIXED, 12", 3 NOZZLE \$268.10
1534	FIXED, 16", 3 NOZZLE \$273.14
1535	FIXED, 20", 3 NOZZLE \$303.31
1536	FIXED, 24", 3 NOZZLE \$308.35

## Exhaust Hood Swivels, Adjustable

**MOSMATIC  
HOT WATER SWIVELS**

- Adjustable nozzle positioning to allow the swivel to pull itself.

To order the correct nozzles take the nozzle that you are presently using and divide it by the number of nozzles required by the Exhaust Hood Swivel you are ordering. For example: If you typically use a #6 nozzle such as a #1506 and you are buying a 3-Nozzle Swivel you will order 3 each #2 nozzles such as a #1502.



These swivels require  
1/8" MEG Nozzles  
Sold Separately

PART #	DESCRIPTION / PRICE
<b>2-NOZZLE HIGH SPEED</b>	
1525	ADJUSTABLE, 3", 2 NOZZLE \$249.61
1526	ADJUSTABLE, 6", 2 NOZZLE \$264.01
1527	ADJUSTABLE, 12", 2 NOZZLE \$276.30
1528	ADJUSTABLE, 16", 2 NOZZLE \$284.87
1529	ADJUSTABLE, 20", 2 NOZZLE \$307.43
1530	ADJUSTABLE, 24", 2 NOZZLE \$312.47
<b>3-NOZZLE HIGH SPEED</b>	
1537	ADJUSTABLE, 3" 3 NOZZLE \$267.09
1538	ADJUSTABLE, 6" 3 NOZZLE \$282.21
1539	ADJUSTABLE, 12" 3 NOZZLE \$287.26
1540	ADJUSTABLE, 16" 3 NOZZLE \$302.30
1541	ADJUSTABLE, 20" 3 NOZZLE \$312.86
1542	ADJUSTABLE, 24" 3 NOZZLE \$317.52



**It's time to GET LEGAL!  
GET A FREE COPY OF 'CLAWS'**

Order #CLAWS

**EAGLE**  
**C.L.A.W.S.**

**COMPLIANCE SOLUTIONS**

**C**ontainment  
**L**iquid Handling  
**A**ssessment  
**W**aste Management  
**S**afety Storage

**EAGLE** MANUFACTURING COMPANY

**ROOF CLEANER** from: **MOSMATIC**

#1863  
\$976.42

height (adjustable) from 7.7"-9"

Nozzles Not Included

Wheel Width (adjustable) from 21.6"-25.2"

Max Pressure 4000 PSI  
Nozzles Not Included

Stainless Steel Housing provide approximately 21" of Cleaning

Weight 31.9 lbs

**Super Heavy Duty Sand Blast Kit\***

Heavy Duty  
PSI: 5,500  
GPM: 10  
Weight: 9.25 lbs.

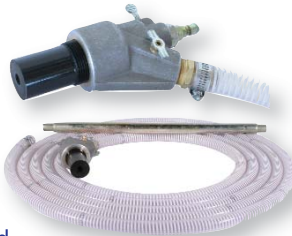

\*0° Nozzle Required

PART #	DESCRIPTION / PRICE
1288	SAND BLAST KIT W/25' OF HOSE* \$69.84

**Commercial Sand Blast Kit**

Medium Duty  
PSI: 3,500  
GPM: 10  
Weight: 9.25 lbs.



PART #	DESCRIPTION / PRICE
1287	KIT, W/10' OF HOSE & PROBE \$39.29

**Roof & Ice Walkers**

High quality, easy to put over boots. These walkers provide fantastic traction. Don't risk a fall, keep these on your truck for use in slippery conditions.



Unique 360° spike pattern provides more push off and lateral grip. The replaceable Ice Diamond™ carbide spikes are integrated into the new open/close split rubber tread for ultimate traction.



PART #	DESCRIPTION / PRICE
1683	4-7 SHOE \$27.88
1684	7-10 SHOE \$27.88
1685	10-14 SHOE \$27.88

**Industrial Drill Mixer**

- If you buy powdered detergent you must have this tool.
- Attach to any heavy duty drill
- High speed chemical mixing thoroughly dissolves chemical



PART #	DESCRIPTION / PRICE
1957	DRILL MIXER, 5 GALLON \$12.63



## STAINLESS STEEL FITTINGS



## BRASS FITTINGS

### COUPLINGS

#BRF454	1/4"	\$1.08
#BRF456	3/8"	\$1.97
#BRF458	1/2"	\$2.83

### STREET EL 45 DEG

#BRF634	1/4"	\$2.21
#BRF636	3/8"	\$2.94
#BRF638	1/2"	\$3.96

### STREET EL 90 DEG

#BRF604	1/4"	\$1.25
#BRF606	3/8"	\$2.54
#BRF608	1/2"	\$4.96

### ELBOW - FPT x FPT

#BRF554	1/4"	\$2.58
#BRF556	3/8"	\$2.84
#BRF558	1/2"	\$3.87

### TEE

#BRF854	1/4"	\$2.55
#BRF856	3/8"	\$3.31
#BRF858	1/2"	\$4.76

### BRANCH TEE

#BRF875	1/4"	\$3.52
#BRF877	3/8"	\$3.69
#BRF879	1/2"	\$5.53

### STREET TEE

#BRF884	1/4"	\$3.03
#BRF886	3/8"	\$3.27
#BRF888	1/2"	\$5.47

### CROSS - 4-WAY

#BRF664	1/4"	\$3.38
#BRF666	3/8"	\$5.75

### PLUG

#BRF804	1/4"	\$1.05
#BRF806	3/8"	\$1.33
#BRF808	1/2"	\$1.97

### BUSHING - MPT x FPT

#BRF404	3/8" x 1/4"	\$1.02
#BRF407	1/2" x 3/8"	\$1.29
#BRF410	3/4" x 3/8"	\$2.37

### BARB MENDER

#BRF200	1/4"	\$1.08
#BRF204	3/8"	\$1.08

### HEX NIPPLE

#BRF754	1/4"	\$1.67
#BRF756	3/8"	\$1.78
#BRF758	1/2"	\$2.29

### NIPPLE

#BRF712	1/4" x 2"	\$1.29
#BRF724	3/8" x 3"	\$3.56
#BRF733	1/2" x 3"	\$3.91

### HEX PIPE NUT

#BRF064	1/4"	\$1.40
#BRF065	3/8"	\$1.74

### BARB 90 DEG

### BARB X MPT

#BRF370	1/4" X 1/4"	\$2.39
#BRF372	3/8" X 3/8"	\$2.74

### HOSE BARBS - BRB X MPT

#BRF354	1/4" x 1/4"	\$1.05
#BRF358	3/8" x 3/8"	\$1.29
#BRF362	1/2" x 1/2"	\$1.98
#BRF368	3/4" x 3/4"	\$2.64

### BUSHING - MPT x FPT

#SSF404	3/8" x 1/4"	\$3.95
#SSF407	1/2" x 3/8"	\$3.95
#SSF411	3/4" x 1/2"	\$4.95
#SSF413	1" x 3/4"	\$6.95

### TEE

#SSF854	1/4"	\$5.95
#SSF856	3/8"	\$5.95
#SSF858	1/2"	\$6.95

### PLUG

#SSF804	1/4"	\$3.95
#SSF806	3/8"	\$3.95
#SSF808	1/2"	\$4.95

### COUPLINGS

#SSF458	1/2"	\$4.59
#SSF462	3/4"	\$6.02

### STREET EL 90 DEGREE

#SSF604	1/4"	\$4.95
#SSF606	3/8"	\$5.95
#SSF608	1/2"	\$6.95

### ELBOW - FPT x FPT

#SSF554	1/4"	\$3.95
#SSF556	3/8"	\$4.95
#SSF558	1/2"	\$5.95
#SSF562	3/4"	\$6.95

### HEX NIPPLE

#SSF754	1/4"	\$3.95
#SSF756	3/8"	\$4.95
#SSF758	1/2"	\$5.95

### NIPPLE

#SSF712	1/4" x 2"	\$3.95
#SSF714	1/4" x 3"	\$4.95
#SSF724	3/8" x 3"	\$4.95
#SSF731	1/2" x 2"	\$4.95
#SSF733	1/2" x 3"	\$5.95

### HOSE BARBS - BARB X MPT

#SSF354	1/4" x 1/4"	\$4.95
#SSF358	3/8" x 3/8"	\$5.95
#SSF362	1/2" x 1/2"	\$7.95
#SSF368	3/4" x 3/4"	\$9.95

## FITTINGS UP TO 6,000 PSI Rust Free Zinc Plated

W/P = WORKING PRESSURE

"A" = 6,000 PSI - "B" = 5,000 PS  
"C" = 4,500 PSI - "D" = 4,000 PSI  
"E" = 3,000 PSI

### ELBOW

		W/P	
HDF506	3/8" x 3/8"	C	\$2.87
HDF508	1/2" x 1/2"	E	\$2.93
HDF512	3/4" x 3/4"	D	\$4.98

### TEE

		W/P	
HDF656	3/8"	C	\$2.98
HDF658	1/2"	E	\$3.98
HDF662	3/4"	E	\$5.98

### CROSS

		W/P	
HDF666	3/8"	C	\$4.97
HDF668	1/2"	E	\$6.98

### BUSHINGS, REDUCING

		W/P	
HDF676	3/8" x 1/4"	A	\$1.01
HDF678	1/2" x 1/4"	A	\$1.29
HDF680	1/2" x 3/8"	A	\$1.41
HDF682	3/4" x 1/2"	A	\$1.49

### PIPE NIPPLE

		W/P	
HDF804	3" x 3/8"	A	\$4.97
HDF805	4" x 3/8"	A	\$4.97
HDF807	3" x 1/2"	A	\$5.29
HDF808	4" x 1/2"	A	\$5.31
HDF810	6" x 1/2"	A	\$5.76
HDF812	3" x 3/4"	A	\$7.89
HDF814	6" x 3/4"	A	\$8.19

### COUPLER

		W/P	
HDF415	1/4" x 1/4"	A	\$1.29
HDF417	3/8" x 3/8"	A	\$1.67
HDF420	1/2" x 1/2"	B	\$1.98
HDF422	3/4" x 3/4"	B	\$2.36

### NIPPLES, HEX

		W/P	
HDF425	1/4" x 1/4"	A	\$1.01
HDF427	3/8" x 3/8"	A	\$1.23
HDF430	1/2" x 1/2"	A	\$1.42
HDF434	3/4" x 3/4"	A	\$1.96

### NIPPLES, REDUCING

		W/P	
HDF429	1/2" x 3/8"	A	\$1.70
HDF431	3/4" x 1/2"	A	\$1.98

### STREET EL

		W/P	
HDF438	1/4" x 1/4"	B	\$2.43
HDF440	3/8" x 3/8"	C	\$2.84
HDF442	1/2" x 1/2"	E	\$3.23
HDF444	3/4" x 3/4"	E	\$3.97

### STREET TEE

		W/P	
HDF684	1/4"	B	\$2.66
HDF685	3/8"	C	\$3.41
HDF686	1/2"	E	\$4.87

### BRANCH TEE

		W/P	
HDF875	1/4"	B	\$3.02
HDF776	3/8"	C	\$3.56
HDF977	1/2"	E	\$4.88



## Industrial Ball Valves

• Rated to 3,000 PSI



1669/1670



1303

- Full flow ports
- All FPT x FPT

PART #	DESCRIPTION / PRICE
1303	3/8" FxF \$19.66
1669	3/8" FxF \$32.11
1670	1/2" FxF \$39.92

## High Pressure Ball Valves to 7,500 psi

PART # DESCRIPTION / PRICE

1304	BALL VALVE, 1/4", 7,500 PSI	\$15.64
1305	BALL VALVE, 3/8", 7,500 PSI	\$17.94
1306	BALL VALVE, 1/2", 5,000 PSI	\$18.98
1467	3 WAY BALL VALVE, 5000 PSI, 1/4"	\$39.91
1468	3 WAY BALL VALVE, 5000 PSI, 3/8"	\$44.73
1469	3 WAY BALL VALVE, 5000 PSI, 1/2"	\$47.91



- Rugged carbon steel construction
- Blow-out proof stem
- Delrin® ball seats
- Buna-N® o'rings

## 3/4" GATE VALVE



• This is what the contractors use to 'shut-off' the water tank when it is full and they need to un-hook the feed hose.

PART #	DESCRIPTION / PRICE
4520	3/4" FxF \$11.73

## Stainless Steel Ball Valves - 2,000 psi

• Rated to 2,000 psi



- 2-piece, 316 stainless
- Glass filled Teflon® seats

PART #	DESCRIPTION / PRICE
2159	1/2" FxF \$15.47

## 3-Way Ball Valve

- For setting up dual chemical feeds
- Solid brass construction
- Arrow-on indicator
- All you need is 3 hose barbs and you are in the dual chemical business



PART #	DESCRIPTION / PRICE
1308	3-WAY BALL VALVE, 1/4" \$27.42

## Long Handle Mini

- Rated to 200 PSI
- Packings are chemical resistant
- Extra long handle for 'slippery' hands'



PART #	DESCRIPTION / PRICE
1075	1/4" FPT x FPT \$3.90
1084	1/4" FPT x MPT \$3.90
1122	3/8" FPT x FPT \$3.90
1125	3/8" FPT x MPT \$4.29
1134	1/2" FPT x FPT \$4.85
1147	1/2" FPT x MPT \$3.37

## Chemical Metering Ball Valve

- Solid brass construction
- MPT x 1/4" hose barb
- Can be used in conjunction with our 3-way valve to quickly meter chemicals by simply "throttling" the valve



PART #	DESCRIPTION / PRICE
1307	1/4" Barb x 1/4" MPT \$11.26

## Mini Ball Valve

- Designed for tight places
- 1 3/4" long
- Compact knob
- Rated to 220 PSI



PART #	DESCRIPTION / PRICE
1461	1/8" FxF \$2.28
1462	1/4" FxF \$8.78
1464	3/8" FxF \$8.78
1465	1/2" FxF \$9.87

## Ball Valve

6,000 PSI 316 STAINLESS



PART #	DESCRIPTION / PRICE
1666	1/4" FPT X FPT \$25.76
1667	3/8" FPT X FPT \$42.36
1668	1/2" FPT X FPT \$46.29

## 3-Way Valve 1/2" Tank/Faucet Diverter

- For use in situations where the operator will occasionally have to switch from an on-board water tank to the customers faucet.



#4535 \$21.36  
600 PSI





## Industrial Trigger Jet Spray Guns

for SHURFLO & Other Low Pressure Pumps

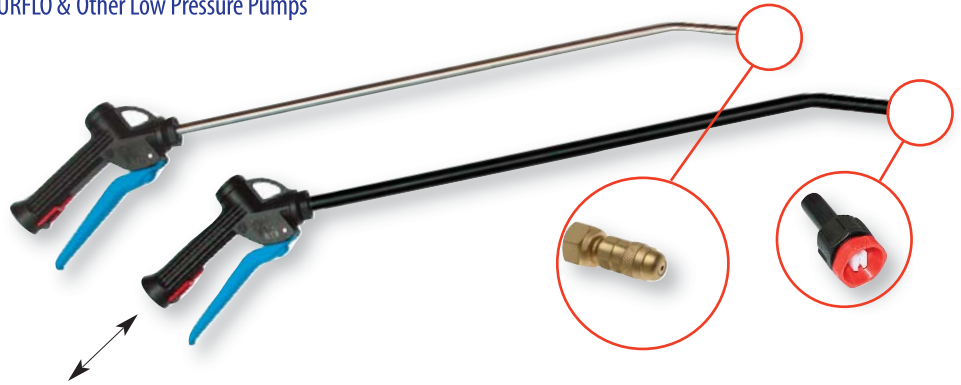

### Brass Barbs

Guns have 1/2" Inlet - so if you are using a...

...1/4" Chem Line order Brass Barb #1726

...3/8" Chem Line order Brass Barb #1727

...1/2" Chem Line order Brass Barb #1728

PART #	DESCRIPTION / PRICE
1726	BRASS BARB \$2.87
1727	BRASS BARB \$2.87
1728	BRASS BARB \$3.27



PART #	DESCRIPTION / PRICE
<b>350 PSI GUN, VITON® SEALS WITH POLY LANCE</b>	
1213	30" POLY LANCE - SS BALL - FAN NOZZLE \$19.74
3333	24" STAINLESS LANCE - ADJ NOZZLE - GRIP \$26.26
1212	TRIGGER JET SPRAY GUN- STAINLESS BALL \$16.42
1169	TRIGGER JET SPRAY GUN-CERAMIC BALL \$19.86

### Chemical Tubing

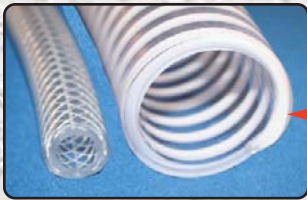

### Tank to Equipment Non-Crushable Tubing

Will not collapse in hot weather, when you accidentally set something heavy on it or when you try and 'kink' it.



- Clear Reinforced Poly Tubing which is highly resistant to chemicals, fuel & solvents
- Working pressure of 250 PSI with a burst pressure of 750 PSI

PART #	DESCRIPTION / PRICE
<b>1/4" POLYBRAID CHEMICAL TUBING - 250 Working / 750 Burst</b>	
1159	1/4" X 25' ROLL \$ 7.77
1160	1/4" X 50' ROLL \$14.34
1161	1/4" X 100' ROLL \$28.05
1162	1/4" X 300' ROLL \$80.63
<b>3/8" POLYBRAID CHEMICAL TUBING - 250 Working / 750 Burst</b>	
1163	3/8" X 25' ROLL \$ 9.90
1164	3/8" X 50' ROLL \$17.93
1165	3/8" X 100' ROLL \$34.12
1166	3/8" X 300' ROLL \$97.16
<b>1/2" POLY BRAID CHEMICAL TUBING - 250 Working / 750 Burst</b>	
2217	1/2" X 100' ROLL \$ 47.85
2637	1/2" X 300' ROLL \$128.71
<b>3/4" POLYBRAID CHEMICAL TUBING - 250 Working / 750 Burst</b>	
2483	3/4" X 100' ROLL \$ 69.60
2709	3/4" X 300' ROLL \$209.12
<b>1/4" PREMIUM CLEAR CHEMICAL LINE</b>	
1167	1/4" PREMIUM CHEM LINE, 100' \$49.75
2199	1/4" STD. CHEMICAL LINE, 100' \$19.84

### Poly Fittings

For SHURFLO & Low Pressure Pumps

- When you order a ShurFlo pump be sure and ask your sales rep for the correct poly bars.

#### STRAIGHT - Any Size \$2.77

PB14S	1/4" Barb x 1/4" MPT
PB148S	1/4" Barb x 3/8" MPT
PB38S	3/8" Barb x 3/8" MPT
PB12S	1/2" Barb x 1/2" MPT
PB34S	3/4" Barb x 3/4" MPT
PB10S	1.0" Barb x 1.0" MPT

#### 90° BEND - Any Size \$2.77

PB14B	1/4" Barb x 1/4" MPT
PB148B	1/4" Barb x 3/8" MPT
PB38B	3/8" Barb x 3/8" MPT
PB12FB	1/2" Barb x 1/2" FPT
PB12B	1/2" Barb x 1/2" MPT
PB34B	3/4" Barb x 3/4" MPT
PB10B	1.0" Barb x 1.0" MPT



### Replacement Cone Sprayer Nozzle

- Solid brass construction
- Fully adjustable
- Fits 1/4" MPT Lance

PART #	PRICE
1211	\$3.36



## DELEVAN 12 VOLT TANK & SPRAYER

WITH CHEMICAL VALVES

1 GPM @ 50 PSI



**DELEVAN**

15 Gallon Tank #1067 \$69.34

Pump, Lance, 12 Volt Leads 15' Hose #1059 \$89.17

**ORDER BOTH AND WE WILL ASSEMBLE**

PRE-DRILLED TO FIT ALL SHURFLO PUMPS ABOVE  
Shown assembled for illustration purposes only.



# SHURFLO PUMPS



**WITH CHEMICAL RESISTANCE SEALS & VALVES**

**PART # DESCRIPTION / PRICE**

**12 VOLT SHURFLO PUMPS WITH PREMIUM VALVES**

1049	1.4 GPM / 60 PSI / VITON VALVES	\$ 87.62
1050	1.8 GPM / 100 PSI / VITON VALVES	\$ 90.47
1671	ALLISON Chem Induction Pump	\$102.54
1051	3.0 GPM / 45 PSI / VITON VALVE	\$103.93
1052	3.6 GPM / 45 PSI / VITON VALVE	\$141.52
1053	1.4 GPM / 60 PSI / VITON VALVES	\$105.93
1054	1.5 GPM / 150 PSI / VITON VALVES	\$142.20
1055	1.0 GPM / 60 PSI / VITON VALVES	\$146.78
1056	1.6 GPM / 100 PSI / VITON VALVES	\$117.30

**PART # DESCRIPTION / PRICE**

**REPAIR KITS FOR SHURFLO PUMPS**

1046	CHECK VALVE - 8000 SERIES	\$19.64
1048	CHECK VALVE - 2088 SERIES	\$17.09
1041	DIAPHRAGM KIT, 8000 SERIES	\$20.15
1045	DIAPHRAGM DRIVE KIT, 2088 SERIES	\$27.94
1042	PRESSURE SWITCH, 8000, 60 PSI, VITON SERIES	\$27.32
1043	PRESSURE SWITCH, 8000, 100 PSI, VITON SERIES	\$26.52
1044	PRESSURE SWITCH, 2088, 45 PSI, VITON SERIES	\$42.98

## Pump-Up Sprayers

PART #	DESCRIPTION	PRICE
1883	PUMP-UP SPRAYER, 2.0 GAL	\$14.93
1844	BACK-PACK SPRAYER	\$39.88

4.0 Gallon, 90 PSI Backpack Sprayer  
(includes 4 nozzles)



2.0 Gallon  
Pump-Up Sprayer

## SHURFLO FITTINGS

**WINGNUT SWIVEL - STRAIGHT**

#SF01	1/2" F x 1/2" Barb	\$ 1.05
#SF02	1/2" F x 3/8" Barb	\$ 1.05
#SF03	1/2" F x 3/4" (M)	\$ 1.05



**HEX SWIVEL - STRAIGHT**

#SF04	1/2" F x 1/2" Barb	\$ 1.05
#SF05	1/2" F x 3/8" Barb	\$ 1.05



**WINGNUT SWIVEL - 90°**

#SF06	1/2" F x 5/8" Barb	\$ 1.05
#SF07	1/2" F x 3/4" Barb	\$ 1.05
#SF08	1/2" F x 1/2" Barb	\$ 1.05



**HEX SWIVEL - 90°**

#SF09	1/2" F x 3/8" Barb	\$ 1.25
#SF10	1/2" F x 1/2" Barb	\$ 1.25



On this page we pay the freight on \$50.00 Web Orders or \$200.00 Call-in Orders





## LAFFERTY HOSE END SPRAYER



Stainless Steel Hose End Sprayers.

Hose End Sprayers are machined stainless steel venturis that quick connect to the trigger gun and draw chemical from any container. Designed for pressure washers NOT equipped with a downstream chemical injector.

These applicators come with everything needed for injecting chemicals using a pressure washer.

Metering tips for accurately setting the chemical dilution ratio, quick connect fitting, tubing, and strainer are all included.

- Draw chemical concentrate from any chemical container and dilutes it to the required ratio.
- Fan pattern for quick coverage close up, remove the nozzle for distance.
- Ideal for applying stronger or more aggressive chemicals as no chemical passes through the pump, hose or trigger gun.
- Quickly change from spraying to rinsing.
- Choice of two models.

#969510	Model 10 SS Hose End Airless Sprayer	\$194.15
#969520	Model 20 SS Hose End Airless Sprayer	\$194.15

## LAFFERTY HOSE END FOAMERS



Hose End Airless Foamers are machined stainless steel venturis that quick connect to the trigger gun and draw chemical from any container. Designed for pressure washers NOT equipped with a downstream chemical injector.

These applicators come with everything needed for injecting chemicals using a pressure washer.

Metering tips for accurately setting the chemical dilution ratio, quick connect fitting, tubing, and strainer are all included.

- Draws chemical concentrate from any chemical container and dilutes it to the required ratio.
- Foam is created instantly by the stainless steel venturi airless foam wand.
- Two foam nozzles included, fan pattern for quick - Ideal for applying stronger or more aggressive chemicals as no chemical passes through the pump, hose or trigger gun.
- Quickly change from foaming to rinsing.
- Foam throw up to 30 ft.
- Choice of two models

#969610	Model 10 SS Hose End Airless Foamer	\$229.77
#969620	Model 20 SS Hose End Airless Foamer	\$229.77

## LAFFERTY FOAM WAND



Airless Foam Wands are machined venturis that draw in atmospheric air to produce wet clinging foam. Designed for pressure washers that are already equipped with a downstream chemical injector.

- Thick foam is created instantly by the stainless steel venturi airless foam wand
- Foam throw up to 35 ft.
- MINIMUM 4.0 GPM Required
- Recommended Injector: Super Suds Sucker

#969400	4.0 Stainless Steel, Airless Foamer	\$109.77
#969410	4.5 Stainless Steel, Airless Foamer	\$109.77

## LAFFERTY FOAMER SPRAYER KITS



Offering convenient versatility, Combo Airless Foamer / Sprayer Kits are machined stainless steel venturi injectors that quick connect to the discharge of the pump and include a venturi foam wand and a spray nozzle that quick connect to the trigger gun.

Designed for pressure washers NOT equipped with a downstream chemical injector. These kits come with everything needed for injecting chemicals using a pressure washer. Metering tips for accurately setting the chemical dilution ratio, quick connect fittings, clear tubing, and strainer are all included

- The injector draws chemical concentrate from any chemical container and dilutes it to the required ratio.
- Select the stainless steel airless foam wand to instantly create wet clinging foam.
- Select the stainless steel spray nozzle to spray non foaming chemicals.
- Two foam nozzles included, fan pattern for quick coverage close up and zero degree for distance.
- Ideal for applying stronger or more aggressive chemicals as no chemical passes through the pump.
- Chemical concentrates can be dispensed from original containers.
- Foam throw up to 30 ft.
- Choice of two models.

#969710	Model 10 SS Combo Airless Foamer	\$296.06
#969720	Model 20 SS Combo Airless Foamer	\$296.06

## High Pressure Foam Cannon



- Throws thick foam for deep cleaning
- Works on systems up to 6.6 GPM
- Rated to 3,000 PSI
- Order with or without bottle

PART #	DESCRIPTION / PRICE
1272	CANNON, NO BOTTLE \$46.37
1273	CANNON W/ TANK \$49.12



## Premium High Volume Filter

Used on Allison Iron Horse Equipment!  
We recommend that you use this filter on all equipment over 8 GPM.

### THE INDUSTRY'S ABSOLUTE BEST FILTER

- Extra large internal chamber
- Extra large ports for maximum flow
- Handles up to 22 GPM
- 50 mesh screen, 1" inlet/outlet



PART #	DESCRIPTION / PRICE
1015	PREMIUM WATER FILTER \$33.62

For more information about water filters look in the TECHNICAL SECTION of our Website at <http://www.envirospec.com>

## Clear Bowl Water Filter

- 50 mesh filtration
- Heavy duty molded plastic
- Viewable filter media



PART #	DESCRIPTION / PRICE
1012	CLEAR BOWL FILTER, 1/2" In/Out \$11.86
1013	CLEAR BOWL FILTER, 3/4" In/Out \$11.86

## Direct Mount Water Filter

- Clear view filter mounts directly to pump
- Built-in garden hose connector
- Easily disassembles for cleaning
- Solid brass construction



PART #	DESCRIPTION / PRICE
1010	DIRECT MOUNT FILTER W/O BYPASS \$8.16
1011	DIRECT MOUNT FILTER W/ BYPASS \$8.83

## SUR-TRAP-Y-Trap Strainer

- Solid brass body & cap
- 50 mesh, stainless screen
- Rated to 175 PSI & 195°F



PART #	DESCRIPTION / PRICE
1155	SUR-TRAP, Y-TRAP STRAINER, 3/8" \$4.17
1156	SUR-TRAP, Y-TRAP STRAINER, 1/2" \$7.62
1157	SUR-TRAP, Y-TRAP STRAINER, 3/4" \$9.87
1158	SUR-TRAP, Y-TRAP STRAINER, 1" \$9.87

## Compact Water Filter

- Flows to 6 GPM / pressure to 150 PSI
- 50 mesh filter screen, aluminum housing
- Die-cast metal housing with plastic cap
- 1/2" FPT inlet / MPT outlet
- 2 1/4" by-pass ports



PART #	DESCRIPTION / PRICE
1009	COMPACT WATER FILTER \$9.76

## Garden Hose Quick Connects

- Industrial Quality
- Solid Brass Construction



PART #	DESCRIPTION / PRICE
1016	QUICK CONNECT PLUG \$2.07
1017	QUICK CONNECT COUPLER \$2.64
1018	QUICK CONNECT, COMPLETE SET \$4.21

## Garden Hose Connectors

- 3/4" FPT inlet
- MPT outlet filter connector
- Solid brass construction



PART #	DESCRIPTION / PRICE
1019	CONNECTOR, GARDEN HOSE 1/2" \$3.94
1020	CONNECTOR, GARDEN HOSE 3/4" \$4.62
1625	WASHER SCREEN, GARDEN HOSE \$0.21

## Remote Filter Hanger

This Filter Mounting Hanger can be frame mounted, wall mounted or floor mounted.

It comes with a 1" Hose Barb and a 1" HEX Nipple and will accommodate any 1" In/Out Filter



- Handles up to a 1" Filter
- Mount to floor, ceiling, wall or frame
- Shown with optional Premium High Volume Filter

PART #	DESCRIPTION / PRICE
2412	Remote Filter Hanger \$19.84

## Garden Hose Connectors

Includes Garden Hose Connector



PART #	DESCRIPTION / PRICE
1309	SHUT OFF, SINGLE GARDEN HOSE \$3.45
1310	SHUT OFF, DUAL GARDEN HOSE \$4.12
1311	DUAL GARDEN HOSE CONNECTOR \$1.67

## FIRE HYDRANT HOSE

- Fill that 500 Gallon Tank in 2 Minutes Flat!
- Complete with MxN NST Aluminum Connector
- Use PVC Pipe on the Tank End



PART #	DESCRIPTION / PRICE
3336	50' x 2-1/2" \$284.60





## PIVOTING LANCE

JUST TWIST THE HANDLE!

- #2040 28" \$52.68
- #2041 41" \$59.84
- #2042 51" \$68.78



**Head Pivots 90°**  
Direct power where you need it every time.

## Lance Couplers

- Keeps lances from breaking at thread level.
- The stabilizing shoulder is recessed deep into the coupling before the thread starts.



PART #	DESCRIPTION / PRICE
1021	PLUG, PLATED 1/4" FPT \$1.91
1022	COUPLER, PLATED 1/4" FPT \$3.66
1023	PLUG, STAINLESS 1/4" FPT \$3.41
1024	COUPLER, STAINLESS 1/4" FPT \$6.81
1258	DEEP SHOULDER COUPLING \$.99

## SPRAY-FLEX Lances

- Holds Shape up to 5000 PSI



PART #	DESCRIPTION / PRICE
1691	Rated to 3,000 PSI \$47.77
1692	Rated to 5,000 PSI \$52.77

## Side Handle & Grip

These grips fit all 1/4" lances without molded grips as well as any 1/4" pipe.



PART #	DESCRIPTION / PRICE
1260	ADJ. SIDE HANDLE \$3.93
1612	VENTED GRIP \$5.17

## Flex Lances

- Flexes 180° and returns.
- Great for wheel wells on autos.
- 18" long x 1/4" MPT in & out on plated steel.
- 1/4" MPT In & 1/4" FPT out on stainless.
- Max pressure 2,500 PSI



PART #	DESCRIPTION / PRICE
1795	PLATED STEEL \$ 9.82
1796	STAINLESS STEEL \$19.01

## Gutter Sweep

- 12" gutter cleaner • 1/4" QC connectors

"Attach it to the end of your lance, snap in your favorite nozzle, position it over the gutter ...and pull the trigger!"



PART #	DESCRIPTION / PRICE
1814	W/Standard Quick Connects \$ 6.16
1815	W/Twist Fast QC Inlet \$15.84

## Lance Hangers

- Keep lances off the floor



PART #	DESCRIPTION / PRICE
3612	Rated to 3,000 PSI \$3.88
3613	Rated to 5,000 PSI \$3.88

## Schedule 80 Aluminum Lances



96" lances are sold with 2 each, 48" sections with a special lance coupler



PART #	DESCRIPTION / PRICE
<b>WITH GRIPS &amp; 1/4" MPT INLET/OUTLET</b>	
1354	24" LANCE W/ROUND GRIP \$ 8.40
1356	36" LANCE W/VENT GRIP \$10.16
1358	48" LANCE W/VENT GRIP \$11.89
1360	60" LANCE W/VENT GRIP \$12.91
1364	96" LANCE W/VENT GRIP \$18.86
<b>WITHOUT GRIPS &amp; 1/4" MPT INLET/OUTLET</b>	
1353	24" LANCE - NO GRIP \$ 4.98
1355	36" LANCE - NO GRIP \$ 6.91
1357	48" LANCE - NO GRIP \$ 7.74
1359	60" LANCE - NO GRIP \$ 8.63
1361	72" LANCE - NO GRIP \$10.18
1363	96" LANCE - NO GRIP \$16.12

## Stainless & Plated Lances

- \* SPECIAL PURCHASE
- \* Industry's Best Lance!
- \* Industry's Best Price!

All Lances have Grips  
1/4 MPT In/Out

PART #	DESCRIPTION / PRICE
<b>PLATED - 1/4" MPT IN/OUT</b>	
1236	STRAIGHT, 12" \$ 4.79
1237	STRAIGHT, 24" \$ 5.90
1238	STRAIGHT, 36" \$ 6.82
1242	15° BENT, 36" \$ 9.63
1239	<b>STRAIGHT, 48" \$ 2.90 *</b>
1243	15° BENT, 48" \$15.62
1240	<b>STRAIGHT, 60" \$ 3.12 *</b>
1244	15° BENT, 60" \$18.81
1241	<b>STRAIGHT, 79" \$ 3.88 *</b>
1245	15° BENT, 79" \$23.07
<b>S.S. VENTED GRIP - 1/4" MPT IN/OUT</b>	
1246	STRAIGHT, 24" \$ 9.81
1247	STRAIGHT, 36" \$15.60
1251	15° BENT, 36" \$19.91
1248	STRAIGHT, 48" \$21.57
1252	15° BENT, 48" \$24.44
1249	STRAIGHT, 60" \$24.80
1253	15° BENT, 60" \$26.90
1250	STRAIGHT, 79" \$29.97
1254	15° BENT, 79" \$33.38





## Zinc Lance with Diverter Trigger

- Nozzle Protector
- Pull the Trigger to Draw Soap
- Release the Trigger for High Pressure
- 1/4" MPT inlet - 1/8" discharge pipes

- **TEMP:** 300°F
- **GPM:** 10.5
- **PSI:** 3,600



PART #	PRICE
1235	\$49.63

## Premium Series Stainless

- 1/4" MPT inlet
- 1/4" outlets for more Chem Draw



**STAINLESS - FOR HIGHLY CORROSIVE ENVIRONMENTS**

PART #	DESCRIPTION / PRICE
1263	11" STAINLESS STEEL \$38.62
1264	27" STAINLESS STEEL \$44.19
1265	37" STAINLESS STEEL \$39.97
1262	42" STAINLESS STEEL \$43.39 <b>BEST BUY</b>
<b>NEW</b> 1362	42" ZINC PLATED \$31.30 <b>BEST BUY</b>

- **TEMP:** 300°F
- **GPM:** 10.5
- **PSI:** 4,100

"1263" attach to gun for "close quarter" work such as car lots.

## Dual Lances

new 'deluxified' ready-to-go Lances

- Zinc-Plated Steel
- General/InterPump Brand
- 1/4" MPT inlet - 1/8" discharge pipes



36" Dual Lance, Zinc-Plated Steel with "Quick Connects" installed for pressure & soap nozzle.....Part #1256

PART #	DESCRIPTION / PRICE
1255	36" \$54.93
1256	36", w/"QCs" \$59.96
1257	72" \$68.84

- **TEMP:** 284°F
- **GPM:** 10.5
- **PSI:** 3,000

## Telescoping 'Long Wands'

**RATED TO 4,000 PSI**



PART #	DESCRIPTION / PRICE
2024	3 Section to 24' with 3/8" Hose \$103.18
2029	Replacement Gun fits 2024 \$ 24.30
1815	Gutter Sweep with Twist Type Connects \$ 15.84
2028	'Load Bearing' Belt / Harness \$ 7.87



#1815

## Performance Nozzle for Telescoping Wands

"PUSH" for Soap "Pull" for Pressure

- Quickly attaches to the telescoping wand to increase the chemical application distance by 25 feet & the wash/rinse distance by 40 feet.
- You can apply chemical from 0-65 degrees and rinse from 0-65 degrees without changing the nozzle.
- The 45 degree angle also helps support over 60% of the lance weight when trigger is pulled.



PART #	DESCRIPTION / PRICE
1347	3.5 Nozzle Size, 4,100 PSI, 190° \$28.39
1365	4.0 Nozzle Size, 4,100 PSI, 190° \$28.39
1424	4.5 Nozzle Size, 4,100 PSI, 190° \$28.39
1440	5.0 Nozzle Size, 4,100 PSI, 190° \$28.39
1466	5.5 Nozzle Size, 4,100 PSI, 190° \$28.39
1470	6.0 Nozzle Size, 4,100 PSI, 190° \$28.39
1590	6.5 Nozzle Size, 4,100 PSI, 190° \$28.39
1594	7.0 Nozzle Size, 4,100 PSI, 190° \$28.39
1623	8.0 Nozzle Size, 4,100 PSI, 190° \$28.39



Replacement Gun



2028



# Our Most Popular Industrial Hose Reel

The Industry's Best Hose Reel Value!

They're Rugged!

**We Pay Freight on these REELS**

Solid Steel Construction, Durable Powder Coat, Direct Hand Crank rewind, Full Flow Swivel Brass Joint, 5,000 PSI Rated, 3-1 Burst Factor



PART #	DESCRIPTION / PRICE	
1313	HOLDS 50' of 3/8" 1-wire	\$51.93
1314	HOLDS 100' of 3/8" 1-wire	\$59.97
1315	HOLDS 150' of 3/8" 1-wire	\$71.66
1316	HOLDS 200' of 3/8" 1-wire	\$79.98
REPLACEMENT SWIVELS		
1008	SWIVEL, FITS #1313 & 1314	\$17.04
1001	SWIVEL, FITS #1315 & 1316	\$17.04
REPLACEMENT HANDLE		
1002	REPLACEMENT HANDLE	\$ 7.33

## M-Series Compact Mini Hose Reel

- Only 14.5" tall
- Fully adjustable brake
- Heavy duty ABS bearings require no lubrication
- This reel is ideally suited to fit into tight space applications

• 7-10 DAY BUILD TIME

PART #	DESCRIPTION	
1862	HOLDS 75' 3/8" or 50' 1/2"	\$220.34
1857	HOLDS 150' 3/8" or 100' 1/2"	\$231.38



## E-Series 12V Electric Hose Reel

- 12 V DC motor driven
  - Self lubricating ABS bearings
  - Motor sprocket & chain pinch points are safe guarded
  - Brass swivel reduces corrosion
- 7-10 Day Build Time, Must ship freight lines

PART #	DESCRIPTION	
1782	HOLDS 350' 3/8" or 275' 1/2"	\$494.34
1783	HOLDS 450' 3/8" or 375' 1/2"	\$532.92
1784	HOLDS 550' 3/8" or 475' 1/2"	\$551.09

## M-Series Manual Hose Reel

- Hosetract industrial hose reels offer a durable and simple design.
- Self lubricating ABS bearings.
- Adjustable brake-adjust tension with hand knob.
- Heavy duty brass swivel to reduce corrosion potential.

• 7-10 DAY BUILD TIME



PART #	DESCRIPTION	
1861	HOLDS 100' 3/8" or 75' 1/2"	\$192.12
1856	HOLDS 250' 3/8" or 175' 1/2"	\$226.62
1858	HOLDS 350' 3/8" or 275' 1/2"	\$251.92
1859	HOLDS 450' 3/8" or 375' 1/2"	\$272.20
1860	HOLDS 550' 3/8" or 475' 1/2"	\$310.79
STAINLESS STEEL		
1868	HOLDS 100' 3/8" or 75' 1/2"	\$375.07
1864	HOLDS 250' 3/8" or 175' 1/2"	\$395.12
1865	HOLDS 350' 3/8" or 275' 1/2"	\$411.57
1866	HOLDS 450' 3/8" or 375' 1/2"	\$430.21
1867	HOLDS 550' 3/8" or 475' 1/2"	\$467.11

## Stackable Frame Hose Reel

- Stack capability with no added parts needed
  - Self lubricating ABS bearings
  - Adjustable brake - adj, tension w/hand knob
  - HD - 4,000 PSI swivel for longer service
  - Part number represents one reel
- 7-10 DAY BUILD TIME



## HOSETRACT

PART #	DESCRIPTION	
1948	STACKER, HOLDS 250' 3/8" or 175' 1/2"	\$253.35
1949	STACKER, HOLDS 350' 3/8" or 275' 1/2"	\$265.31
1950	STACKER, HOLDS 450' 3/8" or 375' 1/2"	\$292.18
1951	STACKER, HOLDS 550' 3/8" or 475' 1/2"	\$311.10
STAINLESS STEEL		
1952	STACKER, HOLDS 250' 3/8" or 175' 1/2"	\$437.26
1953	STACKER, HOLDS 350' 3/8" or 275' 1/2"	\$482.06
1954	STACKER, HOLDS 450' 3/8" or 375' 1/2"	\$485.22
1955	STACKER, HOLDS 550' 3/8" or 475' 1/2"	\$491.91

You Pay Freight on HOSETRACT we Pay Freight on the Industrial Reel up top



# SERPENTINE PRESSURE WASH HOSE

## THE INDUSTRY'S #1 SELLING HOSE!

OUR 4, 5 & 6,000 HOSES WORK HARDER & WEIGH LESS THAN THEIR 3,000, 4,500 & 5800 PSI  
***AND LASTS MUCH LONGER!***

- Super tough cover design
- 1 ea. 3/8" MPT swivel end
- 1 ea. 3/8" MPT fixed end
- Temperature to 250°F
- Tough wrapped outer cover
- Strain reliefs on both ends



50' 4000 BLACK  
 1 Wire - 3/8"  
 Swivel x Fixed Ends  
 1708 \$49.95

100' 4000 BLACK  
 1 Wire - 3/8"  
 Swivel x Fixed Ends  
 1709 \$89.95

50' 4000 BLACK  
**w/Quick Connects**  
 1 Wire - 3/8"  
 Swivel x Fixed Ends  
 Q1708 \$59.95

100' 4000 BLACK  
**w/Quick Connects**  
 1 Wire - 3/8"  
 Swivel x Fixed Ends  
 Q1709 \$99.95

50' 4000 GREY  
 1 Wire - 3/8"  
 Swivel x Fixed Ends  
 1804 \$59.95

100' 4000 GREY  
 1 Wire - 3/8"  
 Swivel x Fixed Ends  
 1805 \$99.95

50' 4000 GREY  
**w/Quick Connects**  
 1 Wire - 3/8"  
 Swivel x Fixed Ends  
 Q1804 \$69.95

100' 4000 GREY  
**w/Quick Connects**  
 1 Wire - 3/8"  
 Swivel x Fixed Ends  
 Q1805 \$109.95

50' 6000 BLACK  
 2 Wire - 3/8"  
 Swivel x Fixed Ends  
 6001 \$66.95

100' 6000 BLACK  
 2 Wire - 3/8"  
 Swivel x Fixed Ends  
 6002 \$129.95

50' 6000 BLACK  
**w/Quick Connects**  
 2 Wire - 3/8"  
 Swivel x Fixed Ends  
 Q6001 \$76.95

100' 6000 BLACK  
**w/Quick Connects**  
 2 Wire - 3/8"  
 Swivel x Fixed Ends  
 Q6002 \$139.95

50' 6000 GREY  
 2 Wire - 3/8"  
 Swivel x Fixed Ends  
 6101 \$76.95

100' 6000 GREY  
 2 Wire - 3/8"  
 Swivel x Fixed Ends  
 6102 \$139.95

50' 6000 GREY  
**w/Quick Connects**  
 2 Wire - 3/8"  
 Swivel x Fixed Ends  
 Q6101 86.95

100' 6000 GREY  
**w/Quick Connects**  
 2 Wire - 3/8"  
 Swivel x Fixed Ends  
 Q6102 \$149.95

### RE-USABLE HOSE ENDS

• For temporary repairs



1191	1 WIRE, 3/8", FIXED	\$12.16
1192	1 WIRE, 3/8", SWIVEL	\$16.82
1193	2 WIRE, 3/8", FIXED	\$13.73
1194	2 WIRE, 3/8", SWIVEL	\$17.87

PART #	DESCRIPTION	
1202	1' WHIP/JUMPER	\$ 6.95
1172	2' JUMPER HOSE	\$ 7.95
1173	3' JUMPER HOSE	\$ 9.91
1174	4' JUMPER HOSE	\$11.07
1175	5' JUMPER HOSE	\$11.87
1176	6' JUMPER HOSE	\$12.82
1177	7' JUMPER HOSE	\$14.46
1178	8' JUMPER HOSE	\$15.23
1179	9' JUMPER HOSE	\$16.72
1180	10' JUMPER HOSE	\$17.04

## "Jumper Hose" Machine To Reel



Connects Equipment to the Reel  
 Rated to over 4400 PSI  
 One Swivel End and One Fixed End

PART #	DESCRIPTION	
1181	11' JUMPER HOSE	\$17.94
1182	12' JUMPER HOSE	\$18.86
1183	13' JUMPER HOSE	\$19.24
1184	14' JUMPER HOSE	\$19.99
1185	15' JUMPER HOSE	\$20.80
1186	16' JUMPER HOSE	\$21.42
1187	17' JUMPER HOSE	\$21.94
1188	18' JUMPER HOSE	\$22.70
1189	19' JUMPER HOSE	\$23.81
1190	20' JUMPER HOSE	\$25.59



# PREMIUM ROTATING SEWER NOZZLES

**NOT THE CHEAP STUFF!**

**PSI: 3,000 PSI**

Rotating 0°  
Front Laser Nozzle



PART #	DESCRIPTION	
1760	ROTATING NOZZLE, 1/8" FPT, 5.5 Noz	\$ 5.98
1754	ROTATING NOZZLE, 1/4" FPT, 5.5 Noz	\$ 6.32
2282	ROTATING NOZZLE, 1/4" FPT, 8.0 GPM	\$29.90

# SEWER JETTING NOZZLES - Fixed



PART #	Penetrator Nozzles	
2080	1/8" NPT / 4.0 / 3 Back 1 Front	\$5.25
2081	1/8" NPT / 5.0 / 3 Back 1 Front	\$5.25
2082	1/8" NPT / 5.5 / 3 Back 1 Front	\$5.25
2083	1/8" NPT / 6.0 / 3 Back 1 Front	\$5.25
2084	1/4" NPT / 4.5 / 3 Back 1 Front	\$5.25
2085	1/4" NPT / 5.5 / 3 Back 1 Front	\$5.25
2086	1/4" NPT / 6.5 / 3 Back 1 Front	\$5.25
2087	1/4" NPT / 7.0 / 3 Back 1 Front	\$5.25
2088	1/4" NPT / 8.0 / 3 Back 1 Front	\$5.25
2094	1/4" NPT / 9.5 / 3 Back 1 Front	\$5.25
2089	1/4" NPT / 12.0 / 3 Back 1 Front	\$5.25
2090	3/8" NPT / 4.5 / 3 Back 1 Front	\$5.25
2091	3/8" NPT / 5.5 / 3 Back 1 Front	\$5.25
2092	3/8" NPT / 6.5 / 3 Back 1 Front	\$5.25
2093	3/8" NPT / 8.0 / 3 Back 1 Front	\$5.25
9095	3/8" NPT / 12.0 / 3 Back 1 Front	\$5.25



# PREMIUM SEWER JETTING HOSE

- 3,000 PSI Thermo-plastic covering
- Maximum flexibility & very lightweight

**PART # DESCRIPTION**

**1/4" Hose with 1/4" MPT x 1/8" MPT**

1318	50' BLACK, 3,000 PSI	\$ 79.45
1319	100' BLACK, 3,000 PSI	\$137.75
1320	150' BLACK, 3,000 PSI	\$186.74
1321	200' BLACK, 3,000 PSI	\$233.15
1322	250' BLACK, 3,000 PSI	\$296.75
1323	300' BLACK, 3,000 PSI	\$349.75

**1/8" Hose with 1/4" MPT x 1/8" MPT**

1324	50' BLACK, 3,000 PSI	\$ 74.14
1325	100' BLACK, 3,000 PSI	\$116.55
1326	150' BLACK, 3,000 PSI	\$150.70
1327	200' BLACK, 3,000 PSI	\$190.75
1328	250' BLACK, 3,000 PSI	\$236.74

# WATER / CHEMICAL APPLICATION HOSE

**800 PSI**

- Will not collapse on reels
- Incredible bend radius without 'kinking'
- Safety Orange



PART #	DESCRIPTION	
3399	3/8" ID, 800 PSI, Price Per Foot	\$1.01
3400	1/2" ID, 800 PSI, Price Per Foot	\$1.17
3401	3/4" ID, 800 PSI, Price Per Foot	\$3.89

# Stainless Steel Premium Swivel

- 4,100 PSI Working
- 16,000 PSI Burst
- Up to 10.5 GPM
- 200 Degrees



*Built for the Long Haul!*

Coupler included to attach to 1/2" MPT reel inlet.

PART #	DESCRIPTION / PRICE	
1630	STAINLESS STEEL PREMIUM SWIVEL	\$49.89
1629	REPAIR KIT	\$ 9.81

# Heavy Duty Premium Swivel

- FPT x FPT
- 3/8" FPT inlet for hose
- 1/2" outlet mounts to reel



PART #	DESCRIPTION / PRICE	
1591	HD PREMIUM 5,000 PSI	\$27.76
1592	HD PREMIUM 7,000 PSI	\$39.88
1593	REPAIR KIT FOR 1592	\$11.94

# Super Swivel Hose Reel Swivel

- 5,000 PSI
- Grease Fitting for extended life
- FPT x FPT configuration
- When using 3/8" hose order P/N 1463



PART #	DESCRIPTION / PRICE	
1463	HOSE REEL SWIVEL, 3/8" X 1/2"	\$32.88
2331	HOSE REEL SWIVEL, 1/2" X 1/2"	\$32.88
1611	REPAIR KIT	\$11.16

On this page we pay the freight on \$50.00 Web Orders or \$200.00 Call-in Orders



## PREMIUM BRUSHES

PART #	PREMIUM VEHICLE & HOUSE BRUSH	PRICE
1451	10" Truck Wash	\$ 9.87
1450	10" Premium Truck & House	\$13.96
1454	14" Premium	\$14.87
1455	14" Fine Finish	\$18.78
1452	18" Truck Wash	\$17.91
1453	24" Truck Wash	\$19.93
1456	Bi-Level, 10", Hi-Pile Green	\$18.71
1457	Bi-Level, 10", Standard Yellow	\$14.22
1459	Gutter & Exhaust Stack Brush	\$21.70
1458	Bi-Directional Brush - 1/2 Circle	\$27.86
1445	Rotating Brush	\$31.16

Premium & Detail



Bi-Level Brush



10", 18" & 24"



1/2" Circle



Gutter/Stack Brush



Rotating Brush

## 5-Gal Certified Cans



RED - FLAMMABLES  
#6600 \$52.68

YELLOW - DIESEL  
#6602 \$52.68

BLUE - KEROSENE  
#6601 \$52.68



## 55 Gallon Drum Siphon Pump

- The industry's #1 selling pump
- Each will pump up to 7 GPM
- Cut down to fit 5 gallon pails



## Drum Funnel and Cover

Fits both 55 and 30 gallon drums with any 2" NPT bung.

The optional cover keeps out dirt and contamination.

PART #	DESCRIPTION / PRICE
1650	SIPHON PUMP, HEAVY DUTY \$11.92
1781	SIPHON PUMP, EXTREME DUTY \$16.88

## Drum Lids

- Keeps out dirt and contaminants.



PART #	DESCRIPTION / PRICE
6603	COVER FOR CLOSED HEAD DRUM \$15.21
6604	COVER FOR OPEN HEAD DRUM \$15.21



PART #	DESCRIPTION / PRICE
2660	FUNNEL - Less Cover \$49.88
2664	COVER \$21.92

## "Lid-Off" Pail Lid Remover

- Safely remove lids from buckets



PART #	DESCRIPTION / PRICE
1652	PAIL LID REMOVER \$19.97



# CERAMIC NOZZLES LAST 10 TIMES LONGER *than Stainless Steel!*

## CUTS LIKE A RAZOR!



**STAINLESS AFTER  
50 HOURS**

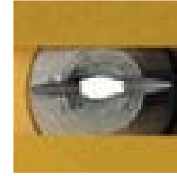

**CERAMIC AFTER  
50 HOURS**



**Quick Connect Ceramic Nozzles \$7.23**

**1/4" Threaded Ceramic Nozzles \$4.98**

NOZ.	'0' Degree	'15' Degree	'25' Degree	'40' Degree
3.0	NOQC-0003	NOQC-1503	NOQC-2503	NOQC-4003
3.5	NOQC-0003.5	NOQC-1503.5	NOQC-2503.5	NOQC-4003.5
4.0	NOQC-0004	NOQC-1504	NOQC-2504	NOQC-4004
4.5	NOQC-0004.5	NOQC-1504.5	NOQC-2504.5	NOQC-4004.5
5.0	NOQC-0005	NOQC-1505	NOQC-2505	NOQC-4005
5.5	NOQC-0005.5	NOQC-1505.5	NOQC-2505.5	NOQC-4005.5
6.0	NOQC-0006	NOQC-1506	NOQC-2506	NOQC-4006
7.0	NOQC-0007	NOQC-1507	NOQC-2507	NOQC-4007
8.0	NOQC-0008	NOQC-1508	NOQC-2508	NOQC-4008
10.0	NOQC-0010	NOQC-1510	NOQC-2510	NOQC-4010

NOZ.	'0' Degree	'15' Degree	'25' Degree	'40' Degree
3.0	NOC-0003	NOC-1503	NOC-2503	NOC-4003
3.5	N/A	NOC-1503.5	NOC-2503.5	NOC-4003.5
4.0	NOC-0004	NOC-1504	NOC-2504	NOC-4004
4.5	NOC-0004.5	NOC-1504.5	NOC-2504.5	NOC-4004.5
5.0	NOC-0005	NOC-1505	NOC-2505	NOC-4005
5.5	NOC-0005.5	NOC-1505.5	NOC-2505.5	NOC-4005.5
6.0	NOC-0006	NOC-1506	NOC-2506	NOC-4006
7.0	NOC-0007	NOC-1507	NOC-2507	NOC-4007
8.0	NOC-0008	NOC-1508	NOC-2508	NOC-4008
10.0	NOC-0010	NOC-1510	NOC-2510	NOC-4010

### NOZZLE CHART

NOZZLE SIZE	ORIFICE DIA.	40 PSI	100 PSI	250 PSI	500 PSI	600 PSI	700 PSI	800 PSI	1000 PSI	1200 PSI	1500 PSI	2000 PSI	2500 PSI	3000 PSI	3500 PSI	4000 PSI	5000 PSI
2	.034	0.20	0.32	0.50	0.71	0.77	0.84	0.89	1.00	1.10	1.22	1.41	1.58	1.73	1.87	2.00	2.24
2.5	.039	0.25	0.40	0.63	0.88	0.97	1.05	1.12	1.25	1.37	1.53	1.77	1.98	2.17	2.34	2.50	2.80
3	.043	0.30	0.47	0.75	1.06	1.16	1.25	1.34	1.50	1.64	1.84	2.12	2.37	2.60	2.81	3.00	3.35
3.5	.048	0.35	0.55	0.88	1.24	1.36	1.46	1.57	1.75	1.92	2.14	2.47	2.77	3.03	3.27	3.50	3.91
4	.052	0.40	0.63	1.00	1.41	1.55	1.67	1.79	2.00	2.19	2.45	2.83	3.16	3.46	3.74	4.00	4.47
4.5	.055	0.45	0.71	1.13	1.59	1.74	1.88	2.01	2.25	2.46	2.76	3.18	3.56	3.90	4.21	4.50	5.03
5	.057	0.50	0.79	1.25	1.77	1.94	2.09	2.24	2.50	2.74	3.06	3.54	3.95	4.33	4.68	5.00	5.59
5.5	.060	0.55	0.87	1.38	1.94	2.13	2.30	2.46	2.75	3.01	3.37	3.89	4.35	4.76	5.14	5.50	6.15
6	.062	0.60	0.95	1.50	2.12	2.32	2.51	2.68	3.00	3.29	3.67	4.24	4.74	5.20	5.61	6.00	6.71
6.5	.064	0.65	1.03	1.63	2.30	2.52	2.72	2.91	3.25	3.56	3.98	4.60	5.14	5.63	6.08	6.50	7.27
7	.067	0.70	1.11	1.75	2.47	2.71	2.93	3.13	3.50	3.83	4.29	4.95	5.53	6.06	6.55	7.00	7.83
7.5	.070	0.75	1.19	1.88	2.65	2.90	3.14	3.35	3.75	4.11	4.59	5.30	5.93	6.50	7.02	7.50	8.39
8	.072	0.80	1.26	2.00	2.83	3.10	3.35	3.58	4.00	4.38	4.90	5.66	6.32	6.93	7.48	8.00	8.94
8.5	.074	0.85	1.34	2.13	3.01	3.29	3.56	3.80	4.25	4.66	5.21	6.01	6.72	7.36	7.95	8.50	9.50
9	.076	0.90	1.42	2.25	3.18	3.49	3.76	4.02	4.50	4.93	5.51	6.36	7.12	7.79	8.42	9.00	10.06
9.5	.078	0.95	1.50	2.38	3.36	3.68	3.97	4.25	4.75	5.20	5.82	6.72	7.51	8.23	8.89	9.50	10.62
10	.080	1.00	1.58	2.50	3.54	3.87	4.18	4.47	5.00	5.48	6.12	7.07	7.91	8.66	9.35	10.00	11.18
11	.083	1.10	1.74	2.75	3.89	4.26	4.60	4.92	5.50	6.02	6.74	7.78	8.70	9.53	10.29	11.00	12.30
12	.087	1.20	1.90	3.00	4.24	4.65	5.02	5.37	6.00	6.57	7.35	8.49	9.49	10.39	11.22	12.00	13.42
12.5	.089	1.25	1.98	3.13	4.42	4.84	5.23	5.59	6.25	6.85	7.65	8.84	9.88	10.83	11.69	12.50	13.98
13	.091	1.30	2.06	3.25	4.60	5.03	5.44	5.81	6.50	7.12	7.96	9.19	10.28	11.26	12.16	13.00	14.53
14	.093	1.40	2.21	3.50	4.95	5.42	5.86	6.26	7.00	7.67	8.57	9.90	11.07	12.12	13.10	14.00	15.65
15	.096	1.50	2.37	3.75	5.30	5.81	6.27	6.71	7.50	8.22	9.19	10.61	11.86	12.99	14.03	15.00	16.77
20	.109	2.00	3.16	5.00	7.07	7.75	8.37	8.94	10.00	10.95	12.25	14.14	15.81	17.32	18.71	20.00	22.36
25	.125	2.50	3.95	6.25	8.84	9.68	10.46	11.18	12.50	13.69	15.31	17.68	19.76	21.65	23.39	25.00	27.95
30	.141	3.00	4.74	7.50	10.61	11.62	12.55	13.42	15.00	16.43	18.37	21.12	23.72	25.98	28.06	30.00	33.54
40	.156	4.00	6.32	10.00	14.14	15.49	16.73	17.89	20.00	21.91	24.49	28.28	31.62	34.64	37.42	40.00	44.72
50	.172	5.00	7.91	12.50	17.68	19.36	20.92	22.36	25.00	27.39	30.62	35.36	39.53	43.30	46.77	50.00	55.90
60	.188	6.00	9.49	15.00	21.21	23.24	25.10	26.83	30.00	32.86	36.74	42.43	47.43	51.96	56.12	60.00	67.08

GPM



# PREMIUM NOZZLES

Stainless Steel



**ALL SIZES \$2.69**

These are 1/4" Male Pipe Thread Nozzles  
If you require 1/8" nozzles, please change  
the part number to read as follows:  
'NOS8- \_\_\_\_'

## HIGH PRESSURE, QUICK CONNECT

NOZ SIZE	0°	15°	25°	40°
2.0	LQ-0002	LQ-1502	LQ-2502	LQ-4002
2.5	LQ-0002.5	LQ-1502.5	LQ-2502.5	LQ-4002.5
3.0	LQ-0003	LQ-1503	LQ-2503	LQ-4003
3.5	LQ-0003.5	LQ-1503.5	LQ-2503.5	LQ-4003.5
4.0	LQ-0004	LQ-1504	LQ-2504	LQ-4004
4.5	LQ-0004.5	LQ-1504.5	LQ-2504.5	LQ-4004.5
5.0	LQ-0005	LQ-1505	LQ-2505	LQ-4005
5.5	LQ-0005.5	LQ-1505.5	LQ-2505.5	LQ-4005.5
6.0	LQ-0006	LQ-1506	LQ-2506	LQ-4006
6.5	LQ-0006.5	LQ-1506.5	LQ-2506.5	LQ-4006.5
7.0	LQ-0007	LQ-1507	LQ-2507	LQ-4007
7.5	LQ-0007.5	LQ-1507.5	LQ-2507.5	LQ-4007.5
8.0	LQ-0008	LQ-1508	LQ-2508	LQ-4008
8.5	LQ-0008.5	LQ-1508.5	LQ-2508.5	LQ-4008.5
9.0	LQ-0009	LQ-1509	LQ-2509	LQ-4009
10	LQ-0010	LQ-1510	LQ-2510	LQ-4010

## HIGH PRESSURE, SCREW-IN

NOZ SIZE	0°	15°	25°	40°
2.0	LM-0002	LM-1502	LM-2502	LM-4002
2.5	LM-0002.5	LM-1502.5	LM-2502.5	LM-4002.5
3.0	LM-0003	LM-1503	LM-2503	LM-4003
3.5	LM-0003.5	LM-1503.5	LM-2503.5	LM-4003.5
4.0	LM-0004	LM-1504	LM-2504	LM-4004
4.5	LM-0004.5	LM-1504.5	LM-2504.5	LM-4004.5
5.0	LM-0005	LM-1505	LM-2505	LM-4005
5.5	LM-0005.5	LM-1505.5	LM-2505.5	LM-4005.5
6.0	LM-0006	LM-1506	LM-2506	LM-4006
6.5	LM-0006.5	LM-1506.5	LM-2506.5	LM-4006.5
7.0	LM-0007	LM-1507	LM-2507	LM-4007
7.5	LM-0007.5	LM-1507.5	LM-2507.5	LM-4007.5
8.0	LM-0008	LM-1508	LM-2508	LM-4008
8.5	LM-0008.5	LM-1508.5	LM-2508.5	LM-4008.5
9.0	LM-0009	LM-1509	LM-2509	LM-4009
10	LM-0010	LM-1510	LM-2510	LM-4010

### TECH LIBRARY - NOZZLES

Nozzles are the last part that the water touches on it's way out of the pressure washer. The spray nozzle is a small simple component that controls how much pressure and water flow is produced. The pump simply moves a certain amount of water. The restriction created at the nozzle is what causes the pressure to develop. If the spray nozzle hole size is so small that the pump can't force the water through it at the pumps rated pressure, then the water flowing from the nozzle is reduced. The unloader valve bypasses the extra water back to the pump. An oversized spray nozzle orifice will allow the flow of almost all the water from the pump at a reduced pressure. The way to obtain the most cleaning power from a machine is to closely match the spray nozzle orifice size to the flow and pressure ratings of the pump. Spray nozzles are manufactured with various fan spray patterns.

**Chemical Nozzles:** These nozzles are used with downstream chemical injection to provide chemical. They are available in either threaded or quick connect styles. The most common orifice sizes used for chemical nozzles are 30, 40, or 50. The large orifice size decreases the pressure created by the equipment. A wide fan pattern is usually desired with a chemical nozzle to provide quick and even surface coverage. The threaded nozzles can be used with a variety of nozzle holders or with a dual lance. This enables the equipment operator to switch from low-pressure chemical to high-pressure washing with clear water without having to return to the equipment. When using quick connect nozzles, switching the high-pressure nozzle with the chemical nozzle provides the same ability.

**Nozzle to Surface Distance:** The pressure created by the nozzle is created at the nozzle itself. As soon as the water stream starts to travel away from the nozzle the pressure drops rapidly. The force of the spray on a surface demonstrates this. Rarely is a nozzle held right up to the surface. Doing so can damage many surfaces. Generally a range of distance between four and ten inches seems to be the practical washing zone. A distance of over ten inches away from the surface generally is used for rinsing because at this distance the spray has very little impact. The most important factor governing how far from the surface the nozzle should be is the lack of damage to the surface combined with the cleaning result. On some wash jobs, a good example is house siding, you want to be a good cleaning distance, and at the same distance have the fan pattern hit on the top and the bottom of the clapboard. Depending on the distance required to obtain the desired cleaning result, the degree of fan can be changed so it impacts the area you desire.

**Nozzle Wear:** Spray nozzles wear out rapidly. The velocity of the water being propelled through the orifice as well as chemicals acting on the metal causes the orifice to wear larger. The orifice size is the biggest determining factor in the creation of pressure. As the orifice enlarges, the equipment pressure goes down. The use of a pressure gauge is valuable in determining how much pressure has been lost and when nozzle replacement is desirable. Nozzle wear or improper sizing is the most common factor that causes low-pressure problems. Do not attempt to compensate too much for nozzle wear by over adjusting the unloader valve. This increases the spike that occurs when the trigger gun is released. Consequently, it also increases hose failure, and wear on many equipment components.

**Quick Connect Nozzles:** These nozzles have a quick connect 1/4" plug incorporated as part of the nozzle. Most have a color-coding system that allows for easy fan spray identification. Red is zero, yellow is 15, green is 25, and white is 40. These nozzles must be connected into a quick connect coupler to use. When changing these nozzles it is very important to make sure the coupler locks down properly onto the nozzle plug. A habit of aiming the nozzle away from surfaces when first spraying is also a good idea. An improperly installed quick connect nozzle can be propelled out of the coupler and it can cause damage or injury.

**0° (Red) 15° (Yellow) 25° (Green) 40° (White)**

**Reading the Nozzle Size & Fan:** Nozzles are marked to indicate both orifice size and the degree of fan. Nozzles sometimes have the information stamped into the surface, and some nozzles have the information laser printed on the surface. Both methods of identification can wear off with use. Manufacturers add numbers and letters around the real information, but once you know how to pick out the real information it becomes easy to understand. First look for the degree of fan. After the degree of fan the orifice size will be listed. Orifice sizes less than ten will have a zero in front of them. Half sizes will have a decimal point with two numbers, like 6.5.

**Sizing Nozzles for Pressure:** The best way to adjust the pressure produced by a pressure washer is by increasing or decreasing the nozzle orifice size. It is important to know how to use a nozzle chart to accomplish this. On a standard nozzle chart, the top column that runs left to right is the pressure that you want to obtain. The left column top to bottom is the nozzle orifice size designation. The top to bottom column next to the orifice size column indicates the actual orifice measurement. The numbers in the shaded boxes all indicate gallons per minute of flow. The nozzle orifice size designation is obtained by the flow of water that goes through that hole size at 4000 PSI. So if you look at a nozzle chart the gallons per minute shown under the 4000 PSI column always is the same as the nozzle orifice size designation. When the water pressure is reduced below 4000 PSI, less water goes through the nozzle per minute. Pressures over 4000 PSI force more water through the nozzle each minute. Because of these facts, the nozzle chart becomes necessary. Using different nozzle orifice sizes to change pressure is better than adjusting the unloader valve. When the unloader valve is adjusted to lower the pressure the gallon per minute flow is also reduced. The flow is very important when working. Flow enables the operator to apply detergent, wash, and rinse at peak speed. Reducing the flow from four to three gallons per minute will increase cleaning time on average by 25%. Another words, a typical four hour job will now take five hours.

**Threaded Nozzles:** Industry standard for the thread size on spray nozzles is 1/4". They fit into the industry standard 1/4" trigger gun outlet port. They have NPT (national pipe thread). This type of thread gets tighter as it is threaded into another component. This is done to help seal the connection. Some accessories require 1/8" threaded nozzles, duct cleaners and some surface cleaners for example.

**Understanding Degree of Fan:** The most commonly used fan patterns are 0, 15, 25, 40, and 65 degrees. The higher the number of the fan, the wider the fan pattern is. A zero degree nozzle sprays in a pencil point pattern, which is a straight stream. This pattern yields the greatest surface impact. Unfortunately it isn't very practical for most wash applications because it covers such a small area. The practical answer when using a zero degree nozzle is the rotating nozzle. The characteristics of a fifteen-degree fan pattern are a tight fan pattern with excellent surface impact. The edges of the fan, because they end so sharply on the surface, sometimes make blending the cleaning result uniformly very difficult. A twenty-five degree of fan is the most popular. It is wider than fifteen-degree, making it easier to wash most common surfaces. The forty-degree of fan is also popular, it is a wider fan and the edges don't have as sharp an impact on the surface. This makes blending on the surface easier, which yields an even result on the wash surface. The down side of wider fan patterns is the spreading out of the surface impact. A sixty-five degree fan pattern is not popular for high pressure washing because the impact is too diffused for most work. This fan pattern is commonly acknowledged to be best for detergent application. The wide fan allows for rapid surface coverage.



## Stainless Steel & Brass Soap Nozzles

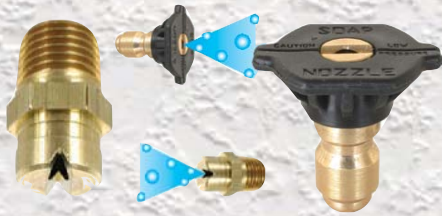

PART #	DESCRIPTION / PRICE	
1870	BRASS NOZZLE - Screw-In, 25°, 30	\$5.25
1871	BRASS NOZZLE - Screw-In, 25°, 40	\$5.25
1872	BRASS NOZZLE - Screw-In, 25°, 50	\$5.25
1873	BRASS NOZZLE - Screw-In, 40°, 30	\$5.25
1874	BRASS NOZZLE - Screw-In, 40°, 40	\$5.25
1875	BRASS NOZZLE - Screw-In, 40°, 50	\$5.25
1876	BRASS NOZZLE - Screw-In, 65°, 40	\$1.97
SSN-0030	STAINLESS NOZZLE - Screw-In, 0°, 30	\$6.95
SSN-0050	STAINLESS NOZZLE - Screw-In, 0°, 50	\$6.95
SSN-0060	STAINLESS NOZZLE - Screw-In, 0°, 60	\$6.95
SSN-0070	STAINLESS NOZZLE - Screw-In, 0°, 70	\$6.95
SSN-1515	STAINLESS NOZZLE - Screw-In, 15°, 15	\$6.95
SSN-1520	STAINLESS NOZZLE - Screw-In, 15°, 20	\$6.95
SSN-1525	STAINLESS NOZZLE - Screw-In, 15°, 25	\$6.95
SSN-1530	STAINLESS NOZZLE - Screw-In, 15°, 30	\$6.95
SSN-1535	STAINLESS NOZZLE - Screw-In, 15°, 35	\$6.95
SSN-1560	STAINLESS NOZZLE - Screw-In, 15°, 60	\$6.95
SSN-2515	STAINLESS NOZZLE - Screw-In, 25°, 15	\$6.95
SSN-2530	STAINLESS NOZZLE - Screw-In, 25°, 30	\$6.95
SSN-2540	STAINLESS NOZZLE - Screw-In, 25°, 40	\$6.95
SSN-2550	STAINLESS NOZZLE - Screw-In, 25°, 50	\$6.95
SSN-4015	STAINLESS NOZZLE - Screw-In, 40°, 15	\$6.95
1877	BRASS NOZZLE - Quick Connect, 65°, 40	\$ .74

## Nozzle Clean-Out Tool

Brass or Plastic

Quick Connect to Pressure Washer frame for safe keeping!



PART #	DESCRIPTION / PRICE	
1878	CLEAN-OUT TOOL BRASS	\$3.91
1879	CLEAN-OUT TOOL PLASTIC	\$1.97

## General Hi-Lo Nozzle

"Push" for Soap - "Pull" for Pressure



PSI: 4,100 PSI  
TEMP: 195° F

Hi-Lo settings allow for both cleaning and chem applications

PART #	DESCRIPTION / PRICE	
4002	2.0 NOZZLE SIZE ( Light Green)	\$14.53
4003	2.5 NOZZLE SIZE (Pink )	\$14.53
4004	3.0 NOZZLE SIZE ( White)	\$14.53
1292	3.5 NOZZLE SIZE (BROWN)	\$14.53
1293	4.0 NOZZLE SIZE (YELLOW)	\$14.53
1294	4.5 NOZZLE SIZE (BLUE)	\$14.53
1295	5.0 NOZZLE SIZE (PURPLE)	\$14.53
1296	5.5 NOZZLE SIZE (RED)	\$14.53
1297	6.0 NOZZLE SIZE (GREEN)	\$14.53
1299	7.0 NOZZLE SIZE (ORANGE)	\$14.53
1300	8.0 NOZZLE SIZE (GREY)	\$14.53

## Dirt Killer Hi-Lo Nozzle



PSI: 4,300 PSI  
TEMP: 195° F

"PUSH" for Soap  
"PULL" for Pressure

Hi-Lo settings allow for both cleaning and chem applications

PART #	DESCRIPTION / PRICE	
1686	VAIRO-JET - NOZZLE SIZE 4.0	\$34.95
1687	VARIO-JET - NOZZLE SIZE 4.5	\$34.95
1688	VARIO-JET - NOZZLE SIZE 5.5	\$34.95

## MTM DuraJet Nozzle

"Push" for Soap  
"Pull" for Pressure



PSI: 3,000 PSI  
TEMP: 300° F

Hi-Lo settings allow for both cleaning and chem applications

PART #	DESCRIPTION / PRICE	
1602	Push-Pull Nozzle 3.0 White Dot	\$7.97
1603	Push-Pull Nozzle 3.5 Yellow Dot	\$7.97
1604	Push-Pull Nozzle 4.5 Orange Dot	\$7.97
2050	Push-Pull Nozzle 5.0 Red Dot	\$7.97
2051	Push-Pull Nozzle 5.5 Blue Dot	\$7.97
2052	Push-Pull Nozzle 6.5 Black Dot	\$7.97
2053	Push-Pull Nozzle 7.5 Brown Dot	\$7.97
2054	Push-Pull Nozzle 8.0 Green Dot	\$7.97

## MTM DuraJet Nozzle

Variable Angle Only



PSI: 3,000 PSI  
TEMP: 300° F

Adjust From 0° thru 65°

PART #	DESCRIPTION / PRICE	
2055	Variable Nozzle 3.0 White Dot	\$6.49
2056	Variable Nozzle 3.5 Yellow Dot	\$6.49
2057	Variable Nozzle 4.5 Orange Dot	\$6.49
2058	Variable Nozzle 5.0 Red Dot	\$6.49
2059	Variable Nozzle 5.5 Blue Dot	\$6.49
2060	Variable Nozzle 6.5 Black Dot	\$6.49
2061	Variable Nozzle 7.5 Brown Dot	\$6.49
2062	Variable Nozzle 8.0 Green Dot	\$6.49



## Lance Caddy

Slip over the lance and attach lance to the trigger gun!



Holds 7 Nozzles  
Stainless Steel, only 0.53 lbs.

PART #	DESCRIPTION / PRICE
1266	LANCE CADDY \$7.24

## The Nozzle Keeper

- NEVER lose another nozzle!
- Install your favorite nozzles
- For 3 nozzle set-ups
- Nozzles sold separately



PART #	PRICE
1827	\$2.95

## Nozzle Holder Twist Type



One of our most popular holders

- 1 ea. 1/4" inlet & 2 ea. 1/4" nozzle outlets
- HP nozzle on one side - LP on the other side
- Twist to change nozzle & draw chem

PART #	DESCRIPTION / PRICE
1275	NOZZLE HOLDER, TWIST TYPE \$19.96
1276	2 EA TEFLON SEATS FOR #1275 \$ .99

## Allison Dual Nozzle Holder - Ball Type

Now Available with Corrosion Proof Ceramic Ball

**NOT MADE IN CHINA!**

This is the best in the industry!

- GPM: 12 • PSI: 3,500
- Up to 190 degrees
- 1/4" inlet from lance
- 2 ea. 1/4" outlets accommodates 2 nozzles
- Rotate lance to change to soap nozzle

PART #	DESCRIPTION / PRICE
1267	Holder with Stainless Steel Ball \$14.84
1269	Holder with Ceramic Ball \$16.93
1745	Replacement Ceramic Bal, 13/32 \$ 2.95



Shown here with optional swivel.

## Nozzle Boot

Eliminates Scratched Finishes



- Install boot on lance and nozzle in boot
- The rubber bumper protects surfaces from being scratched by the nozzle

PART #	PRICE
1271	NOZZLE BOOT \$1.96

## Nozzle Holder - Shower Type

GPM: 8  
PSI: 3,650 PSI



1/4" inlet from lance  
1/4" outlet - accommodates one nozzle.  
Twist to reduce pressure to draw chemical.

PART #	PRICE
1274	\$9.63



Bolts to any machine

- No more misplaced nozzles!
- Comes complete with grommets & bolts

## Nozzle Caddy for Machine

PART #	DESCRIPTION / PRICE
1621	COMPLETE HOLDER \$6.98
1622	REPLACEMENT GROMMET \$ .32

## Belt Clip Nozzle Holder



This high density rubber boot holds 4 nozzles securely.

- No more misplaced nozzles!
- Attaches to belt loop

PART #	PRICE
7780	\$4.89



## Trombone Dual Nozzle Holder

High Pressure Nozzle goes in the top.

Low Pressure Nozzle goes in the bottom.

When you want low pressure soap simply release the trigger & reach up and pull back on the piston.

Rated to 11 GPM @ 4,000 PSI



PART #	PRICE
7775	\$9.63



# ROTOJET TURBO NOZZLE

#1 Seller in 2003 thru 2008

0° - 25° Nozzle Rotation  
Up to 3,000 RPM  
High Strength Forged Brass



190° Max Temp  
(Shown with optional filter)

Precision ceramic orifice and race  
Always start a turbo with nozzle pointed down

Wider pattern for cleaning larger areas such as graffiti removal, concrete floors and side walks, etc.

PART #	PRICE	PSI	Noz Size	Kit #	PRICE
1548	\$41.06	3600	3.5	1570	\$28.88
1549	\$41.06	3600	4.0	1571	\$28.88
1550	\$41.06	3600	4.5	1572	\$28.88
1551	\$41.06	3600	5.0	1573	\$28.88
1552	\$41.06	3600	5.5	1574	\$28.88
1553	\$41.06	3600	6.0	1575	\$28.88
1562	\$54.58	4500	4.0	1584	\$36.42
1563	\$54.58	4500	4.5	1585	\$36.42
1564	\$54.58	4500	5.0	1586	\$36.42
1565	\$54.58	4500	5.5	1587	\$36.42
1566	\$54.58	4500	6.0	1588	\$36.42
1567	\$54.58	4500	7.0	1589	\$36.42
1554	\$79.95	5800	4.0	1576	\$39.96
1555	\$79.95	5800	4.5	1577	\$39.96
1556	\$79.95	5800	5.0	1578	\$39.96
1557	\$79.95	5800	5.5	1579	\$39.96
1558	\$79.95	5800	6.0	1580	\$39.96
1559	\$79.95	5800	7.0	1581	\$39.96
1560	\$79.95	5800	8.0	1582	\$39.96
1561	\$79.95	5800	12.0	1583	\$39.96

## TURBO SHIELD

The 'Splatter Shield' attaches to any lance and covers the Turbo Nozzle so harsh chemicals and pressure do not come in contact with delicate surfaces.

For All Turbos  
Quickly attaches to lance



PART	PRICE
1497	\$41.36

# ROTOMAX

0° - 15° Nozzle Rotation  
Up to 3,000 RPM  
176° Max Temp



Tighter pattern for cleaning concentrated pollutant such as 'chewing gum'

PART #	PRICE	PSI	GPM	Kit #	PRICE
1498	\$39.96	3500	2.1-2.6	1501	\$19.98
1499	\$39.96	3500	2.9-4.0	SAME	\$19.98
1500	\$39.96	3500	4.2-6.0	SAME	\$19.98

# SUPER ROTOMAX

0° - 15° Nozzle Rotation  
Up to 3,000 RPM  
176° Max Temp



Tighter pattern for cleaning concentrated pollutant such as 'chewing gum'

PART #	PRICE	PSI	GPM	Kit #	PRICE
1502	\$109.87	5800	2.0-4.0	1504	\$45.36
1503	\$109.87	5800	4.1-7.0	Same	\$45.36

# M-16 Thruster Nozzle



Attaches to end of Lance



Reaches 3-4 stories from the safety of the ground!  
Want to go even higher than 3 stories?  
Simply connect the thruster to a Telescoping Lance!  
Then throw up to 6 stories high!

- Push for Fully Adjustable Soap from 0° to 65°
- Pull Back for Adjustable High Pressure from 0° to 65°

Comes Standard with:

- 50' of Chemical Line
- Premium Stainless/Brass Filter

PART #	DESCRIPTION	PRICE
1992	THRUSTER WITH 3.5 NOZZLE	\$39.87
1993	THRUSTER WITH 4.0 NOZZLE	\$39.87
1994	THRUSTER WITH 4.5 NOZZLE	\$39.87
1995	THRUSTER WITH 5.0 NOZZLE	\$39.87
1996	THRUSTER WITH 5.5 NOZZLE	\$39.87
1997	THRUSTER WITH 6.0 NOZZLE	\$39.87
1998	THRUSTER WITH 6.5 NOZZLE	\$39.87
1999	THRUSTER WITH 7.0 NOZZLE	\$39.87
2000	THRUSTER WITH 8.0 NOZZLE	\$39.87
1439	REPAIR KIT FOR INJECTOR BODY	\$ 9.89

# VIPER TURBO

0° - 15° Nozzle Rotation  
Up to 3,000 RPM  
190° Max Temp



Tighter pattern for cleaning concentrated pollutant such as 'chewing gum'

PART #	PRICE	PSI	Noz	Kit #	PRICE
1505	\$49.67	5000	4.5	1506	\$29.65
1507	\$49.67	5000	5.5	1508	\$29.65

# DIRT KILLER TURBOS



3200 PSI	PRICE	SIZE	KIT	PRICE
1471	\$55.03	3.0	1476	\$39.60
1472	\$55.03	3.5	1477	\$39.60
1473	\$55.03	4.5	1478	\$39.60
1474	\$55.03	5.5	1479	\$39.60
1475	\$55.03	7.0	1480	\$39.60
4700 PSI	PRICE	SIZE	KIT	PRICE
1481	\$94.88	3.5	1489	\$54.02
1482	\$94.88	4.0	1490	\$54.02
1483	\$94.88	4.5	1491	\$54.02
1484	\$94.88	5.5	1492	\$54.02
1485	\$94.88	6.0	1493	\$54.02
1486	\$94.88	7.0	1494	\$54.02
1487	\$94.88	8.0	1495	\$54.02
4400	\$55.00	9.0	N/A	---
1488	\$94.88	10.0	1496	\$54.02



**THE INDUSTRY'S BEST 'FULL-PATTERN' TURBO!**

**4000 PSI**

**M-T-M HYDROJETS**

**5000 PSI**

TURBO	NOZ	KIT
\$34.70		\$21.48
16221	2.5	41374
16222	3.0	41375
16223	3.5	41376
16224	4.0	41377
16225	4.5	41378
16226	5.0	41379
16227	5.5	41380
16228	6.0	41381



TURBO	NOZ	KIT
\$49.40		\$29.23
16284	3.0	41482
16285	3.5	41483
16286	4.0	41484
16287	4.5	41485
16288	5.0	41486
16289	5.5	41487
16290	6.0	41488
16291	6.5	41489
16292	7.0	41490
16293	7.5	41491

**PA TURBO NOZZLE**



Features spring loaded shock absorption for longer ceramic life.

"Quiet-Run" technology with an 18° pattern

WHEN YOU COMPARE THE PARTS LIST OF THE BLUE COVER TURBO TO THE RED COVER TURBO you will find that every part is identical but the cover itself. So why would one spend the extra money?

PART #	PRICE	Permissible PSI	Noz Size	Kit #	PRICE
2002	\$45.54	5100	3.0	2003	\$28.44
2004	\$45.54	5100	3.5	2005	\$28.44
2006	\$45.54	5100	4.0	2007	\$28.44
2008	\$45.54	5100	4.5	2009	\$28.44
2010	\$45.54	5100	5.0	2011	\$28.44
2012	\$45.54	5100	5.5	2013	\$28.44
2014	\$45.54	5100	6.0	2015	\$28.44
2016	\$45.54	5100	6.5	2017	\$28.44
2018	\$45.54	5100	7.0	2019	\$28.44
2020	\$45.54	5100	8.0	2021	\$28.44

**High Pressure Filter for Turbos**

Manufacturers will not warranty Turbos if they have been used without a filter



#1510 Shown

PART #	PSI	Configuration	PRICE
1509	5000	1/4" MPT x 1/4" FPT	\$5.88
1510	5000	1/4" Plug x 1/4" MPT	\$6.24

**ALLISON STILETTO TURBO LASER**

...cuts like a RAZOR KNIFE at a much higher RPM

**THE SHARPEST CUTTING TURBO IN THE INDUSTRY!**



With or Without Filter

**THE INDUSTRY'S BEST 'TIGHT-PATTERN' TURBO!**

Place the Stiletto Turbo Laser on the end of the lance - pull the trigger and watch the zero degree laser produce a cleaning path of 10 to 60 degrees\* while rotating as high as 3,500 rpm.

Absolutely nothing in the industry cleans like the...

**STILETTO TURBO LASER!**

**OPERATING PRESSURE 5100 PSI**

At 2,000 to 3,000 psi - you'll lift chewing gum from sidewalks, barnacles from boats, remove graffiti & paint, remove concrete from truck bodies and new construction, rust from trailer frames, etc.

At 5,000 (+) psi - you can remove paint from auto bodies and chew through plywood and concrete. Yes - there is always a reason to own a...

**STILETTO TURBO LASER!**

PART #	PRICE	PART #	PRICE	Noz Size	Kit #	PRICE
No Filter		w/Filter				
1965	\$51.17	1965F	\$57.82	3.0	1966	\$28.44
1967	\$51.17	1967F	\$57.82	3.5	1968	\$28.44
1969	\$51.17	1969F	\$57.82	4.0	1970	\$28.44
1971	\$51.17	1971F	\$57.82	4.5	1972	\$28.44
1973	\$51.17	1973F	\$57.82	5.0	1974	\$28.44
1975	\$51.17	1975F	\$57.82	5.5	1976	\$28.44
1977	\$51.17	1977F	\$57.82	6.0	1978	\$28.44
1979	\$51.17	1979F	\$57.82	6.5	1980	\$28.44
1981	\$51.17	1981F	\$57.82	7.5	1982	\$28.44
1983	\$51.17	1983F	\$57.82	8.0	1984	\$28.44

Tighter pattern for cleaning concentrated pollutant such as chewing gun, paint removal, tar, bugs, etc.





## TINGLEY PREMIUM BOOTS

These boots are so comfortable you can work long days without discomfort. They keep your feet warm and dry. Steel toes protect your toes from unfortunate drops and crushing. They are chemical resistant, have an aggressive tread to keep you on your feet, and they have removable insoles so things stay pleasant inside, day after day. They are stylish and ready for anything. Once you work in these you will never go back.



**\$38.62**

- #7290 Size 9
- #7210 Size 10
- #7211 Size 11
- #7212 Size 12

## TINGLEY ECONOMY BOOTS

The time tested Tingley boots have served mobile washers well for decades. Tingley's economy boot provides a good waterproof boot at a very reasonable price. It is available with a plain toe or a steel toe. They keep your feet warm and dry. They are resistant to fats and caustics. They have removable insoles so things stay pleasant inside, day after day.

**PLAIN TOE  
\$18.77**

- #7090 Size 9
- #7010 Size 10
- #7011 Size 11
- #7012 Size 12

**STEEL TOE  
\$24.38**

- #8090 Size 9
- #8010 Size 10
- #8011 Size 11
- #8012 Size 12



## TINGLEY GREEN CHEMICAL RESISTANT

The time tested Tingley rain gear have served mobile washers well for decades. This gear will not fail you when you need it most. The rain gear is light weight, comfortable and warm. It keeps you dry and stays flexible in all temperatures. When it's cold, wear a few layers underneath and you can go all day.

**JACKET  
GREEN CHEMICAL RESISTANT  
\$46.37**

- #7280M Medium
- #7280L Large
- #7280XL X-Large
- #7280XXL XX-Large

**OVERALL  
GREEN CHEMICAL RESISTANT  
\$38.63**

- #7281M Medium
- #7281L Large
- #7281XL X-Large
- #7281XXL XX-Large

## TINGLEY CLASSIC YELLOW RAIN GEAR

This is quality raingear at an attractive price. Quality & value is what this gear is all about. It holds up to the harshest conditions.

**JACKET - YELLOW  
\$42.82**

- #7282M Medium
- #7282L Large
- #7282XL X-Large
- #7282XXL XX-Large



**OVERALL - YELLOW  
\$36.54**

- #7283M Medium
- #7283L Large
- #7283XL X-Large
- #7283XXL XX-Large

## SAFETY REFLECTIVE RAIN GEAR

When you are working in areas where traffic is a concern, the reflective rain gear could very well be a life saver. The rain gear is comfortable and warm. They stay flexible in all temperatures. They are chemical resistant. Did I mention it keeps you clean underneath too? Strip it off, wash your hands, and you are ready for a night on the town. Buy a jacket and overalls for complete and matching protection. Complete your protective package with genuine Tingley waterproof boots.



**OVERALLS  
\$32.74**

- #7285M Medium
- #7285L Large
- #7285XL X-Large
- #7285XXL XX-Large



**JACKET  
\$57.45**

- #7284M Medium
- #7284L Large
- #7284XL X-Large
- #7284XXL XX-Large



**PANTS  
\$36.77**

- #P23122M Medium
- #P23122L Large
- #P23122XL X-Large
- #P23122XXL XX-Large



# OUTDOOR GEAR



# Tingley



- S75522 • Lime**
- Long Sleeve
  - Birds Eye Polyester
  - 2" Silver Reflective Tape
  - 1 Pocket
  - Sizes S-5X

## SHIRTS

Part #	Price
S75522	N/A
S75029	N/A
S75022-S	\$17.26
S75022-M	\$17.26
S75022-L	\$17.26
S75022-XL	\$17.26
S75022-XXL	\$17.26
S75022-XXXL	\$17.26
S78029	N/A
S78022-S	\$46.55
S78022-M	\$46.55
S78022-L	\$46.55
S78022-XL	\$46.55
S78022-XXL	\$48.55
S78022-XXXL	\$48.55

- S75029 • Orange / S75022 • Lime**
- Short Sleeve
  - Birds Eye Polyester
  - 2" Silver Reflective Tape
  - 1 Pocket
  - Sizes S-5X

Birds Eye Polyester - Moisture Management Fabric Wicks Perspiration Away from the Body to Keep You Cooler and More Comfortable.

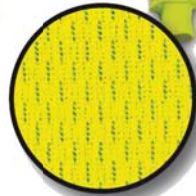

## Class 3 Sweatshirts



- S78029 • Orange**  
**S78022 • Lime**
- Crew Neck
  - Polyester
  - 2" Silver Reflective Tape
  - 1 Pouch Pocket
  - Sizes S-5X



- S78122 • Lime**  
**S78129 • Orange**
- Hooded
  - Polyester
  - 2" Silver Reflective Tape
  - Zipper Closure
  - 2 Pockets
  - Sizes S-5X



Size Small Sweatshirts Have Fluorescent Color Pockets to Meet ANSI 107 Requirements.





# SAFETY VEST



## VEST

Part #	Price
V71622-SM	\$14.79
V71622-LXL	\$14.79
V71622-2X3X	\$14.79

- V71622 • Lime**
- Polyester Solid
  - 2" Silver Reflective Tape
  - Hook & Loop Closure
  - 2 Interior Pockets
  - Sizes S/M, L/XL, 2X/3X, 4X/5X



## VEST

Part #	Price
V70722-SM	\$14.79
V70722-LXL	\$14.79
V70722-2X3X	\$14.79

- V70722 • Lime**
- Polyester Mesh
  - 2" Silver Reflective Tape
  - Hook & Loop Closure
  - 2 Interior Pockets
  - Sizes S/M, L/XL, 2X/3X, 4X/5X



## Protective Apron

A41008 \$19.87



## Protective Sleeves

S41108 \$9.97

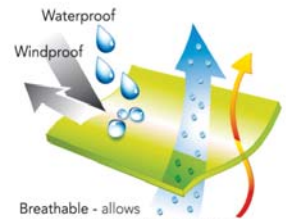

Breathable - allows moisture vapor and heat to escape

Breathable to ASTM E96

## ICON 3.1

Part #	Price
J24172-S	\$99.17
J24172-M	\$99.17
J24172-L	\$99.17
J24172-XL	\$99.17
J24172-XXL	\$99.17

SIZING								
<b>CLASS 2 &amp; 3 SAFETY VESTS</b>								
Sizes	S-M	L-XL	2X-3X	4X-5X				
Chest Size	36-42	44-50	52-58	60-66				
<b>CLASS 2 &amp; 3 T-SHIRTS AND SWEATSHIRTS</b>								
Sizes	S	M	L	XL	2X	3X	4X	5X
Chest Size	36-38	40-42	44-46	48-50	52-54	56-58	60-62	64-66
<b>CLASS E MESH PANTS</b>								
Sizes	S-M	L-XL	2X-3X	4X-5X				
Waist	40-46	48-54	56-62	64-70				
Inseam	30 1/4	31 1/2	32 3/4	34				
<b>CLASS 3 JACKETS</b>								
Sizes	S	M	L	XL	2X	3X	4X	5X
Chest Size	36-38	40-42	44-46	48-50	52-54	56-58	60-62	64-66
Jacket Length	29	30	31	31	32	32	32	33
Sleeve Length	33	34	34 1/2	35	35 1/2	36	36	38
<b>CLASS E OVERALLS AND PANTS</b>								
Sizes	S	M	L	XL	2X	3X	4X	5X
Waist	32-34	36-38	40-42	44-46	48-50	52-54	56-58	60-62
Inseam	28	29	30	31	32	32	32	33
<b>CLASS 3 COATS</b>								
Sizes	S	M	L	XL	2X	3X	4X	5X
Chest Size	36-38	40-42	44-46	48-50	52-54	56-58	60-62	64-66
Coat Length	47	48	50	50	52	52	52	52
Sleeve Length	33	34	34 1/2	35	35 1/2	36	36	38

# JACKETS



# ICON 3.1™

Premium Insulated All Season Outerwear

**Jacket J24172 • Lime**  
 Class 3 • All the Premium Features of the Icon™ plus a Removable 300 Gram Insulating Fleece Liner with 2 Slash Pockets, Zippers and Adjustable Elastic Drawcord • Sizes S-5X





CHANCE

they came...  
and touched our lives  
and we were happy  
and they were happy.

We want to share with  
you some pictures of a few  
of our special friends who  
gave us an opportunity to share  
some special moments in their lives before  
they passed on to a greater life.

There are many who at, first glance, might  
say... 'he's just a dog' but trust me when I  
tell you that given the chance they will fill  
your heart with something that you have  
never experienced before.

I hope you enjoy seeing some of the  
animals that you have  
helped us to provide a  
better life. And I hope  
you remember that  
there is not a day that  
goes by that we don't  
think about how  
fortunate we are to  
have such great  
customers who help  
us do the little things  
we do to make a  
child's life or an  
animal's life a little better.



RUFUS



HOBO



SPIRIT



JOSIE



## BECKETT BURNERS



- Interchanges with Wayne
- Easy installation
- Special burner made to our specifications

**One of the longest lasting, most trouble free burners in the Industry!**

PART #	DESCRIPTION / PRICE
1390	12Volt ADC - for Washers up to 6 GPM \$423.91
1391	12 Volt SDC - for Washers over 6 GPM \$499.70
1393	115 Volt AFG -for Washers up to 6 GPM \$381.55
1394	115 Volt SF - for Washers over 6 GPM \$397.97

## Burner Nozzles



PART #	DESCRIPTION / PRICE
1379	BURNER NOZZLE, 1.00 80B \$5.68
1380	BURNER NOZZLE, 1.25 80B \$5.68
1381	BURNER NOZZLE, 1.50 80B \$5.68
1382	BURNER NOZZLE, 1.75 80B \$5.68
1383	BURNER NOZZLE, 2.00 80B \$5.68
1384	BURNER NOZZLE, 2.25 80B \$5.68
1385	BURNER NOZZLE, 2.50 80B \$5.68
1386	BURNER NOZZLE, 2.75 80B \$5.68
1387	BURNER NOZZLE, 3.00 80B \$5.68

## "On/Off" Burner Switch

- On / Off positioning
- Rated to 50 Amps @ 12 Volts



PART #	DESCRIPTION / PRICE
1388	ON/OFF SWITCH \$6.89

## Adjustable Thermostats

- Panel Mount
- Adjustable
- Rated to 3,500 PSI
- Super quick response



PART #	DESCRIPTION	PRICE
1422	PREMIUM THERMOSTAT 302 DEGREES	\$28.45
1425	PREMIUM THERMOSTAT 194 DEGREES	\$28.45

## Pre-Set Thermostats

**Last Longer and More Accurate** than typical thermostats

- On and Off at constant temperature
- 5° - 8° deadband - super quick response



PART #	DESCRIPTION / PRICE
1884	PRE-SET THERMOSTAT, SHUTS OFF AT 160° \$19.12

## Adjustable Thermostats

- Mounts on discharge side of heating coil
- Interchanges with all in-line thermostats
- Temp range 60°F to 230°F



PART #	DESCRIPTION / PRICE
1426	IN LINE THERMOSTAT \$58.25

## Hi-Limit Safety Burner Shut Down

- Shuts down the fuel solenoid at 210°



PART #	DESCRIPTION / PRICE
1107	HI LIMIT SWITCH WITH LEAD \$20.87

## Pressure Switch

PREMIUM SERIES FOR PROFESSIONAL EQUIPMENT

- Rated to 250V, 15 amps & 190°F



PART #	DESCRIPTION	PRICE
1370	PRESSURE SWITCH, 3,650 PSI, 1/4" MPT	\$21.16
1371	PRESSURE SWITCH, 3,650 PSI, 3/8" MPT	\$21.16
1372	PRESSURE SWITCH, 6,500 PSI, 1/4" MPT	\$55.96

## Flow Switch

- Tungsten contact reed switch
- Viton seals
- Rated to 4,400 PSI
- For solenoid control only



PART #	DESCRIPTION / PRICE
1367	VERTICAL MOUNT ONLY \$34.90
1368	VERTICAL OR HORIZONTAL \$34.90

## Industrial Flow Switch



- Both are rated to 5,000

PART #	DESCRIPTION / PRICE
1369	FLOW SWITCH, TMT, 12 GPM \$39.84
2272	PHOENIX, RATED TO 18 GPM \$121.85

## Vac Switch

- Installs on the inlet side of the pump
- 1/4" FPT connector
- Heavy duty 16 Amp contact
- 140°F maximum water temperature



PART #	DESCRIPTION / PRICE
1373	VACUUM SWITCH, FOR GAS ENGINES \$19.94
1374	VACUUM SWITCH, FOR ELECTRIC MOTORS \$19.94



## Transformers & Igniters

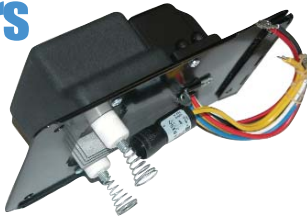

PART #	DESCRIPTION / PRICE
1404	12V IGNITOR ASSY SDC BECKETT \$ 84.14
1404C	12V IGNITOR ASSY SDC BECKETT w/CAD CELL \$107.49
1405	12V IGNITOR ASSY ADC BECKETT \$ 84.14
1405C	12V IGNITOR ASSY ADC BECKETT w/CAD CELL \$107.49
1406	TRANSFORMER FOR 120V 'A' BECKETT Old Style \$ 58.43
1407	TRANSFORMER FOR 230V 'A' SERIES BECKETT \$ 64.32
1408	TRANSFORMER FOR 230V 'S' SERIES BECKETT \$ 66.12
1409	TRANSFORMER FOR 120V 'A' BECKETT SMALL VERSION - See 1406 for old style \$ 48.48
1375	IGNITER, WAYNE, 12V, BACK HINGE FOR MSR \$109.15
1376	TRANSFORMER, WAYNE, 120V SIDE HINGE \$ 65.68
1377	TRANSFORMER, WAYNE, 120V, BACK HINGE \$ 76.56
1378	TRANSFORMER, WAYNE, 230V, SIDE HINGE \$ 73.57

## Fuel Solenoid



Fits Beckett and Suntec

PART #	DESCRIPTION / PRICE
1418	SUNTEC 120 VOLT \$24.87
1392	SUNTEC 220 VOLT \$24.87
1417	SUNTEC 12 VOLT \$25.92

## FUEL PUMPS

- Fits Beckett & Wayne
- SunTech you must order solenoid separately
- Becketts come with solenoid



PART #	DESCRIPTION
1399	FUEL PUMP, A2VA7116 \$44.11
1400	FUEL PUMP, A1VA7112 \$54.85
1402	FUEL PUMP, A1YA7912 \$63.12
1397	BECKETT WITH 115 VOLT SOLENOID \$53.59
1398	BECKETT WITH 12 VOLT SOLENOID \$56.15
1396	KIT FOR BECKETT SOLENOID, 12 VOLT \$12.66
1395	KIT FOR BECKETT 115V SOLENOID \$10.83

## Burner Motors

These motors fit both Beckett and Wayne Burners



PART #	DESCRIPTION
1410	3450 RPM, 1/7 HP, 115V (2456U) \$ 59.49
1411	3450 RPM, 1/5 HP, 115V (2900U) \$ 72.66
1412	3450 RPM, 1/6 HP, 13.5V (21699U) \$ 71.35
1413	3450 RPM, 1/4 HP, 12V (21539) \$124.06
1414	3450 RPM, 1/4 HP, 115/240V (21344) \$ 97.55
1415	3450 RPM, 1/4 HP, 240V (2899) \$ 77.36

## Beckett & Wayne Burner Parts

PART #	DESCRIPTION / PRICE
1350	Universal Burner to Coil Gasket \$ 2.34
1217	Blower Wheel, Beckett SF - SM \$14.49
	5-3/4D x 3-7/16W
	Blower Wheel, Beckett AFG \$11.48
1312	4-1/4 x 2-7/16
1197	Blower Wheel, Beckett ADC \$14.66
	5-3/4D x 3-7/16W
1261	Blower Wheel, Beckett SR \$16.26
	6-1/4D x 3-7/16W
1199	Blower Wheel, Beckett SDC \$16.26
	5-3/4D x 3-7/16W
1170	Blower Wheel, Wayne \$ 6.88
	5-3/16 x 3-7/16
1201	Blower Wheel, Wayne \$19.02
	6-1/4 x 4-3/16
1171	Blower Wheel, Wayne \$ 5.76
	4-1/4 x 3-1/8
1277	Blower Wheel to Pump Coupling \$ 4.76
	Beckett SM - SF
1278	Blower Wheel to Pump Coupling \$ 3.88
	Beckett AFG
1198	Blower Wheel to Pump Coupling \$ 3.91
	Beckett ADC
1200	Blower Wheel to Pump Coupling \$ 4.07
	Beckett SDC

## Burner Tune-Up Kits



- Beckett kit is electrodes and set gauge only
- Wayne kit includes electrodes, coupling, gauge & fuel line

PART #	DESCRIPTION / PRICE
1416	TUNE UP KIT BECKETT \$ 7.94
1389	WAYNE TUNE-UP KIT \$29.29

## Racor Fuel Filter Water Separator



PART #	DESCRIPTION / PRICE
1419	Complete Unit/Filter \$38.96
1420	Replacement Filter \$19.86

## M-T-M Fuel/Water Separator

- Water settles to the bottom of the bowl instead of passing to the burner
- When water is visible simply "twist" open the bottom 'dump' valve
- Water is much more visible in this filter than it is with the RACOR & is less expensive!



PART #	DESCRIPTION
1794	FUEL/WATER SEPARATOR, REPLACES RACOR \$29.96
1793	FILTER ELEMENT \$13.93





## SET-UP YOUR OWN 12 VOLT BURNER DIAGNOSTIC CENTER

It will tell you in 2 seconds what it would normally take 2 hours to figure out on your own. A very simple wiring job using the enclosed instructions will have you up and running with a complete 12 volt burner diagnostic center on your machine in 'no time flat.'

It takes them  
**2 HOURS**

to figure out why their  
burner is not working.

It will take you  
**2 SECONDS!**

PART #	PRICE
4001	\$119.74

If your burner stops...  
just look at the lights.

The one that is  
**NOT LIT**  
is the problem.

Change that part and  
you are back up running.

### 12 Volt Burner Relay

Most 12 Volt Burner failures come as a result of the tremendous spiking that occurs when the burner cycles between on and off.

This relay comes with easy to install instructions. It acts as a "shock absorber" as this erratic electricity passes from the battery to the burner.

The installation of either of these relays virtually eliminates 12V burner problems.



### WINCO GENERATOR

- 2,000 watt, 120 volt, 3,600 RPM
- Rotates in either direction
- 3 carbon brushes
- Dual sealed permanent bearing
- Units require approx. 4-5 horsepower



PART #	DESCRIPTION / PRICE	
1434	2,000 WATTS WINCO GENERATOR	\$459.86
1435	BRUSH (3 REQUIRED) FOR 2000 WATT #1434	\$ 10.78
1436	RECEPTACLE (2 REQUIRED) FOR 2000 WATT #1434	\$ 9.32
1437	RECTIFIER (1 REQUIRED) FOR 2000 WATT #1434	\$ 37.66

On this page we pay the freight on \$50.00 Web Orders or \$200.00 Call-in Orders



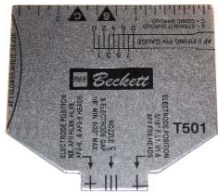

## Beckett Nozzle Gauge

This gauge is used to set the proper electrode gap on Beckett Burners.

- Remove Burner from Coil Assembly
- Butt the gauge up against the Burner Nozzle and set electrodes

PART #	PRICE
4501	\$2.49

## CHEK-MATE Transformer/Igniter Tester



- No more guessing!
- Simply touch the two electrodes and if the light comes on the unit is working properly.

PART #	PRICE
1947	\$54.36

## Resteable Fuses & Diagnostic Center Lights



- Use 10 AMPs for flow, pressure, vac, hi-limit switches & thermostats
- Use 30 AMP for Burner Motors, On/Off

PART #	ALL CIRCUIT BREAKERS	\$5.36
1741	10 AMP Circuit Breaker	
1742	15 AMP Circuit Breaker	
1743	30 AMP Circuit Breaker	



PART #	ALL REPLACEMENT LIGHTS	\$14.67
5796	Flow Switch Light - Blue - 12V	
5797	Thermostat Light - Red - 12V	
5798	Hi-Limit Light - Yellow - 12V	
5790	Flow Switch Light - Blue - 115V	
5791	Thermostat Light - Red - 115V	
5792	Hi-Limit Light - Yellow - 115V	

## NEED A COIL or Coil Replacement Parts

We can match-up any coil you are trying to replace.

- We build them better than original equipment
- Custom Coil Available for those exotic projects we can all come up with.

## REPLACEMENT DISC FOR COIL END CAPS



PART #	DESCRIPTION	PRICE
1038	18" Donut with hole / Burner End	\$36.36
1039	18" Solid Disc / Exhaust End	\$24.51



## COIL INSULATION BLANKET

- Coil wraps need special insulation
- This is enough to do one coil
- You should always keep a spare wrap on hand because it is doubtful that you will find it locally in case of an emergency

PART #	PRICE
1037	\$29.63

## Burner Fuel Pump Pressure Gauge



- Fuel pumps run between 100 & 150 PSI
- Comes ready to mount with a 2 1/2" x 1/8" pipe

PART #	DESCRIPTION / PRICE
1128	200 PSI GAUGE/TESTER \$5.91

## BURNER/COIL SOOT REMOVER



Cleans burner tips, improves burner efficiency, delivers more heat from less fuel and combats the formation of sludge and gum deposits in the fuel tank, line and filter.

**NOTE:**  
This product can not ship 'AIR'

PART #	DESCRIPTION / PRICE
6998	1 PINT \$ 9.93
6999	1 QUART \$17.12

## Fuel Filter Mounting Block



For All Fuel Filters

- 1/4" FPT inlet and outlet
- Bolts directly to the frame or remotely
- Takes the load off the burner fuel pump

PART #	PRICE
1115	\$7.16

## Coil Blow Out Valve



- Install on inlet side of pump
- Use air pressure to blow water out of the system to prevent freezing.

PART #	PRICE
1074	\$4.88





We Carry the Complete Line of:  
**KUBOTA, KOHLER & LOMBARDINI**  
**DIESEL ENGINES**

**ALL DIESELS COME WITH  
 SHAFT, RADIATOR, FAN & CONTROLS**

 = TECHNICAL DATA ON WEB





 **KD350** \$1548.80  
 1 Cylinder » 349 cc  
 » 5.0 kW/6.7 HP  
 » 3600 RPM  
 » 12.2 ft. lbs @ 2400 RPM

 **KD420** \$1798.80  
 1 Cylinder » 442 cc  
 » 7.3 kW/9.8 hp  
 » 3600 rpm  
 » 17 ft lbs @ 2200 rpm

 **KD477** \$3338.07  
 2 Cylinders » 954 cc  
 » 16.2 kW/21.7 HP  
 » 3600 RPM  
 » 40.6 ft. lbs. @ 2200 RPM





 **KD625-2** \$3515.72  
 2 Cylinders » 1248 cc  
 » 18.8 kW/25.2 HP  
 » 3000 RPM  
 » 55.3 ft. lbs. @ 2000 RPM

 **KDW702** \$3429.92  
 2 Cylinders » 686 cc  
 » 12.5 kW/16.8 HP  
 » 3600 RPM  
 » 29.9 ft. lbs @ 2000 RPM

 **KDW1003** \$3644.72  
 3 Cylinders » 1028 cc  
 » 19.5 kW/26.1 HP  
 » 3600 RPM  
 » 47.2 ft. lbs. @ 2000 RPM



 **KDW1404** \$4494.66  
 4 Cylinders » 1372 cc  
 » 26 kW/34.9 HP  
 » 3600 RPM  
 » 62 ft. lbs. @ 2000 RPM

 **KDW1603** \$4704.94  
 3 Cylinders » 1649 cc  
 » 30.0 kW/40.8 HP  
 » 3000 RPM  
 » 83.3 ft. lbs. @ 1600 RPM

 **KDW2204** \$5545.92  
 4 Cylinders » 2199 cc  
 » 38 kW/51 HP  
 » 3000 RPM  
 » 106.2 ft. lbs. @ 2000 RPM



We Carry the Complete Line of:  
**KOHLER & KUBOTA**  
**GAS ENGINES**



**14 HP**

**New from...  
 KOHLER.**



**GAS ENGINES**

CS7T	Kohler, 7 HP, 3/4" Shaft, w/Muf.	\$295.60
1772	Kohler, 8.5 HP, 1" Shaft, w/Muf.	\$591.87
2068	Honda, 13 HP, 1" Shaft, w/Muf.	\$522.30
KO14	Kohler, 14 HP, 1" Shaft, w/Muf.	\$463.59
KO14E	Kohler, E/Start, 14 HP, 1" Shaft, w/Muf.	\$643.12
1829	Kohler, 18 HP, 20 Amp Recharge, 1" - w/OFS Muf.	\$882.80
1732	Vanguard, 18 HP, 20 Amp Recharge, 1" Shaft w/Muf.	\$799.21
1830	Kohler, 22 HP, 25 Amp Recharge, 1-1/8" Shaft	\$1219.61
1831	Kohler, 25 HP, 25 Amp Recharge, 1" Shaft	\$1276.26
1832	Kohler, 27 HP, 25 Amp Recharge, 1-1/8" Shaft	\$1557.45
2888	Kohler, 28 HP, Water Cooled, 25 Amp, 1-1/8" Shaft Includes Control Module, Use Muffler #2340	\$1696.03
1833	Kohler, 28 HP, EFI Fuel Miser, 25 Amp, 1-1/8" Shaft	\$1912.37
1834	Kohler, 30 HP, 25 Amp Recharge, 1-1/8" Shaft	\$1783.49
1836	Kohler, 40 HP, 25 Amp Recharge, 1-7/16" Shaft	\$2481.80

**MUFFLERS**

1279	Kohler, 18-22 HP, Top Mount, Oil Filter Side	\$ 79.03
1280	Kohler, 18-22 HP, Top Mount, Starter Side	\$ 88.06
1282	Kohler, 18-22 HP, Low Mount, Oil Filter Side	\$109.91
1281	Kohler, 18-22 HP, Low Mount, Starter Side	\$ 99.75
1283	Kohler, 25-30 HP, Top Mount, Oil Filter Side	\$ 99.75
1284	Kohler, 25-30 HP, Top Mount, Starter Side	\$ 99.75
1286	Kohler, 25-27 HP, Low Mount Oil Filter Side	\$191.07
1285	Kohler, 25-27 HP, Low Mount Starter Side	\$191.07
2340	Kohler, 28 Water Cooled, Oil Filter Side	\$ 99.75

**KUB65 KUBOTA**  
**65 HP Diesel**  
**w/Shaft and Controls**



KUB65

**U-Pay Freight this Page**



## Kohler Engine Filters

PART #	Description	PRICE
1837	Long oil filter / Pro Series	\$ 7.41
1838	Short oil filter / Pro Series	\$ 7.62
1839	Fuel filter	\$ 6.66
1840	Air filter/Pre-Cleaner fits CH-25 & CH-27	\$7.79
1841	Pre-cleaner fits CH-25 & CH-27	\$ 3.07
1842	Air filter/Pre-Cleaner,CH-18, CH-20, CH-22	\$ 6.72
1843	Pre-cleaner fits CH-18, 20 & 22	\$ 3.07
3932	Donaldson Air Filter for Our 28 WC, 30 & 38	\$16.46
3933	Donaldson Safety Filter for 3932 above	\$19.16



## Honda & Briggs Filters

PART #	Description	PRICE
1613	Honda Air Filter for GC160	\$ 6.06
1614	Honda Air Filter for GX160 & GX 200	\$ 5.83
1615	Honda Air Filter for GX240 & GX270	\$ 5.78
1616	Honda Air filter for GX340 & GX390	\$ 6.88
1733	Vanguard Pre-cleaner	\$ 3.03
1734	Vanguard Oil Filter	\$ 7.51
1735	Vanguard Air Filter	\$12.90
1617	Honda Oil Filter for GX620 or GX670	\$ 8.70
1618	Honda Spark Plug for GC&GX4HP to 13HP	\$ 1.49
4701	Spark Plug Kohler Kohler 7 HP	\$ 6.90
4702	Spark Plug Kohler 14 & 18 & Vanguard 18	\$ 2.76
4703	Spark Plug Kohler 22, 25, 27, 28 & 30 HP	\$ 4.58
4704	Spark Plug Kohler 40 HP	\$12.70
4705	Spark Plug Kohler Agis Liquid Cooled	\$ 2.76
1619	Honda Dip Stick for GS260 & GX390	\$ 5.82
1620	Honda Dip Stick for GC135 & GX200	\$ 5.82

## Industrial Fuel Line



- 1/4" Thick Wall
- Priced per foot
- For Gas or Diesel

PART # / PRICE  
1196 \$ 7.79

## Throttle Cable Fits All Engines

- 36" Cable can be cut to fit
- For precise engine speed control
- Auto Pre-sets
- Push Pull or 'Snap' Pull and lock
- Designed for harsh, moist environments

PART # / PRICE  
1991 \$41.12



## Key-Way Stock Premium

- 1/4" key stock for engine shafts
- Super Hard



PART # PRICE  
3777 \$5.35

- Heat treated for longer life and higher horsepowers

- A MUST for gear drive systems

## Oil Drain Plug

PART # / PRICE  
1428 \$7.89

- For engines, pumps & gear boxes
- No more "messy" oil changes
- Simple to install easy to use
- Will not fit Honda



## NEW FROM KOHLER

Each kit has 2 quarts of oil, oil filter, air filter, pre-cleaner, fuel filter, and 2 spark plugs



### Complete Maintenance Kit



Change Oil...  
Engines 50 hrs.  
Pumps 500 hrs.  
Gear Box 500 hrs.

6440 \$39.53  
6441 \$39.53

- 6440 KIT Fits 18 HP bought from EnviroSpec
- 6441 KIT Fits all Kohlers 22 HP through 30 HP

## Universal Starter Solenoid

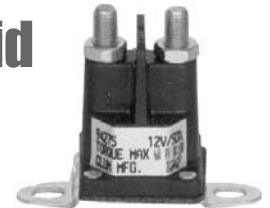

- For gas engines
- 5/16: double terminal

PART # / PRICE  
1427 \$8.86

- Same as used on Vanguards



Super Easy Installation!

## Tiny-Tach / Hour Meter

- Takes the "guess work" out of pressure washer problems
- #1429 works on all 1 & 2 cylinder GAS engines.
- #3407 is for DIESEL engines regardless of cylinders up to 10,000 RPM. It has a solid state, quartz crystal control.

PART #	DESCRIPTION / PRICE
1429	For Gas Engines \$ 33.77
3407	For Diesel Engines \$127.24

On this page we pay the freight on \$50.00 Web Orders or \$200.00 Call-in Orders



# ALLISON PREMIUM CART SYSTEMS

## REPLACEMENT CART FOR ANY 13 to 18 HP BELT DRIVE SYSTEM

- Aircraft Aluminum • Pre-drilled for most engines
- These are the finest replacement cart in the industry.

**9900** \$237.32  
This is a Belt Drive Frame  
10 x 25 x 3/8 Aluminum  
Pre-Drilled for Honda



**9901** \$197.12  
This is a Signature Gear Drive Frame  
10" x 30" x 1/4" Aircraft Aluminum  
Pre-Drilled for 18 thru 30 Kohlers

## BASE PLATE handles up to 30 HP Engines

- Handles engines up to 30 HP
- Pre-drilled for most engines
- Rubber feet provides shock absorption between unit and bed of truck/trailer.



PART # / PRICE  
1899 \$34.44

## Marine Battery Box



- High density plastic
- Tie-down hardware included
- Marine grade

PART #	DESCRIPTION / PRICE
1690	Large - Standard Size \$9.98
4690	Small - U1 - Tractor \$9.98

## Premium Battery Terminal

- Works on all battery cables
- Heavy duty lead construction
- Keep lubed with lithium grease

PART # / PRICE  
1825 \$1.49



## Replacement Gas Cap

- Fits all Honda GX series engines

PART # / PRICE  
1129 \$3.11



## Universal Key Switch

PART # / PRICE  
1430 \$18.45

- Fits all Engines
- ON/OFF/Start
- Springs back to "ON"
- Panel Mounts
- Two Keys included



Axle Caps

Round Foot



Molded Foot

## PREMIUM 2-WHEEL CART

- Includes:
- 100' Reel
  - Tool Tray
  - Hose Hanger
  - Vibration Mounts
  - 13" Premium Tires
  - Powder Coated Steel



#RC-101 \$163.58

## Replacement Cart Parts

PART #	DESCRIPTION / PRICE
1778	10" Foam filled, never flat tire/wheel \$12.44
1773	13" Pneumatic Tire/wheel for 3/4" Axle \$16.87
1779	13" Foam filled, never flat tire/wheel \$23.89
2330	<i>Best Buy - Normally sells for \$47.80</i> 13" Premium Mag never flat tire/wheel \$23.90
1774	Axle Cap, nickel, fits 5/8" axle \$ .89
1775	Axle Cap, nickel, fits 3/4" axle \$ .97
1776	Rubber Foot, round \$ .86
1777	Molded Rubber Foot \$ .94





Are you up to Code  
or are you using a 5 gallon  
'soap bucket' as your Gas Can?  
**BE SAFE - NOT SORRY**

**Plumbed to fit all  
'tankless' pressure washers**

**#4121 \$48.62**



**9-GALLON  
FUEL TANK**

**ALLISON  
24 GALLON  
FUEL TANKS**

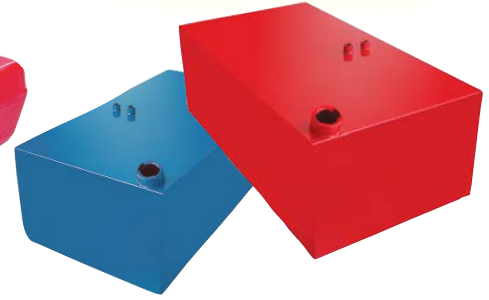

Mounting Hardware, Cap  
and Fuel Pick-up Tube included

Includes 1/4" Bottom Drain

31.5" Long 17" Wide 11" High

PART #	DESCRIPTION	PRICE
9400	RED 24 Gallon Tank for GAS ONLY	\$176.19
9401	BLUE 24 Gallon Tank for Diesel & Kerosene	\$176.19



**WIRE LOOM**

• No more  
tangled electrical wires

PART #	DESCRIPTION / PRICE
4455	1/4" X 8 FEET \$3.70
4457	1/2" X 8 FEET \$4.80
4458	5/8" X 8 FEET \$5.20

**RUBBER  
CLIPS**



Eliminates hose wear  
due to vibration

PART #	DESCRIPTION/PRICE
95302	1/4" \$ .76
95304	3/8" \$ .76
95306	1/2" \$ .98
95310	3/4" \$1.08
95314	1.0" \$1.29
95318	1-1/4" \$1.94
95322	1-1/2" \$2.41

**Hard to Find...  
'Corrosion Factor 1000'  
Industrial Hose Clamp**



1/2"  
HI-TORQUE  
BAND



**ACID RESISTANT  
'316' Satinless Steel**

PART #	DESCRIPTION	PRICE
90014	1/4" - 9/16"	\$2.75
90017	7/16" - 11/16"	\$3.19
90024	5/8" - 15/16"	\$3.33
90032	1" - 1-1/4"	\$3.84

**DUAL PUMPER FRAME**

Pre-drilled for the following:

- 18-40 HP Kohler
- Dual or Single Pump Drive
- Dual or Single Pump Adjusters
- Generator with Single Pump



- Dual or Single Chem Induction Systems
- Oil Drain Holes
- Tank Sold Separately
- Includes Battery Box
- Belt Guard

**#9997 \$797.83**

**ENGINE THROTTLE DOWN**

- Idles the engine down when you release the trigger.
- Returns to full throttle when the trigger is pulled.
- Not to be used on hot water machines equipped with a generator.

PART # / PRICE  
1665 \$32.03





## Gear Boxes

- Fits 1450 RPM Pumps with 24MM Pump Shaft & reduces pump speed to 1450 RPM when installed on a 3600 RPM Engine.



PART #	For 1450 RPM Pumps that have a 24MM Shaft	PRICE
5320	UDOR Gear Box for 1-1" Shaft PREMIUM GEAR BOX - <b>Used on Iron Horse</b> Use on Engines up to 30 HP	\$229.84
5321	UDOR Gear Box for 1-1/8" Shaft PREMIUM GEAR BOX - <b>Used on Iron Horse</b> Use on Engines up to 30 HP	\$229.84
1028	'PA' Dual Bearing Heavy Duty Gear Box 1" Eng Shaft Use on Engines up to 30 HP	\$219.97
1029	'PA' Dual Bearing Heavy Duty Gear Box 1-1/8" Shaft Use on Engines up to 30 HP	\$219.97

## Pump Pulleys and Bushings

To help you select the right pulley and bushing here are a few combinations that we recommend.

### 12 Volt with a...

1450 RPM Pump Pulley	= 8.40
1750 RPM Pump Pulley	= 7.40
Pump Pulley Bushing*	= 24mm
Engine Pulley for 1450	= 3.40
Engine Pulley for 1750	= 3.60
Engine Pulley Bushing**	= 1"

\*assuming the pump has a 24mm shaft  
\*\*assuming the engine has a 1" shaft



Part #	Pulley Size	Price
1654	3.00 - 2-Groove "B"	\$42.35
1655	3.20 - 2-Groove "B"	\$42.35
1656	3.40 - 2-Groove "B"	\$42.35
1658	3.60 - 2-Groove "B"	\$42.35
1659	3.90 - 2-Groove "B"	\$42.35
1661	6.40 - 2-Groove "B"	\$42.35
1662	7.40 - 2-Groove "B"	\$60.37
1663	8.40 - 2-Groove "B"	\$68.85

Here is the way you determine the correct pulley size. First you need to determine the pump manufacturers recommended rpm. Then you have to remember that the gas engine runs at 3600 rpm. So here we go.

Let's say you have a 3.40 engine pulley and you want to find the correct pump pulley.  $3.40 \times \text{engine speed (3600 rpm)} = 12240$  then divide by the pump rpm (let's say 1450) = 8.44 pump pulley. What they don't make a 8.44? Just get close. In this case get the 8.4 pulley size.

You can figure any pulley size you need just by knowing 3 of the four questions. 1: Pump RPM 2. Pump Pulley Size 3. Engine RPM & 4. Engine Pulley Size. Any 3... ex. 1 x's 2 divided by 3 = 4 / 3 x's 4 divided by 1 - 2

Part #	Required Bushings	Price
1025	5/8" For Engine	\$11.37
1026	1.0" For Engine	\$11.37
1027	1-1/8 For Engine	\$11.37
1032	20mm For Pump	\$11.37
1033	24mm For Pump	\$11.37
1034	32mm For Pump	\$11.37



## GET 10 TIMES THE LIFE OUT OF YOUR PUMP

## JUST BY INSTALLING THIS 12V CLUTCH

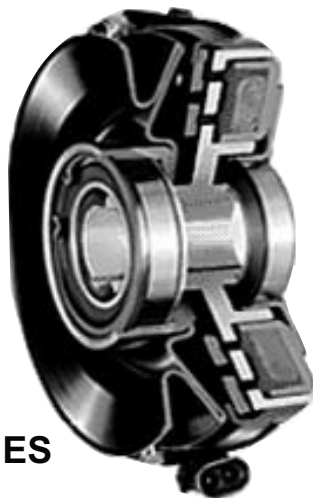

FOR GAS ENGINES UP TO 22 HP

PART #	PRICE
9333	\$215.76

You will absolutely love...  
...this set-up!

*Super Easy Call for Instructions on this...  
super easy Install!*



## PULLEY-PULLER

I'll bet there have been times when you wish you had one of these!

PART #	PRICE
3342	\$17.83



# OIL CAPS



**PART # DESCRIPTION / PRICE**

- 1882 OIL DIP STICK, GENERAL PUMPS \$11.87
- 1880 OIL CAP, CAT, PUMPS 5DX, 66DX, 5CP \$14.16
- 1881 OIL CAP, CAT, PUMPS 2SF, 4SF, 2DX \$12.16

# Gauge Port Valve Cap

- Mount the gauge on the pump



**PART # DESCRIPTION / PRICE**

- 1060 For EZ General Pumps \$19.46
- 1061 For TS2021, TS1511, all T & TS Generals \$19.46

# Replacement Site Glass



**PART # DESCRIPTION / PRICE**

- 1689 OIL LEVEL INDICATOR, General Pumps T & TS Series 47 (TS-2021) - T991 Series, TT & TP Series \$9.89
- 1421 TSF Series General Pumps \$9.89

# TALL PUMP RAILS

**PUMP RAILS  
HEAVY DUTY**  
For Gas Engine  
Pressure Washers



#1653 \$29.95

# ALLISON PUMP SAVER

**FOR "DC" CURRENT ONLY  
DO NOT INSTALL ON AC CURRENT**



**PART # / PRICE**

- 1990 \$14.65

- Shuts engine down before the pump head overheats & destroys the packings.
- Hooks to the pump inlet and senses incoming "by-pass" water temperature. If the water reaches 145°F the Terminator "kills" the engine.
- Keep in mind if you leave the trigger gun in the "off" position for more than 3 minutes chances are the pump head has already reached 145°F

# Pump Oil

Ideal for high pressure pumps. Non detergent and non foaming. Specially formulated and rated for superior rust protection and oxidation protection. Not for use in engine.



**PART # DESCRIPTION / PRICE**

- 1064 GENERAL PUMP OIL, 6 PACK / 16 OZ. BOTTLES \$24.93
- 1065 GENERAL PUMP OIL, 24 PACK / 16 OZ. BOTTLES \$99.36
- 4788 CAT CRANKCASE OIL - 21 OZ. BOTTLE \$10.36

Fill oil half-way on the indicator site glass only.



Note: Change oil after the first 50 hours of operation, then every 3 months or as needed.

# Tape - Teflon/Electrical

- Professional quality



**PART # DESCRIPTION / PRICE**

- 1651 TAPE, TEFLON 520' x 1/2" \$0.49
- 2151 **USA PREMIUM TEFLON**, 520' x 1/2" \$1.48
- 1601 TAPE, ELECTRICAL, 3/4" X 60', UL \$0.95

# Thread Locker



- Seal and Locks Fittings & Plumbing
- The Name Brand goes for \$139.99

**PART # DESCRIPTION / PRICE**

- 1057 THREAD LOCKER, MEDIUM \$45.81
- 1058 THREAD LOCKER, HIGH STRENGTH \$45.81

# Sewer Jetting Valves for General Pumps

- Increase your service by turning your General Pump into a sewer jetting machine.
- Simply remove the center high pressure valve cap & check valve and install the jetter valve in it's place.
- Then when you want a jetter turn the knob and the jetter hose will start pulling itself along.



**PART # DESCRIPTION**

- 1004 For TT Series General Pumps \$69.35
- 1005 For EZ Series General Pumps \$69.35
- 1006 For T & TS General Pumps \$69.35
- 3340 For TSF Series General Pumps \$69.35

Call for other brands of pumps.

On this page we pay the freight on \$50.00 Web Orders or \$200.00 Call-in Orders



## Value Kit #1

Part Number **2035** \$325.17

### GENERAL PUMPS

- 6 Hi-Temp Check Valves
- 3 Complete Sets of Hi-Temp Packings
- 3 Sets of Packing Brass
- 3 Ceramic Coated Pistons (packings and brass are pre-assembled)

#### Fits These Pumps

TS-2021, TS2011, T9131, T1011, T9161, T1511, T9211, T2031, TS1021, TS1011, TS1331, TS1511, TS1711, TS821



## Value Kit #2

Part Number **2036** \$289.12

### GENERAL PUMPS

- 6 Check Valves
- 3 Complete Sets of Standard Packings
- 3 Sets of Packing Brass
- 3 Ceramic Coated Pistons (packings and brass are pre-assembled)

#### Fits These Pumps

TS-2021, TS2011, T9131, T1011, T9161, T1511, T9211, T2031, TS1021, TS1011, TS1331, TS1511, TS1711, TS821

## Pump Head Pressure Tester

PART #1229

\$69.59



A **'MUST HAVE' TOOL!**

- Not sure why you are losing pressure
- Remove Unloader and attach direct to head
- INSTALL CORRECTLY SIZED NOZZLE
- Hold trigger securely and start engine and see exactly what your pump is capable of producing

## HIGH TEMP CHECK VALVES

#2034 - \$94.63

The same as a Kit 1 General except it is rated for 185°



Fits: TS2021, TS1011, TS1321, TS1331, TS1511, TS1021, TS1621, TS1711, TS2011, TS821, TT9111, TT941, TT9351, TT9441, TT2028G, TT2028E, TT2035, TT9061, TT9071, T9051, T9721, T9731, T9791, T721, T731, T991, T9951, T9971, T921, T9131, T1011, T1321, 59161, T1511, T1621, T1631, T9211, T2011, T2031, T9281, T9051EBF,

## Pressure Gauges

- Stainless Steel case • 2-1/2" Face
- Bottom 1/4" Mount • Glycerine filled

PART #	DESCRIPTION	
1130	PRESSURE GAUGE, 3,000 PSI	\$9.73
1131	PRESSURE GAUGE, 4,500 PSI	\$9.73
1132	PRESSURE GAUGE, 6,000 PSI	\$9.73
1133	PRESSURE GAUGE, 10,000 PSI	\$9.73

## Value Kit #3

Part Number **2037** \$168.71

### GENERAL PUMPS

- 6 Hi-Temp Check Valves
- 3 Complete Sets of Hi-Temp Packings
- 3 Sets of Packing Brass (packings and brass are pre-assembled)

If you are having a pressure problem you can usually tell if it is the 'check valve' by feeling and watching the high pressure hose. Worn or damaged 'check valves' will cause the hose to vibrate.

#### Fits These Pumps

TS-2021, TS2011, T9131, T1011, T9161, T1511, T9211, T2031, TS1021, TS1011, TS1331, TS1511, TS1711, TS821

## Value Kit #4

Part Number **2038** \$132.83

### GENERAL PUMPS

- 6 Standard Check Valves
- 3 Complete Sets of Standard Packings
- 3 Sets of Packing Brass (packings and brass are pre-assembled)

Large Frame pumps (over 30 lbs) can handle 145-160° head temperature while smaller pumps handle 130°.

A pump will see temps around 175° if you allow the machine to run for more than 3 minutes without pulling the trigger.

#### Fits These Pumps

TS-2021, TS2011, T9131, T1011, T9161, T1511, T9211, T2031, TS1021, TS1011, TS1331, TS1511, TS1711, TS821

## 'QC' Pressure Test Tool

- Connect between the unloader and hose
- 6,000 PSI



Shown in Brass but actually come in Stainless Steel



PART #	DESCRIPTION	
4505	STAINLESS STEEL BODY - NO GAUGE	\$ 8.78
4506	STAINLESS STEEL BODY w/GAUGE	\$12.97

## Ceramic Coated Pistons

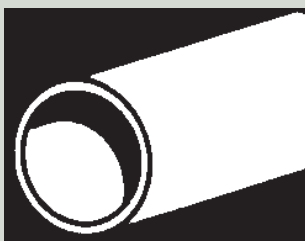

PART #	DESCRIPTION	
<b>20mm Piston fits:</b>		
1068	TS-2021, T1011, T1311, T1511, T2011, T2031, T9121, T9131, T9161, T9211, TS821, TS1011, TS1021, TS1041, TS1311, TS1331, TS1351, TS1511, TS1521, TS1531, TS1711, TS2011	\$54.84
<b>20mm Piston fits:</b>		
1069	TS21, TS31, T701, T711, T721, T731, T911, T981, T9721, T9731, T9791, T991, T9951, T9961, T9971	\$23.16
<b>15mm Piston fits:</b>		
1070	EZ3040G, EZ2545G, EZ3035G, EZ2545E, EZ3040S, TT9441, TX1505G6, TX1506G6, TX1508G6, TX1508G8, TX1509G8, TX1510G8	\$23.16
<b>22mm Piston fits:</b>		
1071	T921, T1321, T1621, T1631, T921, TS1321, TS1621	\$23.16





**WORLD LEADER IN PLUNGER PUMPS**

# PLUNGER PUMPS

Without a doubt...  
...the best money can buy!

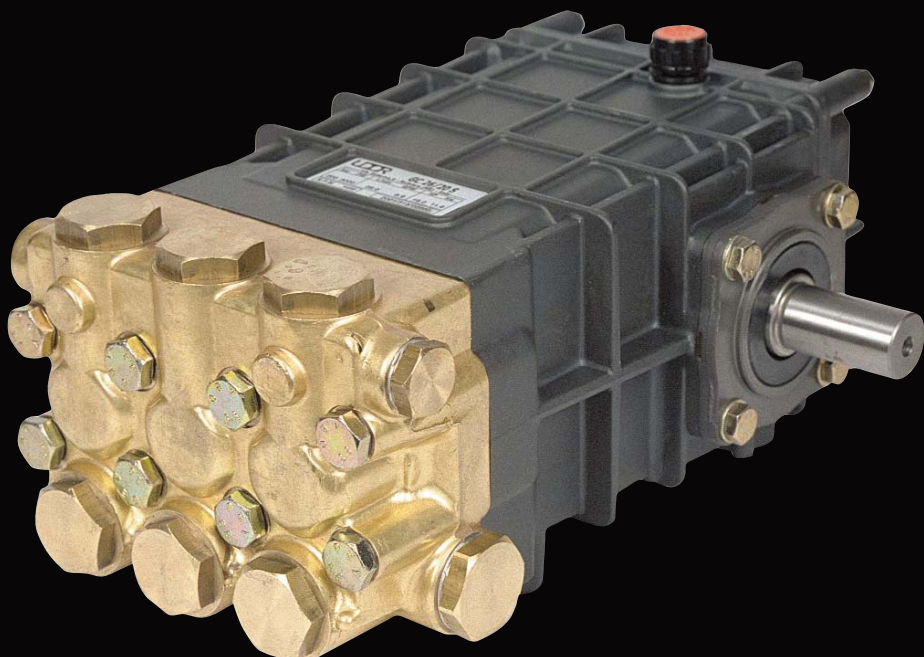

GC2120GR	\$610.60	GKCW3814S	\$656.80
GC2120GR118	\$610.60	GKD5540S	\$583.30
GC2120E	\$526.60	GKD5550S	\$789.10
GC2120EL	\$526.60	GKD7035S	\$602.20
GC2620GR	\$633.70	GKD7045S	\$797.50
GC2620GR118	\$633.70	GSC2715S	\$2,503.63
GC2620S	\$484.60	GSC3415S	\$2,503.63
GC3017GR	\$652.60	GSC4215S	\$2,503.63
GC3017GR118	\$652.60	MC1320S	\$314.50
GC3017S	\$499.30	MC1520GR	\$480.40
GC3815GR	\$713.50	MC1520S	\$314.50
GC3815GR118	\$713.50	MC1820S	\$333.40
GC3815S	\$560.20	MD4020S	\$314.50
GD5530S	\$459.40	MD4020U	\$339.70
GD7022S	\$484.60	MD4030S	\$314.50
GD8022S	\$499.30	MD4030U	\$339.70
GD8022SL	\$499.30	MD40L	\$339.70
GHC1250GR	\$1,578.70	MD5025S	\$333.40
GHC1250GR118	\$1,578.70	MD5025SL	\$320.80
GHC1250S	\$1,387.60	MD5025U	\$350.20
GHC1650GR	\$1,578.70	MD5025UL	\$350.20
GHC1650GR118	\$1,578.70	MD5030U	\$375.40
GHC1650S	\$1,387.60	MKC1328S	\$362.80
GHD3075S	\$1,387.60	MKC1528S	\$362.80
GHD4575S	\$1,387.60	MKC1824S	\$381.70
GKC1230GR	\$868.90	MKC2024S	\$394.30
GKC1728GR	\$726.10	MKCW3100	\$560.20
GKC1728GR118	\$726.10	MKD4030U	\$400.60
GKC1728S	\$572.80	MKD4030UL	\$503.50
GKC1735GR	\$942.40	MKD4040S	\$362.80
GKC1735GR118	\$942.40	MKD4530U	\$503.50
GKC1735S	\$789.10	MKD4530UL	\$503.50
GKC1940GR	\$1,139.80	MKD5035S	\$381.70
GKC1940GR118	\$1,139.80	MKL3540W	\$362.80
GKC1940S	\$980.20	MKL4040W	\$362.80
GKC2128GR	\$736.60	MKL4040WL	\$362.80
GKC2128GR118	\$736.60	MKL5035W	\$381.70
GKC2128S	\$583.30	ML3530W	\$304.00
GKC2135GR	\$955.00	ML3530WL	\$304.00
GKC2135GR118	\$955.00	ML3535W	\$354.40
GKC2135S	\$797.50	ML4030W	\$304.00
GKC2624GR	\$753.40	ML4030WL	\$304.00
GKC2624GR118	\$753.40	ML4035W	\$354.40
GKC2624S	\$602.20	ML5030W	\$320.80
GKC2628GR	\$770.20	MSC1615S	\$1,522.00
GKC2628GR118	\$770.20	MSC2015S	\$1,522.00
GKC2628S	\$614.80	PC1117S	\$245.20
GKC3020GR	\$772.30	PC1315S	\$245.20
GKC3020GR118	\$772.30	PD1020Z	\$243.10
GKC3020S	\$616.90	PD1520Z	\$243.10
GKC3024GR	\$816.40	PD2020Z	\$243.10
GKC3024GR118	\$816.40	PD3015ZA	\$207.40
GKC3024S	\$637.90	PD3020S	\$243.10
GKC3817GR	\$795.40	PD3020Z	\$245.20
GKC3817GR118	\$795.40	PD3020ZL	\$245.20
GKC3817S	\$642.10	PD3520S	\$245.20
GKC3817SL	\$642.10	PD4015S	\$245.20
GKC3820GR	\$835.30	PD4015T	\$278.80
GKC3820GR118	\$835.30	PD4015Z	\$249.40
GKC3820S	\$656.80	PDCW4015S	\$245.20
GKC4215GR	\$816.40	PDCW4015Z	\$249.40
GKC4215GR118	\$816.40	PL2020Z	\$243.10
GKC4215S	\$656.80	PL2020ZL	\$243.10
GKC4215SL	\$656.80	PL2520T	\$243.10
GKC5012GR	\$835.30	PL2525TV	\$287.20
GKC5012GR118	\$835.30	PL3020T	\$243.10
GKC5012S	\$682.00	PL3020Z	\$245.20
GKCW1814S	\$602.20	PL3020ZL	\$245.20
GKCW2114S	\$616.90	PL3025T	\$249.40
GKCW3014S	\$642.10	PL3522T	\$249.40

Here is your crossover for pumps that fall into the  
**5.5 GPM @ 3,500 PSI Series**

A-R	RW-21	5.5 @ 3500 PSI	Weighs 31 lbs.
CAT	7F-59	5.5 @ 3500 PSI	Weighs 29 lbs.
COMET	RW5535S	5.5 @ 3500 PSI	Weighs 27 lbs.
GENERAL	TS2021	5.6 @ 3500 PSI	Weighs 32 lbs.
UDOR	GC2120-E	5.5 @ 3500 PSI	Weighs 36 lbs.

**U-Pay Freight on Pumps**



For the Specifications of any pump please visit our web site

<http://www.envirospec.com>

or call  
1-800-346-4876



## DIAPHRAGM PUMPS

Without a doubt...  
...the best money can buy!

B110CC	\$1,683.81	K40WOC	\$391.63
B150CC	\$2,060.98	K43	\$487.59
B200CC	\$2,877.80	K43GR	\$704.08
B240CC	\$2,949.22	K43GRWOC	\$623.74
I18E	\$329.15	K43WOC	\$391.63
I18M	\$650.52	K53	\$503.22
I20	\$329.15	K53GR	\$797.81
I20GR	\$429.57	K53GR8	\$824.59
I20GR58	\$429.57	K53WOC	\$405.03
I20GRV	\$447.42	K55	\$639.35
I20H	\$532.23	K55GR5	\$860.30
I20M220V	\$690.69	K55GR5WOC	\$762.11
K100	\$936.18	K55GR8	\$911.63
K100C	\$911.63	K55GR8WOC	\$813.43
K100CC	\$989.74	K55TS	\$688.45
K100CIND	\$940.65	K55WOC	\$545.62
K100CWOC	\$784.42	K7115V	\$576.86
K100CWOD	\$846.91	K712V	\$485.37
K100GR	\$1,311.12	K712VHP	\$639.35
K100TS	\$989.74	K75	\$820.13
K100VAIND	\$1,027.68	K75CC	\$882.62
K100WOC	\$811.20	K75GR	\$1,094.63
K120CC	\$1,471.80	K75GRWOC	\$971.89
K120GR	\$1,889.13	K75TS	\$882.62
K120TS	\$1,534.29	K75WOC	\$695.15
K150CC	\$1,690.51	K7DC	\$259.96
K150GR	\$2,054.28	O140CC	\$1,460.64
K150GRASSY	\$5,263.54	O170CC	\$1,692.74
K150TS	\$1,750.77	R110	\$683.99
K1512V	\$485.37	R1102S	\$683.99
K1512VHP	\$610.35	R110C	\$663.91
K15CS	\$262.19	R110GR	\$962.96
K15DC	\$259.96	R130C	\$692.92
K15GR	\$355.93	R160C	\$1,045.53
K15GR58	\$355.93	R160CC	\$1,052.23
K15GR58CI	\$507.69	R160H	\$1,125.88
K15GRCI	\$507.69	R210CC	\$1,346.82
K1812V	\$507.69	R250CC	\$1,384.76
K18DC	\$284.51	R250H	\$1,451.71
K25	\$420.64	R320CC	\$1,701.67
K2512V	\$1,668.20	R70	\$489.83
K25GR	\$483.13	R70115V	\$1,619.10
K25WOC	\$320.22	R7012V	\$1,619.10
K30	\$474.20	R70GR5	\$721.93
K30115V	\$1,574.46	RP4401D	\$188.54
K3012V	\$1,574.46	Z40E	\$619.27
K30GR	\$695.15	Z40EGR5	\$826.82
K30WOC	\$378.24	Z40GRWOC	\$1,020.99
K33	\$474.20	Z40P	\$873.69
K3312V	\$1,996.26	Z40PGR	\$1,099.09
K33GR	\$697.38	Z40PGRWOC	\$1,020.99
K33WOC	\$396.10	Z40PWOC	\$777.72
K40	\$487.59	Z85	\$668.37
K40115V	\$1,574.46	Z85C	\$492.06
K4012V	\$1,574.46	Z85GR5	\$873.69
K40GR	\$704.08	Z85P	\$933.94
K40GRWOC	\$619.27	Z85PGR5	\$1,154.89
K40TS	\$514.38	Z85WOC	\$512.29

## REPAIR KITS FOR ALL UDORS

UD1	\$57.87	UD33	\$57.15
UD10	\$70.63	UD37	\$10.00
UD106	\$42.70	UD38P	\$85.60
UD107	\$10.00	UD3P	\$127.72
UD10P	\$130.81	UD3PPV	\$135.33
UD11	\$72.37	UD3PV	\$87.34
UD111	\$133.06	UD4	\$20.91
UD112	\$129.19	UD40	\$24.97
UD113	\$22.71	UD41	\$88.24
UD114	\$178.09	UD42	\$70.38
UD115	\$30.39	UD5	\$21.87
UD116	\$115.92	UD6	\$47.86
UD117	\$123.91	UD63	\$83.92
UD119	\$93.34	UD63P	\$161.91
UD11P	\$138.42	UD64	\$81.40
UD12	\$74.37	UD65	\$65.22
UD123	\$25.48	UD70	\$173.25
UD12P	\$146.04	UD71	\$127.72
UD13	\$51.99	UD72	\$142.93
UD14	\$52.90	UD78P	\$84.88
UD15	\$52.90	UD8	\$67.21
UD16	\$59.02	UD80P	\$130.81
UD17	\$66.45	UD85	\$44.64
UD17P	\$123.21	UD85P	\$81.99
UD18	\$68.38	UD86	\$187.18
UD18P	\$130.81	UD86P	\$444.42
UD19	\$70.38	UD87	\$121.92
UD19P	\$138.42	UD87P	\$183.00
UD2	\$60.00	UD88	\$316.77
UD20	\$20.91	UD88P	\$485.88
UD28	\$67.21	UD8B	\$10.00
UD28B	\$69.99	UD9	\$69.28
UD29	\$52.90	UD93	\$129.52
UD3	\$66.96	UD94	\$147.13
UD30	\$63.22	UD95	\$156.28
UD31	\$69.28	UD96	\$157.65
UD31P	\$135.33	UD97	\$161.19
UD31PPV	\$142.93	UD98	\$161.19
UD31PV	\$82.95	UD99	\$185.77
UD32	\$20.91	UD9P	\$123.21

# DIAPHRAGM



## UDOR DIAPHRAGM PUMP FEATURES

- Over 40 Years Of Diaphragm Pump Experience.
- One Piece Stainless Steel Diaphragm Bolts.
- Heavy Duty Pre-Formed Urethane Diaphragms.
- Can Be Run Dry.
- Visual Oil Sight Gauges.
- Self-Priming Operation.
- Stainless Steel Check Valves.
- Large Capacity Oil Bath Crank Cases
- Compatible with Most Fluids
- Adapt Easily To PTO, Gas Engine, Hydraulic & Belt Drive Applications.
- Maximum Fluid Temperature, 140° F.
- Custom Pumps Available To 200° F.
- Largest Selection of Flows, Pressures & Drive Options Available.

## APPLICATIONS INCLUDE:

- Chlorine Roof Cleaning
- Lawn Care • Pest Control
- Crop Spraying • Hydrostatic Testing
- Air Craft De-Icing • Spray Insulation
- Ground and Sod Aeration
- De-Mucking • Pressure Washing
- Sewer Jetting • Car/Truck Washing
- Tree Debarking • Reverse Osmosis
- Mist Cooling • Food Processing

## UDOR Seal Design - Technology Makes It Better!

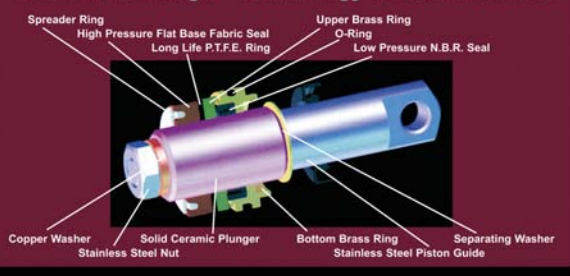



# SUPER DUTY MK-Series High Pressure Plunger Pumps

- Heavy Duty Bronze or High Strength Aluminum Alloy Connecting Rod Assemblies 1 lb. each
- Heavy Duty Reinforced Brass Heads with External and Internal Bracing
- Large Diameter Stainless Steel Valve Caps with Increased Thread Depth
- Reinforcing Ring on Inlet and Discharge Ports
- Deeper Back Covers for Increased Oil Capacity. 28 oz. Crank Case Capacity



## Solid Shaft Models

*24 mm Keyed, Solid Shaft*

	MODEL	GPM	PSI	POWER REQUIREMENTS	SEAL KIT	VALVE KIT	WEIGHT
<b>1450 RPM</b>	MKC 13/28-S	3.5	4000	10 HP Electric	UD-28	UD-30	27 lbs.
	MKC 15/28-S	4.0	4000	10 HP Electric	UD-28	UD-30	27 lbs.
	MKC 18/24-S	5.0	3500	12.5 HP Electric	UD-9	UD-30	27 lbs.
	MKC 20/24-S	5.5	3500	15 HP Electric	UD-9	UD-30	27 lbs.
<b>1750 RPM</b>	MKD 4.0/40-S	4.0	4000	10 HP Electric	UD-28	UD-30	27 lbs.
	MKD 5.0/35-S	5.0	3500	12.5 HP Electric	UD-28	UD-30	27 lbs.
<b>Rail Kits</b>	8702.10	Standard ( 7/8" ) Rail Kit for MK-Series Solid Shaft Pumps					
	8702.20	Tall ( 2-1/2" ) Rail Kit for MK-Series Solid Shaft Pumps					



## Direct Drive, Gas Engine Flange Models

*1" Hollow Shaft with Mounting Flange and Set Screw*

	MODEL	GPM	PSI	POWER REQUIREMENTS	SEAL KIT	VALVE KIT	WEIGHT
<b>3400 RPM</b>	MKL 3.5/40-W	3.5	4000	14.5 HP Gas	UD-7	UD-30	28 lbs.
	MKL 4.0/40-W	4.0	4000	16 HP Gas	UD-7	UD-30	28 lbs.
	MKL 5.0/35-W	5.0	3500	16 HP Gas	UD-28	UD-30	28 lbs.



## Gear Reduction Drive, Gas Engine Model

*1" or 1-1/8" Hollow Shaft (Please Specify) • 2.2:1 Gear Reduction*

	MODEL	GPM	PSI	POWER REQUIREMENTS	SEAL KIT	VALVE KIT	WEIGHT
<b>Gear Reduction</b>	MKC 13/28-GR	3.5	4000	14.5 HP Gas	UD-28	UD-30	37 lbs.
	MKC 15/28-GR	4.0	4000	16 HP Gas	UD-28	UD-30	37 lbs.
	MKC 18/24-GR	5.0	3500	16 HP Gas	UD-9	UD-30	37 lbs.
	MKC 20/24-GR	5.5	3500	18 HP Gas	UD-9	UD-30	37 lbs.



# SUPER DUTY MK-Series High Pressure Plunger Pumps



MKD 4.5/30-UL

## Direct Drive, Electric Flange Models

1-1/8" Hollow Shaft with 182/184 Mounting Flange and Set Screw



MKD 4.0/30-U

	MODEL	GPM	PSI	POWER REQUIREMENTS	SEAL KIT	VALVE KIT	WEIGHT
<b>1750 RPM</b>	MKD 4.0/30-U	4.0	3000	7.5 HP Electric	UD-28	UD-30	30 lbs.
	MKD 4.5/30-UL	4.5	3000	10 HP Electric	UD-9	UD-30	30 lbs.

# G-Series High Pressure Plunger Pumps

- 13" L x 9-3/4" W x 5-1/2" H (Solid Shaft Model)
- Brass Manifold
- Heat Treated Crankshaft
- Stainless Steel Piston Guides
- Replaceable Teflon Coated Body Guides
- High Strength Aluminum Alloy Connecting Rods with Guide Pins for Perfect Cap Alignment - 1 lb each
- Industrial Quality Tapered Roller Bearings
- Max. Fluid Temp. 160°F
- 3/4" Inlet 3/8" Outlet
- Solid Ceramic Plungers
- Stainless Steel Check Valves
- Heavy Duty Flat Base High Pressure Seals
- 40 oz. Capacity Vented Oil Bath Crank Case



## Solid Shaft Models

24 mm Keyed, Solid Shaft

	MODEL	GPM	PSI	POWER REQUIREMENTS	SEAL KIT	VALVE KIT	WEIGHT
<b>1450 RPM</b>	GC 21/20-S E	5.5	30(3500)	12.5 HP Electric	UD-10	UD-3	36 lbs.
	GC 26/20-S	7.0	3000	15 HP Electric	UD-10	UD-3	36 lbs.
	GC 30/17-S	8.0	2500	15 HP Electric	UD-11	UD-3	36 lbs.
	GC 38/15-S	10.0	2200	15 HP Electric	UD-12	UD-3	36 lbs.
<b>1750 RPM</b>	GD 5.5/30-S	5.5	3000	12.5 HP Electric	UD-10	UD-3	36 lbs.
	GD 7.0/22-S	7.0	2200	10 HP Electric	UD-10	UD-3	36 lbs.
	GD 8.0/22-S	8.0	2200	10 HP Electric	UD-10	UD-3	36 lbs.
<b>Rail Kits</b>	8702.07	Medium ( 1-3/4" ) Rail Kit for G-Series Solid Shaft Pumps					
	8702.08	Standard ( 1" ) Rail Kit for G-Series Solid Shaft Pumps					
	8702.25	Tall ( 2-1/2" ) Rail Kit for G-Series Solid Shaft Pumps					





# G-Series High Pressure Plunger Pumps



## Gear Reduction Drive, Gas Engine Models

1" or 1-1/8" Hollow Shaft (Please Specify)

2.2:1 Gear Reduction

	MODEL	GPM	PSI	POWER REQUIREMENTS	SEAL KIT	VALVE KIT	WEIGHT
<b>Gear Reduction</b>	GC 21/20-GR	5.5	3000	16 HP Gas	UD-10	UD-3	46 lbs.
	GC 26/20-GR	7.0	3000	20 HP Gas	UD-10	UD-3	46 lbs.
	GC 30/17-GR	8.0	2500	20 HP Gas	UD-11	UD-3	46 lbs.
	GC 38/15-GR	10.0	2200	20 HP Gas	UD-12	UD-3	46 lbs.

# SUPER DUTY GK-Series High Pressure Plunger Pumps

- Heavy Duty Bronze Connecting Rod Assemblies with Guide Pins for Perfect Cap Alignment 2 lbs. each.
- Heavy Duty Reinforced Brass Heads with External and Internal Bracing • Reinforcing Ring on Inlet and Discharge Ports
- Large Diameter Stainless Steel Valve Caps with Increased Thread Depth
- Deeper Back Covers for Increased Oil Capacity. 40 oz. Crank Case Capacity



## Solid Shaft Models

24 mm Keyed, Solid Shaft

	MODEL	GPM	PSI	POWER REQUIREMENTS	SEAL KIT	VALVE KIT	WEIGHT
<b>1450 RPM</b>	GKC 17/28-S	4.5	4000	12.5 HP Electric	UD-10	UD-31	39 lbs.
	GKC 21/28-S	5.5	4000	15.0 HP Electric	UD-10	UD-31	39 lbs.
	GKC 26/24-S	7.0	3500	17.0 HP Electric	UD-10	UD-31	39 lbs.
	GKC 26/28-S	7.0	4000	20.0 HP Electric	UD-10	UD-31	40 lbs.
	GKC 30/20-S	8.0	3000	17.0 HP Electric	UD-11	UD-3	39 lbs.
	GKC 30/24-S	8.0	3500	20.0 HP Electric	UD-11	UD-3	40 lbs.
	GKC 38/17-S	10.0	2500	17.0 HP Electric	UD-12	UD-3	39 lbs.
	GKC 38/20-S	10.0	3000	20.0 HP Electric	UD-12	UD-3	40 lbs.
	GKC 42/15-S	11.5	2200	17.0 HP Electric	UD-12	UD-3	39 lbs.
	GKC 50/12-S	12.5	2000	17.0 HP Electric	UD-12	UD-3	39 lbs.
<b>1750 RPM</b>	GKD 5.5/40-S	5.5	4000	15.0 HP Electric	UD-10	UD-31	39 lbs.
	GKD 7.0/35-S	7.0	3500	17.0 HP Electric	UD-10	UD-31	39 lbs.
<b>Rail Kits</b>	8702.07	Medium ( 1-3/4" ) Rail Kit for GK-Series Solid Shaft Pumps					
	8702.08	Standard ( 1" ) Rail Kit for GK-Series Solid Shaft Pumps					

**U-Pay Freight this Page**





# SUPER DUTY GK-Series High Pressure Plunger Pumps



## Gear Reduction Drive, Gas Engine Models

1" or 1-1/8" Hollow Shaft (Please Specify)

2.2:1 Gear Reduction

	MODEL	GPM	PSI	POWER REQUIREMENTS	SEAL KIT	VALVE KIT	WEIGHT
<b>Gear Reduction</b>	GKC 17/28-GR	4.5	4000	16 HP Gas	UD-10	UD-31	49 lbs.
	GKC 21/28-GR	5.5	4000	20 HP Gas	UD-10	UD-31	49 lbs.
	GKC 26/24-GR	7.0	3500	22 HP Gas	UD-10	UD-31	49 lbs.
	GKC 26/28-GR	7.0	4000	24 HP Gas	UD-10	UD-31	55 lbs.
	GKC 30/20-GR	8.0	3000	22 HP Gas	UD-11	UD-3	49 lbs.
	GKC 30/24-GR	8.0	3500	24 HP Gas	UD-11	UD-3	55 lbs.
	GKC 38/17-GR	10.0	2500	22 HP Gas	UD-12	UD-3	49 lbs.
	GKC 38/20-GR	10.0	3000	24 HP Gas	UD-12	UD-3	55 lbs.
	GKC 42/15-GR	11.5	2200	22 HP Gas	UD-12	UD-3	49 lbs.
	GKC 50/12-GR	12.5	2000	22 HP Gas	UD-12	UD-3	49 lbs.

# SUPER DUTY - HP GK-Series High Pressure Plunger Pumps

- Heavy Duty Bronze Connecting Rod Assemblies with Guide Pins for Perfect Cap Alignment 2 lbs. each
- Heavy Duty Reinforced Nickel Plated Heads with External and Internal Bracing
- Large Diameter Stainless Steel Valve Caps with Increased Thread Depth
- Reinforcing Ring on Inlet and Discharge Ports
- Deeper Back Covers for Increased Oil Capacity. 40 oz. Crank Case Capacity



GKC 19/40-S

## Solid Shaft Models

24 mm Keyed, Solid Shaft



GKC 17/35-S  
GKC 21/35-S

	MODEL	GPM	PSI	POWER REQUIREMENTS	SEAL KIT	VALVE KIT	WEIGHT
<b>1450 RPM</b>	GKC 17/35-S	4.5	5000	17.0 HP Electric	UD-9	UD-41	42 lbs.
	GKC 19/40-S	5.0	5800	20.0 HP Electric	UD-9	UD-63	43 lbs.
	GKC 21/35-S	5.5	5000	20.0 HP Electric	UD-9	UD-41	42 lbs.
<b>1750 RPM</b>	GKD 5.5/50-S	5.5	5000	20.0 HP Electric	UD-9	UD-41	42 lbs.
<b>Rail Kits</b>	8702.07	Medium ( 1-3/4" ) Rail Kit for GK-Series Solid Shaft Pumps					
	8702.08	Standard ( 1" ) Rail Kit for GK-Series Solid Shaft Pumps					
	8702.25	Tall ( 2-1/2" ) Rail Kit for GK-Series Solid Shaft Pumps					

**U-Pay Freight this Page**



# M-Series High Pressure Plunger Pumps



## Direct Drive, Gas Engine Flange Models

1" Hollow Shaft with Mounting Flange and Set Screw



	MODEL	GPM	PSI	POWER REQUIREMENTS	SEAL KIT	VALVE KIT	WEIGHT
<b>3400 RPM</b>	ML 3.5/30-W	3.5	3000	9 HP Gas	UD-28	UD-2	25 lbs.
	ML 4.0/30-W	4.0	3000	11 HP Gas	UD-28	UD-2	25 lbs.
	ML 5.0/30-W	5.0	3000	14.5 HP Gas	UD-28	UD-2	25 lbs.

When looking at pumps always compare the WEIGHTS of each



## Direct Drive, Gas Engine Flange Models

1" Hollow Shaft with Mounting Flange and Set Screw

	MODEL	GPM	PSI	POWER REQUIREMENTS	SEAL KIT	VALVE KIT	WEIGHT
<b>3400 RPM</b>	ML 3.5/35-W	3.5	3500	11 HP Gas	UD-7	UD-30	27 lbs.
	ML 4.0/35-W	4.0	3500	13 HP Gas	UD-7	UD-30	27 lbs.

When looking at pumps always compare the WEIGHTS of each



## Gear Reduction Drive, Gas Engine Models

1" or 1-1/8" Hollow Shaft (Please Specify)

2.2:1 Gear Reduction

	MODEL	GPM	PSI	POWER REQUIREMENTS	SEAL KIT	VALVE KIT	WEIGHT
<b>Gear Reduction</b>	MC 13/20-GR	3.5	3000	9 HP Gas	UD-28	UD-2	33 lbs.
	MC 15/20-GR	4.0	3000	11 HP Gas	UD-28	UD-2	33 lbs.
	MC 18/20-GR	5.0	3000	14.5 HP Gas	UD-9	UD-2	33 lbs.

When looking at pumps always compare the WEIGHTS of each



## Direct Drive, Electric Flange Models

1-1/8" Hollow Shaft with 182/184 Mounting Flange and Set Screw

	MODEL	GPM	PSI	POWER REQUIREMENTS	SEAL KIT	VALVE KIT	WEIGHT
<b>1750 RPM</b>	MD 4.0/20-U	4.0	2000	5 HP Electric	UD-28	UD-2	26 lbs.
	MD 4.0/30-U	4.0	3000	7.5 HP Electric	UD-28	UD-2	26 lbs.
	MD 5.0/25-U	5.0	2500	7.5 HP Electric	UD-28	UD-2	26 lbs.
	MD 5.0/30-U	5.0	3000	10 HP Electric	UD-28	UD-2	26 lbs.

When looking at pumps always compare the WEIGHTS of each



# Vehicle Cleaning Plunger Pumps

## PDCW-Series Car Wash Pumps



- 24 mm Solid, Keyed Shaft or 5/8" Hollow Shaft
- Brass Manifold
- Stainless Steel Plunger Rods
- Stainless Steel Check Valves
- Solid Ceramic Plungers

	MODEL	GPM	PSI	POWER REQUIREMENTS	INLET	DISCHARGE	WEIGHT
<b>1750 RPM</b>	PDCW 4.0/15-S	4.0	1500	4.0 HP Electric	3/8" FNPT	3/8" FNPT	12 lbs.
	PDCW 4.0/15-Z	4.0	1500	4.0 HP Electric	3/8" FNPT	3/8" FNPT	13 lbs.

When looking at pumps always compare the WEIGHTS of each

## SUPER DUTY MKCW-Series Car Wash Pump



- Dual 20 mm Solid, Keyed Shaft
- Direct, Bolt-in Replacement for '310'
- Includes Rails, Thru-Shaft Protector
- Double Lip Oil Seals
- Brass Manifold
- Bronze Connecting Rods
- Stainless Steel Check Valves
- Custom, Stepped Plunger Rods

	MODEL	GPM	PSI	POWER REQUIREMENTS	INLET	DISCHARGE	WEIGHT
<b>950 RPM</b>	MKCW-3100	4.0	2000	5 HP Electric	1/2" FNPT	3/8" FNPT	32 lbs.

When looking at pumps always compare the WEIGHTS of each

## SUPER DUTY GKCW-Series Car Wash Pumps



- 24 mm Solid, Keyed Shaft
- Bronze Connecting Rods
- Stainless Steel Check Valves
- Solid Ceramic Plungers
- Brass Manifold
- Tapered Roller Bearings
- Stainless Steel Plunger Rods

	MODEL	GPM	PSI	POWER REQUIREMENTS	INLET	DISCHARGE	WEIGHT
<b>1100 RPM</b>	GKCW 18/14-S	5	2000	7.5 HP Electric	3/4" FNPT	3/8" FNPT	39 lbs.
	GKCW 21/14-S	6	2000	10.0 HP Electric	3/4" FNPT	3/8" FNPT	39 lbs.
	GKCW 30/14-S	8	2000	12.5 HP Electric	3/4" FNPT	3/8" FNPT	39 lbs.
	GKCW 38/14-S	10	2000	15.0 HP Electric	3/4" FNPT	1/2" FNPT	39 lbs.

When looking at pumps always compare the WEIGHTS of each

## GSCW-Series Car Wash Pumps



- 35 mm Solid, Keyed Shaft
- Bronze Connecting Rods
- Stainless Steel Check Valves
- Solid Ceramic Plungers
- Brass Manifolds
- Tapered Roller Bearings
- Stainless Steel Plunger Rods

	MODEL	GPM	PSI	POWER REQUIREMENTS	INLET	DISCHARGE	WEIGHT
<b>900 RPM</b>	GSCW 50/NB	12	1500	12.5 HP Electric	1" FNPT	3/4" FNPT	80 lbs.
<b>1200 RPM</b>	GSCW 60/NB	16	1500	15.0 HP Electric	1" FNPT	3/4" FNPT	80 lbs.

When looking at pumps always compare the WEIGHTS of each



# P-Series High Pressure Plunger Pumps

- 7-3/4" L x 8" W x 4" H (Solid Shaft Model)
- Brass Manifold
- Heat Treated Crankshaft
- Stainless Steel Piston Guides
- High Strength Aluminum Alloy or Bronze Connecting Rods
- Industrial Quality Ball Bearings and Needle Bearings
- 12 oz. Capacity Vented Oil Bath Crank Case
- 3/8" Inlet 3/8" Outlet
- Solid Ceramic Plungers
- Stainless Steel Check Valves
- Heavy Duty Flat Base High Pressure Seals
- Max. Fluid Temp. 160°F



## Solid Shaft Models

24 mm Keyed, Solid Shaft

	MODEL	GPM	PSI	POWER REQUIREMENTS	SEAL KIT	VALVE KIT	WEIGHT
<b>1450 RPM</b>	PNC 11/17-S	3.0	2500	5 HP Electric	UD-8	UD-1	12 lbs.
	PNC 13/15-S	3.5	2000	5 HP Electric	UD-8	UD-1	12 lbs.
<b>1750 RPM</b>	PND 3.0/20-S	3.0	2000	4 HP Electric	UD-7	UD-1	12 lbs.
	PND 3.5/20-S	3.5	2000	5 HP Electric	UD-8	UD-1	12 lbs.
	PND 4.0/15-S	4.0	1500	4 HP Electric	UD-8	UD-1	12 lbs.
<b>Rail Kit</b>	8702.10	Standard ( 7/8" ) Rail Kit for P-Series Solid Shaft Pumps					

When looking at pumps always compare the WEIGHTS of each



## Direct Drive, Gas Engine Flange Models

3/4" Hollow Shaft with Mounting Flange and Set Screw

	MODEL	GPM	PSI	POWER REQUIREMENTS	SEAL KIT	VALVE KIT	WEIGHT
<b>3400 RPM</b>	PNL 3.0/20-T	3.0	2000	5.5 HP Gas	UD-7	UD-1	13 lbs.
	PNL 3.0/25-T	3.0	2500	6.5 HP Gas	UD-7	UD-1	14 lbs.
	PNL 3.5/22-T	3.5	2200	6.5 HP Gas	UD-7	UD-1	14 lbs.

When looking at pumps always compare the WEIGHTS of each



## Gear Reduction, Gas Engine Models

3/4" Hollow Shaft  
2.2:1 Gear Reduction

	MODEL	GPM	PSI	POWER REQUIREMENTS	SEAL KIT	VALVE KIT	WEIGHT
<b>Gear Reduction</b>	PNC 11/17-GR	3.0	2500	6.5 HP Gas	UD-8	UD-1	18 lbs.
	PNC 13/15-GR	3.5	2000	6.5 HP Gas	UD-8	UD-1	18 lbs.

When looking at pumps always compare the WEIGHTS of each

**U-Pay Freight this Page**



# PENTA-Series Industrial Plunger Pumps

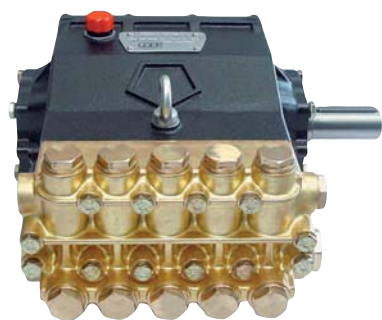

## PENTA-Series Industrial 5-Cylinder Plunger Pumps



- 35 mm Solid Keyed Shaft
- Stainless Steel Check Valves
- Heavy Duty Bronze Connecting Rods with Guide Pins for Perfect Cap Alignment
- Dual Roller Bearings
- Heat Treated Crankshaft
- 80 oz. Crank Case Oil Capacity
- 15"L x 16.5"W x 9"H
- All Penta Pumps Include Lift Ring and Dust Cover to Protect Oil Seals
- Heavy Duty Brass Manifold
- Stainless Steel Plunger Rods
- Solid Ceramic Plungers
- Max. Fluid Temp. 160°F
- Heavy Duty, Flat Base High Pressure Seals
- Replaceable Teflon Coated Body Guides

	MODEL	GPM	PSI	POWER REQUIREMENTS	INLET	DISCHARGE	WEIGHT
<b>5-Cylinder 1000 RPM</b>	PENTA-B 25/400	6.5	6000	25 HP Electric	1" FNPT	1/2" FNPT	110 lbs.
	PENTA-B 30/300	8.0	4500	25 HP Electric	1-1/4" FNPT	3/4" FNPT	110 lbs.
	PENTA-B 40/280	10.0	4000	30 HP Electric	1-1/4" FNPT	3/4" FNPT	110 lbs.
	PENTA-B 50/200	13.0	3000	30 HP Electric	1-1/4" FNPT	3/4" FNPT	110 lbs.
<b>5-Cylinder 1450 RPM</b>	PENTA-C 35/400	9.0	6000	35 HP Electric	1" FNPT	1/2" FNPT	110 lbs.
	PENTA-C 43/300	11.0	4500	35 HP Electric	1-1/4" FNPT	3/4" FNPT	110 lbs.
	PENTA-C 55/280	15.0	4000	40 HP Electric	1-1/4" FNPT	3/4" FNPT	110 lbs.
	PENTA-C 70/200	18.0	3000	40 HP Electric	1-1/4" FNPT	3/4" FNPT	110 lbs.
<b>1750 RPM</b>	PENTA-D 70/280	18.0	4000	50 HP Electric	1-1/4" FNPT	3/4" FNPT	110 lbs.
<b>Rail Kit</b>	8702.30	Tall 2-1/2" Heavy Duty Rail Kit for PENTA Pumps					

When looking at pumps always compare the WEIGHTS of each

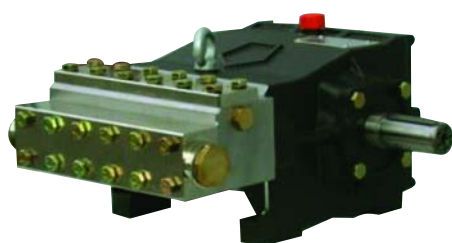

## PENTA-Series Industrial Stainless Head Plunger Pumps

35mm Solid Keyed Shaft

Stainless Steel Block Manifold • Pressurized Inlet Only

	MODEL	GPM	PSI	POWER REQUIREMENTS	INLET	DISCHARGE	WEIGHT
<b>1000 RPM</b>	PENTA-B 20/500	5.0	7300	25 HP Electric	1"	3/8"	135 lbs.
<b>1450 RPM</b>	PENTA-C 27/500	7.0	7300	35 HP Electric	1"	3/8"	135 lbs.
<b>1750 RPM</b>	PENTA-D 33/500	9.0	7300	40 HP Electric	1"	3/8"	135 lbs.
<b>Rail Kit</b>	8702.30	Tall 2-1/2" Heavy Duty Rail Kit for PENTA Pumps					

When looking at pumps always compare the WEIGHTS of each



**BASIC TANK FEED HIGH PRESSURE CLEANING SYSTEM PLUMBING DIAGRAM**

**Up to 7 GPM**

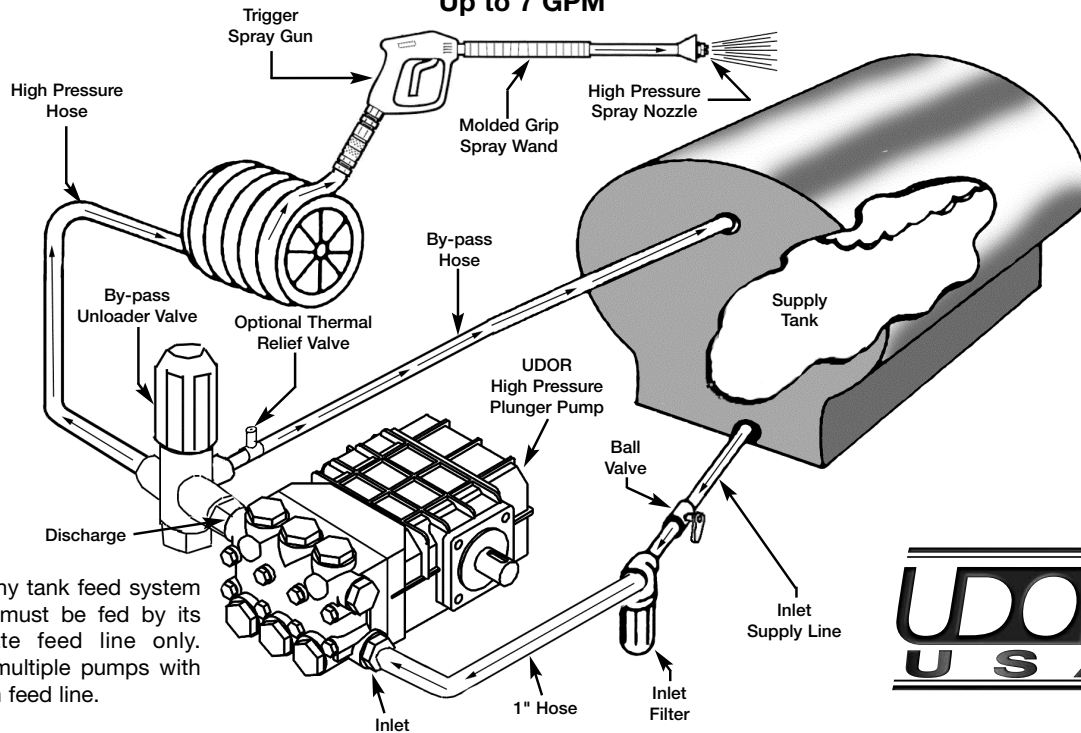

**NOTE:** On any tank feed system each pump must be fed by its own separate feed line only. Never feed multiple pumps with one common feed line.



	Required GPM	Min. Feed Line Size	Inlet Filter (40 Mesh Max.)	
<b>PLUMBING REQUIREMENTS</b>	2 - 4 GPM	3/4"	3/4" 20-40 Mesh Screen	<b>NOTE:</b> All plumbing accessories should be the same or greater diameter as the feed line. All ball valves should be full port valves.
	5 - 7 GPM	1"	1" 20-40 Mesh Screen	
	8 - 15 GPM	1-1/2"	1-1/2" 20-40 Mesh Screen	

**WARNING:** Consult UDOR U.S.A. for plumbing requirements on high speed, 3400 RPM Pumps.

**BASIC TANK FEED HIGH PRESSURE CLEANING SYSTEM PLUMBING DIAGRAM**

**Over 7 GPM. DUAL INLET REQUIRED**

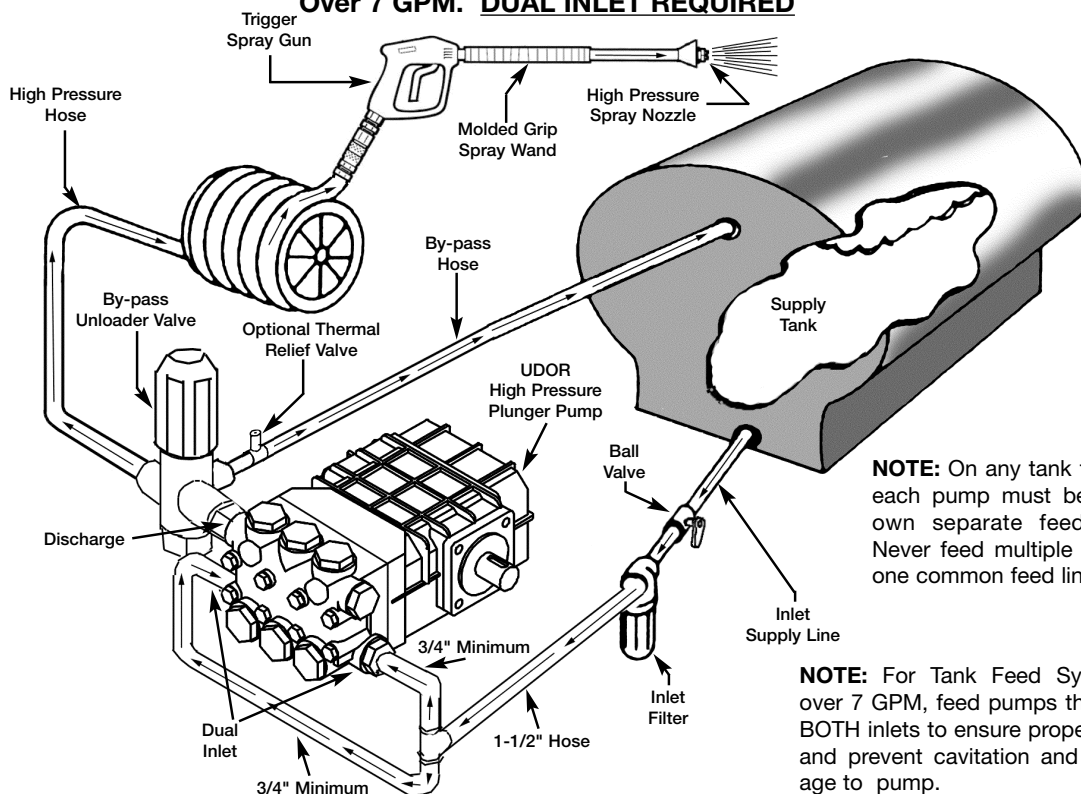

**NOTE:** On any tank feed system each pump must be fed by its own separate feed line only. Never feed multiple pumps with one common feed line.

**NOTE:** For Tank Feed Systems over 7 GPM, feed pumps through BOTH inlets to ensure proper flow and prevent cavitation and damage to pump.

### Diagnosis & Maintenance, UDOR U.S.A. Plunger Pumps

Problem	Probable Cause	Solution
Low Pressure	Worn or Plugged Nozzle	Replace or clean nozzle, of proper size.
	Belt Slippage.	Tighten or replace belt.
	Air leak in inlet plumbing.	Disassemble, reseal and reassemble.
	Pressure gauge inoperative or not registering accurately.	Check with new gauge; replace worn or damaged gauge.
	Relief / unloader valve stuck, partially plugged or improperly adjusted; valve seat worn.	Repair/replace and adjust relief / unloader valve; check for worn and dirty valve seats.
	Inlet suction strainer clogged or improper size.	Clean, use adequate size, check more frequently.
	Worn seals. Abrasives in pumped fluid or severe cavitation. Inadequate water supply.	Install and maintain proper filter. Replace seals. Check inlet water supply. Max. 6 in. inlet vacuum.
	Fouled or dirty inlet or discharge valves.	Clean inlet and discharge valve assemblies.
	Worn inlet or discharge valves.	Replace worn valves.
	Leaky discharge hose.	Replace discharge hose.
Pump runs extremely rough,. pressure very low	Restricted inlet or air entering the inlet plumbing.	Proper size inlet plumbing; check for air tight seal at fittings & filter.
	Inlet restrictions and/or air leaks. Stuck inlet or discharge valves.	Replace worn seals, clean out material in valves or replace worn valves.
	Plugged Inlet Filter	Clean or replace filter.
Water leakage from under the manifold.	Worn inlet seals, Cracked plunger.	Replace seals. Install new plungers.
Oil leak between crankcase and pumping section.	Worn crankcase oil seals.	Replace crankcase oil seals.
Oil leaking in the area of crankshaft.	Worn crankshaft seal, bearing or case o-ring.	Replace crankshaft seal, bearing or case o-ring.
	Bad bearing.	Replace bearing.
Excessive play in the end of the crankshaft	Worn bearing.	Replace ball bearing.
Water in crankcase.	May be caused by humid air condensing into water inside the crankcase.	Change oil at 3 month or 500 hour intervals using UDOR LUBE ( or SAE 30W non-detergent oil).
	Worn or improperly installed inlet water seals.	Replace seals. Follow proper installation procedures. Contact UDOR pump supplier for servicing.
Oil leaking at the rear portion of the crankcase.	Damaged or improperly installed sight glass or crankcase rear cover gasket and drain plug gasket.	Replace sight glass, crankcase cover gasket or drain plug gasket.
Loud knocking noise in pump.	Pulley loose on crankshaft.	Check key and tighten set screw.
	Broken or worn bearing.	Replace bearings.
Frequent or premature failure of the packing	Scored plungers. Over pressure to inlet manifold. Abrasive material in the fluid being pumped. Excessive temperature of fluid being pumped Running pump dry.	Replace plungers Reduce inlet pressure. Max. 75 PSI. Install proper filtration on pump inlet plumbing. Assure fluid inlet temperature are within specified range. Max. 160° F DO NOT run pump without fluid.
Strong surging at the inlet and low pressure discharge.	Foreign particles in the inlet or discharge valve or worn inlet and/or discharge valves.	Replace worn valves. Check supply tank for contamination. Install and regularly clean filter. Never pump abrasive fluids.

REFERENCE



**GENERAL PUMP KITS AND WHAT THEY FIT**

PUMP	Valves	Valve Caps	Packings	Packing w/Brass	Head Rings	Intermediate Ring Kit	Pistons	Piston Bolts	Crankshaft Seal	Oil Seal
<b>CW1012</b>	K62	98231200	K113	K67 (2)	K65	69216770	69040109	K74	K32	K37
<b>CW1541</b>	K943	98242000	K940	K939 (3)	K41	K942	69040009	K74	K32	K32
<b>CW1635</b>	K1094	N/A	F1287	K1095 (3)	N/A	N/A	F124200310	N/A	N/A	N/A
<b>CW2004</b>	K01	K04	K969	K9101A (3)	K07	K71	1310-850	K06	K03	K02
<b>CW24</b>	K01	K04	K969	K9101A (3)	K07	K71	1310-850	K06	K03	K02
<b>CW3040</b>	K01	K04	K969	K9101A (3)	K07	K71--	1310-850	K06	K03	K02
<b>CW61</b>	K943	98242000	K940	K939 (3)	K41	K942	69040009	K74	76021135	K32
<b>CW81</b>	K943	98242000	K940	K939 (3)	K41	K942	69040009	K74	76021035	K32
<b>EZ2536E</b>	K123	K124	K127	K131 (3)	K129	K128	44040109	92221600	N/A	K23
<b>EZ2542E</b>	K123	K124	K127	K131 (3)	K129	K128	44040109	92221600	N/A	K23
<b>EZ2542S</b>	K123	K124	K127	K131 (3)	K129	K128	44040109	92221600	N/A	K23
<b>EZ2545E</b>	K123	K124	K88	K130 (3)	K129	K89	1310-852	92221600	N/A	K23
<b>EZ2545G</b>	K123	K124	K88	K130 (3)	K129	K89	1310-852	92221600	N/A	K23
<b>EZ3035G</b>	K123	K124	K88	K130 (3)	K129	K89	1310-852	92221600	N/A	K23
<b>EZ3040G</b>	K123	K124	K88	K130 (3)	K129	K89	1310-852	92221600	N/A	K23
<b>EZ3040S</b>	K123	K124	K88	K130 (3)	K129	K89	1310-852	92221600	N/A	K23
<b>EZ4040G</b>	K123	K124	K153	K156 (3)	N/A	K154	44040266	92221600	N/A	K23
<b>T1011</b>	K01	K04	K08	K28 (3)	K7	K71	1310-850	K06	K03	K2
<b>T1321</b>	K01	K04	K148	K29 (3)	K11	K149	1310-854	K06	K03	K02
<b>T1511</b>	K01	K04	K08	K28 (3)	K7	K71	1310-850	K06	K03	K02
<b>T1551</b>	K43	96242000	K113	K115 (3)	K65	K66	76040056	K74	K32	K44
<b>T1621</b>	K01	K05	K148	K29 (3)	K11	K149	1310-854	K06	K03	K02
<b>T1631</b>	K01 (2)	K04 (2)	K148 (2)	K29 (6)	K11 (2)	K149 (2)	1310-854	K06 (2)	K24	K02
<b>T2011</b>	K01	K05	K08	K28 (3)	K07	K71	1310-850	K06	K03	K02
<b>T2031</b>	K01 (2)	K04 (2)	K08 (2)	K28 (6)	K07 (2)	K71 (2)	1310-850	K06 (2)	K24	K02 (2)
<b>T41</b>	K62	99366900	K38	K39 (3)	K41	K42	69040009	K74	K32	K37
<b>T4251</b>	K122	99486000	K77	K78 (3)	K07	K75	61040056	61219566	K32	K44
<b>T5050</b>	K150	99428200	K109	K151 (3)	K108	K110	47040856	47219666	K03	K02
<b>T61</b>	K43	98242000	K79	K80 (3)	K48	K81	76040209	K74	K32	K44
<b>T721</b>	K01	K04	K19	K27 (2)	K21	K20	1310-851	K06	N/A	K23
<b>T731</b>	K01	K04	K19	K27 (2)	K21	K20	1310-851	K06	N/A	K23
<b>T81</b>	K43	98242000	K79	K80 (3)	K48	K81	76040209	K74	K32	K44
<b>T9051</b>	K01	K84	K97	K96 (3)	--	--	51040009	--	90164400	K83
<b>T9131</b>	K01	K04	K08	K28 (3)	K7	K71	1310-850	K06	K03	K02
<b>T9161</b>	K01	K05	K08	K28 (3)	K7	K71	1310-850	K06	K03	K02
<b>T921</b>	K01	K04	K148	K29 (3)	K11	K149	1310-854	K06	K03	K02
<b>T9211</b>	K01	K05	K08	K28 (3)	K7	K71	1310-850	K06	K03	K02
<b>T9281</b>	K01	K106	K109	K112 (3)	K108	K110	47040856	K107	K03	K02
<b>T9721</b>	K01	K04	K19	K27 (3)	K21	K20	1310-851	K06	N/A	K23
<b>T9731</b>	K01	K04	K19	K27 (3)	K21	K20	1310-851	K06	N/A	K23
<b>T9791</b>	K01	K04	K19	K27 (3)	K21	K20	1310-851	K06	N/A	K23
<b>T991</b>	K01	K04	K19	K27 (3)	K21	K20	1310-851	K06	N/A	K23
<b>T9951</b>	K01	K04	K19	K27 (3)	K21	K20	1310-851	K06	N/A	K23

## GENERAL PUMP KITS AND WHAT THEY FIT

PUMP	Valves	Valve Caps	Packings	Packing w/Brass	Head Rings	Intermediate Ring Kit	Pistons	Piston Bolts	Crankshaft Seal	Oil Seal
<b>T9971</b>	K01	K04	K19	K27 (3)	K21	K20	1310-851	K06	90164400	K23
<b>TS1011</b>	K01	K04	K08	K28 (3)	K07	K71	1310-850	K06	K03	K02
<b>TS1021</b>	K01	K04	K08	K28 (3)	K07	K71	1310-850	K06	K03	K02
<b>TS1041</b>	K62	--	K08	K82 (3)	K07	K71	1310-850	K54	K03	K37
<b>TS1321</b>	K01	K04	K12	K29 (3)	K11	K149	1310-854	K06	K03	K02
<b>TS1331</b>	K01	K04	K08	K28 (3)	K07	K71	1310-850	K06	K03	K02
<b>TS1511</b>	K01	K04	K08	K28 (3)	K07	K71	1310-850	K06	K03	K02
<b>TS1531</b>	K62	98231200	K08	K82 (3)	K07	K71	1310-850	K54	K32	K37
<b>TS1621</b>	K01	K05	K12	K29 (3)	K29	K1497	1310-854	K06	K03	K02
<b>TS1711</b>	K01	K04	K08	K28 (3)	K07	K71	1310-850	K06	K03	K02
<b>TS2011</b>	K01	K05	K08	K28 (3)	K07	K71	1310-850	K06	K03	K02
<b>TS2021</b>	K01	K05	K08	K28 (3)	K07	K71	1310-850	K06	K03	K02
<b>TS821</b>	K01	K04	K08	K28 (3)	K07	K71	1310-850	K06	K03	K02
<b>TS921</b>	K01	K04	K148	K29 (3)	K11	K149	1310-854	K06	K03	K02
<b>TSF2019</b>	K169	66130041	K170	K171 (3)	--	66216070	66040009	99380100	K03	K02
<b>TSF2021</b>	K169	66130041	K170	K171 (3)	--	66216070	66040009	99380100	K03	K02
<b>TSF2219</b>	K169	66130041	K172	K173 (3)	--	66216070	66040109	99380100	K03	K02
<b>TSF2221</b>	K169	66130041	K172	K173 (3)	--	66216070	66040109	99380100	K03	K02
<b>TSF2421</b>	K169	66130041	K181	K182 (3)	--	66216070	66040409	99380100	K03	K02
<b>TSP1621</b>	K150	66130041	K174	K175 (3)	--	66216070	66040209	99380100	K03	K02
<b>TSP1819</b>	K150	66130041	K180	K176 (3)	--	66216070	66040309	99380100	K03	K02
<b>TSP1821</b>	K150	66130041	K180	K176 (3)		66216070	66040309	99380100	K03	K02
<b>TT2028E</b>	K01	K84	K97	K96 (3)	51100051	--	51040009	--	--	K83
<b>TT2028G</b>	K01	K84	K97	K96 (3)	--	--	51040009	--	--	K83
<b>TT2035</b>	K01	K84	K97	K96 (3)	--	--	51040009	--	--	K83
<b>TT9061</b>	K01	K84	K97	K96 (3)	--	--	51040009	--	--	K83
<b>TT9071</b>	K01	K84	K97	K96 (3)	--	--	51040009	--	--	K83
<b>TT9111</b>	K01	K84	K141	K140 (3)	--	--	51040109	--	--	K83
<b>TT9351</b>	K01	K04	K88	K92 (3)	K90	K89	1310-852	--	--	K23
<b>TT941</b>	K01	K84	K97	K96 (3)	--	--	51040009	--	--	K83
<b>TT9441</b>	K01	K04	K88	K92 (3)	K90	K89	1310-852	--	--	K23
<b>TX1505G6</b>	K123	K124	K160	K166 (3)	--	K164	1310-852	--	--	K159
<b>TX1506G6</b>	K123	K124	K160	K166 (3)	--	K164	1310-852	--	--	K159
<b>TX1508G6</b>	K123	K124	K160	K166 (3)	--	K164	1310-852	--	--	K159
<b>TX1508G8</b>	K123	K124	K160	K166 (3)	--	K164	1310-852	--	--	K159
<b>TX1509G8</b>	K123	K124	K160	K166 (3)	--	K164	1310-852	--	--	K159
<b>TX1510G8</b>	K123	K124	K160	K166 (3)	--	K164	1310-852	--	--	K159



# UDOR - the industry's TOUGHEST PUMP!

Remember...

Heavier Pumps work harder and last longer. When purchasing a pump always look at the weight of the pump as well.



## GC2120E

**Model:** GC2120E  
**PSI:** 3500  
**GPM:** 5.5  
**RPM:** 1450  
**PRICE:** \$496.60  
**Weight** 36 lbs.



Same 'foot print' as the General, A-R & Comet.  
 Painless replacement for the industry's toughest pump!

This pump will last twice as long!

How good is this pump? We have been selling and manufacturing with the Udor Pump for over 10 years and have experienced...  
 ...'0' failures!



**Model:** MLK4040W  
**PSI:** 4000  
**GPM:** 4.0  
**RPM:** 3400  
**PRICE:** \$362.,80  
**Weight** 28 lbs.

UDOR #	Shaft	RPM	Drive	GPM	PSI	Weight	PRICE
MC 1820-S	24MM	1450	Pulley	5.0	3000	23 lbs.	\$333.40
MKC 1824-S	24MM	1450	Pulley	5.0	3500	27 lbs.	\$381.70
MKC 2024-S	24MM	1450	Pulley	5.5	3500	27 lbs.	\$394.30
MKL 4040W	----	3400	Direct	4.0	4000	28 lbs.	\$362.80
MKL 5035W	----	3400	Direct	5.0	3500	28 lbs.	\$381.70
GKC 3024-S	24MM	1450	Pulley	8.0	3500	40 lbs.	\$637.90
GKC 3820-S	24MM	1450	Pulley	10.0	3000	40 lbs.	\$656.80
GKC 4215-S	24MM	1450	Pulley	11.5	2200	39 lbs.	\$656.80
GKC 5012-S	24MM	1450	Pulley	12.5	2000	39 lbs.	\$682.00
GKC 1735-S	24MM	1450	Pulley	4.5	5000	42 lbs.	\$789.10
GKC 1940-S	24MM	1450	Pulley	5.0	5800	43 lbs.	\$980.20
GKC 2135-S	24MM	1450	Pulley	5.5	5000	42 lbs.	\$797.50

see the weight ↓

## TS2021

**Model:** TS2021  
**PSI:** 3500  
**GPM:** 5.6  
**RPM:** 1450  
**PRICE:** \$485.13  
**Weight** 32 lbs.



## EZ4040G

**Model:** EZ4040G  
**PSI:** 4000  
**GPM:** 4.0  
**RPM:** 3400  
**PRICE:** \$298.70  
**Weight** 20 lbs.



**U-Pay Freight this Page**



**ALL OF GENERAL PUMP PRICING**

CW1012	1439.95	T1321D	464.98	TC1507E346	276.69	TS1621	524.18	TT9071EBFUUL	292.86
CW1012L	1439.95	T1321L	447.50	TC1507G	271.33	TS1621L	524.18	TT9071GB	250.49
CW1522	3876.46	T151	3783.30	TC1507GUI	305.29	TS1711	447.50	TT9071GBF	250.49
CW1541	4352.28	T1551	3049.28	TC1507GUIL	305.29	TS1711L	447.50	TT9071GBFL	250.49
CW2004	543.09	T1591	4746.43	TC1507S34	257.99	TS1811	454.39	TT9071GBFU	288.04
CW2004L	570.14	T1621	524.18	TC1508E175	271.33	TS2011	524.18	TT9071GBFUI	292.86
CW2040	564.55	T1621L	524.18	TC1508E346	276.69	TS2011L	524.18	TT9071GBFUUL	292.86
CW24	535.15	T1631	1470.55	TC1508G	271.33	TS2021	485.13	TT9071GFL	246.96
CW24L	535.15	T2031	1470.55	TC1508GUI	305.29	TS2021L	487.81	TT9071GFUUL	288.73
CW3040	555.05	T3551	5731.89	TC1508GUIL	305.29	TS921	510.13	TT9111	260.24
CW3040L	555.05	T41	824.33	TC1508S34	267.95	TSF1819	706.58	TT9111EBF	276.91
CW61	2517.24	T41L	824.33	TC1509E175	271.33	TSF2019	604.00	TT9111EBFL	276.91
CW61L	2517.24	T4251	3714.43	TC1509E175L	271.33	TSF2019DS	744.75	TT9111L	260.24
CW81	2517.24	T4251L	3714.43	TC1509E175UI	305.29	TSF2019L	629.00	TT931	235.15
CW81L	2517.24	T5050	1017.50	TC1509E17N	271.33	TSF2021	604.00	TT9351	375.11
EZ2530SUI	368.88	T5050L	1017.50	TC1509G	271.33	TSF2021L	629.00	TT9351L	375.11
EZ2536E	348.65	T61	2351.58	TC1509GUI	305.29	TSF2219	687.73	TT941	235.15
EZ2536EL	348.65	T61L	2402.46	TC1509GUIL	305.29	TSF2219L	712.73	TT9441	375.11
EZ2536EUI	395.34	T711	332.70	TC1509S17	257.99	TSF2221	719.75	TT9441L	375.11
EZ2536S	333.31	T721B	268.54	TC1511S17	257.99	TSF2221L	729.75	TT951	235.15
EZ2536SL	333.31	T721BL	279.05	TC1511S17L	257.99	TSF2421	838.52	TX1505G6	288.73
EZ2542E	348.65	T731B	268.54	TC1802E175	271.33	TSF2421L	863.52	TX1506G6	288.73
EZ2542EL	348.65	T731BL	279.05	TC1802E175L	271.33	TSF2819	1085.20	TX1506G6UUL	321.96
EZ2542S	333.31	T81	2351.58	TC1809E175	271.33	TSP1621	786.60	TX1506G6UUK	335.20
EZ2542SL	333.31	T81L	2351.58	TC1809E175L	271.33	TSP1621L	836.60	TX1506G8	295.73
EZ2545E	348.65	T8271	1302.03	TC1809E17N	271.33	TSP1819	786.60	TX1506G8UI	321.96
EZ2545EL	348.65	T9051EB	252.48	TC1809HA17	295.80	TSP1819L	836.60	TX1506G8UK	335.20
EZ2545S	333.31	T9051EBF	263.03	TC1809S17	257.99	TSP1821	786.88	TX1506S34	274.81
EZ2545SL	333.31	T9051EBFL	263.03	TC1809S17L	257.99	TSP1821L	836.88	TX1508G6	288.73
EZ2555E	348.65	T9051EBFU	288.04	TC1811S17	257.99	TT1540GBF	258.16	TX1508G8	295.73
EZ2555EL	348.65	T9051EBFUI	292.86	TP2021C17	271.33	TT2021EBF	265.85	TX1508G8UI	321.96
EZ2555S	348.65	T9051EBFUUL	292.86	TP2021S17	255.30	TT2021EBFL	258.16	TX1508G8UIA	321.96
EZ3030G34	333.31	T911	327.11	TP2024C17	271.33	TT2028EBF	258.16	TX1508G8UUL	321.96
EZ3030G34U	379.10	T9161L	549.23	TP2032C17	271.33	TT2028EBFL	258.16	TX1508G8UK	335.20
EZ3030G34UL	379.10	T921	434.93	TP2032S17	255.30	TT2028GBF	258.16	TX1508S34	274.81
EZ3035G	366.78	T9211	549.23	TP2520J34	260.31	TT2028GBFL	258.16	TX1509G8	295.73
EZ3035GL	366.78	T9211L	549.23	TP2520J34UI	296.85	TT2028GBFUI	299.20	TX1509G8UI	321.96
EZ3035GUI	407.85	T921L	434.93	TP2520J34UUL	296.85	TT2028GBFUUL	299.20	TX1509G8UUL	321.96
EZ3035GUIL	407.85	T9281	767.14	TP2526J34	260.31	TT2028X34	261.58	TX1509G8UK	335.20
EZ3035GUKL	428.04	T9711EBF	299.10	TP2526J34UFL	296.85	TT2035EBF	258.16	TX1509G8UUK	335.20
EZ3040G	366.78	T9721B	268.54	TP2526J34UI	296.85	TT2035EBFL	258.16	TX1510E349	288.73
EZ3040GFUI	407.85	T9721BL	279.05	TP2526J34UUL	296.85	TT2035EBFUI	299.20	TX1510G8	295.73
EZ3040GL	366.78	T9721EBF	299.10	TP2530J34	279.33	TT2035GBF	258.16	TX1510G8L	295.73
EZ3040GUI	407.85	T9721EBFL	297.10	TP2530J34L	248.38	TT2035GBFL	258.16	TX1510G8UIA	321.96
EZ3040GUIL	407.85	T9731B	268.54	TP2530J34UI	283.18	TT2035GBFU	292.24	TX1510G8UUL	321.96
EZ3040GUKL	428.04	T9731BL	279.05	TP2530J34UUL	283.18	TT2035GBFUUL	299.20	TX1510G8UK	335.20
EZ3040S	348.65	T9731EBF	299.10	TP2530X34	255.30	TT2035GBFUUL	299.20	TX1510G8UUKL	335.20
EZ3040SL	348.65	T9731EBFL	297.10	TP2530X34L	255.30	TT901	235.15	TX1510S34	274.81
EZ3042S	361.88	T9791B	279.05	TP2530X34UUL	283.18	TT9061EBF	280.62	TX1510S34L	274.81
EZ3042SL	361.88	T991	340.35	TP2533J34	260.31	TT9061EBFL	250.49	TX1510S34UIA	301.09
EZ3045G	366.78	T991L	340.35	TP2533J34UUL	296.85	TT9061EBFU	288.04	TX1512E179	288.73
EZ3045GL	366.78	T9951	340.35	TS1011	434.93	TT9061EBFUUL	292.86	TX1512S17	274.81
EZ3045GUI	407.85	T9951L	340.35	TS1011L	434.93	TT9061EBFUUL	292.86	TX1512S17L	274.81
EZ4030G34	407.85	T9971	433.65	TS1021	447.50	TT9061EBFXI	235.15	TX1513S17	287.35
EZ4030S34	388.34	T9971L	433.65	TS1021L	447.50	TT9061EFL	246.96	TX1513S17L	287.35
EZ4035E34	407.85	TC1502E175	271.33	TS1041	924.59	TT9061EFUI	288.73	TX1810E179	288.73
EZ4035G34L	407.85	TC1502E175L	271.33	TS1041L	924.59	TT9061GBF	250.49	TX1810E179L	288.73
EZ4035S34	388.34	TC1504E345L	305.29	TS1321	447.50	TT9061GBFL	250.49	TX1810HA17	317.04
EZ4040E34	407.85	TC1505E345	271.33	TS1321L	447.50	TT9061GBFU	288.04	TX1810S17	274.81
EZ4040E34L	407.85	TC1505E345L	271.33	TS1331	434.93	TT9061GBFUUL	292.86	TX1810S17L	274.81
EZ4040G	298.70	TC1506E345	271.33	TS1331L	434.93	TT9061GBFUUL	292.86	TX1812E179	288.73
EZ4040GL	407.85	TC1506E346	276.69	TS1511	384.17	TT9061GFUL	283.90	TX1812E179L	288.73
EZ4040S34	407.85	TC1506G	271.33	TS1511H	592.83	TT9071CSOV	292.86	TX1812E179UI	321.96
T1011	434.93	TC1506GUI	305.29	TS1511L	409.17	TT9071EBF	280.62	TX1812S17	274.81
T1011L	434.93	TC1506GUIL	305.29	TS1521	549.23	TT9071EBFL	250.49	TX1812S17L	274.81
T121	3783.30	TC1507E345	271.33	TS1531	1190.63	TT9071EBFU	288.04	TX1813S17	287.35
T1321	447.50	TC1507E345L	271.33	TS1531L	1190.63	TT9071EBFUUL	292.86	TX1813S17L	287.35

**OUR PUMPS  
COME DIRECT FROM  
THE MANUFACTURER  
AND NOT A  
'BACKDOOR' RESELLER  
IN THE PAST WE HAVE USED A  
THIRD PARTY RESELLER BUT HAD  
WARRANTY ISSUES. NOW WE  
SHIP ONLY FROM MANUFACTURES**



**POPULAR  
GENERAL PUMPS**

Model	PSI	GPM	RPM	PRICE
TSF2019	3600	6.3	1450	\$604.00
TSF2019L	3600	6.3	1450	\$629.00
TSF2021	3600	7.0	1450	\$604.00
TSF2021L	3600	7.0	1450	\$629.00
TSF2219	3000	7.0	1450	\$687.73
TSF2219L	3000	7.0	1450	\$712.73
TSF2221	3000	8.5	1450	\$719.75
TSF2221L*	3000	8.5	1450	\$729.75
TSF2421	2500	12.0	1450	\$838.52
TSF2421L*	2500	12.0	1450	\$863.52

NOTE: "L" = Left Hand Shaft

**CALL FOR COMET & CAT**





**GENERAL HIGH PRESSURE JETTING PUMPS**

**KE SERIES**



**KF SERIES**



**LHZ SERIES**



**MK SERIES**



F201030080	9,577.52	KS28SA15R2	10,174.92	MK40A18R3	17,539.42	MKS50A15R4	19,112.46	MSN5015R3	38,444.99
F250201000	3,406.68	KS28SA15R3	10,174.92	MK40A18R4	17,539.42	MKS50A15R5	19,112.46	MSN5015R4	38,444.99
F250220020L	10,550.87	KS28SA15R4	10,174.92	MK40A18R5	17,539.42	MKS50A18HR3	19,422.03	MSN5015R5	38,444.99
F250220020R	10,550.87	KS28SA15R5	10,174.92	MK45A15R1	17,539.42	MKS50A18R1	19,112.46	MSN5018R1	38,444.99
F250220080	10,114.27	KS28SA18R1	10,174.92	MK45A15R2	17,539.42	MKS50A18R2	19,112.46	MSN5018R2	38,444.99
F250222030	10,114.27	KS28SA18R2	10,174.92	MK45A15R3	17,539.42	MKS50A18R3	19,112.46	MSN5018R3	38,444.99
F250222340	9,951.18	KS28SA18R3	10,174.92	MK45A15R4	17,539.42	MKS50A18R4	19,112.46	MSN5018R4	38,444.99
F250222340R	9,951.18	KS28SA18R4	10,174.92	MK45A15R5	17,539.42	MKS50A18R5	19,112.46	MSN5018R5	38,444.99
F70602001	2,702.27	KS28SA18R5	10,174.92	MK45A18R1	17,539.42	MKS55A15R1	19,112.46	MSN55	37,704.53
FPKF000	3,193.81	KS28SA	9,538.04	MK45A18R2	17,539.42	MKS55A15R2	19,112.46	MSN5515R1	38,444.99
FPKFS000	3,193.81	KS32A	9,538.04	MK45A18R3	17,539.42	MKS55A15R3	19,112.46	MSN5515R2	38,444.99
FPMS8450	8,915.46	KS32A15R1	10,174.92	MK45A18R4	17,539.42	MKS55A15R4	19,112.46	MSN5515R3	38,444.99
HF18A	5,618.89	KS32A15R2	10,174.92	MK45A18R5	17,539.42	MKS55A15R5	19,112.46	MSN5515R4	38,444.99
HF18AL	5,618.89	KS32A15R3	10,174.92	MK50A15R1	17,539.42	MKS55A18HR3	19,422.03	MSN5515R5	38,444.99
HF20A	5,618.89	KS32A15R4	10,174.92	MK50A15R2	17,539.42	MKS55A18HR5	19,422.03	MSN5518R1	38,444.99
HF22A	5,618.89	KS32A15R5	10,174.92	MK50A15R3	17,539.42	MKS55A18L1	19,112.46	MSN5518R2	38,444.99
HF22AL	5,618.89	KS32A18L3	10,174.92	MK50A15R4	17,539.42	MKS55A18R1	19,112.46	MSN5518R3	38,444.99
HF25A	5,618.89	KS32A18L4	10,174.92	MK50A15R5	17,539.42	MKS55A18R2	19,112.46	MSN5518R4	38,444.99
HF25AL	5,618.89	KS32A18R1	10,174.92	MK50A18R1	17,539.42	MKS55A18R3	19,112.46	MSN5518R5	38,444.99
HFN25A	12,021.48	KS32A18R2	10,174.92	MK50A18R2	17,539.42	MKS55A18R4	19,112.46	MW32A15L1	12,793.98
KE20A	3,498.23	KS32A18R3	10,174.92	MK50A18R3	17,539.42	MKS55A18R5	19,112.46	MW32A15L2	12,793.98
KE20AL	3,498.23	KS32A18R4	10,174.92	MK50A18R4	17,539.42	MKS60A15R1	19,112.46	MW32A15L3	12,793.98
KE22A	3,498.23	KS32A18R5	10,174.92	MK50A18R5	17,539.42	MKS60A15R2	19,112.46	MW32A15L4	12,793.98
KE22AL	3,498.23	KS32A22R1	10,174.92	MK55A15R1	17,539.42	MKS60A15R3	19,112.46	MW32A15L5	12,793.98
KE24A	3,498.23	KS32A22R2	10,174.92	MK55A15R2	17,539.42	MKS60A15R4	19,112.46	MW32A15R1	12,793.98
KE24AL	3,498.23	KS32A22R3	10,174.92	MK55A15R3	17,539.42	MKS60A15R5	19,112.46	MW32A15R2	12,793.98
KE28A	3,498.23	KS32A22R4	10,174.92	MK55A15R4	17,539.42	MKS60A18HR3	19,422.03	MW32A15R3	12,793.98
KE28AL	3,498.23	KS32A22R5	10,174.92	MK55A15R5	17,539.42	MKS60A18R1	19,112.46	MW32A15R4	12,793.98
KE30A	3,498.23	KS36A	9,538.04	MK55A18R1	17,539.42	MKS60A18R2	19,112.46	MW32A15R5	12,793.98
KE30AL	3,498.23	KS36A15R1	10,174.92	MK55A18R2	17,539.42	MKS60A18R3	19,112.46	MW32A18HDL1	13,048.62
KE36MA	4,155.72	KS36A15R2	10,174.92	MK55A18R3	17,539.42	MKS60A18R4	19,112.46	MW32A18HDL2	13,048.62
KEN20A	4,228.39	KS36A15R3	10,174.92	MK55A18R4	17,539.42	MKS60A18R5	19,112.46	MW32A18HDL3	13,048.62
KEN20AL	4,228.39	KS36A15R4	10,174.92	MK55A18R5	17,539.42	MKS65A15R1	19,112.46	MW32A18HDL4	13,048.62
KEN24A	4,228.39	KS36A15R5	10,174.92	MK60A15L5	17,539.42	MKS65A15R2	19,112.46	MW32A18HDL5	13,048.62
KEN28A	4,228.39	KS36A18R1	10,174.92	MK60A15R1	17,539.42	MKS65A15R3	19,112.46	MW32A18L1	12,793.98
KEN30A	4,228.39	KS36A18R2	10,174.92	MK60A15R2	17,539.42	MKS65A15R4	19,112.46	MW32A18L2	12,793.98
KEZ20A	5,244.66	KS36A18R3	10,174.92	MK60A15R3	17,539.42	MKS65A15R5	19,112.46	MW32A18L3	12,793.98
KEZ22A	5,244.66	KS36A18R4	10,174.92	MK60A15R4	17,539.42	MKS65A18HR3	19,422.03	MW32A18L4	12,793.98
KEZ24A	5,244.66	KS36A18R5	10,174.92	MK60A15R5	17,539.42	MKS65A18R1	19,112.46	MW32A18L5	12,793.98
KEZ28A	5,244.66	KS36A22R1	10,174.92	MK60A18L5	17,539.42	MKS65A18R2	19,112.46	MW32A18R1	12,793.98
KEZ30A	5,244.66	KS36A22R2	10,174.92	MK60A18R1	17,539.42	MKS65A18R3	19,112.46	MW32A18R2	12,793.98
KEZ36A	5,244.66	KS36A22R3	10,174.92	MK60A18R2	17,539.42	MKS65A18R4	19,112.46	MW32A18R3	12,793.98
KEZ36AL	5,244.66	KS36A22R4	10,174.92	MK60A18R3	17,539.42	MKS65A18R5	19,112.46	MW32A18R4	12,793.98
KF28A	4,817.78	KS36A22R5	10,174.92	MK60A18R4	17,539.42	MSN36	37,704.53	MW32A18R5	12,793.98
KF28AL	4,817.78	KS40A	9,538.04	MK60A18R5	17,539.42	MSN3615R1	38,444.99	MW32A22L1	12,793.98
KF30A	4,817.78	KS40A15R1	10,174.92	MK65A15R1	17,539.42	MSN3615R2	38,444.99	MW32A22L2	12,793.98
KF30AL	4,817.78	KS40A15R2	10,174.92	MK65A15R2	17,539.42	MSN3615R3	38,444.99	MW32A22L3	12,793.98
KF36A	4,817.78	KS40A15R3	10,174.92	MK65A15R3	17,539.42	MSN3615R4	38,444.99	MW32A22L4	12,793.98
KF36AL	4,817.78	KS40A15R4	10,174.92	MK65A15R4	17,539.42	MSN3615R5	38,444.99	MW32A22L5	12,793.98
KF40A	4,817.78	KS40A15R5	10,174.92	MK65A15R5	17,539.42	MSN3618R1	38,444.99	MW32A22R1	12,793.98
KF40AL	4,817.78	KS40A18R1	10,174.92	MK65A18R1	17,539.42	MSN3618R2	38,444.99	MW32A22R2	12,793.98
KF40MBA	5,944.48	KS40A18R2	10,174.92	MK65A18R2	17,539.42	MSN3618R3	38,444.99	MW32A22R3	12,793.98
KFM40A	5,875.24	KS40A18R3	10,174.92	MK65A18R3	17,539.42	MSN3618R4	38,444.99	MW32A22R4	12,793.98
KFN28A	5,673.82	KS40A18R4	10,174.92	MK65A18R4	17,539.42	MSN3618R5	38,444.99	MW32A22R5	12,793.98
KFN30A	5,673.82	KS40A18R5	10,174.92	MK65A18R5	17,539.42	MSN40	37,704.53	MW36A15L1	12,793.98
KFN36A	5,673.82	KS40A22R1	10,174.92	MKS40A15R1	19,112.46	MSN4015L5	38,444.99	MW36A15L2	12,793.98
KFZ28A	7,761.86	KS40A22R2	10,174.92	MKS40A15R2	19,112.46	MSN4015R1	38,444.99	MW36A15L3	12,793.98
KFZ30A	7,761.86	KS40A22R3	10,174.92	MKS40A15R3	19,112.46	MSN4015R2	38,444.99	MW36A15L4	12,793.98
KFZ36A	7,761.86	KS40A22R4	10,174.92	MKS40A15R4	19,112.46	MSN4015R3	38,444.99	MW36A15L5	12,793.98
KFZ40A	7,761.86	KS40A22R5	10,174.92	MKS40A15R5	19,112.46	MSN4015R4	38,444.99	MW36A15R1	12,793.98
KFZ40AL	7,761.86	LK3615	23,495.68	MKS40A18HR3	19,422.03	MSN4015R5	38,444.99	MW36A15R2	12,793.98
KS28A	9,538.04	LK3617	23,495.68	MKS40A18R1	19,112.46	MSN4018R1	38,444.99	MW36A15R3	12,793.98
KS28A15R1	10,174.92	LK4015	23,495.68	MKS40A18R2	19,112.46	MSN4018R2	38,444.99	MW36A15R4	12,793.98
KS28A15R2	10,174.92	LK4017	23,495.68	MKS40A18R3	19,112.46	MSN4018R3	38,444.99	MW36A15R5	12,793.98
KS28A15R3	10,174.92	LK4515	23,495.68	MKS40A18R4	19,112.46	MSN4018R4	38,444.99	MW36A18HDL1	13,048.62
KS28A15R4	10,174.92	LK4517	23,495.68	MKS40A18R5	19,112.46	MSN4018R5	38,444.99	MW36A18HDL2	13,048.62
KS28A15R5	10,174.92	LK5015	23,495.68	MKS45A15R1	19,112.46	MSN45	37,704.53	MW36A18HDL3	13,048.62
KS28A18R1	10,174.92	LK5017	23,495.68	MKS45A15R2	19,112.46	MSN4515R1	38,444.99	MW36A18HDL4	13,048.62
KS28A18R2	10,174.92	LK5515	23,495.68	MKS45A15R3	19,112.46	MSN4515R2	38,444.99	MW36A18HDL5	13,048.62
KS28A18R3	10,174.92	LK5517	23,495.68	MKS45A15R4	19,112.46	MSN4515R3	38,444.99	MW36A18L1	12,793.98
KS28A18R4	10,174.92	LK6015	23,495.68	MKS45A15R5	19,112.46	MSN4515R4	38,444.99	MW36A18L2	12,793.98
KS28A18R5	10,174.92	LK6017	23,495.68	MKS45A18HR3	19,422.03	MSN4515R5	38,444.99	MW36A18L3	12,793.98
KS28A22R1	10,174.92	MK40A15L5	17,539.42	MKS45A18R1	19,112.46	MSN4518R1	38,444.99	MW36A18L4	12,793.98
KS28A22R2	10,174.92	MK40A15R1	17,539.42	MKS45A18R2	19,112.46	MSN4518R2	38,444.99	MW36A18L5	12,793.98
KS28A22R3	10,174.92	MK40A15R2	17,539.42	MKS45A18R3	19,112.46	MSN4518R3	38,444.99	MW36A18R1	12,793.98
KS28A22R4	10,174.92	MK40A15R3	17,539.42	MKS45A18R4	19,112.46	MSN4518R4	38,444.99	MW36A18R2	12,793.98
KS28A22R5	10,174.92	MK40A15R4	17,539.42	MKS45A18R5	19,112.46	MSN4518R5	38,444.99	MW36A18R3	12,793.98
KS28AL	9,538.04	MK40A15R5	17,539.42	MKS50A15R1	19,112.46	MSN50	37,704.53	MW36A18R4	12,793.98
KS28SA	9,538.04	MK40A18R1	17,539.42	MKS50A15R2	19,112.46	MSN5015R1	38,444.99	MW36A18R5	12,793.98
KS28SA15R1	10,174.92	MK40A18R2	17,539.42	MKS50A15R3	19,112.46	MSN5015R2	38,444.99	MW36A22L1	12,793.98



# GENERAL HIGH PRESSURE JETTING PUMPS

For Specification  
visit our web site  
[www.envirospec.com](http://www.envirospec.com)

MW36A22L2	12,793.98	MW50A15L2	12,793.98	MWR32A18HDL1	13,277.51	MWR40A18R1	13,022.87	MWR50A22L5	13,022.87
MW36A22L3	12,793.98	MW50A15L3	12,793.98	MWR32A18HDL2	13,277.51	MWR40A18R2	13,022.87	MWR50A22R1	13,022.87
MW36A22L4	12,793.98	MW50A15L4	12,793.98	MWR32A18HDL3	13,277.51	MWR40A18R3	13,022.87	MWR50A22R2	13,022.87
MW36A22L5	12,793.98	MW50A15L5	12,793.98	MWR32A18HDL4	13,277.51	MWR40A18R4	13,022.87	MWR50A22R3	13,022.87
MW36A22R1	12,793.98	MW50A15R1	12,793.98	MWR32A18HDL5	13,277.51	MWR40A18R5	13,022.87	MWR50A22R4	13,022.87
MW36A22R2	12,793.98	MW50A15R2	12,793.98	MWR32A18L1	13,022.87	MWR40A22L1	13,022.87	MWR50A22R5	13,022.87
MW36A22R3	12,793.98	MW50A15R3	12,793.98	MWR32A18L2	13,022.87	MWR40A22L2	13,022.87	MWR55A15L1	13,022.87
MW36A22R4	12,793.98	MW50A15R4	12,793.98	MWR32A18L3	13,022.87	MWR40A22L3	13,022.87	MWR55A15L2	13,022.87
MW36A22R5	12,793.98	MW50A15R5	12,793.98	MWR32A18L4	13,022.87	MWR40A22L4	13,022.87	MWR55A15L3	13,022.87
MW40A15L1	12,793.98	MW50A18HDL1	13,048.62	MWR32A18L5	13,022.87	MWR40A22L5	13,022.87	MWR55A15L4	13,022.87
MW40A15L2	12,793.98	MW50A18HDL2	13,048.62	MWR32A18R1	13,022.87	MWR40A22R1	13,022.87	MWR55A15L5	13,022.87
MW40A15L3	12,793.98	MW50A18HDL3	13,048.62	MWR32A18R2	13,022.87	MWR40A22R2	13,022.87	MWR55A15R1	13,022.87
MW40A15L4	12,793.98	MW50A18HDL4	13,048.62	MWR32A18R3	13,022.87	MWR40A22R3	13,022.87	MWR55A15R2	13,022.87
MW40A15L5	12,793.98	MW50A18HDL5	13,048.62	MWR32A18R4	13,022.87	MWR40A22R4	13,022.87	MWR55A15R3	13,022.87
MW40A15R1	12,793.98	MW50A18L1	12,793.98	MWR32A18R5	13,022.87	MWR40A22R5	13,022.87	MWR55A15R4	13,022.87
MW40A15R2	12,793.98	MW50A18L2	12,793.98	MWR32A22L1	13,022.87	MWR45A15L1	13,022.87	MWR55A15R5	13,022.87
MW40A15R3	12,793.98	MW50A18L3	12,793.98	MWR32A22L2	13,022.87	MWR45A15L2	13,022.87	MWR55A18HDL1	13,277.51
MW40A15R4	12,793.98	MW50A18L4	12,793.98	MWR32A22L3	13,022.87	MWR45A15L3	13,022.87	MWR55A18HDL2	13,277.51
MW40A15R5	12,793.98	MW50A18L5	12,793.98	MWR32A22L4	13,022.87	MWR45A15L4	13,022.87	MWR55A18HDL3	13,277.51
MW40A18HDL1	13,048.62	MW50A18R1	12,793.98	MWR32A22L5	13,022.87	MWR45A15L5	13,022.87	MWR55A18HDL4	13,277.51
MW40A18HDL2	13,048.62	MW50A18R2	12,793.98	MWR32A22R1	13,022.87	MWR45A15R1	13,022.87	MWR55A18HDL5	13,277.51
MW40A18HDL3	13,048.62	MW50A18R3	12,793.98	MWR32A22R2	13,022.87	MWR45A15R2	13,022.87	MWR55A18L1	13,022.87
MW40A18HDL4	13,048.62	MW50A18R4	12,793.98	MWR32A22R3	13,022.87	MWR45A15R3	13,022.87	MWR55A18L2	13,022.87
MW40A18HDL5	13,048.62	MW50A18R5	12,793.98	MWR32A22R4	13,022.87	MWR45A15R4	13,022.87	MWR55A18L3	13,022.87
MW40A18L1	12,793.98	MW50A22L1	12,793.98	MWR32A22R5	13,022.87	MWR45A15R5	13,022.87	MWR55A18L4	13,022.87
MW40A18L2	12,793.98	MW50A22L2	12,793.98	MWR36A15L1	13,022.87	MWR45A18HDL1	13,277.51	MWR55A18L5	13,022.87
MW40A18L3	12,793.98	MW50A22L3	12,793.98	MWR36A15L2	13,022.87	MWR45A18HDL2	13,277.51	MWR55A18R1	13,022.87
MW40A18L4	12,793.98	MW50A22L4	12,793.98	MWR36A15L3	13,022.87	MWR45A18HDL3	13,277.51	MWR55A18R2	13,022.87
MW40A18L5	12,793.98	MW50A22L5	12,793.98	MWR36A15L4	13,022.87	MWR45A18HDL4	13,277.51	MWR55A18R3	13,022.87
MW40A18R1	12,793.98	MW50A22R1	12,793.98	MWR36A15L5	13,022.87	MWR45A18HDL5	13,277.51	MWR55A18R4	13,022.87
MW40A18R2	12,793.98	MW50A22R2	12,793.98	MWR36A15R1	13,022.87	MWR45A18L1	13,022.87	MWR55A18R5	13,022.87
MW40A18R3	12,793.98	MW50A22R3	12,793.98	MWR36A15R2	13,022.87	MWR45A18L2	13,022.87	MWR55A22L1	13,022.87
MW40A18R4	12,793.98	MW50A22R4	12,793.98	MWR36A15R3	13,022.87	MWR45A18L3	13,022.87	MWR55A22L2	13,022.87
MW40A18R5	12,793.98	MW50A22R5	12,793.98	MWR36A15R4	13,022.87	MWR45A18L4	13,022.87	MWR55A22L3	13,022.87
MW40A22L1	12,793.98	MW55A15L1	12,793.98	MWR36A15R5	13,022.87	MWR45A18L5	13,022.87	MWR55A22L4	13,022.87
MW40A22L2	12,793.98	MW55A15L2	12,793.98	MWR36A18HDL1	13,277.51	MWR45A18R1	13,022.87	MWR55A22L5	13,022.87
MW40A22L3	12,793.98	MW55A15L3	12,793.98	MWR36A18HDL2	13,277.51	MWR45A18R2	13,022.87	MWR55A22R1	13,022.87
MW40A22L4	12,793.98	MW55A15L4	12,793.98	MWR36A18HDL3	13,277.51	MWR45A18R3	13,022.87	MWR55A22R2	13,022.87
MW40A22L5	12,793.98	MW55A15L5	12,793.98	MWR36A18HDL4	13,277.51	MWR45A18R4	13,022.87	MWR55A22R3	13,022.87
MW40A22R1	12,793.98	MW55A15R1	12,793.98	MWR36A18HDL5	13,277.51	MWR45A18R5	13,022.87	MWR55A22R4	13,022.87
MW40A22R2	12,793.98	MW55A15R2	12,793.98	MWR36A18L1	13,022.87	MWR45A22L1	13,022.87	MWR55A22R5	13,022.87
MW40A22R3	12,793.98	MW55A15R3	12,793.98	MWR36A18L2	13,022.87	MWR45A22L2	13,022.87	SK2015	30,136.32
MW40A22R4	12,793.98	MW55A15R4	12,793.98	MWR36A18L3	13,022.87	MWR45A22L3	13,022.87	SK2017	30,136.32
MW40A22R5	12,793.98	MW55A15R5	12,793.98	MWR36A18L4	13,022.87	MWR45A22L4	13,022.87	SK2215	30,136.32
MW45A15L1	12,793.98	MW55A18HDL1	13,048.62	MWR36A18L5	13,022.87	MWR45A22L5	13,022.87	SK2217	30,136.32
MW45A15L2	12,793.98	MW55A18HDL2	13,048.62	MWR36A18R1	13,022.87	MWR45A22R1	13,022.87	SK2415	30,136.32
MW45A15L3	12,793.98	MW55A18HDL3	13,048.62	MWR36A18R2	13,022.87	MWR45A22R2	13,022.87	SK2417	30,136.32
MW45A15L4	12,793.98	MW55A18HDL4	13,048.62	MWR36A18R3	13,022.87	MWR45A22R3	13,022.87	SK2615	30,136.32
MW45A15L5	12,793.98	MW55A18HDL5	13,048.62	MWR36A18R4	13,022.87	MWR45A22R4	13,022.87	SK2617	30,136.32
MW45A15R1	12,793.98	MW55A18L1	12,793.98	MWR36A18R5	13,022.87	MWR45A22R5	13,022.87	SK2815	30,136.32
MW45A15R2	12,793.98	MW55A18L2	12,793.98	MWR36A22L1	13,022.87	MWR50A15L1	13,022.87	SK2817	30,136.32
MW45A15R3	12,793.98	MW55A18L3	12,793.98	MWR36A22L2	13,022.87	MWR50A15L2	13,022.87	SK3015	30,136.32
MW45A15R4	12,793.98	MW55A18L4	12,793.98	MWR36A22L3	13,022.87	MWR50A15L3	13,022.87	SK3017	30,136.32
MW45A15R5	12,793.98	MW55A18L5	12,793.98	MWR36A22L4	13,022.87	MWR50A15L4	13,022.87	VF12	11,493.32
MW45A18HDL1	13,048.62	MW55A18R1	12,793.98	MWR36A22L5	13,022.87	MWR50A15L5	13,022.87	VF14	11,493.32
MW45A18HDL2	13,048.62	MW55A18R2	12,793.98	MWR36A22R1	13,022.87	MWR50A15R1	13,022.87	VK12	17,668.74
MW45A18HDL3	13,048.62	MW55A18R3	12,793.98	MWR36A22R2	13,022.87	MWR50A15R2	13,022.87	VK14	17,668.74
MW45A18HDL4	13,048.62	MW55A18R4	12,793.98	MWR36A22R3	13,022.87	MWR50A15R3	13,022.87	VS1615	23,178.10
MW45A18HDL5	13,048.62	MW55A18R5	12,793.98	MWR36A22R4	13,022.87	MWR50A15R4	13,022.87	VS1618	23,178.10
MW45A18L1	12,793.98	MW55A22L1	12,793.98	MWR36A22R5	13,022.87	MWR50A15R5	13,022.87	VS1622	23,178.10
MW45A18L2	12,793.98	MW55A22L2	12,793.98	MWR40A15L1	13,022.87	MWR50A18HDL1	13,277.51	VS1815	23,178.10
MW45A18L3	12,793.98	MW55A22L3	12,793.98	MWR40A15L2	13,022.87	MWR50A18HDL2	13,277.51	VS1818	23,178.10
MW45A18L4	12,793.98	MW55A22L4	12,793.98	MWR40A15L3	13,022.87	MWR50A18HDL3	13,277.51	VS1822	23,178.10
MW45A18L5	12,793.98	MW55A22L5	12,793.98	MWR40A15L4	13,022.87	MWR50A18HDL4	13,277.51	VS2015	23,178.10
MW45A18R1	12,793.98	MW55A22R1	12,793.98	MWR40A15L5	13,022.87	MWR50A18HDL5	13,277.51	VS2018	23,178.10
MW45A18R2	12,793.98	MW55A22R2	12,793.98	MWR40A15R1	13,022.87	MWR50A18L1	13,022.87	VS2018R4	23,178.10
MW45A18R3	12,793.98	MW55A22R3	12,793.98	MWR40A15R2	13,022.87	MWR50A18L2	13,022.87	VS2022	23,178.10
MW45A18R4	12,793.98	MW55A22R4	12,793.98	MWR40A15R3	13,022.87	MWR50A18L3	13,022.87	VS22	23,178.10
MW45A18R5	12,793.98	MW55A22R5	12,793.98	MWR40A15R4	13,022.87	MWR50A18L4	13,022.87	VS2215	23,178.10
MW45A22L1	12,793.98	MW55MA13R1	15,902.29	MWR40A15R5	13,022.87	MWR50A18L5	13,022.87	VS2218	23,178.10
MW45A22L2	12,793.98	MWR32A15L1	13,022.87	MWR40A18HDL1	13,277.51	MWR50A18R1	13,022.87	VS2222	23,178.10
MW45A22L3	12,793.98	MWR32A15L2	13,022.87	MWR40A18HDL2	13,277.51	MWR50A18R2	13,022.87	VS2222L5	23,178.10
MW45A22L4	12,793.98	MWR32A15L3	13,022.87	MWR40A18HDL3	13,277.51	MWR50A18R3	13,022.87	VS2415	23,178.10
MW45A22L5	12,793.98	MWR32A15L4	13,022.87	MWR40A18HDL4	13,277.51	MWR50A18R4	13,022.87	VS2418	23,178.10
MW45A22R1	12,793.98	MWR32A15L5	13,022.87	MWR40A18HDL5	13,277.51	MWR50A18R5	13,022.87	VS2418HDL3	23,178.10
MW45A22R2	12,793.98	MWR32A15R1	13,022.87	MWR40A18L1	13,022.87	MWR50A22L1	13,022.87	VS2422	23,178.10
MW45A22R3	12,793.98	MWR32A15R2	13,022.87	MWR40A18L2	13,022.87	MWR50A22L2	13,022.87		
MW45A22R4	12,793.98	MWR32A15R3	13,022.87	MWR40A18L3	13,022.87	MWR50A22L3	13,022.87		
MW45A22R5	12,793.98	MWR32A15R4	13,022.87	MWR40A18L4	13,022.87	MWR50A22L4	13,022.87		
MW50A15L1	12,793.98	MWR32A15R5	13,022.87	MWR40A18L5	13,022.87	MWR50A22L5	13,022.87		

## MS SERIES



## MSZ SERIES



## SK SERIES



## VK SERIES



**U-Pay Freight this Page**



**GENERAL PUMP REPAIR KITS**

K01	KIT 1 - VALVE ASSEMBLY	41.97	K165	KIT INTERMEDIATE RING	33.81	K27	KIT 27-LONG PACKING ASSY	21.93
K01A	KIT 1A,O-RING VA,190-016	2.91	K166	KIT 166 LONG PACKING ASSY	47.43	K27HP	KIT 27-PACKING ASSEMBLY	24.28
K02	KIT 2 - PISTON GUIDE OIL	6.27	K167	KIT LONG PACKING ASSY	47.43	K28	KIT 28- LONG PACKING ASSY	29.53
K03	KIT 3-CRANKSHAFT OIL SEAL	14.84	K168	KIT,REPAIR,UNLOADER,ZK1	83.59	K28HP	KIT 28-PACKING ASSEMBY	31.42
K04	KIT 4 - VALVE CAP BRASS	70.89	K169	VALVE KIT,66 SERIES	137.80	K29	KIT 29-LONG PACKING ASSY	31.88
K05	KIT 5-VALVE CAP NICKEL	110.47	K17	KIT 17 INTERMEDIATE RINGS	51.36	K29HP	KIT 29-PACKING ASSEMBLY	37.64
K06	KIT 6, PISTON BOLT ASSY	22.08	K170	20MM PACKING KIT	108.73	K31	KIT 31 PACKING ASSEMBLY	52.99
K06A	KIT 6A,WASHERS/RI,190-015	6.83	K171	KIT,PACKING,20MM,	80.07	K32	KIT 32-CRANKSHAFT OIL SEA	17.95
K07	KIT 7 - HEAD RING	10.76	K172	22MM PACKING KIT,	108.73	K33	*KIT 33 - VALVE	51.82
K08	KIT 8 - PACKING 20MM	42.18	K173	KIT,PACKING,22MM,	80.07	K34	*KIT 34-ACCUMULATOR ASSEM	73.80
K08HP	KIT 8HP, V-PACKING, 20 x	29.43	K174	KIT,SEAL,16MM (1)	118.88	K35	*KIT 35-PISTON DIAPHRAGM	43.04
K10	KIT 10-PACKING RETAINER	18.11	K175	*KIT,PACKING,16MM (3)	81.75	K37	KIT 37 OIL SEAL	23.36
K101T	PACKING KIT,TEFLON,	171.21	K176	KIT,PACKING,18MM (3)	84.51	K38	KIT 38-36MM SHORT PACKING	73.80
K102	KIT-102 TT UNLOADER MAINT	99.76	K177	KIT,FLOW,B/I UNLOADER,	88.18	K39	KIT 39 - PACKING ASSEMBLY	78.95
K103	*KIT 103	19.69	K178	KIT,REPAIR,UNLDR,ZK3608	42.02	K40	KIT 40 PACKING RETAINER	77.57
K105	KIT 105 P10 MAINTENANCE	34.94	K180	PACKING KIT,18MM	132.75	K41	KIT 41- HEAD RING 38 MM	31.98
K106	KIT-106 - VALVE CAP	125.72	K181	KIT,LP SEAL,HP SEAL,	94.71	K42	KIT 42-INTERMEDIATE RING	56.00
K107	KIT 107 PISTON BOLT	45.14	K182	KIT,PACKING,24MM,	80.07	K43	KIT 43 - VALVE	186.76
K108	KIT 108 - HEAD RING (6)	7.45	K183	KIT,UNLDR,BUILT-IN,FLOW	156.32	K43A	*KIT 43A,O-RING V,190-017	8.87
K109	KIT 109 - PACKING 16MM	89.96	K184	KIT,UNLDR,BUILT-IN,TRPPD	81.80	K44	KIT 44-PISTON ROD OIL SEA	29.07
K109RD	KIT 109RD PACKING 16MM,	166.16	K187	KIT,REPAIR,INTERNAL	89.91	K47	KIT 47- PACKING RETAINER	85.27
K11	KIT 11-HEAD RINGS	9.44	K19	KIT 19-SHORT PACKING 20MM	38.10	K48	KIT 48- HEAD RING 45MM	30.70
K110	KIT-110 INTERMEDIATE RING	62.17	K191	KIT,REPAIR,UNLOADER,	98.18	K50	*KIT 50-VALVE MAINTENANCE	28.76
K111	KIT 111 PACKING RETAINER	58.65	K192	KIT,VALVE,SS,SIX PIECES	127.30	K51	KIT 51 TIMAX MAINTENANCE	56.51
K112	KIT 112-LONG PACKING ASSY	84.41	K196	SEALS,HP,PACKINGS,15MM	45.85	K52	KIT 52 PIMATIC/P11 GUN	30.70
K113	KIT 113-SHORT PACKING ASSY	126.63	K197	SEALS,HP,PACKINGS,18MM	55.74	K54	KIT 54 - BOLT KIT	37.28
K114	KIT 114-PACKING RETAINER	195.43	K198	RING,INTERMEDIATE,15MM	29.38	K56	*KIT 56-S1 VALVE MAINTENA	12.44
K115	KIT 115 PACKING ASSEMBLY	138.57	K199	RING,INTERMEDIATE,18MM	29.38	K57	KIT,PACKING RETAINER &	75.48
K116	*KIT 116-P3 MAINTENANCE	31.98	K19HP	KIT 19HP, V-PACKING, 20 x	31.06	K58	KIT 58 - K5 MAINTENANCE	61.35
K118	KIT 118 SHORT PACKING	12.80	K19RD	KIT 19RD SHORT PACKING	95.68	K59	KIT 59 K3 MAINTENANCE	57.17
K119	KIT 119 LNG PACKING	13.92	K20	KIT-20 INTERMEDIATE RING	19.02	K60	KIT 60 - K5 COMPLETE REUB	89.15
K12	KIT 12 - PACKING 22MM	49.22	K200	SEALS,LP,15MM 60 SERIES	26.98	K61	KIT-61 K3 COMPLETE REBUILD	93.89
K120	KIT 120 - UNLOADER MAINT	27.08	K201	KIT,VALVE,HIGH	78.44	K62	KIT 62 - VALVE (6)	119.14
K121	KIT 121 K9 MAINTENANCE	237.00	K2012	KIT,VALVE,INLET,71 SERIES	319.36	K63	KIT 63 - PACKING 30MM	78.23
K122	KIT, VALVE ASSY - T4251	365.11	K2013	KIT,VALVE,OUTLET,71	324.00	K64	KIT 64 PACKING RETAINER	87.01
K123	KIT, VALVE	51.20	K202	KIT,SEALS,LP&HP,HIGH	233.12	K65	KIT 65-INTERMEDIATE RING	11.53
K124	KIT, VALVE CAP, EZ	69.51	K203	KIT,SEAL ASSEMBLY,HIGH	105.26	K66	KIT 66-INTERMEDIATE RING	79.10
K126	KIT 125 PACKING RETAINER	31.98	K2030	KIT,VALVE,70 SERIES	599.15	K67	KIT 67-SHORT PACKING ASSY	83.74
K126	KIT 126-PACKING RETAINER	31.98	K2031	KIT,SEALS,HT,70 SERIES	536.11	K69	KIT 69,SHORT PACKING ASSY	61.20
K127	KIT 127,SHORT PACKING ASSY	59.87	K2032	KIT,PACKING,HT,70 SERIES	218.18	K70	KIT 70 - K7 MAINTENANCE	88.89
K128	KIT, INTERMEDIATE RING	31.21	K2033	KIT,SEALS,PACKING,HT	555.34	K71	KIT,INTERMEDIATE RING,	66.76
K129	EZ HEAD RINGS,EZ SERIES	7.65	K2034	KIT,PACKING,HT,71 SERIES	266.32	K72	KIT 72 - MAINTENANCE	29.07
K12HP	KIT 12HP, V-PACKING, 22 x	44.78	K204	KIT,SEAL,HIGH PRESSURE,	205.58	K74	KIT 74 PISTON BOLT	88.43
K130	KIT,15MM Long Packing Assy	44.73	K205	KIT,SEAL ASSEMBLY,63 HT	92.21	K75	KIT 75-INTERMEDIATE RING	107.46
K130HP	KIT 130-PACKING ASSEMBLY	36.36	K206	KIT,SEAL,HIGH PRESSURE,	272.85	K76	KIT 76-PACKING RETAINER	171.26
K131	KIT 131,18MM Packing Assy	54.57	K207	KIT,SEAL ASSEMBLY,20MM,	128.27	K77	KIT-77 PACKING W/RESTOP 2	91.14
K132	KIT 132 - UNLOADER KIT	24.79	K208	KIT,SEAL,HIGH PRESSURE,	272.85	K78	KIT 78 LONG PACKING ASSY	128.88
K133	KIT 133 - VALVE CAP	16.12	K209	KIT,SEAL ASSEMBLY,22MM,	128.27	K78HP	KIT 78-PACKING ASSEMBLY	105.93
K134	KIT 134 - VALVE REPAIR	25.86	K21	KIT 21 - HEAD RINGS	8.06	K79	KIT 79 - PACKING W/RESTOP	114.09
K135	*PACKING KIT, SINTEX	15.61	K210	KIT,SEAL,HIGH PRESSURE,	286.67	K80	KIT 80-LONG PACKING ASSY	85.88
K136	KIT 136-PISTON ROD OIL	17.95	K211	KIT,SEAL ASSEMBLY,24MM,	132.75	K81	KIT 81-INTERMEDIATE RING	111.89
K137	KIT, REPAIR, ZUI UNLOADER	86.85	K212	KIT,SEAL,HIGH PRESSURE,	423.10	K82	KIT 82 LONG PACKING W/RES	73.64
K139	KIT 139 PACKING RETAINER	30.24	K213	KIT,SEAL,ASSEMBLY,69 HT	178.60	K82HP	KIT 82-PACKING ASSEMBLY	53.35
K14	KIT 14-PACKING RETAINER	14.28	K214	KIT,PACKINGS,63SS,15MM	279.68	K83	KIT 83 - OIL SEAL	16.83
K140	KIT 140 LONG PACKING ASSY	20.30	K215	KIT,PACKING,COMPLETE,15MM	200.74	K84	KIT 84 - VALVE CAP	57.53
K141	KIT 141 PACKING 18 MM	31.11	K216	KIT,PACKING,COMPLETE,18MM	193.44	K85	KIT 85 - COMPLETE PACKING	14.74
K142	KIT,TRAPPED PRESSURE,	125.87	K217	KIT,PACKING,SS,20MM,66 SS	238.53	K86	KIT 86 SHORT PACKING	20.30
K143	*KIT, REPAIR FOR HX VALVE	40.24	K218	KIT,PACKING,SS,22MM,66 SS	238.53	K87	KIT 87-PACKING LESS BRASS	20.09
K146	KIT 146 - PACKING	12.65	K219	KIT,PACKING,HT,24MM	269.13	K88	KIT,PACKING,W/RESTOP RING	45.03
K147	KIT 147 - OIL SEAL	14.64	K22	KIT-22 PACKING RETAINER	14.08	K88HP	KIT,HIGH PRESSURE PACKING	45.65
K148	KIT 148,SHORT PACKING ASSY	69.05	K220	KIT,HOT,VALVE AND SEALS,	249.29	K89	KIT 89-INTERMEDIATE RING	29.17
K148RD	KIT 148RD,PACKING 22MM,	233.84	K220A	KIT,SEAL,20MM,HOT	163.00	K90	KIT 90 -HEAD RING 5110005	5.46
K149	KIT 149,INTERMEDIATE RING	42.38	K222	KIT,SEAL,22MM,HIGH	249.29	K91	KIT 91 - PACKING RETAINER	29.17
K15	KIT 15 HEAD RING 24MM	7.65	K225	SEALS,LP,18MM 60 SERIES	26.98	K910	KIT 910 CW LP PACKING	45.95
K150	KIT, VALVE, T5050	182.99	K226	KIT,PACKING,COMPLETE,15MM	35.50	K9101A	KIT 9101A, CW LONG PACKG	36.92
K15066	KIT,VALVE,	182.99	K227	KIT,PACKING,COMPLETE,18MM	37.89	K911	KIT 911-SEAL RETAINER	45.03
K151	KIT, LONG PACKING, T5050	75.68	K228	KIT,VALVE,SS,SIX PIECES,	192.93	K92	KIT 92-LONG PACKING ASSY	42.18
K152	KIT,PACKING RETAINER	69.36	K23	KIT 23-PISTON ROD OIL SEA	17.09	K93	KIT 93-CONTROL SET W2	32.95
K153	KIT, SHORT PACKING	81.45	K235	KIT,ASSEMBLY,UPPER	70.02	K939	KIT 939-PACKING ASSEMBLY	82.62
K154	KIT,INTERMEDIATE RING	80.68	K236	KIT,ASSEMBLY,COMPLETE	103.53	K94	KIT 94 - CONTROL SET FOR	8.36
K155	KIT-155,HEAD RING, 13MM	6.43	K237	KIT,ASSEMBLY,INJECTOR	13.77	K940	KIT 940,PACKING RETAINER	116.08
K156	KIT, LONG PACKING ASSY	82.42	K238	KIT,SEAL,HT,20MM	292.23	K942	KIT,INTERMEDIATE RING	120.67
K158	KIT-158, VALVE CAP	112.20	K239	KIT,ASSEMBLY,SEAL,HT	264.49	K943	KIT,VALVE CAR WASH	162.13
K159	KIT PISTON ROD OIL SEAL	17.34	K24	KIT 24 - PISTON ROD OIL S	20.30	K95	KIT 95 - KR UNLOADER	55.79
K16	KIT 16 - PACKING 24MM	73.70	K240	KIT,ASSEMBLY,SEAL,HT	257.81	K96	KIT 96-LONG PACKING ASSY	11.53
K160	KIT SHORT PACKING,15MM	76.50	K243	KIT,SEALS,60 SER.,HT	293.66	K967	KIT 967,PACKING ASSY,	82.98
K161	KIT SHORT PACKING, 18MM	76.50	K244	KIT,ASSEMBLY,SEAL,60	136.58	K969	KIT 969, CW SHORT PACKING	62.99
K162	KIT 162 - SEAL RETAINER	31.06	K25	KIT 25- PACKING 22MM	26.93	K97	KIT 97 - SHORT PACKING	16.52
K163	KIT 163 - SEAL RETAINER	31.06	K25	KIT 25- PACKING 22MM	26.93	K98	KIT 98 - W1 MAINTENANCE	96.29
K164	KIT INTERMEDIATE RING	33.81	K26	KIT 26 - PISTON BOLT	20.96	K99	X KIT,UI MANIFOLD	14.69

**POPULAR KIT TOOLS**

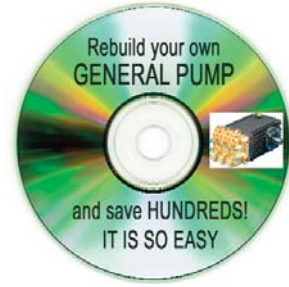

**PUMP REBUILDING 'CD'**

How much did you say that you have spent over the years having someone else rebuild your

**GENERAL PUMP?**

Not any more! How about 10 minutes to change all the packings & valves?

Can you live with that?

**ORDER #GPV-101 \$9.95**

**PACKING EXTRACTION KIT**



INCLUDES: Slide Hammer that attaches to extractor socket & extractor sockets that fit:

15mm, 18mm, 20mm, 22mm & 24mm.

PART # PRICE  
1007 \$49.77

**PACKING INSERTION KIT**

For All General Pumps

Getting the packing out is one thing...  
... getting them back in is another



PART # PRICE  
1063 \$14.76





# ANNOVI REVERBERI

The Power of Experience



## A-R KITS

AR1808	52.12	AR2156	46.83	AR2597	15.18
AR1811	16.62	AR2157	19.57	AR2598	15.18
AR1815	13.36	AR2167	29.34	AR2599	21.76
AR1816	14.11	AR2186	36.37	AR2606	56.67
AR1819	63.93	AR2188	36.30	AR2622	18.43
AR1820	12.22	AR2189	51.67	AR2623	73.93
AR1824	22.53	AR2190	14.11	AR2624	80.82
AR1827	51.60	AR2191	10.41	AR2631	67.95
AR1828	48.34	AR2233	15.63	AR2674	25.47
AR1829	17.91	AR2234	29.26	AR2683	29.04
AR1846	64.62	AR2235	20.32	AR2687	23.65
AR1848	71.20	AR2236	17.22	AR2740	10.48
AR1855	52.80	AR2237	15.63	AR2741	71.35
AR1856	57.04	AR2332	17.61	AR2744	21.76
AR1859	34.93	AR2503	58.03	AR2745	11.25
AR1860	40.39	AR2504	40.84	AR2747	77.79
AR1863	26.23	AR2508	24.94	AR2781	50.53
AR1864	42.13	AR2511	13.89	AR2784	76.20
AR1865	35.47	AR2514	57.64	AR2786	35.62
AR1866	69.09	AR2528	41.29	AR2787	48.03
AR1872	36.00	AR2529	44.17	AR2797	23.20
AR1873	40.00	AR2577	23.13	AR2798	55.00
AR1874	71.20	AR2581	24.19	AR2799	22.14
AR1916	16.17	AR2582	39.55	AR2800	57.12
AR1922	26.53	AR2583	16.02	AR2825	71.88
AR1925	32.74	AR2584	39.78	AR2826	71.88
AR1930	33.27	AR2586	21.39	AR2855	16.84
AR2040	22.14	AR2587	43.11	AR2856	19.80
AR2121	25.17	AR2588	20.32	AR2864	50.16
AR2125	42.13	AR2591	21.84	AR2868	21.84
AR2136	25.32	AR2592	15.70	AR2869	42.13
AR2155	23.20	AR2593	32.52	AR2873	38.95

## A-R PUMPS AND PRICING

RC1117N	210.34	RKA7G20HEF17	459.15	RW21	351.60	XMV3G25DF25	273.79
RC1317N	210.34	RKA7G20HN	399.73	SJV25G27DF7	223.88	XMV3G25EF33	280.91
RCA25G25N	210.34	RKA7G20HN	399.73	SJV25G27DF7M22	223.88	XMV3G27DF25	273.79
RCA2G25EF8	219.44	RKASS23G15EF17	1562.77	SJV3G27DEZ	238.13	XMV3G30DF24	285.66
RCA2G25EF8SX	219.44	RKASS23G15EF33	1562.77	SJV3G27DF7	233.38	XT814N	266.65
RCA35G16EF8	219.44	RKASS23G15N	1491.55	SRMW22G26EZ	124.76	XTA05G10EBAF8	304.80
RCA35G25N	210.34	RKV35G30ADF24	356.96	SRMW22G26EZSX	124.76	XTA1G15EF8	280.91
RCA3G25EF8	219.44	RKV35G40HDF24	404.49	SXMA3G35EF17	347.46	XTA2G15EBAF8	280.91
RCA3G25N	210.34	RKV45G32DF24	390.23	SXMA4G30EF17	347.46	XTA2G15NBA	266.65
RCV25G25DF7	219.44	RKV45G37DF24	390.23	SXMV35G40DF24	311.80	XTA2G22EF8	299.93
RCV25G25DF7S	219.44	RKV45G40HDF24	404.49	SXMV3G40DF24	311.80	XTA2G22N	285.66
RCV25G27DF7	219.44	RKV4G37DF24	325.00	SXMV4G40DF24	311.80	XTA3G16EBAF8	290.42
RCV2G25DF7	219.44	RKV4G40HDF24	360.00	SXW1535	605.00	XTA3G16N	273.79
RCV2G25EF8	219.44	RKV55G40HDF24	404.49	SXW2135	605.00	XTA3G19EF8	307.05
RCV35G25DF7	219.44	RKV5G40HDF24	404.49	SXWA4G50	701.54	XTA3G19N	290.42
RCV3G25DF7	219.44	RKW1514N	501.92	SXWA55G50	701.54	XTA4G15EBAF8	309.43
RCV3G25EF8	219.44	RMV25G30D	162.10	SXWA7G50	701.54	XTV05G10EF8	304.80
RHW1515N	763.77	RMV2G25D	147.83	WHW2115N	940.51	XTV2G15DBAF7	280.91
RK1528HN	360.00	RMW25G25D	147.83	WHWL3815N	940.51	XTV2G15EBAF8	280.91
RK1828HN	399.73	RMW25G28EZSX	166.84	WHWL4215N	940.51	XTV2G22EF8	299.93
RK2120NL	399.73	RMW2G24	114.57	WHWL5015N	940.51	XTV3G16EF8	280.91
RKA35G25N	375.96	RMW2G25D	147.83	XHW1117N	665.00	XTV3G22DF7	299.93
RKA35G30EF17	399.73	RR1520N	263.79	XJV2G15EF8	233.38	XTV3G22EF8	299.93
RKA35G30N	375.96	RR1816N	263.79	XJV3G20EF8	233.38	XW3025N	623.12
RKA35G40HEF1	449.64	RRA35G30N	263.79	XM1117N	266.65	XWA9G30N	623.12
RKA35G40HN	392.61	RRA3G30EF17	277.64	XM1515N	273.79	XWAM4G40N	539.94
RKA45G35HN	392.61	RRA4G30EF17	277.64	XMA25G18EF33	280.91	XWAM55G40N	539.94
RKA48G30EF17	449.64	RRA4G30N	263.79	XMA2G22EF33	280.91	XWAM7G40N	594.60
RKA4G20EF17	399.73	RRA55G26EF17	277.64	XMA35G22N	273.79	XWAM8G35N	554.60
RKA4G30AN	340.33	RRA55G30N	263.79	XMA35G25EF17	316.56	XWF2620N	675.39
RKA4G30EF17	399.73	RRV35G36DF24	268.41	XMA35G25N	266.65	XWF3020N	675.39
RKA4G30HEF17	449.64	RRV3G36DF24	268.41	XMA3G18EF33	280.91	XWF3617N	675.39
RKA4G30N	375.96	RRV4G36DF24	268.41	XMA3G25N	266.65	XWL4121N	730.05
RKA4G35N	392.61	RSV25G25DF25	290.42	XMA3G30EF17	316.56	XWL4215N	675.39
RKA4G35NL	402.11	RSV35G35DF40	311.80	XMA4G20N	273.79	XWL5015N	730.05
RKA4G40HN	392.61	RSV3G25DF25	290.42	XMV25G26DF25	273.79	XWLA13G15N	675.39
RKA4G40HNL	402.11	RSV3G30DF40	311.80	XMV2G25EF33	280.91	XWM1530N	539.94
RKA55G13EF17	442.50	RSV4G40DF40	311.80	XMV35G20EF33	280.91	XWM2128N	539.94
RKA55G30HN	399.73	RW15	351.60	XMV35G25DF25	273.79	XWM2623N	594.60
RKA65G20HN	399.73	RW15	351.60	XMV35G25DF33	280.91	XWT2120N	675.39

**U-Pay Freight on Pumps**



# An unborn animal will never have to die in an animal shelter...

Gloss Enhancing House Wash for Cold Water

Hi-Solvent Truck Wash / Degreaser

## POWER HOUSE

55 GALLONS  
\$99.95

Specifically formulated for  
Cold Water Equipment & 'Hard Water' Areas

POWER HOUSE was developed for cold water washing where hard water is present. This product contains an over abundance of water softening chelating agents which makes it well suited for hard water areas throughout the country.

Typically hot water is the preferred method of applying and rinsing cleaning chemicals from the surface. However, you will find POWER HOUSE to work equally as well in a cold water environment. This is especially important in States like Florida, Georgia & Texas where it is not uncommon to see surface temperatures in the 130 degree range. Since heat generates alkalinity you can see how dangerous it can be when detergent is applied to the surface using a hot water pressure washer. Quite often this method results in alkaline shock where the water from the detergent evaporates and damages the surface before the operator has time to rinse. More often than not this damage is irreversible. Use Power house to avoid this danger.

The dispersant utilized in POWER HOUSE allows for a high concentration of specific builders and surfactants which will completely emulsify carbonaceous as well as general 'fall-out' pollutants commonly found in areas that see a lot of motor vehicle traffic. POWER HOUSE contains a high volume of our SuperFlo Polymer which accounts for it's surface gloss.

Although POWER HOUSE is considered a Super Concentrate you will find that it will provide a great wash/rinse cycle while remaining gentle on the surface.

POWER HOUSE is a unique blend of specialty surfactants and alkalis specifically formulated for the Professional Exterior House Washing Industry. It acts by first wetting and chelating pollutants and then holding them in suspension until the surface is thoroughly rinsed. POWER HOUSE is less aggressive on surface and vegetation than typical cleaners used in this field but will achieve superior cleaning results.

5 GAL #PH5 \$15.00  
20 GAL #PH20 \$45.00  
55 GAL #PH55 \$99.95

## VIPER

55 GALLONS  
\$99.95

Specifically formulated for  
Truck & Bus Washing Industry  
Non-Caustic Degreaser  
with Gloss Enhancers for Dull Surfaces

Viper is a specialty product specifically formulated for the Truck Washing & Bus Washing Industry where exhaust fumes have become attached to the stack side of the trailer body & rear engine areas of City Buses. Coupled with carbon release activating solvents and rinse aids, Viper also finds itself being utilized in other areas where the heavy build-up of grease & oil is present. Garage Floors, Vehicle Maintenance Shops, and Service Stations are just a few of the many areas where Viper is utilized.

Viper is preferred by many professionals who have scheduled cleaning of commercial vehicles with a frequency of weekly or every other week service. It is a quick cleaner and a fast rinser. Areas where this product is being utilized is on Hertz, UPS, Ryder and many other Nationally known vehicle accounts.

Viper exhibits excellent wetting, chelating, rinsing and emulsifying properties. It has the ability to hold pollutants in suspension during the wash process and it's rinsability makes it an ideal product when using either cold or hot water equipment.

Viper's horsepower is derived from a group of Specialty Gloss Enhancers, Spot Free Rinse Aids, and a unique blend of surfactants which are not commonly found in the detergent industry.

Viper comes packaged in a two-part system. One part is approximately forty (40) pounds of Base Product. The second part is one gallon of Carbon Release Activator. The two combined will make 55 gallons of a super concentrate.

5 GAL #VIP5 \$15.00  
20 GAL #VIP20 \$45.00  
55 GAL #VIP55 \$99.95

## EXPERIENCE THE POWER OF ZOLOID 'CROSS-LINKED' SURFACTANTS

# Z'GREASER

55 GALLONS  
\$149.95

THE INDUSTRY'S MOST POWERFUL  
DEGREASING FORMULA

**If you find yourself in a real 'bind' over removing oils and grease you will be amazed at what z'Greaser will 'cut'!**

z'Greaser is the most powerful non-caustic formula in the degreasing chemical industry. Over 40 pounds of powder plus liquid activators are blended together to make 55 Gallons of liquid concentrate.

In general, z'Greaser was formulated to disrupt the surface membrane of grease in order to first free and then solubilize membrane-bound pollutants while, at the same time, holding those pollutants in solution and not allowing them to redeposit themselves elsewhere on the surface prior to rinsing.

Because of its wide range of a unique Zoloid Surfactant which is produced by EnviroSpec, z'Greaser can be utilized in a wide variety of cleaning applications. We have tested this product extensively in the truck washing industry and found that at a final product to surface dilution level of 225 parts water to 1 part product, z'Greaser produced the best results in 98% of our test models. In the heavy equipment degreasing industry 90 parts water to 1 part z'Greaser proved to be the best dilution rate.

Although expensive on a per unit basis, when you consider the unlimited cleaning projects that can be performed by z'Greaser at these phenomenal dilution rates you can readily see that this is really one of the most cost effective products on the market. It is not uncommon to have 1 drum of z'Greaser Concentrate to equal 5 drums of what is presently being sold to the Professional Mobile Wash Industry by other manufacturers.

5 GAL #ZG5 \$25.00  
20 GAL #ZG20 \$75.00  
55 GAL #ZG55 \$149.95

...so please Spay or Neuter your pet.

# FIBER

27 GALLONS  
**\$39.00**



Specifically Formulated to Rejuvenate Wood Fibers

**FIBER** is the purest form of Oxygenated Cleaner & the only oxygenated cleaner with an Orange Solvent

We are widely regarded as one of the leading global experts in the development and implementation of Green cleaning solutions and the invention Fiber-X, our latest wood rejuvenator, is a good example why most experts turn to EnviroSpec to help them with their toughest cleaning projects.

Fiber-X is a blend of oxygenators, orange peel solvents and cross-linked surfactants that break the degenerative cycle of drying & decaying wood fibers that begins when environmental factors come into play. When used as directed Fiber-X breaks this cycle by allowing the wood to breath more efficiently. The orange peel solvents help to penetrate and eliminate any existing wood destroying bacteria by weakening it's cell wall. When the cell wall is weakened or disrupted, it can no longer function. This forces the cell to burst due to osmotic effects (water rushing into the cell). At this point wood fibers can recapture their shape while continuing to exist in a harsh outdoor environment.

For best results place 1/2 to 3/4 pound of product into a clean 5 gallon pail filled with slightly warm water. Pour in the product and stir 8-10 times. At this point approximately 80% of the powder will still be at the bottom of the pail. Apply by placing the chemical pick-up line from a 12V or 115V ShruFlo or Flojet pump at the bottom of the pail and begin to drench the wood surface. By the time you have completely drained the pail all of the product will have been solubilized through its own oxygenation process. Allow to stand for approximately 15-20 minutes and rinse.

In some cases, especially with pressure treated wood, the surface will 'fuzz.' This will normally return to its natural state in a few days. Occasionally a light sanding may be required. It is because of this that we recommend a 1/2 pound per gallon of warm water for pressure treated wood.

5 GAL #FIB5 \$17.00  
27 GAL #FIB27 \$39.00  
55 GAL #FIB55 \$79.00

100% of the net profits that are generated from the EnviroSpec Chemical Division are donated to...



Suzie's Friends Animal Sanctuary  
Homerville, GA

## PRO-BLEND

Quick Rinsing Truck & House Wash loaded with Water Softners

55 GALLONS  
**\$99.95**

'Film Free' Cleaning in the Truck & House Washing Industry

SuperFlo Polymer Gloss Enhancers - Water Softening Additives - Nonionic Surfactant Base

Pro Blend is, by far, the most effective non-caustic, film free cleaning detergent concentrate in the professional contract cleaning industry. When used properly, the operator can expect to remove 85% to 90% of all road film from both tractor and trailer bodies that are cleaned on a regular basis.

Pro Blend exhibits excellent wetting, chelating, rinsing and emulsification properties due to its high concentration of our SuperFlo Polymer Complex System. This exotic complex is formulated from a variety of unique dispersants, hydrotopes, and surfactants which are not commonly found in detergent formulations.

The power from Pro Blend originates from a wide variety of uniquely charged ion surfactants, which will alter a positive charged substrate to a negative charge upon contact. This bond breaking function will provide the operator with a one-step cleaning process, rather than the typical acid-alkaline or two-step process that is presently being utilized throughout the industry. The advantages of single step cleaning, using Pro Blend, are twofold, 1) the contractor will be able to provide his/her customer with a much higher quality service, at a much lower cost, or should they choose, greatly enhance their own profit margin, and 2) eliminates the possibility of etching glass which can easily happen when using solutions with a hydrofluoric acid content.

5 GAL #PB5 \$15.00  
20 GAL #PB20 \$45.00  
55 GAL #PB55 \$99.95

On this page we pay the freight on \$50.00 Web Orders or \$200.00 Call-in Orders



## PRODIGY

55 GALLONS  
\$99.95

How good is it? We have one customer who purchases 5,500 drum packs a year!

### CONTAINS SUPER GLOSS ENHANCERS

Prodigy is, by far, one of the highest non-caustic detergent concentrations available in the industry. Prodigy exhibits excellent wetting, chelating, rinsing, and emulsification properties due to its high concentration of our SuperFlo Polymer Complex System. This exotic complex is formulated from a variety of unique dispersants, hydrotopes, and surfactants, which are not commonly found in detergent formulations.

The general rule of thumb in detergent formulation is as follows: Approximately 1 gallon of water will hold approximately 1 pound of powder before separation begins. If your product begins to separate using this method, more often than not, your product has been camouflaged with what is known in our industry as "fillers". Fillers provide little to no value to the products integrity and/or performance. They are used primarily to add weight and increase the bottom line profit for the manufacturer. Using the 1 pound per 1 gallon rule, you can see the potency of Prodigy when you consider that we are able to thoroughly dissolve up to 2.3 pounds of Prodigy into 1 gallon of water without separation. To our knowledge, no other company can make this claim. The advantage of these concentration levels are twofold: 1) the contractor is now able to clean substrates that normally require the use of caustic cleaners and 2) work faster and safer, which increases your bottom line.

As the leader in contract cleaner formulations, EnviroSpec goes to great lengths in providing products that are both environment friendly as well as effective, an attitude not commonly found in such a demanding industry.

Since PRODIGY came out in 1986 it has grown to be the most asked for Truck Wash Detergent in the Mobile Wash Industry.

5 GAL #PRO5 \$15.00  
20 GAL #PRO20 \$40.00  
55 GAL #PRO55 \$99.95

## MR. MUSCLE

55 GALLONS  
\$159.95

What is Mr. Muscle?

PRODIGY with extra Grease Cutters

### CONTAINS 'EB' SOLVENT BOOSTERS

### QUICK RINSE ADDITIVES

### AND EXTRA GLOSS ENHANCERS

Mr. Muscle has a 40 pound base of Prodigy, the industry's #1 Selling Tractor/Trailer Wash, plus 2.5 gallons of solvent/surfactant additive that really cranks up the horsepower and safely cuts through the heavy build-up of carbonaceous pollutants such as the exhaust typically found on over-the-road trailer bodies and 'fifth-wheel grease!'

Mr. Muscle runs circles around all the degreasers found in the marketplace and at a price that is well below what you would expect to pay for such a product.

In addition, you will find it to work extremely well with both hot and cold water systems. The addition of SpeedX-777 which is part of the liquid additive makes rinsing a breeze.

Mr. Muscle exhibits excellent wetting, chelating, rinsing, and emulsification properties due to its high concentration of our SuperFlo Polymer Complex System. This exotic complex is formulated from a variety of unique dispersants, hydrotopes and rinse aids which are not commonly found in detergent formulations.

Typical applications for the concentrate are:

Tractor/Trailer Bodies, Engines, Fork Lifts,  
Garage Floors, Rail Cars

EnviroSpec goes to great lengths in providing products that are both environment friendly as well as effective.

5 GAL #MRM5 \$25.00  
20 GAL #MRM20 \$75.00  
55 GAL #MRM55 \$159.95

## EMULSIFIER PLUS

The Industry's #1 Selling House Wash

55 GALLONS  
\$99.95

### BLEACH FRIENDLY DETERGENT WITH GLOSS ENHANCERS

For the very best of all worlds start with 4 gallons of Emulsifier Plus to 1 Gallon of Bleach

Emulsifier Plus - is one of the Original House Wash Formulas developed by EnviroSpec. Our dilemma at the onset of its development stages were: we all know bleach works better than anything for killing and cleaning mold & mildew but we also knew that bleach does absolutely nothing about cleaning carbonaceous pollutants such as exhaust carbons, dirt, grease and grime. The task was - how to do both at the same time!

Bleach, for the most part, does not like to be blended with other chemical products and many of the chemical products found in the professional mobile wash industry can create a serious explosive situation when mixed with sodium hypochlorite (bleach). Emulsifier Plus, on the other hand, is the answer to both the safety issue as well as the cleaning problem. These two products work extremely well together when blended and applied in accordance with the EnviroSpec instructions. Have the best of both worlds - Clean and Kill Mildew and Clean All the other Pollutants typically found on an exterior substrate. And do it all in one pass!

Emulsifier Plus has a pH of around 11.8 to 12.0 in a 1% solution. This unique blend of Surfactants & Builders has been specifically formulated for the House Wash Industry as a stand alone detergent or a detergent additive to be blended together with Bleach.

Emulsifier Plus works great on removing heavy build-ups of grease, grime and general fallout pollutants generally found in high traffic areas and exhibits excellent wetting, chelating, rinsing, and emulsification properties. Its ability to hold pollutants in suspension during the wash process makes it an ideal product when using either hot or cold water pressure washers.

5 GAL #EMUP5 \$29.95  
20 GAL #EMUP20 \$59.95  
55 GAL #EMUP55 \$99.95

## PREMIUM 'HIGH YIELD' DETERGENT WITH LAUROX LO



55 GALLONS  
**\$148.00**

High Foaming Blend of Emulsifiers, Solvents & 'Quick Rinse' Agents. It is loaded with Water Softeners, Static Reducing Additives & Gloss Enhancers.

### FORMULATION OBJECTIVE: **SPEED IN CLEANING AND RINSING**

BLUE LIGHTENING is the result of blending the very best 'job specific' ingredients that cover every aspect of a cleaning task that will insure the 'perfect clean.' We wanted speed - which meant we had to get the product on the surface - have it do it's job - and get it off the surface quickly.

We added a large amount of LAUROX LO which quickly wets the surface while at the same time generates a substantial 'foam bed' that keeps the soil suspended in the liquid so that it does not redeposit itself on the surface during the cleaning process.

It is formulated with 'top shelf builders.' Not one 'builder' but several are utilized and each has a specific purpose. Some provide alkalinity to aid in cleaning & keeping emulsified soil in suspension. Others emulsify oil and grease and overcome problems associated with water hardness.

BLUE LIGHTENING has a generous amount of SuperFlo Polymer. It is this product that has placed EnviroSpec as the leader in Gloss Enhancing detergent chemistry.

BLUE LIGHTENING can be used in virtually every type of cleaning environment. Truck Washing where heavy build-ups of exhaust carbon and 'road static' are present, House Washing, Brick and Masonry Cleaning, Car Washing, Wood Surfaces & Engine Degreasing are just a few of the cleaning tasks that are easily handled by Blue Lightening.

- 5 GAL #BL5 \$20.00
- 20 GAL #BL20 \$60.00
- 55 GAL #BL55 \$148.00

### FOR ACID DAMAGED GLASS

## GLASS DE-ETCH

Jewelers use a lesser grade of this compound to polish out scratches on expensive crystal.

Glass De-Etch is a Rare Earth Glass/Crystal Polishing Compound to be used when severe acid damaged has occurred to any glass.

#### USE INSTRUCTIONS:

Mix with water to the consistency of pancake batter and wipe on windshield. Using a electric buffer with a low pile polishing pad buff briskly into the surface. Work in small areas.

A high stock removal rate, which is partially due to the narrow particle distribution resulting in a low percentage of fines, leaves a clear, bright finish.

#ZPGDE \$44.95 - Enough for 10 Windshields

### FOR SOAP DAMAGED GLASS

## SCUM BUSTER

**Did you let soap dry on the glass?  
Yes Scum Buster Really Works!**

Scum Buster is manufactured from the world's finest Rare Earth Glass Polishing Compounds.

#### USE INSTRUCTIONS:

Mix with water to the consistency of warm syrup. Wipe or paint onto glass and briskly polish surface.

#ZPSB \$44.95 - Enough for an entire house

### Exhaust Carbons Explode from the Surface!

## 'OCB' EMULSIFIER

**"OIL EATING" Super Solvent-Surfactant  
for those 'nasty' Truck Fleets  
that are loaded with exhaust carbon.**

**'OCB' Emulsifier can be added to any  
Drum Pack of EnviroSpec Detergent  
in concentration levels of  
1 Gallon to 55 Gallons.**

Ask any Professional Mobile Washer who washes trucks and they will tell you that not a 'shift' goes by without running into at least one account that is loaded with exhaust carbon on the 'stack side' of the trailer. When this happens it takes forever to finish that account and when you think you are through...

...the job still looks terrible!

All of the EnviroSpec Truck Wash Products are loaded with 'OBC' Emulsifier already but occasionally even that is not enough

Add 1 Gallon of 'OCB' Emulsifier and watch the carbon & grease - *explode off the surface!*

#ZLOIL1 \$39.95

1 Gallon - Treats 1 55 Gallon Drum of Detergent



# 'Two-Step' Truck Washing Manual is on our Web Site

For Trucks With Polished Aluminum Tanks

## NEVER DULL

55 GALLONS  
\$99.95

Specifically formulated for  
**Vehicles with Polished Aluminum Tanks,  
Imron Paint & Expensive Lettering.**

Never Dull is the preferred product for Vehicles that are, without question, products of an image conscious customer. A lot of time and expense goes into the production of such vehicles. Imron paint itself is very expensive as is the lettering and graphics that present the company's position in the marketplace. With all this in mind, however, nothing, absolutely nothing will get a fleet owner more upset or irritated than when you 'dull' their polished aluminum tanks.

When used according to our recommendations Never Dull is the perfect cold water product that has a unique blend of citrus solvents, surfactants & chelators that we've designed specifically for those trucks that need a product 'tuff' enough to remove carbonaceous pollutants such as grease and fuel over-spill as well as general fallout pollutants, yet gentle enough to clean tanks and never leave them looking dull.

Along with these special blends, Never Dull also has a 'double dose' of Speed -X 777 which keeps the pollutant in solution not allowing it to redeposit itself elsewhere on the surface prior to rinsing. This product is recommended to be used with cold water equipment. The reasoning behind this is because heat generates alkalinity and since Never Dull has a specific balancing of "builder to surfactant" the introduction of heat (hot water) makes it's design both unpredictable and uncontrollable.

In order to avoid 'alkaline shock' remember to cool down the surface prior to product application.

Never Dull is the perfect blend for those 'perfect vehicle finishes.'

5 GAL	#ND5	\$15.00
20 GAL	#ND20	\$45.00
55 GAL	#ND55	\$99.95

Truck Wash With Extra Carbon Release Activators

## RELEASE

55 GALLONS  
\$99.95

**Non-Caustic formula with 'High yield'  
Carbon Release Solvents & Gloss Enhancers**

Release is a high solvent, medium duty vehicle detergent for finer finishes than typically found on 'over the road' Tractors, Trailers & Straight Trucks. This product would be your first choice for vehicles that are washed weekly or every other week. Vehicles such as package delivery, school buses, airport shuttle vehicles that do not see heavy road use but are exposed to carbonaceous pollutants typically found in 'close quarter' operation would be good candidates for Release.

Companies whose vehicles are presently being cleaned with the Release formula are Hertz, UPS, FEDX, DHL and New York Airports not to mention thousands of School Buses. This product was developed while cleaning Connecticut Natural Gas vehicles in the 1980's and have been an industry favorite ever since.

Release is a non-caustic detergent concentrate that contains Gloss Enhancing additives that will help to keep vehicles looking good longer. This product will not harm delicate graphics typically found on such vehicles.

Release exhibits excellent wetting, chelating, rinsing and emulsification properties. Its ability to hold pollutants in suspension during the wash process and not allowing them to be redeposited makes it an ideal product when using cold or hot water systems. The unique 'grease release' activator in RELEASE quickly removes oil/grease pollutants from the substrate.

Release comes packaged in a two-part system. One part is approximately forty pounds of Release Base Product & the second part is one gallon of Carbon Release Activator. When mixed they make 55 gallons of a super concentrate with a very long shelf life.

5 GAL	#REL5	\$15.00
20 GAL	#REL20	\$45.00
55 GAL	#REL55	\$99.95

BLEACH STABLE - EMULSIFYING - FOAM GENERATOR  
with **AMMONYX® LO**

## LAUROX LO

275 GALLON  
TREATMENT  
\$79.95

**FUNCTIONAL PROPERTIES**

- BLEACH STABLE • ACID STABLE
- FOAM ENHANCER • EMULSIFIER
- FOAM STABILIZER • WETTING AGENT
- VISCOSITY BUILDER

LAUROX LO is a unique blend of AMMONYX® LO, solvents, water softeners and quick rinse additives.

With the addition of LAUROX LO to bleach, detergent or acids you can expect a quick rinsing thick foam with dramatically enhanced cleaning characteristics.

Add to product in levels from 3% to 10% by weight.

Treats:

55 GAL	#LA1.0	\$20.00
138 GAL	#LA2.5	\$40.00
275 GAL	#LA5.0	\$79.95

Available in a  
55 Gallon Drum  
\$879.95  
Treats:  
3,000 GALLONS  
#LA55

CLEANER AND BONDING AGENT FOR PAINTERS

## PREPEZZ

20 GALLONS  
\$45.00

**PRE-PAINT SURFACE PREP WITH PAINT BONDING AGENTS**

This non-caustic, specialty solvent based pre-paint prep product has been specifically formulated to safely remove surface oxidation, mildew and general fallout pollutants prior to painting while leaving behind a unique 'paint to surface' bonding environment.

When used properly PrepEZZ will insure that your finished product will last many years longer than what you would normally expect based on paint manufacturers claims. Our unique SuperFlo Polymer Additive, an EnviroSpec exclusive, charges the surface in such a manner that 'locks down' paint adhesion. Used properly the professional painting contractor can be assured that they will never be called back to the job site because the paint is "lifting" or "flaking".

PREPEZZ is sold in a 20 gallon powdered kit form that can be easily dissolved into a solution when needed.

PREPEZZ can be used with hot or cold pressure washers and does not contain harmful caustics or bleach.

#ZPPREP20

This 20 lb. Kit makes 20 Gallons of Concentrate

The Industry's Only 'FILM FREE' Truck Wash

# BOND BREAKER

55 GALLONS  
\$160.00

Contains **STATiX™**

**An exclusive product of EnviroSpec specifically formulated to eliminate 'STATIC CLING' ON VEHICLE SURFACES**

Bond Breaker is the most incredible product of its kind in the industry. Never has anyone been able to remove as much of the film caused by electromagnetic bonding of particles which results as the vehicle cuts it's way through the wind.

Typically this attempt is performed through the use of caustics such as Sodium or Potassium Hydroxides which are typically found in the paint stripping or exhaust hood cleaning industries. These products should never be utilized to clean painted vehicles. Yes, when applied the dirt and debris starts to roll off the surface but behind that dirt is a microscopic layer of the painted surface coming off with it. As the process continues the vehicle surfaces become dull.

Bond Breaker utilizes a unique blend of products to break the magnetic field which holds the film particles on the surface. Given the best of all the elements, soft water, ambient temperatures and cleaning methods, Bond Breaker will remove 99% of all film from the surface. Worst case scenario you can expect 95%-97% removal.

Our development model for Bond Breaker was as follows:

- 1) It had to have an extremely quick reaction time yet Safe to use.
- 2) It had to dissolve grease and carbon on contact with minimum dwell time
- 3) It had to produce a minimum of 92% film free surface.
- 4) It had to have exceptional rinsing characteristics.

**Bond Breaker** is not for everyone. It is an expensive product to formulate and stabilize. It is aimed at a unique market that demands the very best and expects it to perform accordingly.

5 GAL #BB5 \$20.00  
 20 GAL #BB20 \$60.00  
 55 GAL #BB55 \$160.00

House Wash with Solvents & Mildew Release Agents

# LIMONENE

55 GALLONS  
\$99.95

Contains Pure d'Limonene Solvent

**Exterior House Wash Orange Peel Solvents and High Yield Gloss Enhancers**



In recent years the evolution of the environment conscious homeowners are becoming much more educated in the field of exterior house washing. They are saying 'no-more' to the contractors who are using the unfriendly bleach that has been so popular for so long simply because it is inexpensive to purchase and, until now, there have been few alternatives for removing mold and mildew.

The solvency in Limonene originates from citrus by-products such as orange and lime peels. These solvents, coupled with specific pH balanced surfactants and builders, provide the contractor with an excellent product that quickly removes carbonaceous pollutants such as oil and grease and other fallout pollutants commonly found in the house washing industry. Pollutants such as gutter streaks, mold/mildew, etc. For the first time ever they are experiencing safe and effective surface chemistry that deals with wood, aluminum and vinyl siding and the pollutants common to those surfaces.

Limonene has excellent hydrotoping characteristics through the use of a unique dispersant complex which is not commonly found in detergent chemistry. This complex, known as SuperFlo Polymer, has been developed by EnviroSpec and is found throughout our detergent formulary because of its tremendous ability to add horsepower to virtually every type of alkali detergent products while remaining much more gentle than the alternatives. You will find that Limonene has superior rinsing qualities in both hot and cold water environments which results in cleaning faster and safer.

5 GAL #LIM5 \$15.00  
 20 GAL #LIM20 \$45.00  
 55 GAL #LIM55 \$99.95

LOADED WITH GLOSS ENHANCERS

# FOAM & SHINE

55 GALLONS  
\$99.95

High Foaming Car, Truck & House Wash

**SINGLE PASS CLEANING! INCREDIBLY FAST RINSING! GREAT SHINE!  
HIGH FOAM CLEANING! SOLVENT FREE!**

*That is what the 'Foam-N-Shine' Formula is all about!*

Using the finest builders in the industry and adding in specific water softening and foaming additives plus a blend of unique 'chelating agents' which 'tie up' the metallic ions in water has resulted in that 'always looked for' but 'seldom found' black magic formula that we now call...

## FOAM'N-SHINE

FOAM-N-SHINE exhibits excellent wetting, chelating, rinsing and emulsification properties due to its high concentration of our SuperFlo Polymer Complex System. This exotic complex is formulated from a variety of unique dispersants, hydrotopes, and surfactants which are not commonly found in detergent formulations. With this 'double dose' of SuperFlo Polymer you can expect exceptional brilliance on most surfaces.

FOAM-N-SHINE dramatically reduces surface tension so pollutants 'roll-off' the surface with ease without having to brush. With special wetting agents you will find that FOAM-N-SHINE keeps the surface wetter longer allowing the contractor more flexibility in washing larger areas without having to worry about the surface drying before rinsing. FOAM-N-SHINE works extremely well with cold water or hot water equipment.

5 GAL #FS5 \$15.00  
 20 GAL #FS20 \$45.00  
 55 GAL #FS55 \$99.95



# Exhaust Hood Cleaning Manual is on our Web Site

MAKE YOUR OWN CAUSTIC EXHAUST HOOD CLEANER

## PERFORMANCE BUILDER

137 GALLON  
TREATMENT  
**\$79.95**

**WAIT! DON'T BUY ANY MORE CAUSTIC HOOD CLEANERS**

*if you do you are wasting even more money!*

Personally speaking I think one of the biggest 'scams' perpetrated on the Professional Mobile Wash Industry is trying to make them think that there is a lot of 'rocket science' that goes into producing high performance, caustic exhaust hood cleaners. There isn't and if you insist on purchasing those type of products - well then - you are just wasting a lot of money because anyone can make them.

Simply purchase a drum of 85% Potassium Hydroxide and add one gallon of

### PERFORMANCE BUILDER PLUS

Sodium Hydroxide and Potassium Hydroxide Exhaust Hood Cleaners and Paint Strippers (same thing) are nothing but 1 gallon of surfactant added to the drum and stirred in. Nothing more - *nothing less*. The secret is this - because of the aggressiveness of these two raw materials there are only a couple of surfactants that are stable in the solution for any period of time and they are not cheap. Because of the cost of this family of surfactants many manufacturers rely on a nine mole surfactant such as that found in typical detergents and slap a label on it and out the door it goes. The trouble here is that by the time you get the product the surfactant has been overwhelmed by the hydroxide to a point where it has exhausted it's ability to perform. Performance Builder Plus is a blend of high yield, caustic stable surfactants & emulsifiers that will hold up indefinitely and help to 'crank up' the horsepower of the raw material.

Next time you decide to buy a caustic cleaner order up a gallon of Performance Builder Plus. Then look in your yellow pages for your local chemical supplier. If you can't find one call Univar at 800-233-0633 or <http://www.univarusa.com> or Brentag Mid South at 800-289-4020 or <http://www.pbschemical.com> for their location nearest you.

A premium caustic exhaust hood cleaner would be one where 50 pounds of sodium hydroxide beads are mixed with 55 gallons of water along with one gallon of Performance Builder Plus. Exercise caution when mixing sodium hydroxide beads with water. Add very slowly otherwise there can be a violent reaction where the product will blow back on you. After the beads have been added stir in the Performance Builder Plus. If you use Potassium Hydroxide you will purchase that in a 85% liquid form. Typically a manufacturer will make 4 drums out of 1 drum of the 85% solution. In this case you will need 4 gallons of Performance Builder Plus. EXERCISE CAUTION when working with any chemical product. Read and understand the MSDS and all safety information about the products being handled. Wear protective clothing and safety glasses. Do not allow any unprotected person or animal around the mixing area. Clean up when done.

#ZLPBC - This 2.5 Gallon Kit will treat 137 Gallons of Caustic - 3,000 Gallon Kits also available (55 Gallon Drum) - CALL

NEED TO MAKE A FOAMING DETERGENT?

## KLINGON FOAMER

Thickens  
75 GALLONS  
**\$24.95**

**WANT IT TO LAY ON THE SURFACE LONGER?**

.40 Pounds of KLINGON is all you will need to turn a 5 gallon pail of detergent or exhaust hood cleaner into a rich, thick Foamer!

Need a product that 'clings' to the surface? Or maybe a product that will provide you with that added dwell time that many projects require.

KLINGON is a non-acidic blend of natural thickeners and foamers that work in both alkalis as well as some acids such as many of those found in the aluminum brightening industry. Call for acid compatibility.

This is especially useful in the exhaust hood cleaning industry where product to surface dwell time is crucial.

Most thickeners on the market are formulated by introducing an acid into an alkali to thicken the product. When this happens product neutralization occurs. This leaves the operator with a thick product but one with dramatically reduced performance characteristics.

KLINGON can easily be adjusted to produce a slightly thickened product or a 'wall paper-paste' type product should you require a brush or roll-on paint stripper.

#ZPKL5- This 5 lbs thickens up to 75 gallons of product

QUICK RINSE ADDITIVE

## SPEED-X-777

275 GALLON  
TREATMENT  
**\$49.95**

**Not making as much money  
as you thought you would?**

Have you stopped to consider that 70% of your overall cleaning time is lost in the RINSING rather than WASHING?

Don't believe it? The next time you go to the job site time yourself. How long does it take to apply the soap and how long does it take to make absolutely sure that all the "soap" is rinsed free? *You are in for a shock!*

**Cut your WASH TIME as much as 70% with Speed-X-777**

**Plus You'll Save that Precious Water!**

**Add 1 Gallon to 55 Gallons of detergent.**

(enough for 275 Gallons)

#ZLSPE5

This 5 Gallon Container Treats 275 Gallons of Concentrate

Concrete Cleaner & Brightener

The Only Non-Caustic Exhaust Hood Cleaner

# POWER STROKE

55 GALLONS  
\$199.95

# HOOD PRO

Specifically Formulated For  
FLAT SURFACE CONCRETE CLEANING

"Power Stroke" has successfully replaced the harsh caustics that have been being used for years. The science behind Power Stroke has made it the Professionals First Choice.

Contains:

## CONCRETE BRIGHTENING AGENTS

*Power Stroke is the highest non-caustic detergent concentration available in the industry.*

Power Stroke has been specifically formulated for heavy-duty oil/grease removal for untreated concrete. Unlike the caustics typically used in this industry Power Stroke is much more user and surface friendly when it comes to over spray.

You will find Power Stroke cleans much 'quicker' than caustics and acids due to it's excellent wetting, rinsing and emulsification properties and SuperFlo Polymer Complex System.

The general rule of thumb in detergent formulation is as follows: Approximately 1 gallon of water will hold approximately 1 pound of powder before separation begins. If your product begins to separate using this calculation, more often than not, your product has been camouflaged with what is known in our industry as fillers. Fillers provide little to no value to the products integrity. They are used primarily to add weight and increase the bottom line profit for the manufacturer. A typical filler would be Soda Ash. Using the 1 pound per 1 gallon rule you can see the potency of Power Stroke when you consider that we are able to thoroughly dissolve up to 2.5 pounds of Power Stroke into 1 gallon of water without separation. To our knowledge - no other company can make this claim. The advantage of these concentration levels are two fold: 1) the contractor is now able to clean substrates that normally require the use of caustic cleaners and 2) work faster and safer which increases your bottom line.

5 GAL	#PS5	\$25.00
20 GAL	#PS20	\$75.00
55 GAL	#PF55	\$199.95

Specifically Formulated For  
RESTAURANT EXHAUST HOOD CLEANER

10 years ago they were sceptical. Today more contractors are using Hood Pro as their First Choice Cleaner over the strongest Caustics on the market!

Until now Professionals have always had to rely on corrosives for the real tough hood cleaning jobs but not anymore! Hood Pro has revolutionized the industry by providing the contractor with a product that cleans as quick and effective as the 'hottest' hydroxide products in the industry while leaving him completely 'scare free' and with hair still on his arms when the job is complete. Only a Professional Exhaust Hood Contractor can fully appreciate that statement.

EnviroSpec's HOOD PRO product is the non-caustic workhorse of the professional exhaust hood cleaning industry. Known for it's consistent high performance, this powerful grease dissolving formula is being used more and more by the professionals who know and understand the disadvantages of using sodium or potassium hydroxide products. The "power" from Hood-Pro comes mainly from a wide variety of special 'ion' charged surfactants not commonly found in the detergent formulary industry. Coupled with a unique "builder" base, HOOD-PRO exhibits unbelievable pH stability and excellent foaming characteristics.

HOOD PRO offers excellent and economical grease dissolving, foaming, wetting, emulsification and biodegradability needed for today's specialized contractor. HOOD PRO is 100% active and highly concentrated. For example; the 'hottest' hydroxide products consist mainly of 50 pounds of powder to 50 gallons of water. The finished HOOD-PRO product will yield 55 gallons which is compounded from 80 pounds of the finest builders and performance driven surfactants in the industry

HOOD PRO will respond to your most difficult cleaning project with ease and provide you with an environment which is much safer to humans and less damaging to the surface.

5 GAL	#HP5	\$25.00
20 GAL	#HP20	\$75.00
55 GAL	#HP55	\$199.95

## Heavy Duty Detergent with Gloss Enhancers

55 GALLONS  
\$99.95

# BIO-GREEN



Until now - most 'so called' environment friendly cleaners have been little more than 'watered down' products that have been sold under another name.

Choosing environmentally friendly cleaning products and eliminating toxic ones has always been what EnviroSpec is all about and Bio-Green is the latest addition to our arsenal of environment friendly products.

Bio-Green, a variation of the Limonene family, is the answer to everyone's concerns about Earth Friendly products that really can clean.

Bio-Green is truly a workhorse in the industrial and institutional detergent industry. Known for consistency, EnviroSpec, has developed this product to be the answer to all of the concerns in the vehicle cleaning and house washing industry as well as other projects requiring special surface active properties.

Bio-Green offers excellent and detergency, foaming, wetting, emulsification and biodegradability needed for today's specialized high performance cleaning products. It has excellent foaming characteristics which will provide the user with the necessary visual requirements to determine concentration levels on the surface being cleaned. Yes, Bio-Green can respond to your toughest needs, whether it's a medium duty truck or house wash job or a 'down and dirty' forklift with years of grease and grime. And it can do all this and still be gentle on the world we live in.

5 GAL	#BG5	\$15.00
20 GAL	#BG20	\$45.00
55 GAL	#BG55	\$99.95

On this page we pay the freight on \$50.00 Web Orders or \$200.00 Call-in Orders



# Deck Restoration Manual is on our Web Site

Sodium Hydroxide FREE Deck & Shake Stripper

## STRIP-T-EASE

55 GALLONS  
\$99.95

**The Safest Deck Stripper in the Industry**

Simply spray 'STRIP-T-ease' on and let it sit for 15 minutes and power wash the stain away.

'STRIP-T-ease' contains a unique blend of surfactants and emulsifying solvents that attack and breakdown the stain allowing for a fast attack and flush product.

'STRIP-T-ease' is packaged in a 55 gallon drum pack which consist of 50 pounds of a powder and solvent blend. Simply add your own water to produce a product that is superior and safer than anything you have ever used.

5 GAL #STR5 \$15.00  
20 GAL #STR20 \$45.00  
55 GAL #STR55 \$99.95

Removes Rust Stains from Concrete

## RUST-A-WAY

55 GALLONS  
\$89.95

Specifically formulated  
to Remove Well Water Rust Stains

**Spray-on! Rinse-off! No Scrubbing Necessary!**

**If you work or live in Florida there are two things you must have...  
...a bathing suit and a box of Rust-A-Way!**

RUST-A-WAY crystals are a unique blend of mild acids and surfactants which remove well-water rust stains from concrete surfaces.

*Spray it on - have a cup of coffee and rinse off.*

Not for use on Brick containing iron oxide pigments.

Run a test pattern in an inconspicuous area if you are not sure.

5 GAL #RUS5 \$19.00  
20 GAL #RUS20 \$40.00  
55 GAL #RUS55 \$89.95

Oxygen Deck & Shake Cleaner

## RESTORE

55 GALLONS  
\$79.95

**Simply Put - Awesome!**

**BRINGS OLD WOOD BACK TO NEW**

Cedar Shakes & Unpainted Wood Surfaces such as Decks - Stripping Antique Furniture - Cleaning Tile Grout - Laundry Presoak & Bleach Replacement - Carpet Cleaning ... *you just won't find anything better than RESTORE!*

For Cedar Shakes and unpainted Wood Decks simply spray RESTORE on, wait 20 to 30 minutes, and rinse off. You will not believe your eyes! No more harsh bleach or surface and vegetation aggressive chemicals. Totally removes black mold and mildew build-up on shakes, regardless of how long it has been there.

RESTORE works by means of oxygenation and should not be mixed with water until the operator is ready to perform the job. Once RESTORE is in solution, the operator will have approximately 1-2 hours before the product has exhausted itself. Mix up enough so that you will be able to get the product on the surface within this time. Mix approximately 1/2 to 1 pound of RESTORE into 1 gallon of water and stir several turns. Complete solubility is not necessary since RESTORE will go into solution on it's own through the oxygenation process. Using a ShurFlo Pump place the pick-up line in the solution and spray product directly onto the surface. When product has removed pollutant, rinse with low pressure, 500 - 1000 PSI is all that is required. When using this product on pressure treated wood we recommend the 1/2 lb to 1 gallon of water ratio and rinsing with no more than 500 PSI. Higher dilutions and pressures will cause the surface to 'fuzz' up. When this happens it is generally a temporary situation that will correct itself in a couple of days. Do not use a pump-up sprayer to apply Restore since this product builds pressure when added to water and will over pressurize the sprayer which could result in an injury should the sprayer erupt.

This product will provide unbelievable results. You will be able to produce twice the results in 1/3 the time and with little to no mess. You'll never use harsh chlorine cleaners or solvent based strippers again.

5 GAL #RES5 \$20.00  
20 GAL #RES20 \$45.00  
55 GAL #RES55 \$79.95

Neutralizes, Brightens & Repairs Unpainted Wood

## DECK & SHAKE BRIGHTENER

55 GALLONS  
\$79.95

**High pH 'detergent beds' especially sodium or potassium hydroxide, shorten the life of wood.**

The Deck Restoration Industry has grown considerably in recent years. As is the case when most great ideas are conceived - experts seem to blossom overnight as they have done here. This is not always a good thing.

In the Professional Mobile Wash Industry contractors quite often find themselves in the 'clutches' of many companies with so-called 'revolutionary' cleaning products that are merely extremely high pH detergents of which most are either sodium or potassium hydroxide based. These are great products but not for this industry. The hydroxide family of products are extremely effective in the drain cleaning and exhaust hood cleaning industries but certainly not wood cleaning. When used for wood cleaning they immediately start breaking down wood fibers.

More often than not this idea of using an excessively strong alkali detergent 'bed' has been introduced to kill mold and mildew. We have a product, RESTORE, that will do this without harming the wood but even if RESTORE is not the product of choice a very diluted solution of bleach would be a much better choice than high pH detergents.

Deck & Shake Brightener is a product that will do 2 things. First it will brighten weathered wood and revive it's natural color. For years this product has been a favorite among furniture craftsman who occasionally find themselves in a situation where a dark or stained spot needs to be blended back in to match the rest of the wood. Second it can be used as the necessary "bandage" when contractors insist on using these strong detergents and the wood has darkened as a result. Or they have to follow behind another contractor who has darkened the wood and doesn't know how to fix it. Deck & Shake Brightener quickly starts reversing this action upon contact. Typically, the darkened surface will be back to normal in 1-4 days.

5 GAL #DSB5 \$19.00  
20 GAL #DSB20 \$45.00  
55 GAL #DSB55 \$79.95

On this page we pay the freight on \$50.00 Web Orders or \$200.00 Call-in Orders

For Gutter Streaks & Heavy Oxidation

# RIPPER

55 GALLONS  
\$150.00

**Removes those 'nasty' Black Streaks & Heavy Surface Oxidation on Gutters**

Our House Wash Collection offers a rich assortment of job matched cleaning products that are uniquely EnviroSpec. RIPPER is just one in that collection that has been making the Exterior House Washing Professional's job so much easier for so many years. To professionals, the real beauty to any of the EnviroSpec performance products is how fast, how effective and how safe they are to use.

RIPPER, developed specifically for gutter streaks & oxidation removal, utilizes several blends of high-performance solvents and specially blended surfactants to deliver optimum efficiency. Knowing that no two gutters will clean alike, EnviroSpec has incorporated into RIPPER a variety of solvent blends that will work independently on the specific pollutant that has created the streak. One of these unique solvents will attack and eliminate the problem.

Of all the questions that have been thrown at us about house washing - the question of how to safely remove gutter streaks is by far the most frequent. We know that solvents are the only products that will safely remove gutter streaks and RIPPER has more than twice the solvent content than most cleaning products in our industry.

After it's introduction into the industry in 1987 RIPPER soon became the envy of many companies who are in the business of manufacturing products for such a demanding industry. Many of those companies sell sodium or potassium hydroxide base products to tackle the gutter streak problem and the unsuspecting contractor buys them not knowing that what they are actually buying are paint strippers. RIPPER is a more effective and much safer way to eliminate the gutter streak & oxidation problem.

5 GAL #RIP5 \$20.00  
20 GAL #RIP20 \$60.00  
55 GAL #RIP55 \$150.00

Contains Silicone for Surface Luster

# PREMIER

55 GALLONS  
\$89.95

**Specifically formulated for Colored Siding with Heavy Oxidation**

After cleaning - Premier leaves a SILICONE MEMBRANE on the surface which is designed to retard the formation of mildew and to keep general 'fall-out' pollutants from adhering to the surface..

Premier would also be your first choice for cleaning new homes in a housing development where the pollutant being cleaned is primarily mildew and general 'fall-out' pollutants. This type of cleaning does not require the solvent but only mildew release agents and gloss enhancing additives. Premier would also be a great choice for houses or mobile homes that are cleaned annually.

Premier takes a bow for impressive performance in providing a thorough wash/rinse cycle while remaining gentle on new aluminum, vinyl and wood siding.

Premier is a unique blend of specialty surfactants and alkalis specifically formulated for the Professional Exterior House Washing Industry. It acts by first wetting and chelating pollutants and then holding them in suspension until the surface is thoroughly rinsed.

Premier is less aggressive on surface and vegetation than typical cleaners used in this field but will achieve superior cleaning results.

Premier is ideally suited for both a hot and cold water pressure washers. By chelating of both calcium and iron in water and a unique water softening additive Premier will provide 'spot free' rinsing when used in accordance with the manufacturers instructions.

5 GAL #PRE5 \$15.00  
20 GAL #PRE20 \$40.00  
55 GAL #PRE55 \$89.95

## Mildew Retardant & Surface Protector with Gloss Enhancers

# PLEX-MASTER

Makes  
55 GALLONS  
\$79.95

**Specifically formulated for the Exterior House Washing Industry**

Plex-Master is a blend of silicone & silicone hardener, polymer and mildew retardant that will enhance the appearance of Vinyl and Aluminum Siding, Painted Wood and Metal surfaces after cleaning. Plex-Master is also an excellent product that will eliminate or substantially reduce the reformation of mold and mildew on all surfaces.

Plex-Master provides a distinctive edge that will separate the Professional Contract Cleaner from the "Splash 'N Dash" house washer. For just pennies per job the contract cleaner can provide the homeowner with a 'cleaner clean' and a 'brighter shine' that will last much longer than that of their closest competitor.

When you explain the advantages of using environment friendly products that will leave the soil exactly the way you found it and the added benefit of the Plex-Master application you have virtually left your competitors in the 'dust (dirt)'. With the addition of this product to your sales presentation you will be washing houses from \$400.00 and up even though your competitor quoted them for \$79.95. This is a fact that has been proven time and time again.

Mildew, which will form on virtually anything, will be much easier to remove when the surface has been coated with Plex-Master. In most cases the homeowner will be able to keep the surface looking 'alive' and free of mildew with an occasional rinse down using a standard garden hose. Another great feature of Plex-Master is that once applied and rinsed before it has been allowed to dry, the windows will be 'squeaky' clean. Our 2.5 gallon container makes 28 gallons & our 5 gallon pail makes 55 gallons. Apply & rinse in 15 minutes.

28 GAL #PLE28 \$40.00  
55 GAL #PLE55 \$79.95



# NEW FOR 2011 - SPECIALTY ACID CLEANERS

## PROFESSIONAL ACID CLEANERS

### ACID PREP 4410

55 Gal. \$460.17

A true HF #1 detergent used in a two-step process to pre-treat road film, diesel soot and aluminum surfaces. Designed to use in high-pressure two-step systems with a dilution ratio of 25:1. Road film and grime as well as diesel soot are removed without brushing when used in conjunction with Largo #2 type detergent. #1 Acid Prep quickly brightens aluminum surfaces, neutralizes completely with Largo #2 product and can be used with hot or cold water at high or low pressure.

### ACID PREP 4411

55 Gal. \$531.55

A phosphoric/citric #1 detergent used in the two-step process to pre-treat road film, bugs, diesel soot and clean aluminum on vehicle surfaces. #1A Acid Prep is completely safe on all surfaces. #1A Acid Prep was designed to use in high-pressure two step systems with a dilution ratio of 25:1. When used in conjunction with any Largo #2 type detergent, road film, bugs, and diesel soot are removed without brushing. #1A Prep brightens aluminum surfaces, neutralizes completely with Largo #2 product and can be used with hot or cold water at high or low pressure.

### SALT BUSTER

55 Gal. \$446.97

Salt Buster safely removes and neutralizes road salt from snow plows, loaders, graders, dump trucks, transit vehicles, rolling stock, buses, commercial and municipal vehicles and equipment. Salt Buster may be applied with low-pressure applicators on pressure washer, undercarriage applicators or foaming device. Easy and simple to use.

### ABX 4450

55 Gal. \$492.29

ABX is a specially formulated blend of acids, wetting agents, inhibitors, and chelating agents designed to rapidly remove salt, stains, soot and contaminants and brightens aluminum surfaces instantly. ABX rinses freely and dries streak-free. ABX may be used with hot or cold-water application, with a dilution ratio of 50:1. ABX is an industrial-strength product and must be properly used by trained personnel. Apply through pressure washer with a pump saving down stream injector, or use pump-up sprayer, foaming device or through acid arches. Use protective clothing and face shields at all times when using this product. Uses: Aluminum trailers, painted trailers, tankers, reefers, dump beds, fuel tanks, pontoons, and more.

### ABX 4450 HIGH FOAM

55 Gal. \$534.58

ABX HF is the same as ABX 4450 with high foam.

### ABX EXTRA

55 Gal. \$644.87

ABX Extra is a Highly Concentrated Hydrofluoric Acid Solution for extra heavy duty brightening of aluminum tanks, vans, reefers, livestock hauler and panels. Extra care must be taken when using this concentrated product. Only well trained and well-protected personnel should use this product. Hydrofluoric Acid solutions can be very dangerous and deadly if contact is made in concentrated form to human tissue. Please refer to the MSDS prior to considering this product and understand how this product is intended to be diluted and used in the cleaning process.

### TRAIL BRITE

55 Gal. \$499.82

An acidic blend enhanced with special wetting agents and emulsifiers used in two-step process, Trail Brite rapidly removes road film, bugs and diesel soot and cleans aluminum surfaces on vehicles without brushing when used in conjunction with any Largo #2 type of detergents. Quickly brightens aluminum. Designed to use in high-pressure systems with a dilution ratio of 25:1. Trail Brite neutralizes completely with our #2 product. Uses: Aluminum trailers, painted trailers, tankers, reefers, dump beds, fuel tanks, pontoons, and more.

### MIRROR BRITE

55 Gal. \$484.92

Mirror Brite Polished Aluminum Maintainer is an exceptional product designed to "maintain" that polished aluminum appearance on wheels, fuel tanks, tank trucks, feed trucks and fuel trucks. Mirror Bright is a non-etching cleaner and brightener that with continued use maintains the appearance of polished aluminum surfaces. Does not turn the aluminum surface "white, satin, or dull" like Aluminum Brighteners will. Does not contain hydrofluoric acid, ammonium bifluoride, hydrochloric or sulfuric acid. It may be used in hot or cold water systems with either low or high-pressure spray. We find that it works best when used in our Two-Step Systems along with our 4425 Super Clean Truck Wash. It may be used on most surfaces not harmed by water.

### STABRITE

55 Gal. \$443.57

Sta Brite Aluminum Brightener is a non-hydrofluoric (HF) acid brightener designed for use on polished aluminum tanks and trailer stock. Completely safe on glass, non-dulling, and will not "milk" mirror-polished aluminum surfaces. Advantages: Highly concentrated for economical use. Free-rinsing and non-streaking. Safe on environment. Safe for personnel.

### CONCRETE REMOVER

55 Gal. \$427.12

Concrete Remover is a powerful extra heavy-duty concrete remover designed for thorough removal of concrete (less than 1/16" thick) from most ferrous metals. It is intended for use on ready mix trucks, concrete mixers, concrete forms and other equipment where concrete accumulation occur. Concrete Remover is inhibited to protect the metal substrate, works fast, is economical and is harmless to good paint.

### CONCRETE TRUCK ACID WASH

55 Gal. \$736.53

Concrete Truck Wash is a blended acidic detergent for daily washing concrete truck fenders, slides, drum and wheel wells on concrete carriers. Removes concrete film and residue while providing excellent detergency to quickly clean away stubborn soils, oil, grease and grime. May be brushed or sprayed and hosed off with manual or high-pressure water. Does not contain muriatic acid. Works well in brick and masonry cleanup.

# ENVIROSPEC LIQUID CONCENTRATED DETERGENTS

The following are liquid versions of several of our detergent products that until now you have only been able to purchase in Drum-Kit versions. You will notice that all - have 'extra' solvents, rinse-aids, surfactants and foamers. We are able to do this because we have the 'high-shear' equipment that will blend these super concentrated products in such a manner where minimum to zero 'fall-out' will occur. You also will find that our 'pure-water-plus' blending process will make an already 'great' and 'almost perfect' product - PERFECT!

Prodigy Double & Tripple Strength is, by far, the highest non-caustic detergent concentrations available in the industry. Prodigy exhibits excellent wetting, chelating, rinsing, and emulsification properties due to its high concentration of our SuperFlo Polymer Complex System. This exotic complex is formulated from a variety of unique dispersants, hydrotopes, and surfactants, which are not commonly found in detergent formulations.

The general rule of thumb in detergent formulation is as follows: Approximately 1 gallon of water will hold approximately 1 pound of powder before separation begins. If your product begins to separate using this method, more often than not, your product has been camouflaged with "fillers". Fillers are used primarily to add weight and increase the bottom line profit for the manufacturer. Using the 1 pound per 1 gallon rule, you can see the potency of Prodigy when you consider that we are able to thoroughly dissolve up to 2.3 pounds of Prodigy into 1 gallon of water without separation.

**These versions of Prodigy also includes our Quick Rinse Aid - Speed-X-777 & extra Foamers**

For more information about this product read the description under the Powder Drum Pak version.

**PRODIGY DS  
DOUBLE  
STRENGTH**  
#ZLPRO-DS  
55 Gal. \$462.00

**PRODIGY TS  
TRIPPLE  
STRENGTH**  
#ZLPRO-TS  
55 Gal. \$636.00

Bond Breaker is the most incredible product of its kind in the industry. Never has anyone been able to remove as much of the film caused by electromagnetic bonding of particles which results as the vehicle cuts it's way through the wind.

Typically this attempt is performed through the use of caustics such as Sodium or Potassium Hydroxides which are typically found in the paint stripping or exhaust hood cleaning industries. These products should never be utilized to clean painted vehicles.

**This liquid version of Bond Breaker also includes our Quick Rinse Aid - Speed-X-777 + Extra Solvents**

For more information about this product read the description under the Powder Drum Pak version.

**BOND  
BREAKER**  
#ZLBON-DS  
55 Gal. \$447.00

Mr. Muscle Liquid is a 55 gallon drum of Prodigy, the industry's #1 Selling Tractor/Trailer Wash, plus 4 gallons (1.5 gallon more than the powdered version) of solvent/surfactant additive that really cranks up the horsepower and safely cuts through the heavy build-up of carbonaceous pollutants such as the exhaust typically found on over-the-road trailer bodies and 'fifth-wheel grease!'

**This version of Mr. Muscle also includes our Quick Rinse Aid - Speed-X-777**

For more information about this product read the description under the Powder Drum Pak version.

**MR. MUSCLE  
LIQUID**  
55 Gal. \$442.00

EnviroSpec's HOOD PRO product is the non-caustic workhorse of the professional exhaust hood cleaning industry. Known for it's consistent high performance, this powerful grease dissolving formula is being used more and more by the professionals who know and understand the disadvantages of using sodium or potassium hydroxide products. The "power" from Hood-Pro comes mainly from a wide variety of special 'ion' charged surfactants not commonly found in the detergent formulary industry.

**These versions of Hood Pro includes extra foamers and thickeners for the best clinging action in the industry.**

For more information about this product read the description under the Powder Drum Pak version.

**HOOD-PRO  
DOUBLE  
STRENGTH**  
#ZLPRO-DS  
55 Gal. \$535.00

Bio-Green 'LO' is truly a workhorse in the industrial and institutional detergent industry. Known for consistency, EnviroSpec, has developed this product to be the answer to all of the concerns in the vehicle cleaning and house washing industry as well as other projects requiring special surface active properties.

**Bio-Green 'LO' includes a high concentration of AMMONYX® LO Bleach Stable Surfactant**

For more information about this product read the description under the Powder Drum Pak version.

**BIO-GREEN 'LO'**  
#ZLBIGLO  
55 Gal. \$394.00

Emulsifier Plus - is one of the Original House Wash Formulas developed by EnviroSpec. Our dilemma at the onset of its development stages were: we all know bleach works better than anything for killing and cleaning mold & mildew but we also knew that bleach does absolutely nothing about cleaning carbonaceous pollutants such as exhaust carbons, dirt, grease and grime. The task was - how to do both at the same time!

Bleach, for the most part, does not like to be blended with other chemical products and many of the chemical products found in the professional mobile wash industry can create a serious explosive situation when mixed with sodium hypochlorite (bleach). Emulsifier Plus, on the other hand, is the answer to both the safety issue as well as the cleaning problem. These two products work extremely well together when blended and applied in accordance with the EnviroSpec instructions. Have the best of both worlds - Clean and Kill Mold & Mildew plus cleans all the other pollutants that bleach will not touch...

...and do it all in one pass!

**Emulsifier Plus 'LO' is loaded with AMMONYX® LO Bleach Stable Surfactant**

For more information about this product read the description under the Powder Drum Pak version.

**EMULSIFIER  
PLUS-LO  
DOUBLE  
STRENGTH**  
#ZLEMULO  
55 Gal. \$390.00

The above Liquids are manufactured by EnviroSpec & are sold on a U-Pay Freight basis.





As you can see...  
Suzie's Friends is to animals  
much like Disney World is to kids.

'Skipper' (to the left) has his very  
own 'handicap' ramps and ladders  
so he can be a part of all the fun.

*Yes - we spoil our children too.*



As you can see we make absolutely sure  
that our animals are comfortable.



More often than not when someone contacts  
the State of GA inquiring about building an  
animal shelter they tell them to visit Suzie's  
Friends first.

Those who visit find a facility as clean or  
cleaner than most hospitals and a lot more  
fun.





It doesn't get any better for animals than...

Suzie's  
Friends



This 'state of the art' sanctuary consist of 12,000 square feet of living quarters which includes approximately 2000 square feet of beautiful arenas where the cats can come and go as they please.

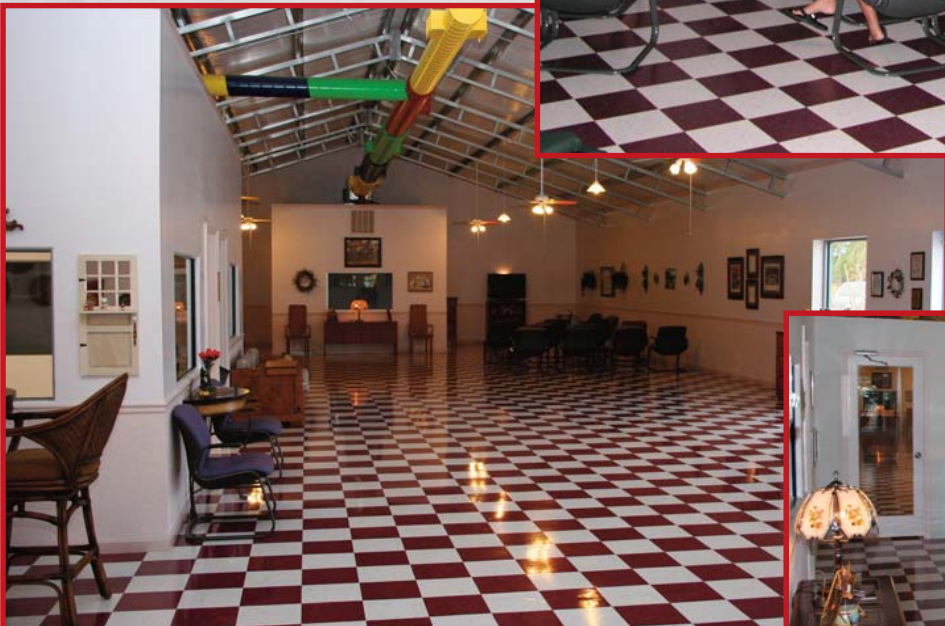

Suzie's Friends is nestled in the small community of Homerville, GA and has visitors from all over the country stopping by to say 'hello.'







# CHARITIES

EnviroSpec donates 100% of the profits from its Chemical & Equipment sales to Animal Charities such as Suzie's Friends Animal Sanctuary, The Humane Society of the United States, ASPCA, Local Animal Shelters, Humane Societies and Rescues in other areas of the country.

Meet Suzie, who inspired John & Shelley Allison to build Suzie's Friends Animal Sanctuary.

This is a 'labor of love' that John & Shelley Allison have committed their lives to in honor of all of Suzie's friends everywhere who are beaten, abused, homeless & hungry.



Suzie

It is through this passion that we are reminded daily of all the animals who walk the highways & by-ways throughout our Nation in search of something to eat, a warm place to sleep or a soothing voice to calm their fears.

And we must never forget the thousands who didn't find anything to eat or when help came - *it came to late.*

The mission of Suzie's Friends is to provide a special no-kill, no-cage sanctuary where the hungry are fed, the homeless are sheltered, and the abused and abandoned are provided care.

Each day over 10,000 HUMANS are born in the United States and each day 100,000 Puppies and Kittens are born and as long as these birth rates exists there will never be enough homes for all the animals.



As a result we force sad men and women to show up every week at animal shelters everywhere with tears in their eyes as they come to end the lives of millions of beautiful, loving animals who's time is up - and this is being done in the greatest and most giving NATION in the world that has yet to come up with anything more humane.

The rest are left to fend for themselves against automobiles, the elements, other animals and cruel humans.

Regardless of their condition every animal we see gets a chance to live and given that chance most will. The pup to the right is named 'Chance' and as horrible as he looks he turned out to be the most beautiful dog.



The only chance they have is if we all SPAY & NEUTER our pets as well as those who are lost or been abandoned and allow them to live out the rest of their lives where they have chosen to call home.

*"The greatness of a Nation and it's moral progress can best be judged by the way in which it's animals are treated." --- Gandhi*

With this incredible thought in mind I can say to you today that we have not treated our animals very well.

But together we can take the first step in helping our animals by reminding everyone that through Spay/Neuter programs we will never

have to kill an unborn kitten or puppy.



At 7 a.m. and 5 p.m. daily we take off to feed 25 colony cats in our neighborhood. They are all Spayed/Neutered & well cared for.

This is Olive Oil (eating) and Gulliver. Gulliver was hit by a car and killed shortly after this picture.

We will always remember and miss him. He was a good boy & great friend.



So, if one litter of kittens goes unborn or one dog is not tied to a tree or shoved in a drum and forgotten or one 'stray' is fed as a result of what we choose to do today then we will have done a good thing for our animals.

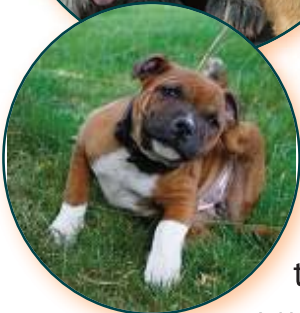

99.5% of the funding that Suzie's Friends receives comes from EnviroSpec but that is not enough. There are no volunteers to help with the heavy workload required to maintain Suzie's Friends. EnviroSpec employees show up early every morning to clean and care for the animals.

We need your help to be able to keep our commitments to animals everywhere a reality. Because we are a no-kill sanctuary it cost hundreds of dollars per animal to make sure they all live a healthy, happy life. A life where some will eventually find loving homes but where most will live out the rest of their life at Suzie's Friends.

Because of you - our customer we are able to give back so much in the form of love & support to the Children & Animal Charities that we serve. Thank you, Shelley & John Allison

Go to <http://www.suziesfriends.org> and see the video of this beautiful facility.





Here is what Suzie's Friends  
is all about...

## Meet Suzie's Friend **Simon**

In October 2007 Simon was hit by a car on Jekyll Island, GA. His eyes had been knocked out of their sockets and, among many other things, he had 4 ribs that had been broken away from his spine.

Simon was on an IV for several days while he was unable to eat. Honestly, most would have given up and put this little fellow out of his misery and pain but we kept looking for the 'wag.'

You see - given a little time a dog will tell you when they can't take any more and it is time for them to let go. The sign we look for at Suzie's Friends is the 'wag' of their tail. It took a while for Simon to decide but on day 5 we visited him and as I touched his head his little tail moved ever so slowly a couple of times. I knew then that he had decided to live.

Suzie's Friends is full of stories just like Simon's. Honestly - they all want to live and will if we give them a chance. We do everything humanly possible to give them that chance but it cost a lot of money.

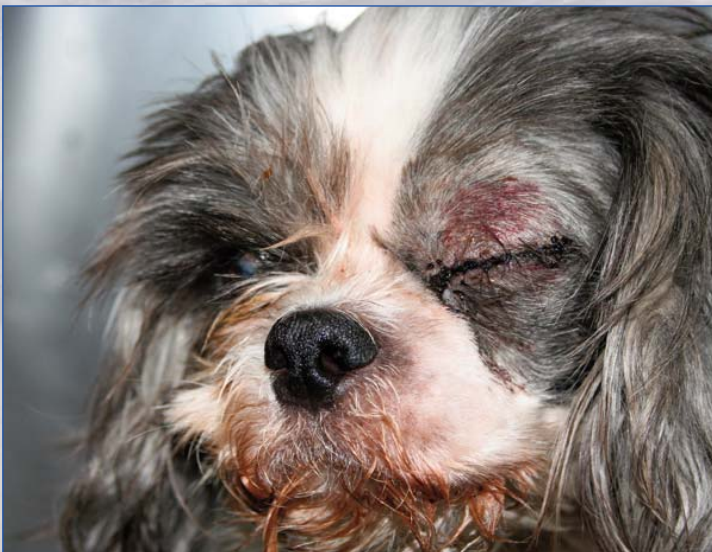

Simon's doctor bills escalated to \$2500.00.

To continue to do the things we do we always need financial help. So - if you have a few bucks you can spare you can help Suzie's little friends find their way through the real tough times and into a loving home. Our promise to them is their time will never be up at Suzie's Friends. They can live with us forever.

**Suzie's Friends, Inc**  
**C/O EnviroSpec - 751 MLK Hwy**  
**Homerville, GA 31634**

a 501(c)3 Charity  
Your donation is tax deductible.





They come from everywhere to see Suzie's Friends. To the left are a lovely couple (wife driving) who stopped by recently from the Atlanta area on their way to Florida.

Next time you are in the area perhaps you will stop in and see what all the excitement is about.

To the right is the 'treat' shelf. Every day when the dogs are called in for the evening they all get a milk bone.

Below are their air conditioned living quarters.



Every dog gets a bath (like it or not) often. Their nails are trimmed and coats clipped by a professional dog groomer who is paid to come in and 'spiff' up the pack just in case someone stops by looking for a companion. Below is our grooming center.

We hope you have enjoyed the tour of Suzie's Friends Animal Sanctuary.

We love doing what we do for animals and we hope you will help the animals in your community.

Remember, the only chance they have is if we all Spay/Neuter our pets.





# A Tale of Two Pups

a true story by Suzie's Friends

'Jordan'



'Jingles'



## Unlike Jingles...

Jordan had a very sad and lonely life. Shelley Allison caught a glimpse of something moving in the ditch as she & John, her husband, were on the way back to their animal sanctuary in October of 2008. When they turned around there she was with her little tail wagging almost as if she already knew that wonderful things were going to be a part of the rest of her life. It took a lot of love to help her survive.

## Jingles, on the other hand...

found herself living the life that every dog dreams of. Running, playing and, of course, digging holes are just a few of her favorite things that she gets to do everyday. She lives with her adopted family Ken & Kimberly McCord who have made a special place in their hearts and home for this beautiful little girl. Spoiled? Absolutely! Deserving? Absolutely! Why? Her name was once **Jordan**.







## ***DID YOU KNOW***

Each day 10,000 humans are born in the U.S. - and each day 100,000 puppies and kittens are born. As long as these birth rates exist, there will never be enough homes for all the animals.

As a result, millions of healthy, loving cats, dogs, kittens and puppies face early deaths because of what we have grown to believe is our only form of animal control. Others are left to fend for themselves against automobiles, the elements, animals and cruel humans.

I say to you today that warehousing animals in Humane Societies or animal control facilities has absolutely nothing to do with eliminating the problem.

Just recently I read a brochure sent to me from a local animal agency where they talk about their budget as being \$30,000.00 per month and last year they adopted 400 animals. This means that every adoption last year cost \$900.00 each. When you look at the numbers below you can see where spaying 20 female cats means that 6,000 unwanted animals will never show up at an animal shelter or Humane Society.

Here are the facts. An unspayed female cat, her mate and all of their offspring, producing 2 litters per year, with 2.8 surviving kittens per litter can total:

1 Year:	12
2 Years	67
3 Years	376
4 Years	2,107
5 Years	11,801
6 Years	66,088
7 Years	370,092
8 Years	2,072,514
9 Years	11,606,077



*And YES we are still talking about starting out with 1 unspayed cat!*



# EnviroSpec

751 MLK Highway  
Homerville, GA 31634

PRSR STD  
U.S. POSTAGE  
PAID  
PPCO

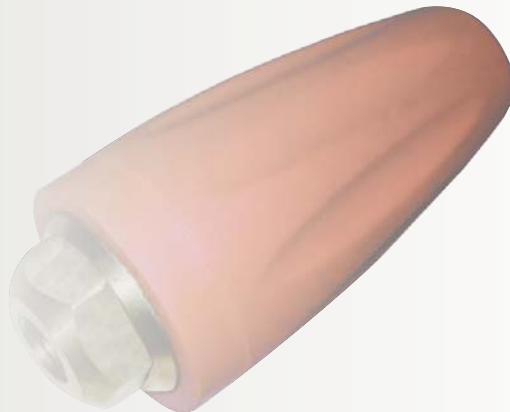

1-800-346-4876

© 2011 EnviroSpec - All Rights Reserved  
Duplication for Personal Use Only